

la calidad
la qualité hablada...
dont on parle...
the spoken
quality...

2021
CATÁLOGO
CATALOGUE



www.akkco.com.tr



Insertos De Corte Y Sistemas De Conexión
Outil de Coupe et System de Connection
Cutting Inserts and Connection Systems

konusulan
the spoken kalite...
quality...









Nosotros somos AKKO Oto. Mak Hird. San Tic. Ltd. Şti, fundada por Abdullah KARAKUŞ en 1986, produce portaherramientas de torneado, portaherramientas de roscado y ranurado, taladros en U, portaherramientas de fresado y portaherramientas de precisión (portaherramientas OEM). Producimos 8000 tipos estándar de portaherramientas con una capacidad de producción de 500,000 piezas por año en un área de aproximadamente 8000 metros cuadrados. Continuamos exportando 75 países, incluidos países europeos, asiáticos, africanos, asiáticos, sudamericanos y de Medio Oriente. Mantenemos listos alrededor de 300,000 piezas de productos producidos en nuestro stock. Las materias primas de acero que fabricamos especialmente para nosotros se entregan en nuestra fábrica y todos los procesos de producción se realizan en nuestra fábrica. Todo el proceso, desde el mecanizado de acero hasta el tratamiento térmico y el recubrimiento de nuestras herramientas, se realiza en nuestra fábrica integrada AKKO.

Nous en tant que AKKO Oto. Mak. Hird. San. Tic. Ltd. Şti, fondée par Abdullah KARAKUŞ en 1986, produisons des porte-outils de tournage, des porte-outils de filetage et de gorges, des forets en U, des porte-outils de fraisage et des porte-outils de précision (porte-outils OEM). Nous fabriquons 8 000 types de porte-outils standard d'une capacité de production de 500 000 pièces par an sur une superficie d'environ 8 000 mètres carrés. Nous exportons actuellement vers 75 pays, dont des pays européens, asiatiques, africains, sud-américains et du Moyen-Orient. Nous gardons environ 300 000 pièces produites dans notre stock. L'acier et les matières premières que nous utilisons sont fabriquées spécialement pour nous et sont livrées à notre usine. Tous les processus de production sont faits dans notre usine. Toutes sortes de processus allant de l'usinage de l'acier au traitement thermique et au revêtement de nos outils sont faits dans notre usine intégrée AKKO.



We as AKKO Oto. Mak. Hird. San. Tic. Ltd. Şti, which has been founded by Abdullah KARAKUŞ in 1986, produce Turning Tool Holders, Threading and Grooving Tool Holders, U-Drills, Milling Tool Holders and Precision Tool Holders (OEM Tool Holders). We produce standard 8000 kinds of tool holders with production capacity of 500.000 pieces per annum in an area about 8000 square meter. We are going on exporting 75 countries including European, Asian, African, South American Countries and Middle East Countries. We keep ready about 300.000 pieces produced products in our stock. Steel Raw materials that we make produced especially for us are delivered our factory and all production process are made in our factory. All kind of process from machining of steel to heat treatment and coating on our tools are made in our integrated factory AKKO.

INSERTOS DE CORTE Y PORTA HERRAMIENTAS	
S11-S14	INSERTOS DE RANURADO POLY-V Y HERRAMIENTAS
S15-S16	INSERTOS Y PORTA HERRAMIENTAS PARA RANURAR RELIEVES Y ESQUINAS
S17-S21	INSERTOS DE BROCHADO Y PORTA HERRAMIENTAS
S22-S25	SET DE INSERTOS DE VALVULA Y PORTAHERRAMIENTA
S26-S29	INSERTOS GIRATORIOS Y PORTA HERRAMIENTAS
PORTA HERRAMIENTAS DE TORNADO EXTERNO	
S33	PORTA HERRAMIENTAS DE TORNADO EXTERNO SISTEMA DE DESIGNACIÓN
S34-S47	PORTA HERRAMIENTAS DE TORNEADO EXTERNO SISTEMA-T
S48-S50	PORTA HERRAMIENTAS DE TORNEADO EXTERNO SISTEMA-M
S51-S62	PORTA HERRAMIENTAS DE TORNEADO EXTERNO SISTEMA-P
S63-S69	PORTA HERRAMIENTAS DE TORNEADO EXTERNO SISTEMA-C
S70-S83	PORTA HERRAMIENTAS DE TORNEADO EXTERNO SISTEMA-S
S83-S87	S-SISTEMA HERRAMIENTAS PARA TORNOS AUTOMÁTICOS CORREDIZO TIPO SUIZO
S87-S90	HERRAMIENTAS SEC
PORTA HERRAMIENTAS DE TORNADO INTERNO	
S92	SISTEMA DE DESIGNACIÓN BARRAS DE MANDRINAR
S93-S98	BARRAS DE MANDRINAR SISTEMA T&C
S99-S103	BARRAS DE MANDRINAR SISTEMA M
S104-S110	BARRAS DE MANDRINAR SISTEMA P
S111-S128	BARRAS DE MANDRINAR SISTEMA S
HERRAMIENTAS ANTIVIBRACIÓN	
S130	SISTEMA DE DESIGNACIÓN DE HERRAMIENTAS ANTIVIBRACIÓN
S131-S136	HERRAMIENTAS ANTIVIBRACIÓN
CARTUCHO	
S138	SISTEMA DE DESIGNACIÓN DE CARTUCHOS
S139-S141	CARTUCHO DE REVISION DE MOTOR TIPO S
S141-S144	CARTUCHO SISTEMA S
S144-S147	SISTEMA P CARTUCHO Y HERRAMIENTAS PARA BISELAR Y CHAMFERAR
PORTA HERRAMIENTAS DE ROSCADO	
S149	SISTEMA DE DESIGNACIÓN HERRAMIENTAS DE ROSCADO
S150-S155	PORTA HERRAMIENTAS DE ROSCADO E INFORMACION TECNICA
INFORMACIÓN TECNICA Y HERRAMIENTAS DE ROSCADO	
S157	SISTEMA DE DESIGNACIÓN HERRAMIENTAS DE RANURADO
S158-S172	PORTA HERRAMIENTAS DE RANURADO EXTERNO
S173-S175	PORTA HERRAMIENTAS DE RANURADO EXTERNO PARA TORNOS AUTOMÁTICOS CORREDIZOS TIPO SUIZO
S177-S179	SOPORTES EXTERIORES PARA HERRAMIENTAS DE RANURADO
S180	SOPORTES EXTERIORES PARA HERRAMIENTAS DE RANURADO TIPO L
S180-S182	CORTADORES PARA TROZADO Y RANURADO PROFUNDO
S182	BLOQUE PARA TROZADO Y CORTADOR DE RANURADO PROFUNDO
S184-S186	PORTA HERRAMIENTAS DE RANURADO EXTERNO CON AGUJERO REFRIGERANTE
S187-S198	HERRAMIENTAS DE RANURADO INTERNO
HERRAMIENTAS DE PERFORACIÓN	
S199-S227	SISTEMA U DRILL Y SISTEMA DE DESIGNACIÓN
S228-S229	BROCAS ANILLOS DE BISELADO Y SISTEMA DE MONTAJE
S230	ADAPTADOR ECCENTRICO PARA TALADROS EN U
S231	FORMATO DE PEDIDO ESPECIAL
S232-S234	HERRAMIENTAS DE CORTE ECONÓMICAS Y SISTEMA DE DESIGNACIÓN
S235-S240	CABEZAS DE MANDRINAR AJUSTABLE Y SISTEMAS DE DESIGNACIÓN
HERRAMIENTAS DE FRESADO	
S242	HERRAMIENTAS DE FRESADO SISTEMA DE DESIGNACIÓN
S243-S244	SISTEMA S DE DESIGNACIÓN MOLINO DE EXTREMO Y BISELADO
S244	HERRAMIENTAS DE FRESADO BISELADO EN HELICE
S245	HERRAMIENTA DE FRESADO DE AISLAMIENTO PARA TORNILLOS CILINDRICOS DE CABEZA ALLEN (DIN 974-1)
S246-S271	SISTEMA S HERRAMIENTA DE FRESADO
S271-S274	S-SISTEMA FRESAS DE CARA Y COPIA
S274-S285	SISTEMA-S FRESADO EXTREMO DE ALTA ALIMENTACIÓN
S285-S295	SISTEMA S DE EXTREMO MODULAR (HERRAMIENTAS DE TORNILLO)
S295-S303	SISTEMA S FRESAS MODULARES DE ALTO AVANCE (TIPO TORNILLO)
S304-S305	FRESAS DE PUNTA DE BOLA
S306-S307	MOLINOS DE EXTREMO MODULAR DE BOLA (TIPO TORNILLO)
S308	PORTA HERRAMIENTAS DE TORNILLO
S308-S309	HERRAMIENTA DE FRESADO ROSCADO
S310	S- SISTEMA FRESADO DE HELIXE EXTREMO
S312-S346	FRESADO FRONTAL
S347-S350	FRONTAL Y COPIA HERRAMIENTAS DE FRESADO
S351-S353	C-SISTEMA PARA FRESADO
S354-S361	HERRAMIENTAS DE FRESADO DE ALTA ALIMENTACIÓN
S362-S363	T FRESADO DE RANURAS
S364-S365	FRESADO DE DISCO
S366-S370	REFERENCIA DE MONTAJE PARA CORTADORAS DE FRESADO e INFORMACIÓN TÉCNICA
RECAMBIOS	
S372-S385	RECAMBIOS
S386-S390	INDICE

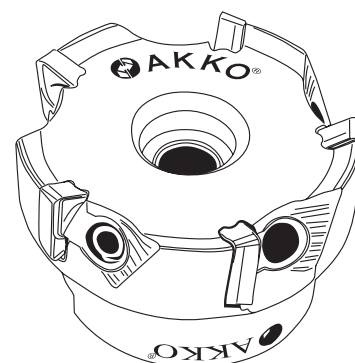
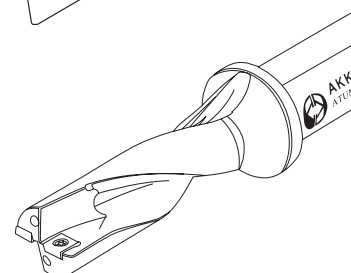
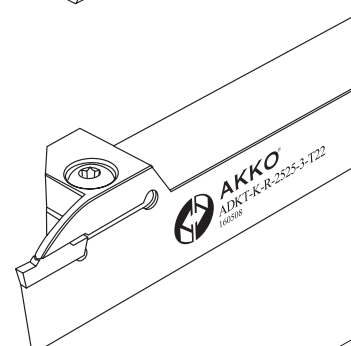
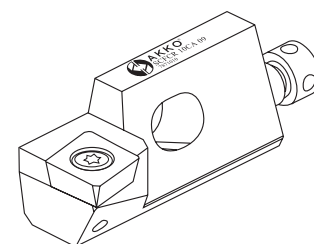
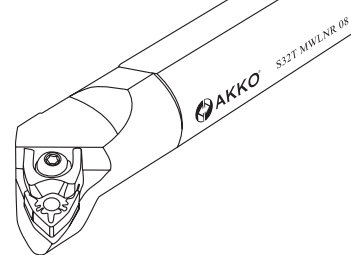
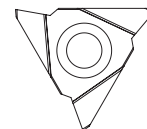

CONTENIDO

TABLE DES MATIÈRES

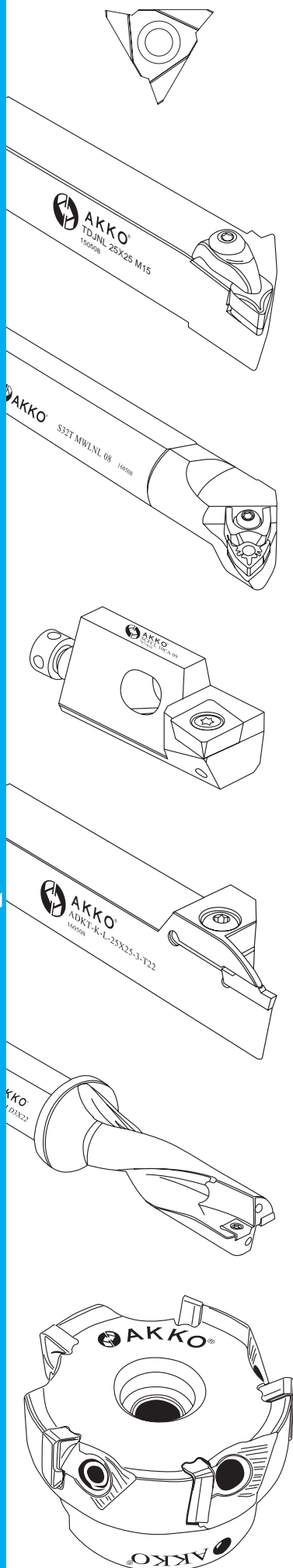

PLAQUETTES DE COUPES ET PORTE-OUTILS

PLAQUETTES POLY-V E GORGES ET PORTE-OUTILS INSERTS et PORTE-OUTILS POUR RAINURER LES RELIEFS D'ANGLE
 PLAQUETTES BROCHEUSES ET PORTE-OUTILS
 PLAQUETTES POUR LES SIÈGES DE SOUPE ET PORTE-OUTILS
 PLAQUETTES POUR TOURBILLONNAGE ET PORTE-OUTILS

P11-P14
 P15-P16
 P17-P21
 P22-P25
 P26-P29

PORTE-OUTILS POUR TOURNAGE EXTERIEUR

SYSTÈME DE DÉSIGNATION DES PORTE-OUTILS DE TOURNAGE EXTERIEUR
 PORTE-OUTILS POUR TOURNAGE EXTERIEUR SYSTÈME-T
 PORTE-OUTILS POUR TOURNAGE EXTERIEUR SYSTÈME-M
 PORTE-OUTILS POUR TOURNAGE EXTERIEUR SYSTÈME-P
 PORTE-OUTILS POUR TOURNAGE EXTERIEUR SYSTÈME-C
 PORTE-OUTILS POUR TOURNAGE EXTERIEUR SYSTÈME-S
 OUTILS DE TYPE-S POUR SYSTÈME SUISSE DES MACHINES COULISSANTE AUTOMATIQUE
 OUTILS SEC

P33
 P34-P47
 P48-P50
 P51-P62
 P63-P69
 P70-P83
 P83-P87
 P87-P90

PORTE-OUTILS DE TOURNAGE INTERIEUR

SYSTÈME DE DÉSIGNATION POUR BARRES DE FORAGE
 BARRES DE D'ALEPAGE SYSTÈME T & C
 BARRES DE D'ALEPAGE SYSTÈME M
 BARRES DE D'ALEPAGE SYSTÈME P
 BARRES DE D'ALEPAGE SYSTÈME S

P92
 P93-P98
 P99-P103
 P104-P110
 P111-P128

OUTILS ANTI VIBRATOIRES

SYSTÈME DE DÉSIGNATION POUR OUTILS ANTI VIBRATOIRES
 OUTILS ANTI VIBRATOIRES

P130
 P131-P136

CARTOUCHE

SYSTÈME DE DÉSIGNATION CARTOUCHE
 CARTOUCHE DE REFORTE DU MOTEUR TYPE-S
 CARTOUCHE SYSTÈME-S
 CARTOUCHES SYSTEM P, BISEAUTAGE ET OUTILS À CHANFREINER

P138
 P139-P141
 P141-P144
 P144-P147

PORTE-OUTILS FILETAGE

SYSTÈME DE DÉSIGNATION POUR PORTE-OUTILS FILETAGE
 PORTE-OUTILS FILETAGE ET INFORMATIONS TECHNIQUES

P149
 P150-P155

PORTE-OUTILS DE RAINURAGE

SYSTÈME DE DÉSIGNATION POUR PORTE-OUTILS DE RAINURAGE
 PORTE-OUTILS DE RAINURAGE EXTERIEUR
 PORTE-OUTILS DE RAINURAGE EXTERIEUR POUR MACHINES DE TYPES SWISS
 PORTE-OUTILS FACE EXTERIEUR A RAINURER
 PORTE-OUTILS FACE EXTERIEUR A RAINURER TYPE-L
 LAMES DE TRANÇONNAGE ET RAINURAGE PROFOND
 BLOCS DE TRANÇONNAGE ET RAINURAGE PROFOND
 PORTE-OUTILS DE RAINURAGE EXTERIEUR AVEC TROU D'ARROSEMENT
 PORTE-OUTILS DE RAINURAGE INTERIEUR

P157
 P158-P172
 P173-P175
 P177-P179
 P180
 P180-P182
 P182
 P184-P186
 P187-P198

OUTILS DE PERÇAGE

FORÊT SYSTÈME-U ET LE SYSTÈME DE DÉSIGNATION
 OUTILS ANNEAUX DE CHANFREINAGE ET SYSTÈME DE MONTAGE
 ADAPTEUR EXCENTRIQUE POUR FORÊT SYSTÈME-U
 FORM DU BON DE COMMANDE DU FORÊT SPÉCIALE
 OUTILS DE COUPE ÉCONOMIQUE ET SYSTÈME DE DÉSIGNATION
 TÊTES D'ALÉSAGE RÉGLABLES ET SYSTÈME DE DÉSIGNATION

P199-P227
 P228-P229
 P230
 P231
 P232-P234
 P235-P240

OUTILS MILLING

SYSTÈME DE DÉSIGNATION DES OUTILS DE FRAISAGE
 FRAISAGE EN BOUT SYSTEM S DE CHANFREINAGE
 FRAISES À CHANFREINER HELIQUE
 FRAISE MILLING OUTIL POUR CYLINDRIQUE ALLEN VIS À TÊTE (DIN 974-1)
 FRAISAGE EN BOUT SYSTEM S
 FRAISAGE EN BOUT SYSTEM S FACIALES ET COPIES
 FRAISAGE EN BOUT SYSTEM S A GRANDE VITESSE
 FRAISAGE EN BOUT MODULAIRE SYSTEM S (OUTILS DE TYPE A VIS)
 SYSTEM S MODULAIRES (TYPE VIS) FRAISE À EXTRÉMITÉ HAUTE AVANCE
 FRAISE À RAINURER
 FRAISE À RAINURER MODULAIRE (TYPE VIS)
 PORTE-OUTILS A VIS
 OUTILS À FILETER
 FRAISE HELIQUE SYSTEM S
 SURFAÇAGE
 OUTILS DE FRAISAGE ET SURFAÇAGE
 FRAISES POUR SYSTÈME C
 OUTILS DE FRAISAGE A GRANDE VITESSE
 RAINURAGE T
 DISQUE À FRAISAGE
 RÉFÉRENCE DE MONTAGE POUR FRAISES DE COUPE ET INFORMATION TECHNIQUE

P242
 P243-P244
 P244
 P245
 P246-P271
 P271-P274
 P274-P285
 P285-P295
 P295-P303
 P304-P305
 P306-P307
 P308
 P308-P309
 P310
 P312-P346
 P347-P350
 P351-P353
 P354-P361
 P362-P363
 P364-P365
 P366-P370

PIÈCES DE RECHANGE

PIÈCES DE RECHANGE
 INDICE

P372-P385
 P386-P390

CUTTING INSERTS and TOOLHOLDERS	
P11-P14	POLY-V GROOVING INSERTS and TOOLHOLDERS
P15-P16	INSERTS and TOOLHOLDERS FOR GROOVING CORNER RELIEFS
P17-P21	BROACHING INSERTS and TOOLHOLDERS
P22-P25	VALVE SEAT INSERTS and TOOLHOLDERS
P26-P29	WHIRLING INSERTS and TOOLHOLDERS
EXTERNAL TURNING TOOLHOLDERS	
P33	EXTERNAL TURNING TOOLHOLDERS DESIGNATION SYSTEM
P34-P47	T-SYSTEM EXTERNAL TURNING TOOLHOLDERS
P48-P50	M-SYSTEM EXTERNAL TURNING TOOLHOLDERS
P51-P62	P-SYSTEM EXTERNAL TURNING TOOLHOLDERS
P63-P69	C-SYSTEM EXTERNAL TURNING TOOLHOLDERS
P70-P83	S-SYSTEM EXTERNAL TURNING TOOLHOLDERS
P83-P87	S-SYSTEM TOOLS FOR SWISS TYPE SLIDING AUTOMATIC LATHES
P87-P90	SEC TOOLS
INTERNAL TURNING TOOLHOLDERS	
P92	BORING BARS DESIGNATION SYSTEM
P93-P98	T&C SYSTEM BORING BARS
P99-P103	M-SYSTEM BORING BARS
P104-P110	P-SYSTEM BORING BARS
P111-P128	S-SYSTEM BORING BARS
ANTIVIBRATION TOOLS	
P130	ANTIVIBRATION TOOL DESIGNATION SYSTEM
P131-P136	ANTIVIBRATION TOOLS
CARTRIDGE	
P138	CARTRIDGE DESIGNATION SYSTEM
P139-P141	S-TYPE ENGINE OVERHAUL CARTRIDGE
P141-P144	S-SYSTEM CARTRIDGE
P144-P147	P-SYSTEM CARTRIDGE AND PIPE BEVELING and CHAMFERING TOOLS
THREADING TOOLHOLDERS	
P149	THREADING TOOLHOLDERS DESIGNATION SYSTEM
P150-P155	THREADING TOOLHOLDERS and TECHNICAL INFORMATION
GROOVING TOOLHOLDERS	
P157	GROOVING TOOLHOLDERS DESIGNATION SYSTEM
P158-P172	EXTERNAL GROOVING TOOLHOLDERS
P173-P175	EXTERNAL GROOVING TOOLHOLDERS FOR SWISS TYPE SLIDING AUTOMATIC LATHES
P177-P179	FACE EXTERNAL GROOVING TOOLHOLDERS
P180	L TYPE FACE EXTERNAL GROOVING TOOLHOLDERS
P180-P182	BLADES FOR PARTING AND DEEP GROOVING
P182	BLOCKS FOR PARTING AND DEEP GROOVING BLADES
P184-P186	EXTERNAL GROOVING TOOLHOLDERS WITH COOLANT TOOLS
P187-P198	INTERNAL GROOVING TOOLHOLDERS
DRILLING and HOLEMAKING TOOLS	
P199-P227	U-DRILL SYSTEM and DESIGNATION SYSTEM
P228-P229	DRILL CHAMFERING RING TOOLS AND MOUNTING SYSTEM
P230	EXCENTRIC ADAPTOR FOR U-DRILLS
P231	SPECIAL DRILL ORDER FORM
P232-P234	ECONOMIC CUTTING TOOLS and DESIGNATION SYSTEM
P235-P240	Adjust Screw BORING HEADS and DESIGNATION SYSTEM
MILLING TOOLS	
P242	MILLING TOOLS DESIGNATION SYSTEM
P243-P244	S-SYSTEM CHAMFERING END MILLS
P244	HELIX CHAMFER MILLING TOOLS
P245	OUTIL DE FRAISAGE POUR VIS À TÊTE ALLEN CYLINDRIQUE (DIN 974-1)
P246-P271	S-SYSTEM END MILLS
P271-P274	S-SYSTEM FACE and COPY END MILLS
P274-P285	S-SYSTEM HIGHFEED END MILLS
P285-P295	S-SYSTEM MODULAR END MILLS (SCREW TYPE TOOLS)
P295-P303	S-SYSTEM MODULAR (SCREW TYPE) HIGHFEED END MILLS
P304-P305	BALL NOSE MILLS
P306-P307	BALL NOSE MODULAR (SCREW TYPE) END MILLS
P308	SCREWED TOOL HOLDERS
P308-P309	THREAD MILLING TOOLS
P310	S-SYSTEM HELIX END MILL
P312-P346	FACE MILLING
P347-P350	FACE and COPY MILLING TOOLS
P351-P353	C-SYSTEM FACE MILLING
P354-P361	HIGH FEED MILLING TOOLS
P362-P363	T SLOT MILLING
P364-P365	DISC MILLING
P366-P370	MOUNTING REFERENCE FOR MILLING CUTTERS and TECHNICAL INFORMATION
SPARE PARTS	
P372-P385	SPARE PARTS
P386-P390	INDEX

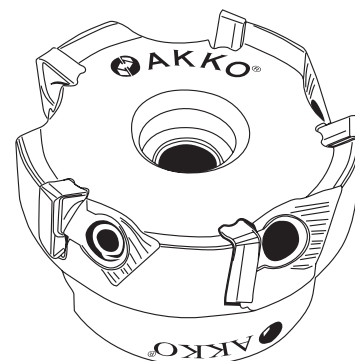
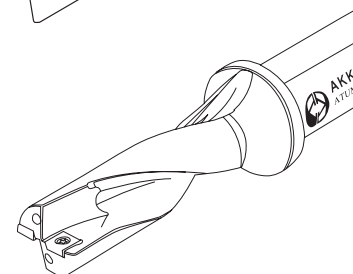
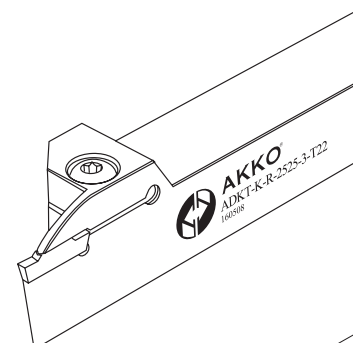
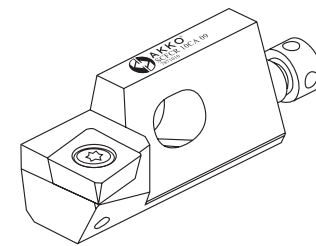
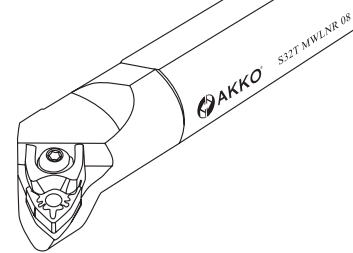
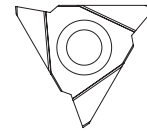

konusulan
the spoken kalite...
quality...





INSERTOS de CORTE Y PORTA HERRAMIENTAS
PLAQUETTES DE COUPES ET PORTE-OUTILS
CUTTING INSERTS and TOOLHOLDERS

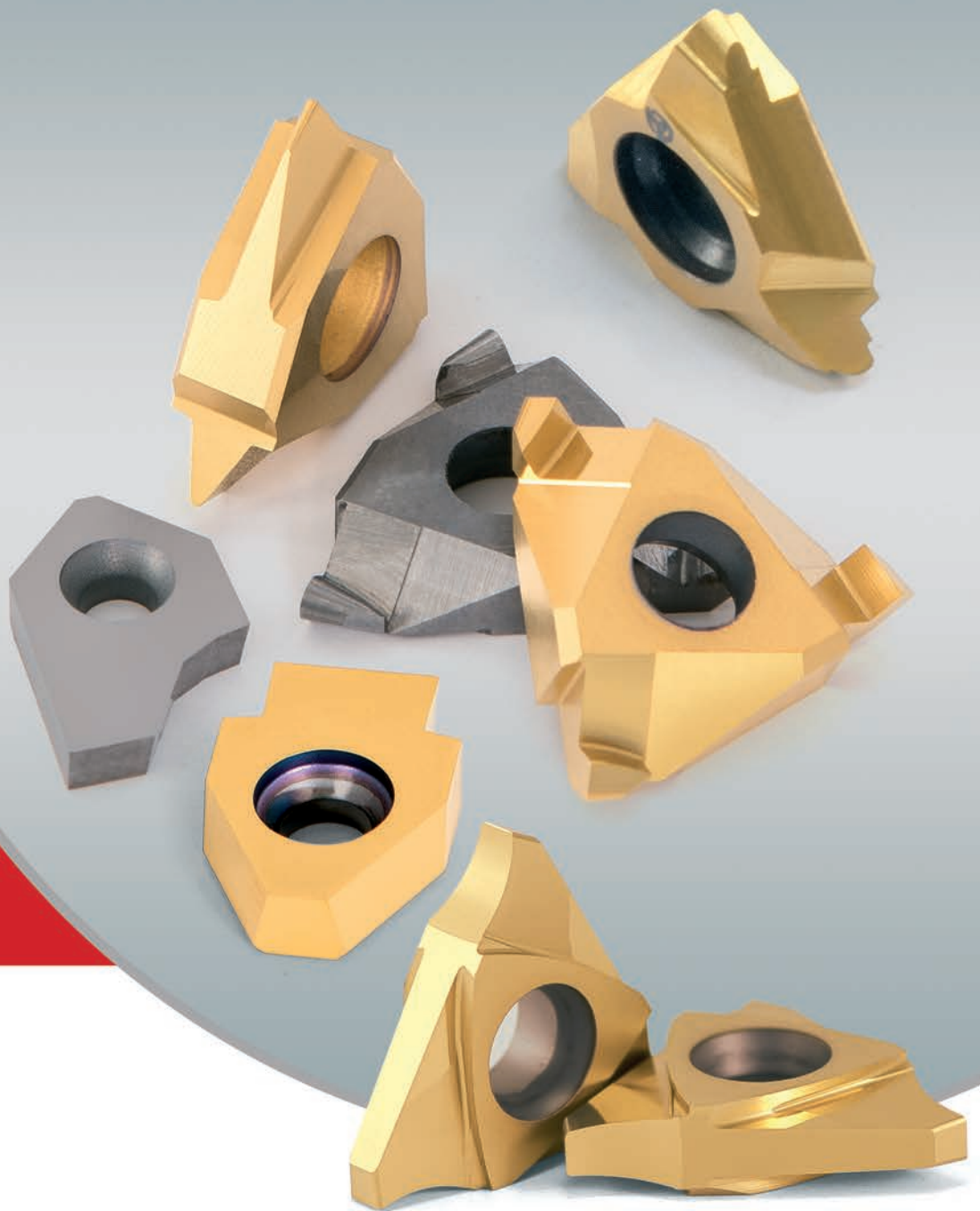

POLY-V

INSERTOS DE RANURADO POLY-V Y HERRAMIENTAS
PLAQUETTES POLY-V E GORGES ET PORTE-OUTILS
POLY-V GROOVING INSERTS and TOOLHOLDERS



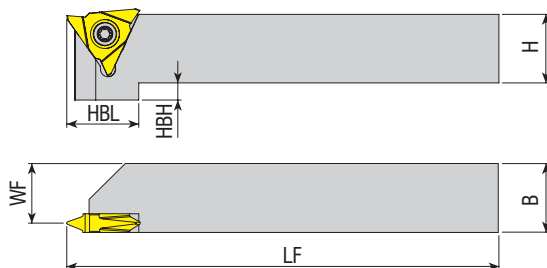

Código del Inserto Le Code de Commande Ordering Code	Stock Stock Stock		Dimension (mm) Dimension (mm) Dimension (mm)					Inserto Plaquette Insert	Recambios / Pièces de Rechange / Spare Parts		
	R	L	H	B	WF	LF	HBL		HBH	Tornillo Vis Screw	Llave Torx Clé Torx Torx Wrench
ADKT-T12P-R/L-1616-T5	●	●	16	16	13.50	125	21	5	 T12...	 1020-M5x14	 80-T20
ADKT-T12P-R/L-2020-T5	●	●	20	20	17.50	125	21	5			
ADKT-T12P-R/L-2525-T5	●	●	25	25	22.50	150	-	-			
ADKT-T12P-R/L-3232-T5	●	●	32	32	29.50	170	-	-			

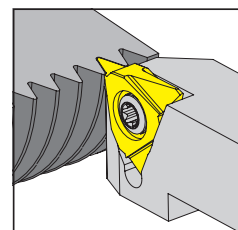
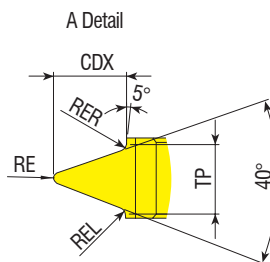
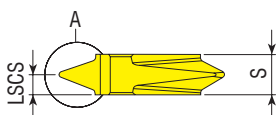
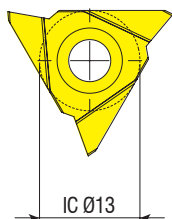

Codigo del Inserto Code de Plaquette Insert Code	Stock Stock Stock		Dimension del Inserto (mm) Dimension de Plaquette (mm) Insert Dimensions (mm)					Grado Nuances Grade	
	R	L	TP	S	RE	RER / REL	LSCS		CDX
T12.10.0234.PJ.R	●	●	2.34	5.20	0.36	0.24	2.60	2.08	VK20F01
T12.10.0356.PK.R	●	●	3.56	5.20	0.44	0.35	2.60	3.40	VK20F01
T12.10.0470.PL.R	●	●	4.70	5.20	0.36	0.45	2.60	4.90	VK20F01

R: Derecha / Droite / Right L: Izquierda / Gauche / Left

● En Existencia / En stock / In Stock ○ Artículo sin Existencia / Indisponible en Stock / Non Stock Item

Ejemplo de Pedido / Exemple de Commande / Ordering Example

1 Piezas / pcs. / pcs. ADKT-T12P-R-1616-T5

Tipo portaherramientas.--Usar con ADKT-T12P... / Utilisation avec ADKT-T12P... Type de porte-outil. / Use with ADKT-T12P... Type Toolholder.

Indexabilidad Longitud ± 0,02 mm / Longueur de l'indexabilité ± 0,02 mm / Indexability length ±0,02mm

Para solicitudes de otras dimensiones, contacte con el representante del cliente. / Pour toute autre demande de dimension, contacter le représentant des ventes

/ For different dimension's requests, please contact our customer representatives.

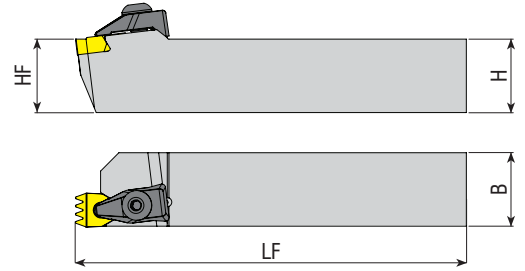

Código del Inserto Le Code de Commande Ordering Code	Stock Stock Stock		Dimension (mm) Dimension (mm) Dimension (mm)			Inserto Plaquette Insert	Recambios / Pièces de Rechange / Spare Parts		
	R	L	HF=H	B	LF		Abrazadera de Cuñas Mode de Fixation Wedge Clamp	Tornillo de Sujeción Vis de Fixation Wedge Screw	Llaves Allen Cles Allen Allen Wrench
ATPVK 2020 K2.34X4	○	○	20	20	125				
ATPVK 2525 M2.34X4	○	○	25	25	150				
ATPVK 3232 P2.34X4	●	○	32	32	170				
ATPVK 2020 K3.56X4	○	○	20	20	125	B26.07.0234PJ.x4	ATK-04	AKV-19-M7X25	AAL-05-4
ATPVK 2525 M3.56X4	○	○	25	25	150				
ATPVK 3232 P3.56X4	●	○	32	32	170				
ATPVK 2020 K4.7X3	○	○	20	20	125	B26.07.0356PK.x4	ATK-04	AKV-19-M7X25	AAL-05-4
ATPVK 2525 M4.7X3	○	○	25	25	150				
ATPVK 3232 P4.7X3	●	○	32	32	170				
						B26.07.0470PL.x3			

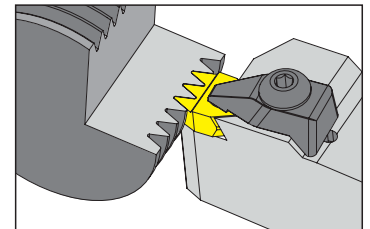
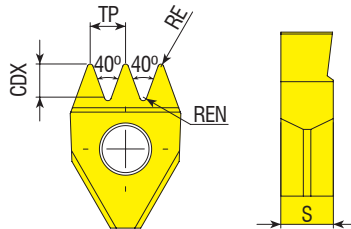

Codigo del Inserto Code de Plaquette Insert Code	Stock Stock Stock	Dimension del Inserto (mm) Dimension de Plaquette (mm) Insert Dimensions (mm)					Grado Nuances Grade
		TP	S	RE	REN	CDX	
B26.07.0234.PJx4	●	2.34	7	0.36	0.24	2.08	VK10F01
B26.07.0356.PKx4	●	3.56	7	0.45	0.35	3.35	VK10F01
B26.07.0470.PLx3	●	4.70	7	0.38	0.45	4.85	VK10F01

R: Derecha / Droite / Right L: Izquierda / Gauche / Left
 ● En Existencia / En stock // In Stock ○ Artículo sin Existencia / Indisponible en Stock / Non Stock Item

Ejemplo de Pedido / Exemple de Commande / Ordering Example
 1 Piezas / pcs. / pcs. ATPVK 2020 K2.34X4

konusulan
the spoken kalite...
quality...



GROOVING

**INSERTOS Y PORTA HERRAMIENTAS PARA RANURAR
RELIEVES Y ESQUINAS**

INSERTS et PORTE-OUTILS POUR RAINURER LES RELIEFS D'ANGLE

INSERTS and TOOLHOLDERS FOR GROOVING CORNER RELIEFS

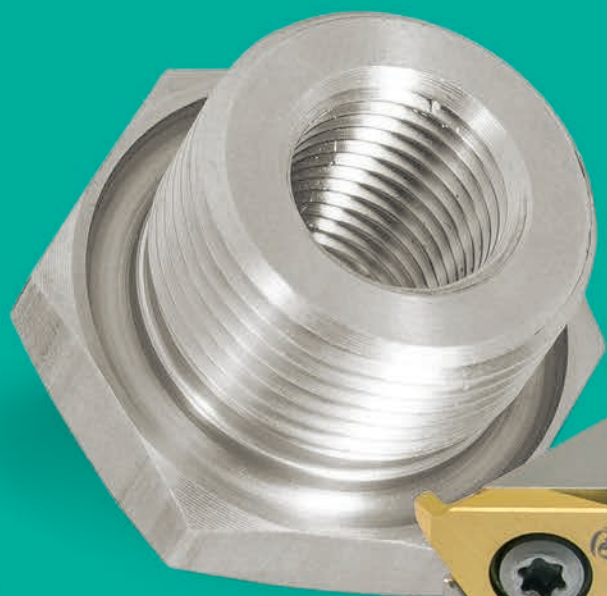

AKKO®
AAUT-T20-R-



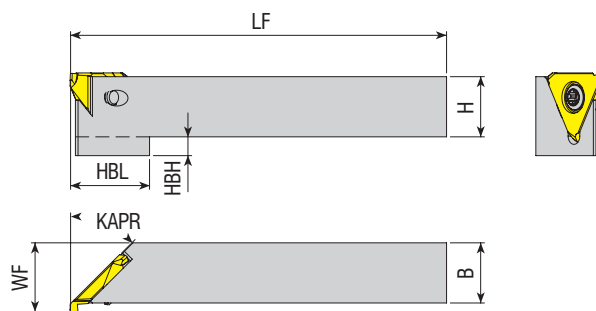

Código del Inserto Le Code de Commande Ordering Code	Stock Stock Stock		Dimension (mm) Dimension (mm) Dimension (mm)							Inserto Plaquette Insert	Recambios / Pièces de Rechange / Spare Parts				
	R	L	H	B	WF	LF	HBL	HBH	KAPR		Tornillo Vis Screw	Llave Torx Clé Torx Torx Wrench			
AAUT-T20-R/L-1616-45	●	●	16	16	18.3	125	21	5	45°						
AAUT-T20-R/L-2020-45	●	●	20	20	22.3	125	21	5	45°				T20...	1020-M5x7.5	80-T20
AAUT-T20-R/L-2525-45	●	●	25	25	27.3	150	-	-	45°						

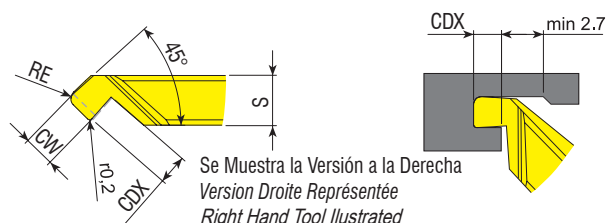
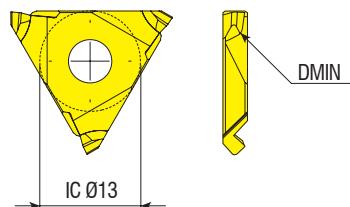

Codigo del Inserto Code de Plaquette Insert Code	Stock Stock Stock		Dimension del Inserto (mm) Dimension de Plaquette (mm) Insert Dimensions (mm)					Grado Nuances Grade	Diametro Minimo Ø Diamètre Minimum Ø Minimum Diameter Ø	Profundidad de Ranura Profondeur de la Rainure Jusqu'à Depth of Groove Up to	Ancho de Ranura Largeur de Rainure Width of Groove
	R	L	CW	S	RE	CDX	DMIN				
T20.00.0815.45.04R/L	●	●	1.5	3.25	0.4	1.6	8	VK20F01	8	1.6	1.5
T20.00.1220.45.05R/L	●	●	2.0	3.25	0.5	1.8	12	VK20F01	12	1.8	2.0
T20.00.2024.45.06R/L	●	●	2.4	3.25	0.6	2.0	20	VK20F01	20	2.0	2.4

Usar con portaherramientas tipo AAUT. / Utilisation avec porte-outil de type AAUT. / To be used with AAUT type tool holder.

El corte debe colocarse antes del mecanizado axial. / La dépouille doit être placée avant l'usinage axial. / The undercut must be placed before axial machining.

Indexabilidad Longitud ± 0,02 mm / Longueur de l'indexabilité ± 0,02 mm / Indexability length ± 0,02mm

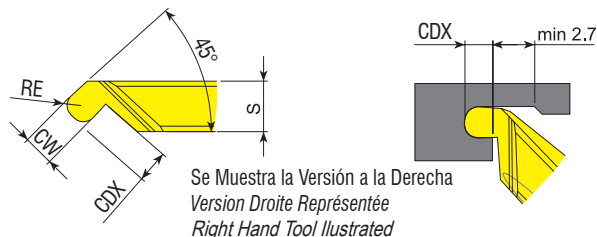
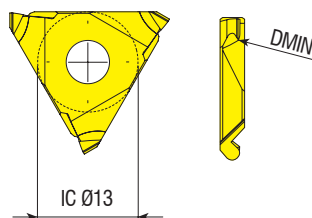

Wendeplatten-Bezeichnung Codice Inserto Insert Code	Lager Magazzino Stock		Abmessung (mm) Dimensione Inserto (mm) Insert Dimension (mm)					Grado Nuances Grade	Kleinsten Durchmesser Ø Diamètre Minimum Ø Minimum Diameter Ø	Stechtiefe Bis Zu Profondeur Di Scandatura Fino a Depth of Groove Up to	Stechbreite Largezza Della Scandatura Width of Groove
	R	L	CW	S	RE	CDX	DMIN				
T20.00.1220.45.10R/L	●	●	2.0	3.25	1.0	1.8	12	VK20F01	12	1.8	2

Usar con portaherramientas tipo AAUT. / Utilisation avec porte-outil de type AAUT. / To be used with AAUT type tool holder.

El corte debe colocarse antes del mecanizado axial. / La dépouille doit être placée avant l'usinage axial. / The undercut must be placed before axial machining.

Indexabilidad Longitud ± 0,02 mm / Longueur de l'indexabilité ± 0,02 mm / Indexability length ± 0,02mm

R: Derecha / Droite / Right L: Izquierda / Gauche / Left

● En Existencia / En stock / In Stock ○ Artículo sin Existencia / Indisponible en Stock / Non Stock Item

Ejemplo de Pedido / Exemple de Commande / Ordering Example

1 Piezas / pcs. / pcs. AAUT-T20-R-1616-45

BROACHING

INSERTOS DE BROCHADO Y PORTA HERRAMIENTAS
PLAQUETTES BROCHEUSES ET PORTE-OUTILS
BROACHING INSERTS and TOOLHOLDERS

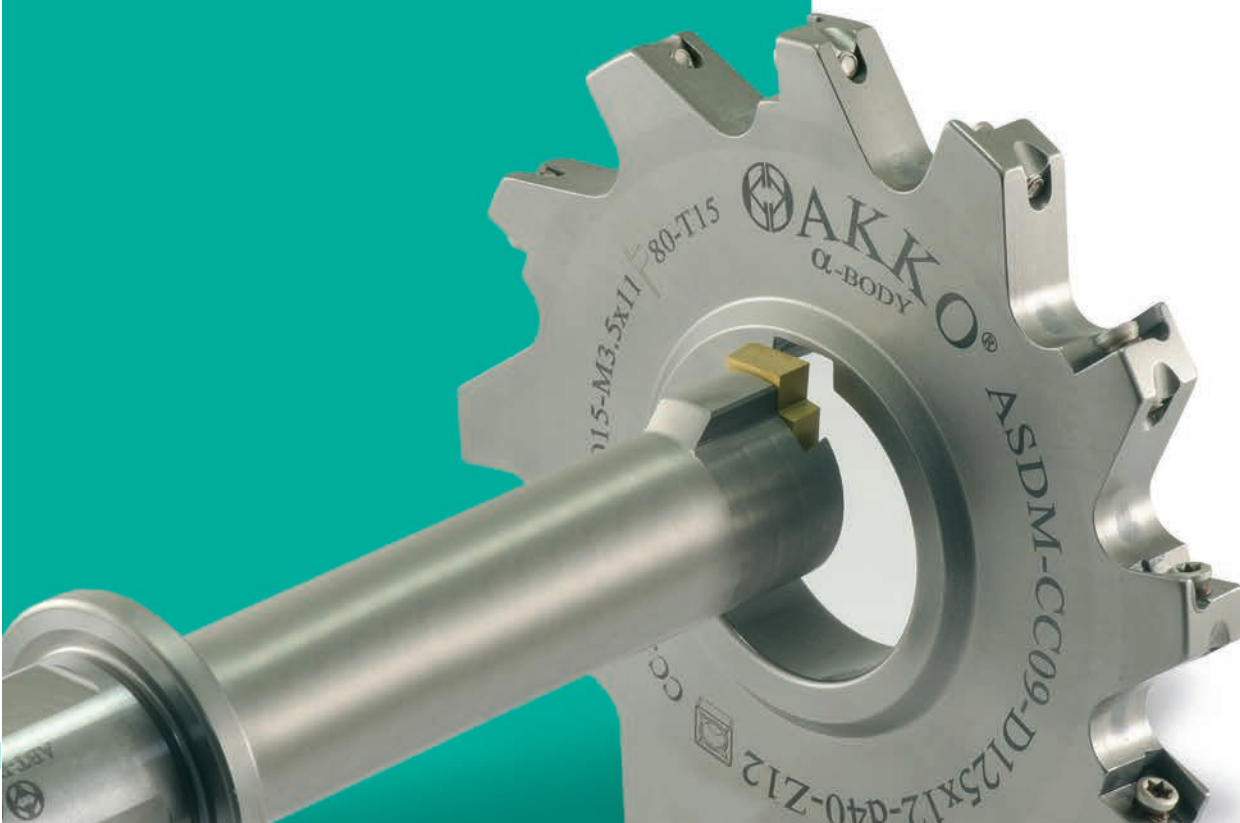

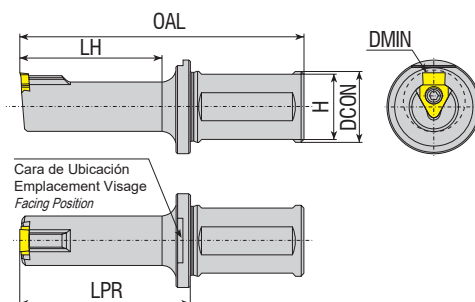

Código del Inserto Le Code de Commande Ordering Code	Stock Stock Stock	Dimension (mm) Dimension (mm) Dimension (mm)						Inserto Plaquette Insert	Recambios / Pièces de Rechange / Spare Parts	
		DMIN	LH	DCON	OAL	LPR	H		Tornillo Vis Screw	Llave Torx Clé Torx Torx Wrench
ABT-B41-D17-Y25-L90-I040	●	17	40	25	90	50	23			
ABT-B41-D17-Y25-L105-I065	●	17	65	25	105	75	23			
ABT-B41-D22-Y25-L100-I050	●	22	50	25	100	60	23			
ABT-B41-D22-Y25-L125-I070	●	22	70	25	125	80	23			
ABT-B42-D30-Y32-L100-I050	●	30	50	32	100	60	30			
ABT-B42-D30-Y32-L125-I075	●	30	75	32	125	85	30			
ABT-B42-D30-Y32-L170-I110	●	30	110	32	170	120	30			
ABT-B42-D38-Y32-L100-I050	●	38	50	32	100	60	30			
ABT-B42-D38-Y32-L125-I075	●	38	75	32	125	85	30			
ABT-B42-D40-Y32-L100-I050	●	40	50	32	100	60	30			
ABT-B42-D40-Y32-L125-I075	●	40	75	32	125	85	30			



Insertos DIN138 (Tolerancia C11) para brochado de chavetero en torno y fresadoras.
 DIN138 (Tolérance C11) pour plaquettes clavetage sur brocher tour et machines de fraisage.
 DIN138 (Tolerance C11) inserts for keyway broaching on lathe and milling machines.

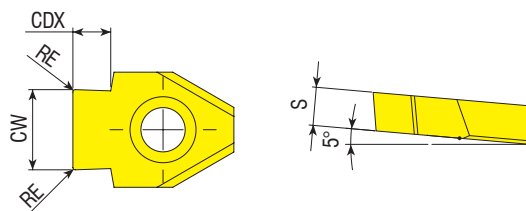

Codigo del Inserto Code de Plaquette Insert Code	Stock Stock Stock	Dimension del Inserto (mm) Dimension de Plaquette (mm) Insert Dimensions (mm)				
		CW	RE	CDX	S	DMIN
B41.00.0612.085.VP3001	●	6.12	0.85	2.6	4.0	22
B41.00.0713.085.VP3001	●	7.13	0.85	3.3	4.0	22
B41.00.0813.105.VP3001	●	8.13	1.05	3.4	4.0	22
B42.00.1013.105.VP3001	●	10.13	1.05	4.2	6.0	30
B42.00.1215.135.VP3001	●	12.15	1.35	5.1	6.0	38
B42.00.1215.175.VP3001	●	12.15	1.75	6.6	6.0	38
B42.00.1215.225.VP3001	●	12.15	2.25	8.5	6.0	38

Condiciones de corte típicas / Conditions de coupe typiques / Typical cutting conditions: Paso (ap): 0.02-0.08 mm / Paso (ap): 0,02 à 0,08 mm / Paso (ap): 0.02-0.08 mm

R: Derecha / Droite / Right L: Izquierda / Gauche / Left

● En Existencia / En stock / In Stock ○ Artículo sin Existencia / Indisponible en Stock / Non Stock Item

Ejemplo de Pedido / Exemple de Commande / Ordering Example

1 Piezas / pcs. / pcs. ABT-B41-D17-Y25-L90-I040

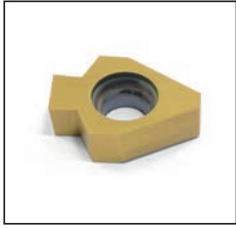

Insertos DIN6885 (Tolerancia P9) para brochado de chavetero en torno y fresadoras.
 DIN6885 (tolerance P9) plaquettes pour brocher clavetage sur tour et machines de fraisage.
 DIN6885 (Tolerance P9) inserts for keyway broaching on lathe and milling machines.

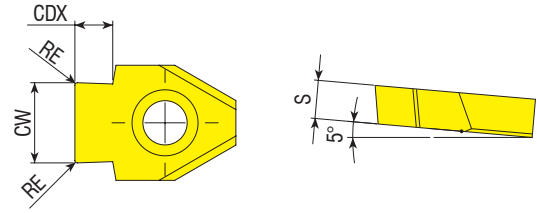

Codigo del Inserto Code de Plaque Insert Code	Stock Stock Stock	Dimension del Inserto (mm) Dimension de Plaque (mm) Insert Dimensions (mm)				
		CW	RE	CDX	S	DMIN
B41.00.0498.020.VP3001	●	4.98	0.20	2.7	4.0	17
B41.00.0598.020.VP3001	●	5.98	0.20	3.4	4.0	17
B41.00.0798.020.VP3001	●	7.98	0.20	4.1	4.0	22
B42.00.0998.030.VP3001	●	9.98	0.30	4.2	6.0	30
B42.00.1197.030.VP3001	●	11.97	0.30	5.7	6.0	38
B42.00.1397.030.VP3001	●	13.97	0.30	6.8	6.0	40

Condiciones de corte típicas / Conditions de coupe typiques / Typical cutting conditions: Paso (ap): 0.02-0.08 mm / Paso (ap): 0,02 à 0,08 mm / Paso (ap): 0.02-0.08 mm



Insertos DIN6885 (Tolerancia JS9) para brochado de chavetero en torno y fresadoras.
 DIN6885 plaquettes (tolerance JS9) pour brocher clavetage sur tour et machines de fraisage.
 DIN6885 (Tolerance JS9) inserts for keyway broaching on lathe and milling machines.

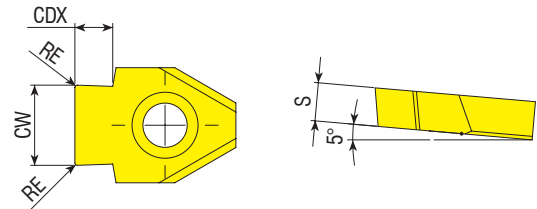

Codigo del Inserto Code de Plaque Insert Code	Stock Stock Stock	Dimension del Inserto (mm) Dimension de Plaque (mm) Insert Dimensions (mm)				
		CW	RE	CDX	S	DMIN
B41.00.0501.020.VP3001	●	5.01	0.20	2.7	4.0	17
B41.00.0601.020.VP3001	●	6.01	0.20	3.4	4.0	17
B41.00.0801.020.VP3001	●	8.01	0.20	4.1	4.0	22
B42.00.1001.030.VP3001	●	10.01	0.30	4.2	6.0	30
B42.00.1200.050.VP3001	●	12.00	0.50	8.5	6.0	38
B42.00.1201.030.VP3001	●	12.01	0.30	5.7	6.0	38
B42.00.1401.030.VP3001	●	14.01	0.30	6.8	6.0	40

Condiciones de corte típicas / Conditions de coupe typiques / Typical cutting conditions: Paso (ap): 0.02-0.08 mm / Paso (ap): 0,02 à 0,08 mm / Paso (ap): 0.02-0.08 mm

R: Derecha / Droite / Right L: Izquierda / Gauche / Left

Ejemplo de Pedido / Exemple de Commande / Ordering Example

● En Existencia / En stock / In Stock ○ Artículo sin Existencia / Indisponible en Stock / Non Stock Item

1 Piezas / pcs. / pcs. B41.00.0498.020.VP3001

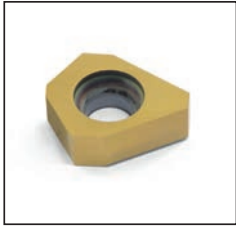

Insertos para chaflán de chavetero en torno y fresadoras.
Les plaquetteions pour les chanfreins clavetage sur tour et machines de fraisage.
 Inserts for keyway chamfering on lathe and milling machines.

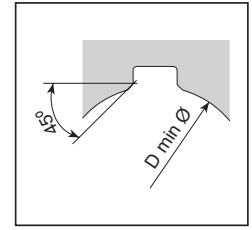
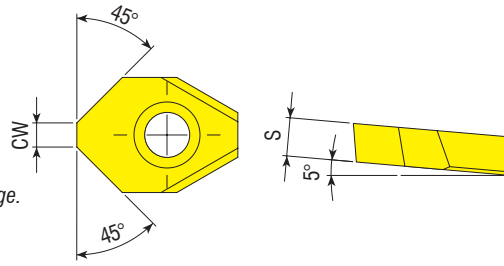

Codigo del Inserto <i>Code de Plaquette</i> <i>Insert Code</i>	Stock <i>Stock</i> <i>Stock</i>	Dimension del Inserto (mm) <i>Dimension de Plaquette (mm)</i> <i>Insert Dimensions (mm)</i>		
		DMIN	CW	S
B41.00.0150.CH.VP3001	●	17	1.5	4.0
B41.00.0300.CH.VP3001	●	22	3.0	4.0
B42.00.0600.CH.VP3001	●	30	6.0	6.0

Condiciones de corte típicas / *Conditions de coupe typiques* / *Typical cutting conditions*: Paso (ap): 0.02-0.08 mm / Paso (ap): 0,02 à 0,08 mm / Paso (ap): 0.02-0.08 mm

R: Derecha / *Droite* / *Right* L: Izquierda / *Gauche* / *Left*

Ejemplo de Pedido / *Exemple de Commande* / *Ordering Example*

● En Existencia / *En stock* / *In Stock* ○ Artículo sin Existencia / *Indisponible en Stock* / *Non Stock Item*

1 Piezas / *pcs.* / *pcs.* B41.00.0150.CH.VP3001

INSERTOS PERFILADOS / PROFILE DES PLAQUETTES / PROFILED INSERTS
EJEMPLOS DE PERFILES / EXEMPLES DE PROFILS / EXAMPLES OF PROFILES

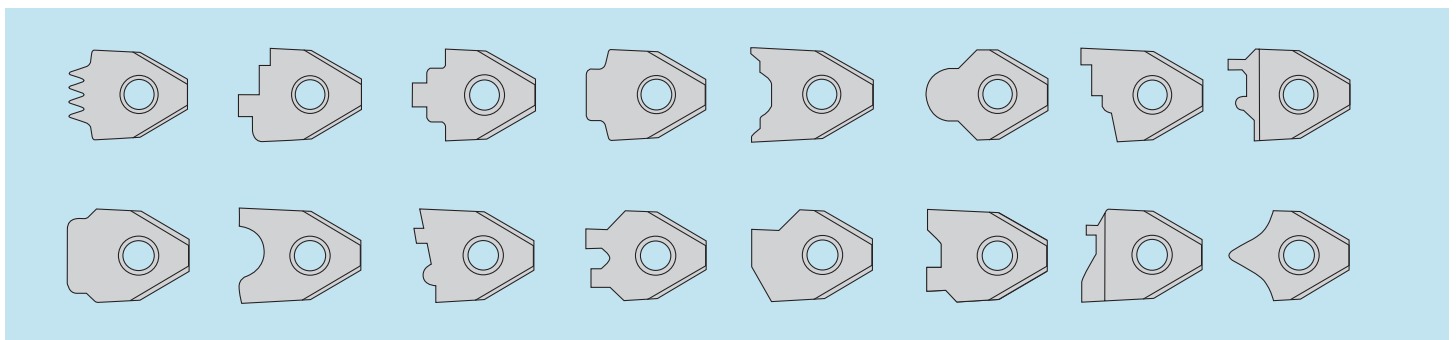

Los insertos perfilados se fabrican de acuerdo con los requisitos especiales del cliente.
Plaquettes profilés sont fabriqués selon les exigences particulières de la clientèle.
Profiled inserts are manufactured according to customer special requirements.

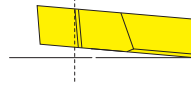
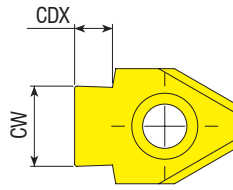
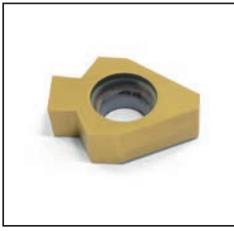

Ancho de Ranura Largeur de Rainure Width of Groove	Tolerancia Tolérance Tolerance	Tamaño del Inserto (mm) Taille de Plaquette (mm) Insert Size (mm)	W	t max	Inserto Plaquettes Inserts	Dmin Aplicable Para Portaherramientas e Insertos de Mesa Dmin Applicable Pour Table et Porte-Outils Plaquettes Dmin Table For Applicable Inserts and Tool Holders				
						ABT-B41-D17...	ABT-B41-D22...	ABT-B42-D30...	ABT-B42-D38...	ABT-B42-D40...
6	C11	6	6.12	2.6	B41.00.0612.085.VP3001		22	X	X	X
7		7	7.13	3.3	B41.00.0713.085.VP3001		22	X	X	X
8		8	8.13	3.4	B41.00.0813.105.VP3001		22	X	X	X
10		10	10.13	4.2	B42.00.1013.105.VP3001	X	X	30	X	X
12		12		5.1	B42.00.1215.135.VP3001	X	X	X	38	
16		12	12.15	6.6	B42.00.1215.175.VP3001	X	X	X	38	
24		12		8.5	B42.00.1215.225.VP3001	X	X	X	38	
5	P9	5	4.98	2.7	B41.00.0498.020.VP3001	17		X	X	X
6		6	5.98	3.4	B41.00.0598.020.VP3001	17		X	X	X
8		8	7.98	4.1	B41.00.0798.020.VP3001		22	X	X	X
10		10	9.98	4.2	B42.00.0998.030.VP3001	X	X	30		
12		12	11.97	5.7	B42.00.1197.030.VP3001	X	X		38	
14		14	13.97	6.8	B42.00.1397.030.VP3001	X	X			40
5	JS9	5	5.01	2.7	B41.00.0501.020.VP3001	17		X	X	X
6		6	6.01	3.4	B41.00.0601.020.VP3001	17		X	X	X
8		8	8.01	4.1	B41.00.0801.020.VP3001		22	X	X	X
10		10	10.01	4.2	B42.00.1001.030.VP3001	X	X	30		
12		12	12.00	8.5	B42.00.1200.050.VP3001	X	X		38	
12		12	12.01	5.7	B42.00.1201.030.VP3001	X	X		38	
14		14	14.01	6.8	B42.00.1401.030.VP3001	X	X			40

FORMULARIO DE INFORMACIÓN DE INSERTOS DE BROCHADO

BROCHEUSES PLAQUETTE FORMULAIRE D'INFORMATION
 BROACHING INSERT INFORMATION FORM

Dimensión del Agujero / Dimension de l'alésage / Dimension of Bore

b			
t			
r			
d/min*			
Material de Trabajo Matériel de Travail Work Material			
Grupo de Tolerancia / Groupe de Tolérance / Tolerance Group			
C11	P9		JS9

VALVE SEAT

SET DE INSERTOS DE VALVULA Y PORTAHERRAMIENTA
PLAQUETTES POUR LES SIÈGES DE SOUPAPE ET PORTE-OUTILS
VALVE SEAT INSERTS and TOOLHOLDERS



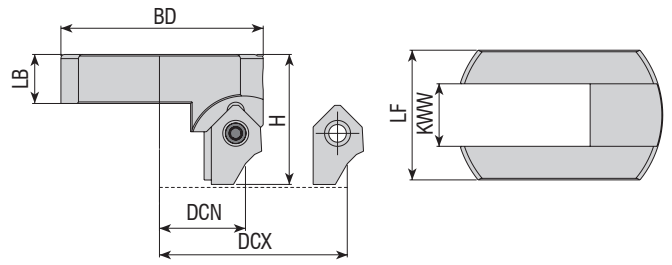

Código del Inserto Le Code de Commande Ordering Code	Stock Stock Stock	Dimension (mm) Dimension (mm) Dimension (mm)						Inserto Plaquette Insert	Recambios / Pièces de Rechange / Spare Parts				
		DCN DCX	BD	LB	H	KWW	LF		Tornillo Vis Screw	Llave Torx Clé Torx Torx Wrench	Ajustable Adjustable Adjust Screw	Llaves Allen Clés Allen Allen Wrench	
VST-B11-2842	●	28-42	29	9.5	28.5	12	25.0		3008-M3x8	80-T08	2702-M4x10	AAL-01-02	
VST-B11-4058	●	40-58	39	9.5	25.0	12	25.0	B11...					

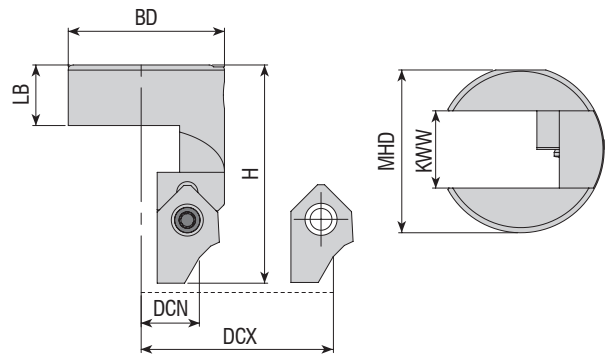

Código del Inserto Le Code de Commande Ordering Code	Stock Stock Stock	Dimension (mm) Dimension (mm) Dimension (mm)						Inserto Plaquette Insert	Recambios / Pièces de Rechange / Spare Parts				
		DCN DCX	BD	LB	H	KWW	MHD		Tornillo Vis Screw	Llave Torx Clé Torx Torx Wrench	Ajustable Adjustable Adjust Screw	Llaves Allen Clés Allen Allen Wrench	
VST-B11-1830	●	18-30	24	9.5	34.0	12	25.3		3008-M3x8	80-T08	2702-M4x10	AAL-01-02	

R: Derecha / Droite / Right L: Izquierda / Gauche / Left

● En Existencia / En stock / In Stock ○ Artículo sin Existencia / Indisponible en Stock / Non Stock Item

Ejemplo de Pedido / Exemple de Commande / Ordering Example

1 Piezas / pcs. / pcs. VST-B11-2842

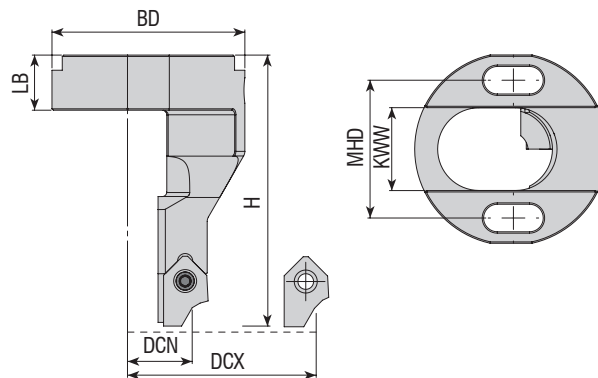

Código del Inserto Le Code de Commande Ordering Code	Stock Stock Stock	Dimension (mm) Dimension (mm) Dimension (mm)						Inserto Plaquette Insert	Recambios / Pièces de Rechange / Spare Parts				
		DCN DCX	BD	LB	H	KWW	MHD		Tornillo Vis Screw	Llave Torx Cle Torx Torx Wrench	Ajustable Adjustable Adjust Screw	Llaves Allen Cles Allen Allen Wrench	
VST-B11-2032	●	20-32	42	12	59	18	30	B11...					
VST-B11-2434	●	24-34	26	14	40	11	18.1						3008-M3x8

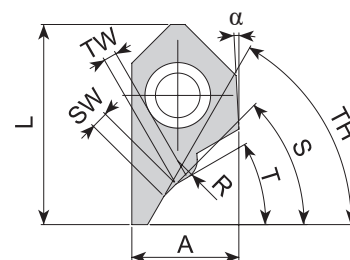
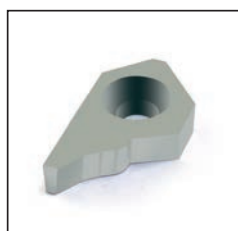

Codigo del Inserto Code de Plaquette Insert Code	Stock Stock Stock	Dimension del Inserto (mm) Dimension de Plaquette (mm) Insert Dimensions (mm)								
		S°	SW	T°	TW	TH°	A	L	α	R
B11013	●	45°	1.3	30°	1	60°	8.15	15.10	3°	1.50

R: Derecha / Droite / Right L: Izquierda / Gauche / Left
 ● En Existencia / En stock / In Stock ○ Artículo sin Existencia / Indisponible en Stock / Non Stock Item

Ejemplo de Pedido / Exemple de Commande / Ordering Example
 1 Piezas / pcs. / pcs.VST-B11-2032



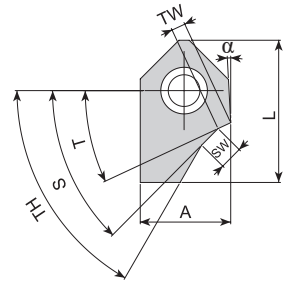
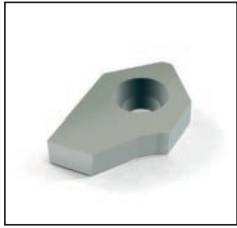

Codigo del Inserto Code de Plaquette Insert Code	Stock Stock Stock	Dimension del Inserto (mm) Dimension de Plaquette (mm) Insert Dimensions (mm)							
		S°	SW	T°	TW	TH°	A	L	α
B11003	●	45°	1.3	25°	1.1	52°	9.7	15.25	3°
B11004	●	45°	1.6	25°	1.3	52°	9.7	15.25	3°
B11005	●	45°	2	25°	1.3	52°	9.7	15.25	3°
B11006	●	45°	2.5	25°	1.5	52°	9.7	15.25	3°
B11007	●	45°	1.5	30°	1.5	60°	9.7	15.25	3°
B11008	●	45°	1.3	25°	1.1	60°	9.7	15.25	3°
B11009	●	45°	1.6	25°	1.3	60°	9.7	15.25	3°
B11010	●	45°	2	25°	1.3	60°	9.7	15.25	3°
B11011	●	30°	2	15°	1.8	60°	9.7	15.25	3°
B11012	●	36°	2	15°	1.6	60°	9.7	15.25	3°
B11014	●	45°	2.5	25°	1.5	60°	9.7	15.25	3°
B11016	●	30°	1.5	15°	1.3	60°	9.7	15.25	3°
B11017	●	30°	2.5	15°	1.8	60°	9.7	15.25	3°
B11018	●	36°	2.5	15°	1.6	60°	9.7	15.25	3°
B11019	●	20°	2.5	10°	2	75°	9.7	15.25	3°
B11020	●	45°	1.3	25°	1.1	52°	7.7	15.25	3°
B11021	●	30°	3	15°	1.8	60°	9.7	15.25	3°
B11022	●	45°	3	30°	1.8	60°	9.7	15.25	3°
B11029	●	40°	2.5	25°	1.5	60°	9.7	15.25	3°
B11030	●	20°	2	10°	1.3	60°	9.7	15.25	3°
B11031	●	45°	1.8	30°	1.3	60°	9.7	15.25	3°
B11032	●	45°	1.5	30°	1	52°	9.7	15.25	3°
B11033	●	45°	2	30°	1.1	52°	9.7	15.25	3°
B11034	●	45°	2.5	30°	1.3	52°	9.7	15.25	3°
B11035	●	30°	1.5	15°	1	45°	9.7	15.25	3°
B11036	●	30°	2	15°	1.1	45°	9.7	15.25	3°
B11037	●	30°	2.5	15°	1.3	45°	9.7	15.25	3°

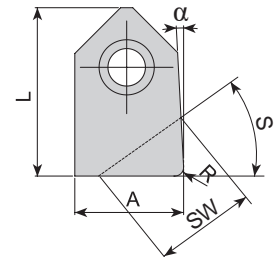

Codigo del Inserto Code de Plaquette Insert Code	Stock Stock Stock	Dimension del Inserto (mm) Dimension de Plaquette (mm) Insert Dimensions (mm)					
		S°	SW	A	L	α	R
B11015	●	0°	9.85	9.85	15.10	3°	0.80
B11023	●	0°	7.7	7.7	15.10	3°	0.80
B11024	●	20°	8.2	9.75	15.10	3°	-
B11025	●	25°	10	9.65	15.10	3°	-
B11026	●	30°	9	9.65	15.10	3°	-
B11027	●	35°	10	9.60	15.10	3°	-
B11028	●	45°	8.9	9.55	15.10	3°	-

R: Derecha / Droite / Right L: Izquierda / Gauche / Left

● En Existencia / En stock / In Stock ○ Artículo sin Existencia / Indisponible en Stock / Non Stock Item

Ejemplo de Pedido / Exemple de Commande / Ordering Example

1 Piezas / pcs. / pcs.B11003

WHIRLING

INSERTOS GIRATORIOS Y PORTA HERRAMIENTAS
PLAQUETTES POUR TOURBILLONNAGE ET PORTE-OUTILS
WHIRLING INSERTS and TOOLHOLDERS

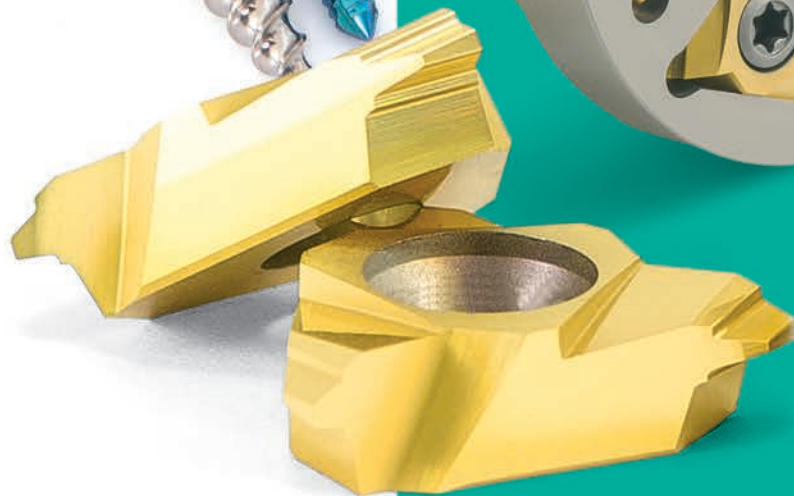

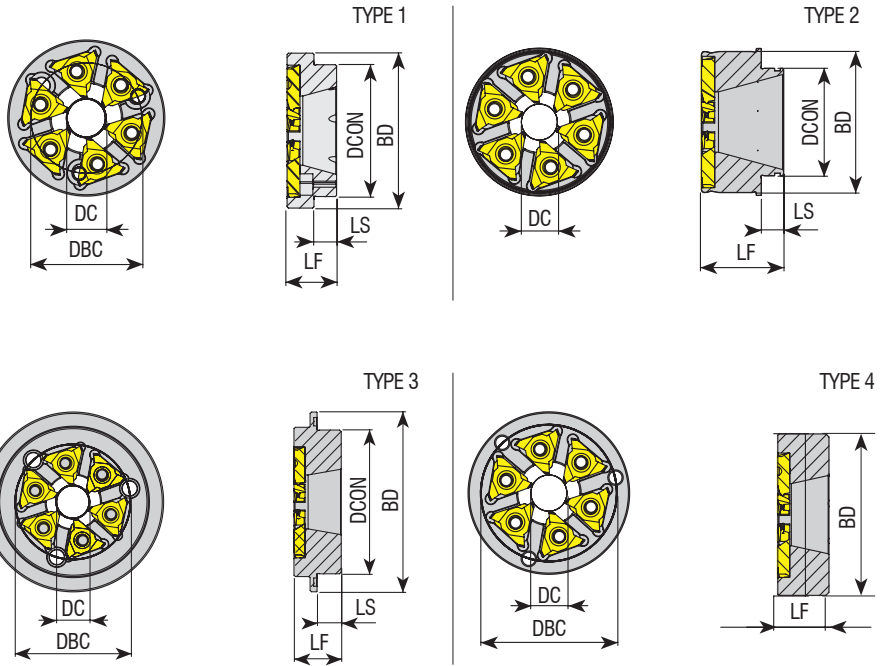

Máquina Machine Machine	Unidad de Giro Agregada Unité D'agitation Tourbillonnante Driven Whirling Unit	Código de Anillo Giratorio Code de Bague Tourbillonnant Whirling Ring Code	Stock Stock Stock	Dimension (mm) Dimension (mm) Dimension (mm)								Inserto Plaquette Insert	Recambios / Pièces de Rechange / Spare Parts	
				ZEPF	DC	DCON	DBC	BD	LS	LF	Tornillo Vis Screw		Llave Torx Clé Torx Torx Wrench	
STAR	5914 72 00/68172	ATW-301-T09-D1240-Z06	●	6	12	40	33	47	7	15	1			
CITIZEN	BTW1000	ATW-302-T09-D1233-Z06	○	6	12	33	40	47	4	18.5	-			
	GSW101	ATW-303-T09-D0620-Z06	○	6	6	20	26	35	3.2	15	1			
	MWS101/KSW101	ATW-304-T09-D1240-Z06	○	6	12	40	32.5	46	2.5	15.5	1			
	LSW101/BSW215/ LSW215315		○	6	12	40	32.5	46	2.5	15.5	1			
	LSW424		ATW-305-T09-D1245-Z06	○	6	12	45	30	46	9.5	18			
TORNOS	306101/307087	ATW-306-T09-D1240-Z06	●	6	12	40	31	57	3.5	15	-			
	417617	ATW-307-T09-D1250-Z06	○	6	12	50	40	67	3.5	15.4	-			
WTO	TN762004	ATW-308-T09-D1142-Z06	●	6	11	31.97	-	42	6.7	24.7	2			
	TN762006	ATW-309-T09-D2054-Z08	○	8	20	56.5	-	54	1.5	13.8	2			
TSUGAMI	3234 Y342	ATW-310-T09-D1252-Z06	●	6	12	52	42	65	8.7	17	3			
	3268 Y452	ATW-311-T09-D1252-Z06	○	6	12	52	44	52	10	10	3			
	3268 Y271	ATW-312-T09-D1252-Z06	○	6	12	52	38	54	6	19	3			
	3214 Y342	ATW-313-T09-D1650-Z06	○	6	16	50	40	62	8.5	20	3			
	3234 Y342	ATW-314-T09-D2052-Z06	○	6	20	52	42	65	8.7	17	3			
	3281-Y451	ATW-316-T09-D1252-Z06	●	6	12	52	44	52	-	17	4			
HANWHA	MADAULA	ATW-315-T09-D1245-Z06	○	6	12	45	-	56	8.5	15	1			

R: Derecha / Droite / Right L: Izquierda / Gauche / Left

● En Existencia / En stock / In Stock ○ Artículo sin Existencia / Indisponible en Stock / Non Stock Item

Ejemplo de Pedido / Exemple de Commande / Ordering Example

1 Piezas / pcs. / pcs. ATW-301-T09-D1240-Z06

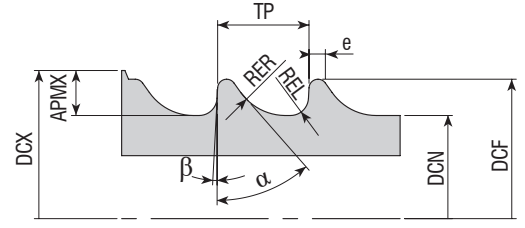
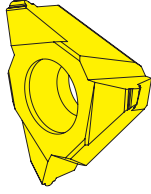
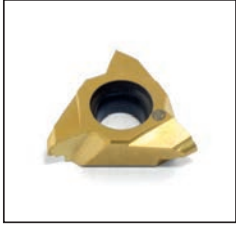

Codigo del Inserto Code de Plaquette Insert Code	Grado Nuances Grade		Standart ISO5835	Dimension del Inserto (mm) Dimension de Plaquette (mm) Insert Dimensions (mm)									
	VK15U	VK15U01		TP	e	DCF	DCN	RER	REL	α	β	APMX	DCX
				T09.HA150.D12	●	●	HA1.5	0.5	0.1	1.35 to 1.5	1.0 to 1.1	0.30	0.1
T09.HA200.D12	●	●	HA2.0	0.6	0.1	1.85 to 2.0	1.2 to 1.3	0.40	0.1	35°	3°	4	9
T09.HA270.D12	●	●	HA2.7	1	0.1	2.55 to 2.7	1.75 to 1.9	0.60	0.2	35°	3°	4	9.5
T09.HA350.D12	●	●	HA3.5	1.25	0.1	3.35 to 3.5	2.25 to 2.4	0.80	0.2	35°	3°	4	10
T09.HA400.D12	●	●	HA4.0	1.5	0.1	3.85 to 4.0	2.75 to 2.9	0.80	0.2	35°	3°	4	10.5
T09.HA450.D12	●	●	HA4.5	1.75	0.1	4.35 to 4.5	2.85 to 3.0	1.00	0.3	35°	3°	4	11
T09.HA500.D12	●	●	HA5.0	1.75	0.1	4.85 to 5.0	3.35 to 3.5	1.00	0.3	35°	3°	4	11
T09.HB400.D12	●	●	HB4.0	1.75	0.1	3.85 to 4.0	1.75 to 1.9	0.80	0.3	25°	5°	4	9.5
T09.HB650.D12	●	●	HB6.5	2.75	0.2	6.35 to 6.5	2.85 to 3.0	1.20	0.8	25°	5°	4	11

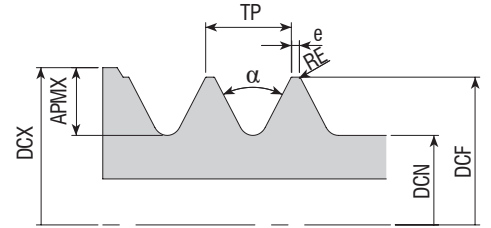
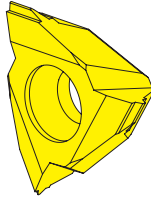
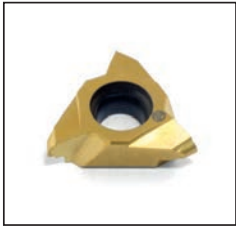

Codigo del Inserto Code de Plaquette Insert Code	Grado Nuances Grade		Standart ISO9268	Dimension del Inserto (mm) Dimension de Plaquette (mm) Insert Dimensions (mm)							
	VK15U	VK15U01		TP	e	DCF	DCN	α	RE	APMX	DCX
				T09.HC290.D12	○	○	HC2.9	1.06	0.1	2.79 to 2.90	2.03 to 2.18
T09.HC350.D12	○	○	HC3.5	1.27	0.1	3.43 to 3.53	2.51 to 2.64	60°	0.01	4	11
T09.HC390.D12	○	○	HC3.9	1.27	0.1	3.78 to 3.91	2.77 to 2.92	60°	0.01	4	11.5
T09.HC420.D12	○	○	HC4.2	1.27	0.1	4.09 to 4.22	2.95 to 3.25	60°	0.01	4	12

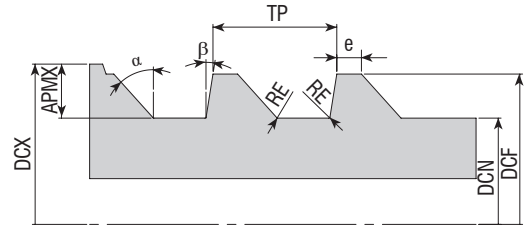
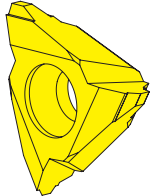
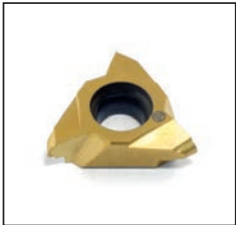

Codigo del Inserto Code de Plaquette Insert Code	Grado Nuances Grade		Standart ISO9268	Dimension del Inserto (mm) Dimension de Plaquette (mm) Insert Dimensions (mm)								
	VK15U	VK15U01		TP	e	DCF	DCN	RE	α	β	APMX	DCX
				T09.HD400.D12	○	○	HD4.0	1.59	0.1	3.97 to 4.03	2.89 to 2.95	0.01
T09.HD450.D12	○	○	HD4.5	2.18	0.1	4.47 to 4.53	2.89 to 2.95	0.01	45°	10°	4	12

R: Derecha / Droite / Right L: Izquierda / Gauche / Left
 ● En Existencia / En stock / In Stock ○ Artículo sin Existencia / Indisponible en Stock / Non Stock Item

Ejemplo de Pedido / Exemple de Commande / Ordering Example
 1 Piezas / pcs. / pcs. T09.HA150.D12

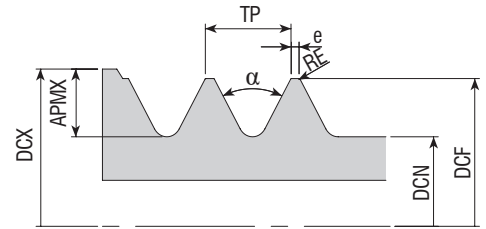
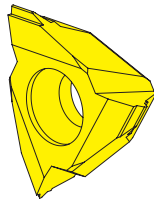
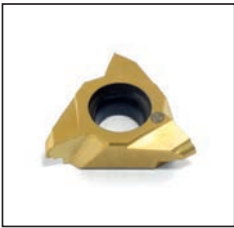

Codigo del Inserto Code de Plaquette Insert Code	Grado Nuances Grade		Standart DIN13	Dimension del Inserto (mm) Dimension de Plaquette (mm) Insert Dimensions (mm)						
	VK15U	VK15U01		TP	DCF	DCN	a	RE	APMX	DCX
T09.M200.D12	●	●	M2	0.4	2	1.509	60	0.048	4	9
T09.M250.D12	●	●	M2.5	0.45	2.5	1.928	60	0.055	4	9.5
T09.M300.D12	●	●	M3	0.5	3	2.387	60	0.062	4	10
T09.M350.D12	●	●	M3.5	0.6	3.5	2.744	60	0.077	4	8.5
T09.M400.D12	●	●	M4.0	0.7	4	3.141	60	0.091	4	11
T09.M500.D12	●	●	M5.0	0.8	5	4.019	60	0.105	4	11.5
T09.M600.D12	●	●	M6.0	1	6	4.773	60	0.134	4	12.5
T09.M700.D12	●	●	M7.0	1	7	5.753	60	0.134	4	13.5
T09.M800.D12	●	●	M8.0	1.25	8	6.446	60	0.17	4	14

Posición de Inicio de Corte
 Position de Départ de Coupe
 Cutting Start Position

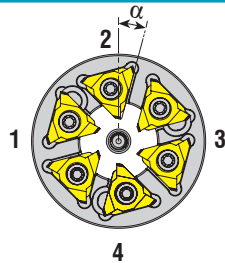

Eje Y
 Axe Y
 Y Axis

Dirección de Giro de la Pieza de Trabajo
 Sens de Rotation de la Pièce
 Turning Direction of Workpiece

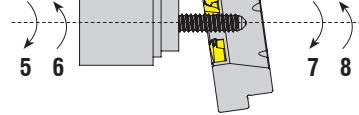

Dirección de Giro de la Unidad Giratoria
 Sens de Rotation de l'unité de Tourbillonnement
 Turning Direction of Whirling Unit

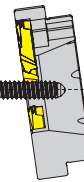

Especificaciones de la Máquina Caractéristiques de la Machine Machine Specifications		Especificaciones de Material Spécifications des Matériaux Material Specifications
Fabricante de la Máquina Fabricant de Machines Machine Manufacturer		Material (DIN, AISI, etc.) Matériau (DIN, AISI, etc.) Material (DIN, AISI etc.)
Modelo de Máquina Modèle de Machine Machine Model		Diámetro de Materia Prima Diamètre des Matières Premières Raw Material Diameter
Fabricante de Herramientas En Vivo Fabricant de l'outil Live Tool Manufacturer		Perfil de Hilo Profil de Discussion Thread Profile
Wirbelspindel Unità Per Utensili Tipo Whirling Driven Whirling Unit		Perfil Dibujo Técnico Fiche Technique Du Profile Profile Technical Drawing
Eje Y Axe Y Y Axis	Existe Disponible Yes <input type="checkbox"/> Ninguna Aucun No <input type="checkbox"/>	Tono Pas Pitch
Refrigerante de Alta Presión Liquide de Refroidissement à Haute Pression High Pressure Cooling	Existe Disponible Yes <input type="checkbox"/> Ninguna Aucun No <input type="checkbox"/>	Eingängig Un Inizio Single Tooth
Posición de Inicio de Corte Position de Départ de Coupe Cutting Start Position	1 <input type="checkbox"/> 2 <input type="checkbox"/> 3 <input type="checkbox"/> 4 <input type="checkbox"/>	Dos Comienzos Deux Mises en Chantier Double Tooth
Dirección de Giro de la Unidad Giratoria Sens de Rotation de l'unité de Tourbillonnement Turning Direction of Whirling Unit	5 <input type="checkbox"/> 6 <input type="checkbox"/>	Nombre del Cliente / Nom du Client / Customer Name :
Dirección de Giro de la Pieza de Trabajo Sens de Rotation de la Pièce Turning Direction of Workpiece	7 <input type="checkbox"/> 8 <input type="checkbox"/>	Persona Responsable / Responsable / Responsible Person :
α Angulo Angle α a Angle	Nota: este ángulo afecta el rendimiento de las inserciones. Si no se conoce, el cuerpo de la herramienta debe enviarse a AKKO. Note: Cet angle affecte la performance des plaquettes. Si ne pas connu, le corps d'outil doit être envoyer à AKKO. Note: This angle effects the performance of inserts. If doesn't known, tool body should be send to AKKO.	
Nota / Note / Note :		

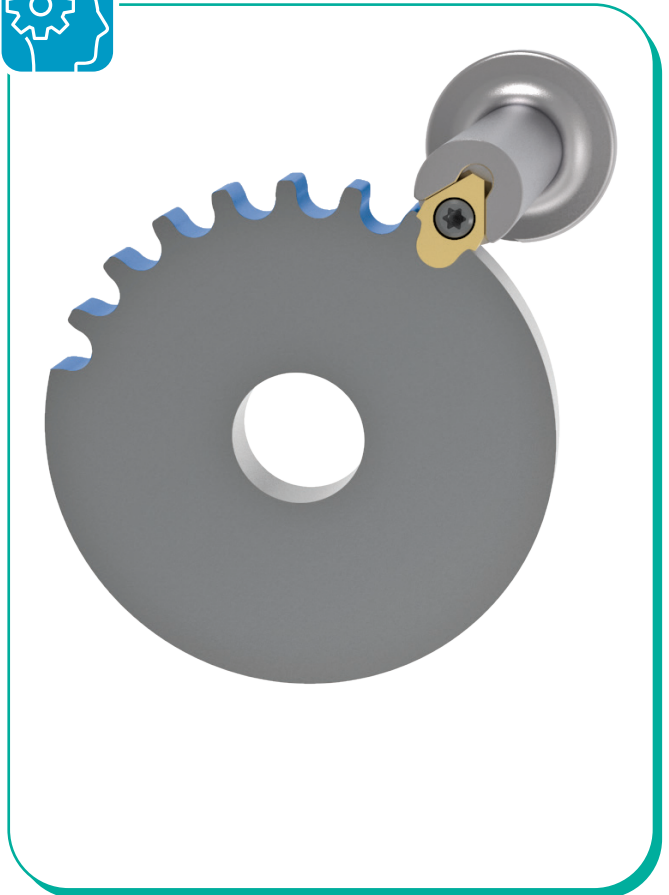
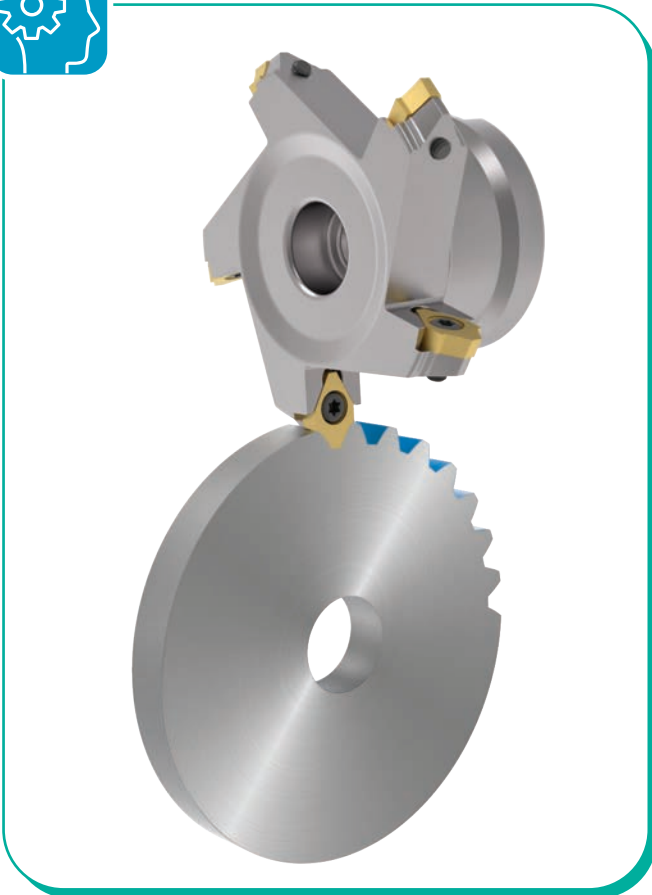
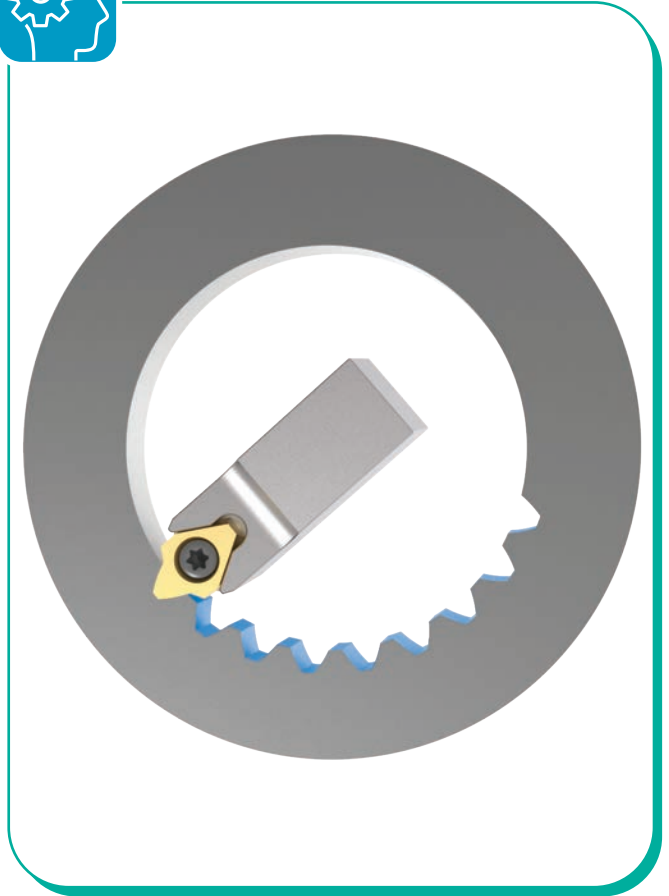
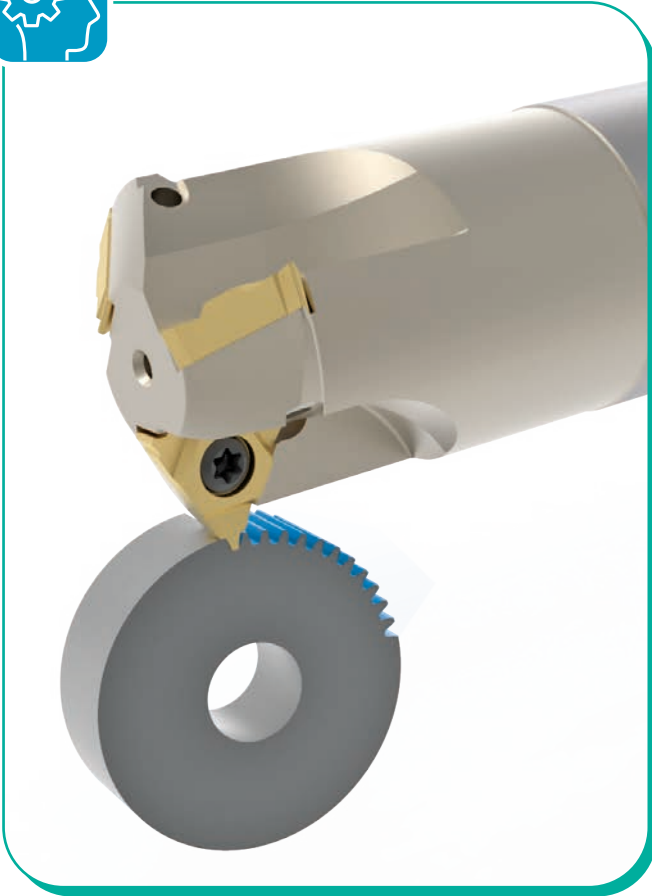

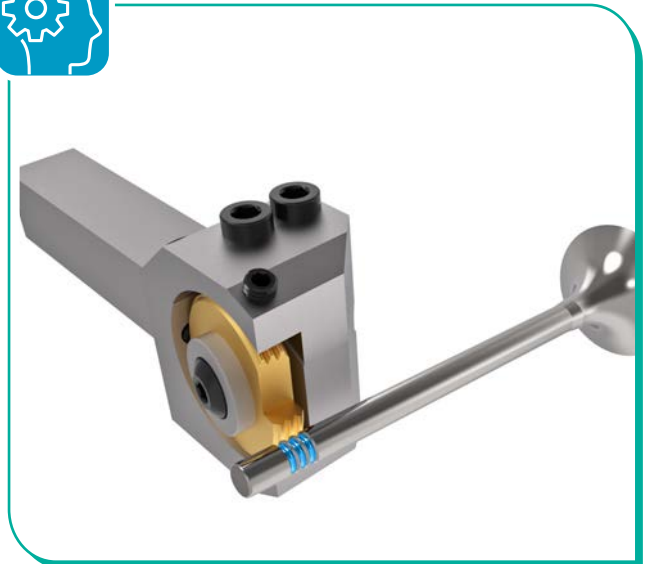
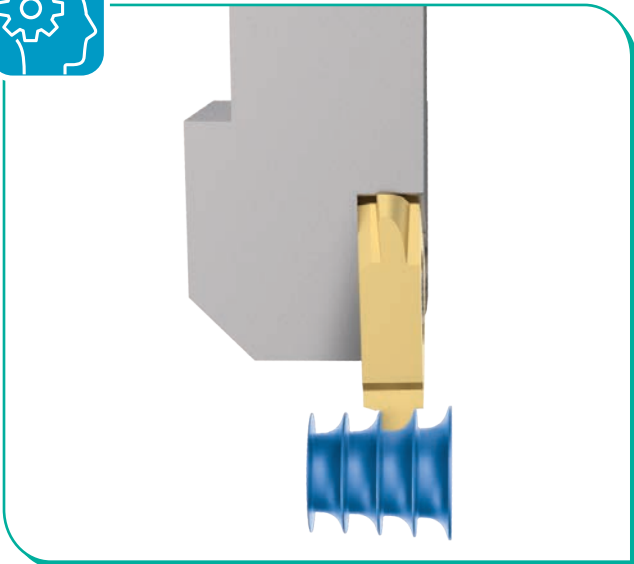
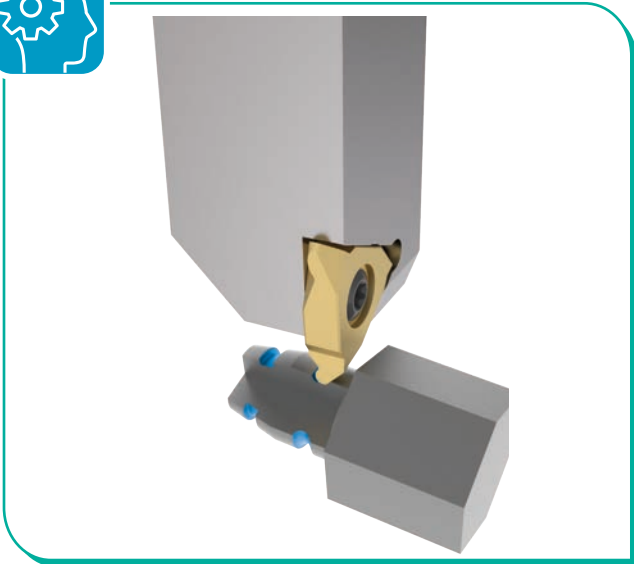
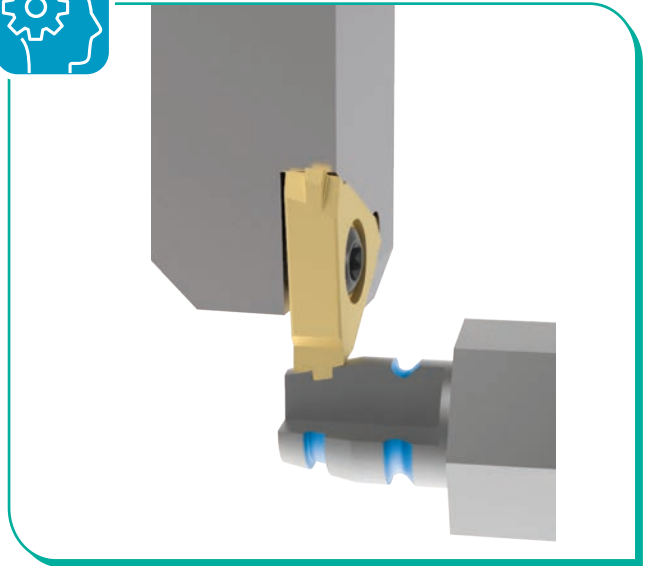
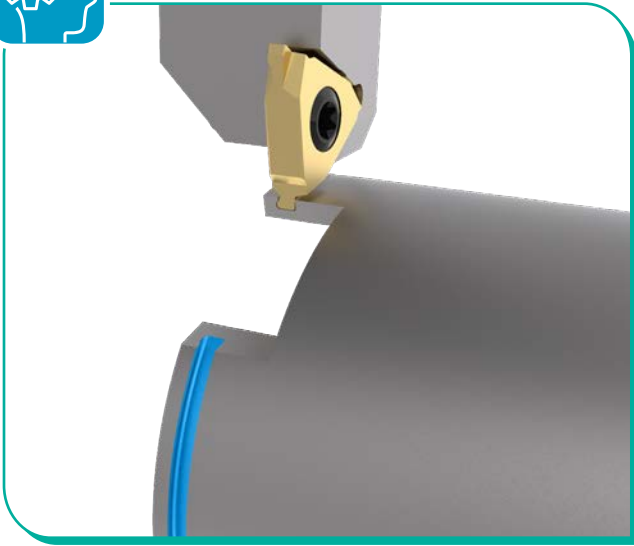



PORTA HERRAMIENTAS DE TORNADO EXTERNO
PORTE-OUTILS POUR TOURNAGE EXTERIEUR
EXTERNAL TURNING TOOLHOLDERS





1 P S K N R

1 Método de Montaje del Inserto / Méthode de Montage de Plaquette / Clamping Method of Insert

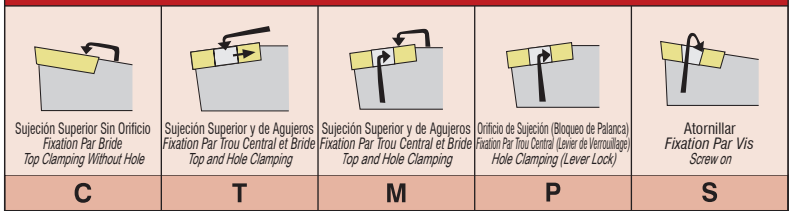

2 Tipo de Inserto / Forme de Plaquette / Insert Shape

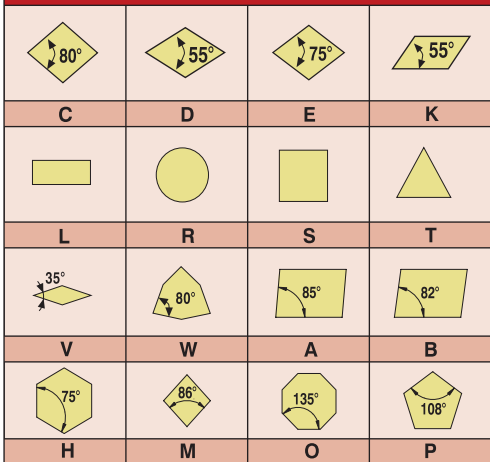

3 Geométrica de la Barra / Angle D'attaque / Tool Holder Shape Bar Geometry

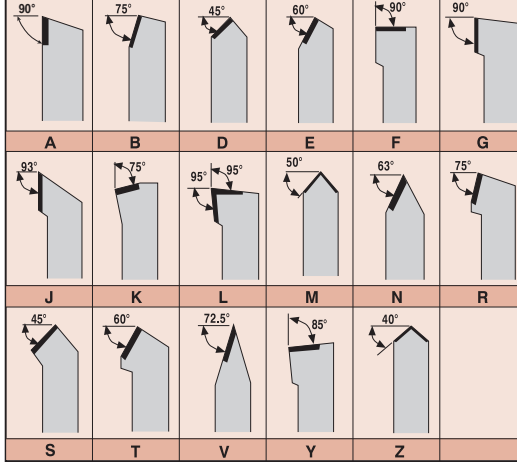

4 Inserto de ángulo libre / Angle de Dèpote de l'arete de Coupe Principale / Insert Clearance Angle Freiwinkel

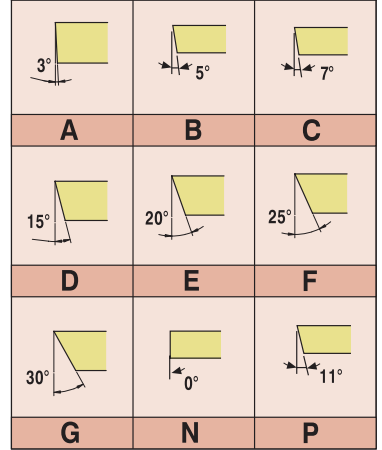

6 25 25 - M 12 C

5 Dirección de Corte / Sens de Coupe / Cutting Direction

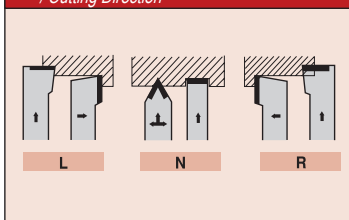

6 Altura del Filo / Hauteur de l'outil / Cutting Edge Height

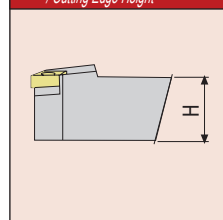

7 Ancho de el Vastago / Largeur de l'outil / Shank Width

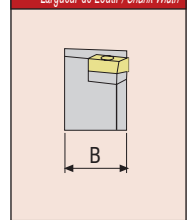

8 Longitud del Vastago / Longueur de l'outil LF(mm) / Shank Length

A - 32	H - 100	Q - 180	x-special
B - 40	J - 110	R - 200	
C - 50	K - 125	S - 250	
D - 60	L - 140	T - 300	
E - 70	M - 150	U - 350	
F - 80	N - 160	V - 400	
G - 90	P - 170	W - 450	

9 Longitud del Filo / Longueur d'arete de Coupe / Cutting Edge Length

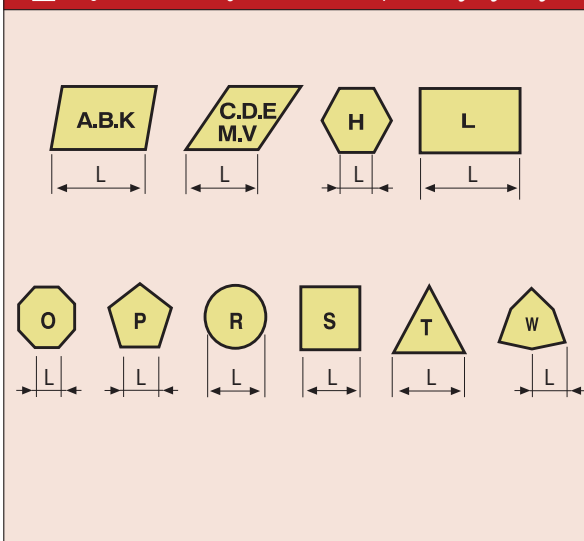

10 Abrazadera de Cuñas / Mode de Fixation Wedge Clamp

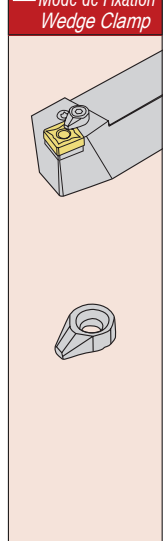



konusulan
the spoken kalite...
quality...

T-SYSTEM

PORTA HERRAMIENTAS DE TORNEADO EXTERNO SISTEMA-T
PORTE-OUTILS POUR TOURNAGE EXTERIEUR SYSTEME-T
T-SYSTEM EXTERNAL TURNING TOOLHOLDERS



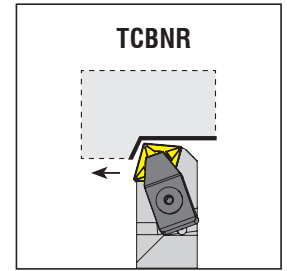
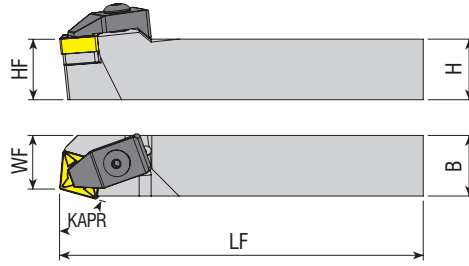

Código del Inserto Le Code de Commande Ordering Code	Dimension (mm) Dimension (mm)						Inserto Plaquelette Insert	Recambios / Pièces de Rechange / Spare Parts						
	Stock Stock		HF=H	B	LF	WF		Abrazadera de Cuñas Mode de Fixation Wedge Clamp	Tornillo de Sujeción Vis de Fixation Wedge Screw	Cuñas Assise Shim	Tornillo de Placa Vis a Assise Shim Screw	Resorte Printemps Spring	Arandela Timbre Washer	Llaves Allen Clés Allen Allen Wrench
	R	L												
TCBNR/L 2525 M16	●	●	25	25	150	22								

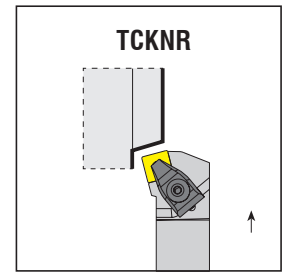
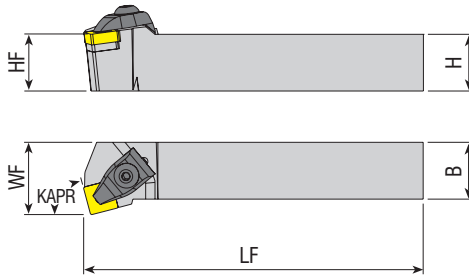

Código del Inserto Le Code de Commande Ordering Code	Dimension (mm) Dimension (mm)						Inserto Plaquelette Insert	Recambios / Pièces de Rechange / Spare Parts						
	Stock Stock		HF=H	B	LF	WF		Abrazadera de Cuñas Mode de Fixation Wedge Clamp	Tornillo de Sujeción Vis de Fixation Wedge Screw	Cuñas Assise Shim	Tornillo de Placa Vis a Assise Shim Screw	Anillo Bague Ring	Arandela Timbre Washer	Llaves Allen Clés Allen Allen Wrench
	R	L												
TCKNR/L 2020 K12	●	●	20	20	125	25								
2525 M12	●	●	25	25	150	32	CNM. 1204..	ATK-02	AKV-30-M6x22	AACN-3-0001	AAV-02-M5x12	AS-01	ABPL-01	AAL-03-3
3232 P12	●	●	32	32	170	40								
2525 M16	●	●	25	25	150	32	CNM. 1606..	ATK-04	AKV-19-M7x25	AACN-3-0002	AAV-05-M6x15	AS-02	ABPL-02	AAL-05-4
3232 P16	●	●	32	32	170	40								

R: Derecha / Droite / Right L: Izquierda / Gauche / Left

● En Existencia / En stock / In Stock ○ Artículo sin Existencia / Indisponible en Stock / Non Stock Item

Ejemplo de Pedido / Exemple de Commande / Ordering Example

1 Piezas / pcs. / pcs. TCBNR 2525 M16

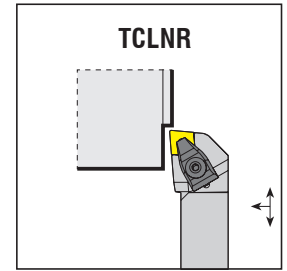
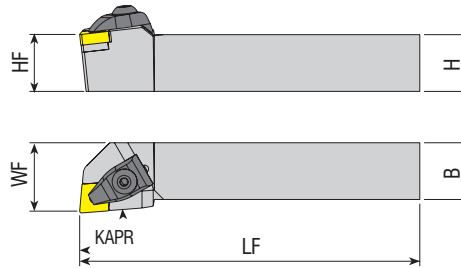
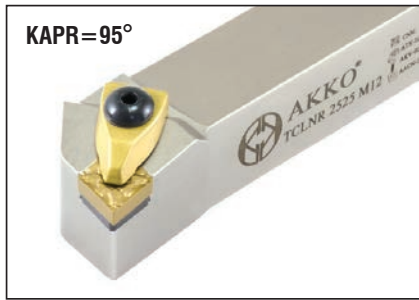

Código del Inserto Le Code de Commande Ordering Code	Stock Stock		Dimension (mm) Dimension (mm)				Inserto Plaquette Insert	Recambios / Pièces de Rechange / Spare Parts							
	R	L	HF=H	B	LF	WF		Abrazadera de Cuñas Mode de Fixation Wedge Clamp	Tornillo de Sujeción Vis de Fixation Wedge Screw	Cuñas Assise Shim	Tornillo de Placa Vis a Assise Shim Screw	Anillo Bague Ring	Arandela Timbre Washer	Llaves Allen Clés Allen Allen Wrench	
TCLNR/L 2020 K12	●	●	20	20	125	25	CNM. 1204..								
2525 M12	●	●	25	25	150	32									
3232 P12	●	●	32	32	170	40									
4040 S12	●	●	40	40	250	50									
5050 S12	●	●	50	50	250	63	CNM. 1606..								
2525 M16	●	●	25	25	150	32									
3232 P16	●	●	32	32	170	40									

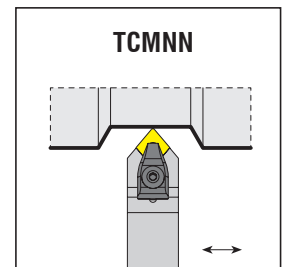
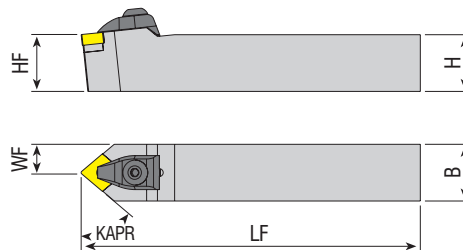

Código del Inserto Le Code de Commande Ordering Code	Stock Stock		Dimension (mm) Dimension (mm)				Inserto Plaquette Insert	Recambios / Pièces de Rechange / Spare Parts							
			HF=H	B	LF	WF		Abrazadera de Cuñas Mode de Fixation Wedge Clamp	Tornillo de Sujeción Vis de Fixation Wedge Screw	Cuñas Assise Shim	Tornillo de Placa Vis a Assise Shim Screw	Anillo Bague Ring	Arandela Timbre Washer	Llaves Allen Clés Allen Allen Wrench	
TCMNN 1616 H12	●		16	16	100	8	CNM. 1204..								
2020 K12	●		20	20	125	10									
2525 M12	●		25	25	150	12.5									
3232 P12	●		32	32	170	16									
2525 M16	●		25	25	150	12.5	CNM. 1606..								
3232 P16	●		32	32	170	16									
4040 S16	○		40	40	250	20									

R: Derecha / Droite / Right L: Izquierda / Gauche / Left

● En Existencia / En stock / In Stock ○ Artículo sin Existencia / Indisponible en Stock / Non Stock Item

Ejemplo de Pedido / Exemple de Commande / Ordering Example

1 Piezas / pcs. / pcs. TCLNR 2020 K12

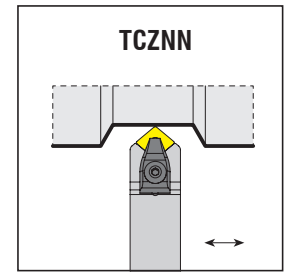
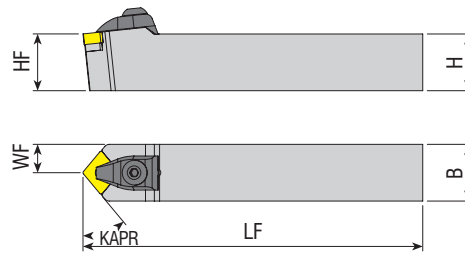

Código del Inserto Le Code de Commande Ordering Code	Stock		Dimension (mm) Dimension (mm)				Inserto Plaquette Insert	Recambios / Pièces de Rechange / Spare Parts														
	Stock	Stock	HF=H	B	LF	WF		Abrazadera de Cuñas Mode de Fixation Wedge Clamp	Tornillo de Sujeción Vis de Fixation Wedge Screw	Cuñas Assise Shim	Tornillo de Placa Vis a Assise Shim Screw	Anillo Bague Ring	Arandela Timbre Washer	Llaves Allen Clés Allen Allen Wrench								
TCZNN 2020 K12	●		20	20	125	10																
2525 M12	●		25	25	150	12.5									CNM. 1204..	ATK-02	AKV-30-M6x22	AACN-3-0001	AAV-02-M5x12	AS-01	ABPL-01	AAL-03-3
3232 P12	●		32	32	170	16																
2525 M16	●		25	25	150	12.5	CNM. 1606..															
3232 P16	●		32	32	170	16									ATK-04	AKV-19-M7x25	AACN-3-0002	AAV-05-M6x15	AS-02	ABPL-02	AAL-05-4	

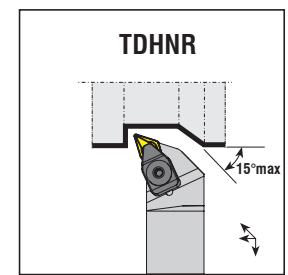
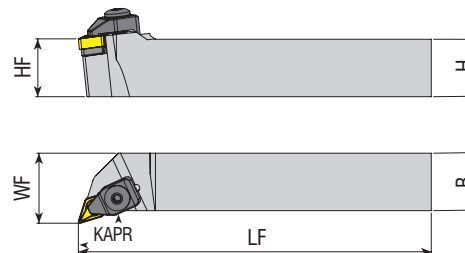

Código del Inserto Le Code de Commande Ordering Code	Stock		Dimension (mm) Dimension (mm)				Inserto Plaquette Insert	Recambios / Pièces de Rechange / Spare Parts						
	R	L	HF=H	B	LF	WF		Abrazadera de Cuñas Mode de Fixation Wedge Clamp	Tornillo de Sujeción Vis de Fixation Wedge Screw	Cuñas Assise Shim	Tornillo de Placa Vis a Assise Shim Screw	Anillo Bague Ring	Arandela Timbre Washer	Llaves Allen Clés Allen Allen Wrench
TDHNR/L 2525 M11	○	●	25	25	150	31								
2020 K15	●	●	20	20	125	25								
2525 M15	●	●	25	25	150	32	DNM. 1506..							
3232 P15	●	●	32	32	170	40								

R: Derecha / Droite / Right L: Izquierda / Gauche / Left

● En Existencia / En stock / In Stock ○ Artículo sin Existencia / Indisponible en Stock / Non Stock Item

Ejemplo de Pedido / Exemple de Commande / Ordering Example

1 Piezas / pcs. / pcs. TCZNN 2020 K12

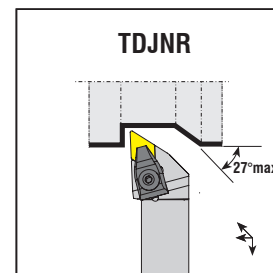
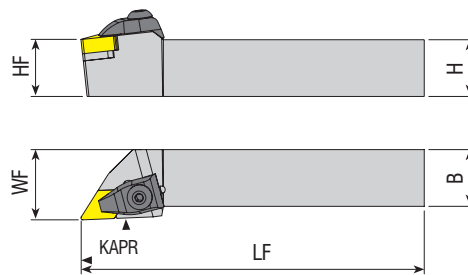

Código del Inserto Le Code de Commande Ordering Code	Dimension (mm) Dimension (mm) Dimension (mm)						Inserto Plaquette Insert	Recambios / Pièces de Rechange / Spare Parts							
	Stock Stock Stock		HF=H	B	LF	WF		Abrazadera de Cuñas Mode de Fixation Wedge Clamp	Tornillo de Sujeción Vis de Fixation Wedge Screw	Cuñas Assise Shim	Tornillo de Placa Vis a Assise Shim Screw	Anillo Bague Ring	Arandela Timbre Washer	Llaves Allen Clés Allen Allen Wrench	
	R	L													
TDJNR/L 1616 H11	●	●	16	16	100	20	DNM. 1104..	ATK-01	AKV-01-M5x22	AADN-2-0001	AAV-04-M5x12	-			
2020 K11	●	●	20	20	125	25									
2525 M11	●	●	25	25	150	32									
2020 K15	●	●	20	20	125	25	DNM. 1506..	ATK-02	AKV-30-M6x22	AADN-3-0001	AAV-02-M5x12	AS-01	ABPL-01	AAL-03-3	
2525 M15	●	●	25	25	150	32									
3232 P15	●	●	32	32	170	40									
4040 S15	○	○	40	40	250	50	DNM. 1504..	ATK-02	AKV-30-M6x22	AADN-2-0003	AAV-02-M5x12	AS-01			
5050 S15	○	○	50	50	250	63									
2020 K1504	●	●	20	20	125	25									
2525 M1504	●	●	25	25	150	32									
3232 P1504	●	●	32	32	170	40									
4040 S1504	●	●	40	40	250	50									

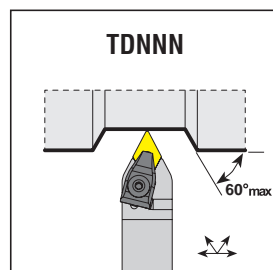
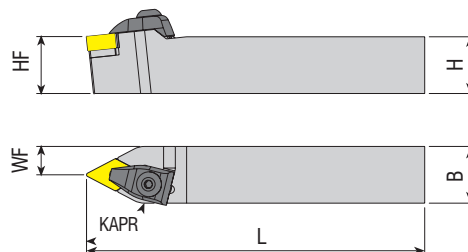

Código del Inserto Le Code de Commande Ordering Code	Dimension (mm) Dimension (mm) Dimension (mm)						Inserto Plaquette Insert	Recambios / Pièces de Rechange / Spare Parts						
	Stock Stock Stock		HF=H	B	LF	WF		Abrazadera de Cuñas Mode de Fixation Wedge Clamp	Tornillo de Sujeción Vis de Fixation Wedge Screw	Cuñas Assise Shim	Tornillo de Placa Vis a Assise Shim Screw	Anillo Bague Ring	Arandela Timbre Washer	Llaves Allen Clés Allen Allen Wrench
	R	L												
TDNNN 1616 H11	●	●	16	16	100	8	DNM. 1104..	ATK-01	AKV-01-M5x22	AADN-2-0001	AAV-04-M5x12	-		
2020 K11	●	●	20	20	125	10								
2525 M11	●	●	25	25	150	12.5								
2020 K15	●	●	20	20	125	10	DNM. 1506..	ATK-02	AKV-30-M6x22	AADN-3-0001	AAV-02-M5x12	AS-01	ABPL-01	AAL-03-3
2525 M15	●	●	25	25	150	12.5								
3232 P15	●	●	32	32	170	16								
4040 S15	○	○	40	40	250	20								
5050 S15	○	○	50	50	250	25								

R: Derecha / Droite / Right L: Izquierda / Gauche / Left

● En Existencia / En stock / In Stock ○ Artículo sin Existencia / Indisponible en Stock / Non Stock Item

Ejemplo de Pedido / Exemple de Commande / Ordering Example

1 Piezas / pcs. / pcs. TDJNR 1616 H11

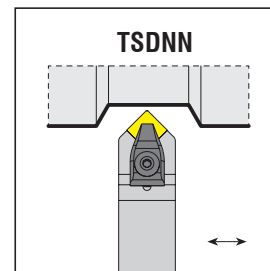
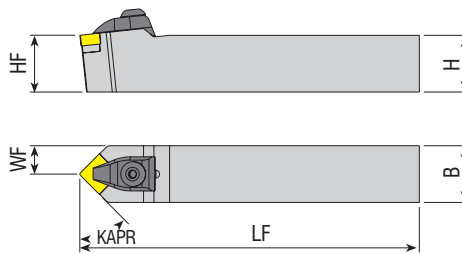

Código del Inserto Le Code de Commande Ordering Code	Stock Stock		Dimension (mm) Dimension (mm)				Inserto Plaquette Insert	Recambios / Pièces de Rechange / Spare Parts						
	R	L	HF=H	B	LF	WF		Abrazadera de Cuñas Mode de Fixation Wedge Clamp	Tornillo de Sujeción Vis de Fixation Wedge Screw	Cuñas Assise Shim	Tornillo de Placa Vis a Assise Shim Screw	Anillo Bague Ring	Arandela Timbre Washer	Llaves Allen Clés Allen Allen Wrench
TSDNN 1616 H12	●		16	16	100	8	SNM. 1204..							
2020 K12	●		20	20	125	10								
2525 M12	●		25	25	150	12.5								
3232 P12	●		32	32	170	16								
2525 M15	○		25	25	150	12.5	SNM. 1506..							
3232 P15	●		32	32	170	16								
4040 S15	○		40	40	250	20								

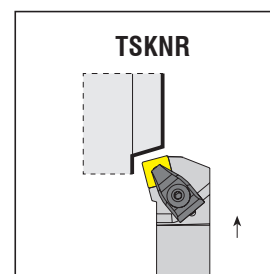
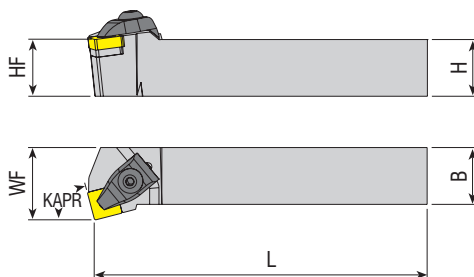

Código del Inserto Le Code de Commande Ordering Code	Stock Stock		Dimension (mm) Dimension (mm)				Inserto Plaquette Insert	Recambios / Pièces de Rechange / Spare Parts						
	R	L	HF=H	B	LF	WF		Abrazadera de Cuñas Mode de Fixation Wedge Clamp	Tornillo de Sujeción Vis de Fixation Wedge Screw	Cuñas Assise Shim	Tornillo de Placa Vis a Assise Shim Screw	Anillo Bague Ring	Arandela Timbre Washer	Llaves Allen Clés Allen Allen Wrench
TSKNR/L 2020 K12	●	●	20	20	125	25	SNM. 1204..							
2525 M12	●	●	25	25	150	32								
3232 P12	●	●	32	32	170	40								
3232 P15	●	●	32	32	170	40								
							SNM. 1506..							

R: Derecha / Droite / Right L: Izquierda / Gauche / Left

● En Existencia / En stock / In Stock ○ Artículo sin Existencia / Indisponible en Stock / Non Stock Item

Ejemplo de Pedido / Exemple de Commande / Ordering Example

1 Piezas / pcs. / pcs. TSDNN 1616 H12

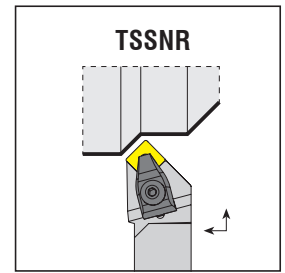
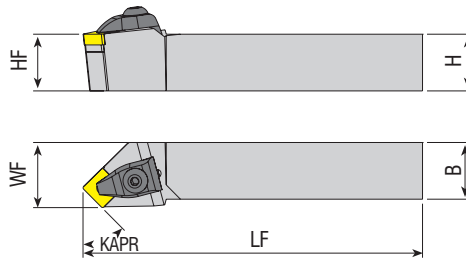

Código del Inserto Le Code de Commande Ordering Code	Stock Stock			Dimension (mm) Dimension (mm)			Inserto Plaquette Insert	Abrazadera de Cuñas Mode de Fixation Wedge Clamp	Tornillo de Sujeción Vis de Fixation Wedge Screw	Cuñas Assise Shim	Tornillo de Placa Vis a Assise Shim Screw	Anillo Bague Ring	Arandela Timbre Washer	Llaves Allen Clés Allen Allen Wrench							
	R	L	HF=H	B	LF	WF															
TSSNR/L 2020 K12	●	●	20	20	125	25															
2525 M12	●	●	25	25	150	SNM. 1204..									ATK-02	AKV-30-M6x22	AASN-3-0004	AAV-02-M5x12	AS-01	ABPL-01	AAL-03-3
3232 P12	●	●	32	32	170	40															
2525 M15	●	●	25	25	150	32	SNM. 1506..	ATK-04	AKV-19-M7x25	AASN-3-0023	AAV-05-M6x15	AS-02	ABPL-02	AAL-05-4							
3232 P15	●	●	32	32	170	40															

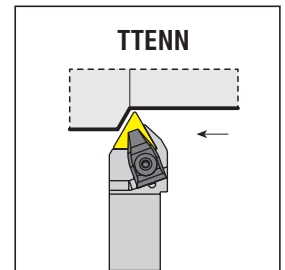
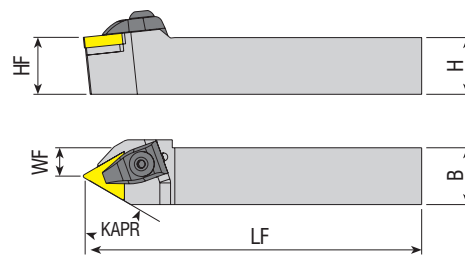

Código del Inserto Le Code de Commande Ordering Code	Stock Stock			Dimension (mm) Dimension (mm)			Inserto Plaquette Insert	Abrazadera de Cuñas Mode de Fixation Wedge Clamp	Tornillo de Sujeción Vis de Fixation Wedge Screw	Cuñas Assise Shim	Tornillo de Placa Vis a Assise Shim Screw	Anillo Bague Ring	Arandela Timbre Washer	Llaves Allen Clés Allen Allen Wrench								
	R	L	HF=H	B	LF	WF																
TTENN 2020 K16	●		20	20	125	10																
2525 M16	●		25	25	150	12.5									TNM. 1604..	ATK-01	AKV-01-M5x22	AATN-2-0002	AAV-03-M5x12	-	ABPL-01	AAL-03-3
3232 P16	●		32	32	170	16																
2525 M22	●		25	25	150	12.5	TNM. 2204..	ATK-02	AKV-30-M6x22	AATN-3-0015	AAV-02-M5x12	AS-01										
3232 P22	●		32	32	170	16																
4040 S22	○		40	40	250	20																

R: Derecha / Droite / Right L: Izquierda / Gauche / Left

● En Existencia / En stock / In Stock ○ Artículo sin Existencia / Indisponible en Stock / Non Stock Item

Ejemplo de Pedido / Exemple de Commande / Ordering Example

1 Piezas / pcs. / pcs. TSSNR 2020 K12

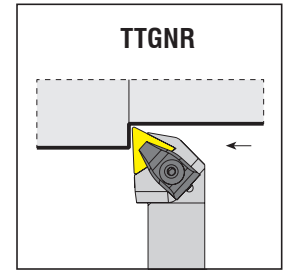
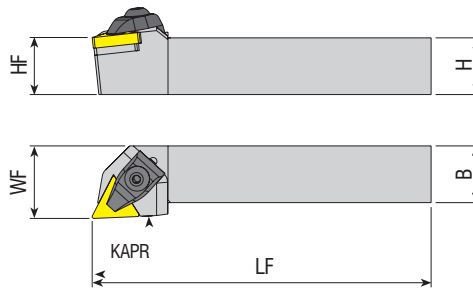
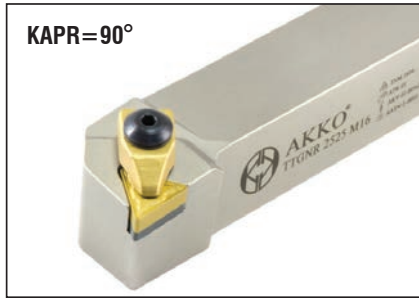

Código del Inserto Le Code de Commande Ordering Code		Stock Stock		Dimension (mm) Dimension (mm)			Inserto Plaquette Insert	Recambios / Pièces de Rechange / Spare Parts							
		R	L	HF=H	B	LF		WF	Abrazadera de Cuñas Mode de Fixation Wedge Clamp	Tornillo de Sujeción Vis de Fixation Wedge Screw	Cuñas Assise Shim	Tornillo de Placa Vis a Assise Shim Screw	Anillo Bague Ring	Arandela Timbre Washer	Llaves Allen Clés Allen Allen Wrench
TTGNR/L 2020 K16		●	●	20	20	125	25	TNM. 1604..	ATK-01	AKV-01-M5x22	AATN-2-0002	AAV-03-M5x12	-	ABPL-01	AAL-03-3
2525 M16		●	●	25	25	150	32								
3232 P16		●	●	32	32	170	40								
2525 M22		●	●	25	25	150	32	TNM. 2204..	ATK-02	AKV-30-M6x22	AATN-3-0015	AAV-02-M5x12	AS-01	ABPL-01	AAL-03-3
3232 P22		●	●	32	32	170	40								
4040 S22		●	○	40	40	250	50								

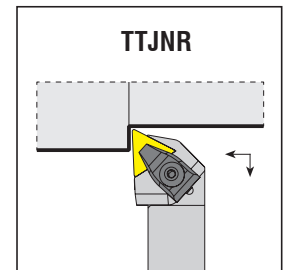
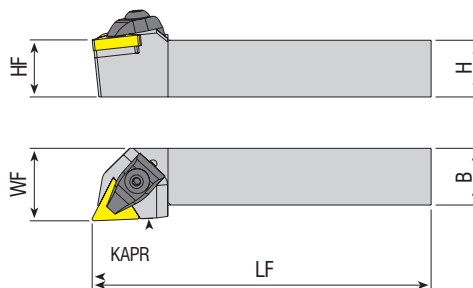

Código del Inserto Le Code de Commande Ordering Code		Stock Stock		Dimension (mm) Dimension (mm)			Inserto Plaquette Insert	Recambios / Pièces de Rechange / Spare Parts							
		R	L	HF=H	B	LF		WF	Abrazadera de Cuñas Mode de Fixation Wedge Clamp	Tornillo de Sujeción Vis de Fixation Wedge Screw	Cuñas Assise Shim	Tornillo de Placa Vis a Assise Shim Screw	Anillo Bague Ring	Arandela Timbre Washer	Llaves Allen Clés Allen Allen Wrench
TTJNR/L 2020 K16		●	●	20	20	125	25	TNM. 1604..	ATK-01	AKV-01-M5x22	AATN-2-0002	AAV-03-M5x12	-	ABPL-01	AAL-03-3
2525 M16		●	●	25	25	150	32								
3232 P16		●	●	32	32	170	40								
2525 M22		●	●	25	25	150	32	TNM. 2204..	ATK-02	AKV-30-M6x22	AATN-3-0015	AAV-02-M5x12	AS-01	ABPL-01	AAL-03-3
3232 P22		●	●	32	32	170	40								
4040 S22		○	○	40	40	250	50								

R: Derecha / Droite / Right L: Izquierda / Gauche / Left

● En Existencia / En stock / In Stock ○ Artículo sin Existencia / Indisponible en Stock / Non Stock Item

Ejemplo de Pedido / Exemple de Commande / Ordering Example

1 Piezas / pcs. / pcs. TTGNR 2020 K16

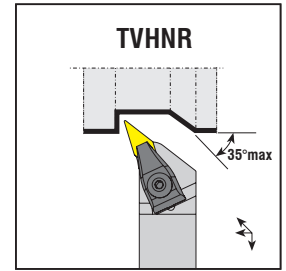
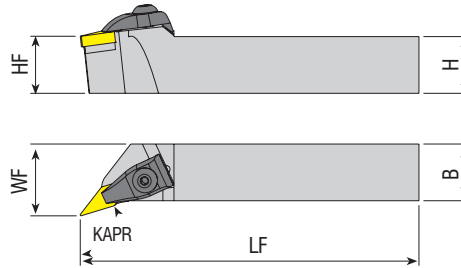

Código del Inserto Le Code de Commande Ordering Code	Stock						Dimension (mm) Dimension (mm)								Recambios / Pièces de Rechange / Spare Parts									
	Stock		Stock		Stock		Dimension (mm)		Dimension (mm)		Dimension (mm)		Inserto	Abrazadera de Cuñas	Tornillo de Sujeción	Cuñas	Tornillo de Placa	Anillo	Arandela	Llaves Allen				
	R	L	HF=H	B	LF	WF	Inserto	Abrazadera de Cuñas	Tornillo de Sujeción	Cuñas	Tornillo de Placa	Anillo	Arandela	Llaves Allen										
TVHNR/L 2020 K16	●	●	20	20	125	25	VNM. 1604..	ATK-03	AKV-30-M6x22	AAVN-2-0002	AAV-04-M5x12	AS-01	ABPL-01	AAL-03-3										
2525 M16	●	●	25	25	150	32																		
3232 P16	●	●	32	32	170	40																		

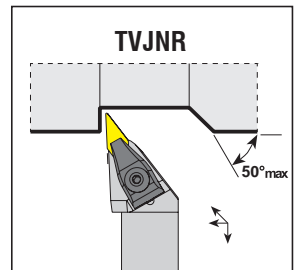
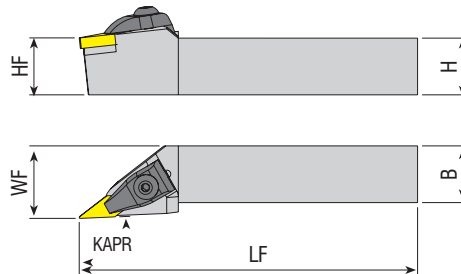

Código del Inserto Le Code de Commande Ordering Code	Stock						Recambios / Pièces de Rechange / Spare Parts													
	Stock		Stock		Stock		Dimension (mm)		Dimension (mm)		Dimension (mm)		Inserto	Abrazadera de Cuñas	Tornillo de Sujeción	Cuñas	Tornillo de Placa	Anillo	Arandela	Llaves Allen
	R	L	HF=H	B	LF	WF	Inserto	Abrazadera de Cuñas	Tornillo de Sujeción	Cuñas	Tornillo de Placa	Anillo	Arandela	Llaves Allen						
TVJNR/L 2020 K16	●	●	20	20	125	25	VNM. 1604..	ATK-03	AKV-30-M6x22	AAVN-2-0002	AAV-04-M5x12	AS-01	ABPL-01	AAL-03-3						
2525 M16	●	●	25	25	150	32														
3232 P16	●	●	32	32	170	40														

R: Derecha / Droite / Right L: Izquierda / Gauche / Left
 ● En Existencia / En stock / In Stock ○ Artículo sin Existencia / Indisponible en Stock / Non Stock Item

Ejemplo de Pedido / Exemple de Commande / Ordering Example
 1 Piezas / pcs. / pcs. TVHNR 2020 K16

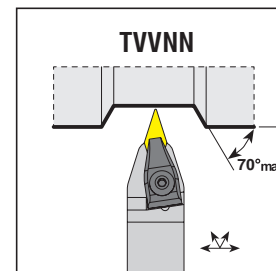
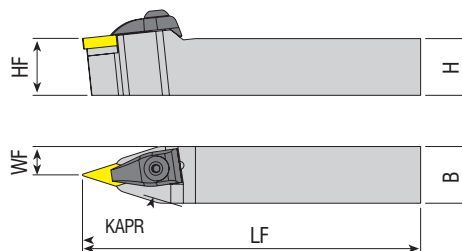

Código del Inserto Le Code de Commande Ordering Code	Stock Stock	Dimension (mm) Dimension (mm)					Inserto Plaquette Insert	Recambios / Pièces de Rechange / Spare Parts												
		HF=H	B	LF	WF	Abrazadera de Cuñas Mode de Fixation Wedge Clamp		Tornillo de Sujeción Vis de Fixation Wedge Screw	Cuñas Assise Shim	Tornillo de Placa Vis a Assise Shim Screw	Anillo Bague Ring	Arandela Timbre Washer	Llaves Allen Clés Allen Allen Wrench							
TVVNN 2020 K16	●	20	20	125	10	VNM. 1604..														
2525 M16	●	25	25	150	12.5									ATK-03	AKV-30-M6x22	AAVN-2-0002	AAV-04-M5x12	AS-01	ABPL-01	AAL-03-3
3232 P16	●	32	32	170	16															

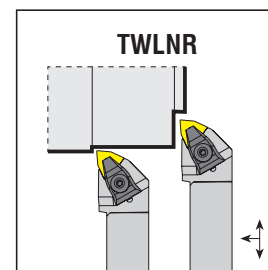
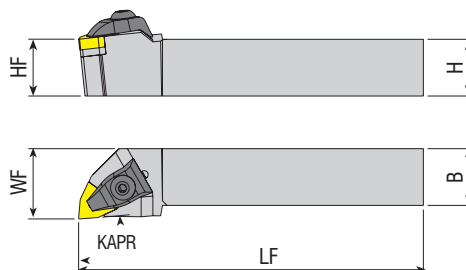
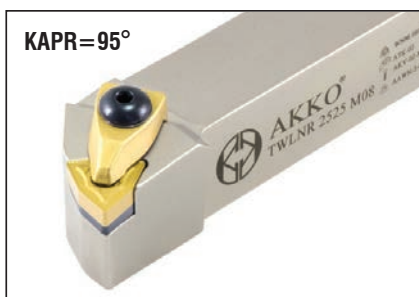

Código del Inserto Le Code de Commande Ordering Code	Stock Stock		Dimension (mm) Dimension (mm)					Inserto Plaquette Insert	Recambios / Pièces de Rechange / Spare Parts												
	R	L	HF=H	B	LF	WF	Abrazadera de Cuñas Mode de Fixation Wedge Clamp		Tornillo de Sujeción Vis de Fixation Wedge Screw	Cuñas Assise Shim	Tornillo de Placa Vis a Assise Shim Screw	Anillo Bague Ring	Arandela Timbre Washer	Llaves Allen Clés Allen Allen Wrench							
TWLNR/L 1616 H06	●	●	16	16	100	20	WNM. 0604..														
2020 K06	●	●	20	20	125	25									ATK-01	AKV-01-M5x22	AAWN-SW317	AAV-01-M3x10	-		
2525 M06	●	●	25	25	150	32															
2020 K08	●	●	20	20	125	25	WNM. 0804..														
2525 M08	●	●	25	25	150	32									ATK-02	AKV-30-M6x22	AAWN-3-0001	AAV-02-M5x12	AS-01	ABPL-01	AAL-03-3
3232 P08	●	●	32	32	170	40															
4040 S08	●	●	40	40	250	50															
5050 S08	○	○	50	50	250	63															

R: Derecha / Droite / Right L: Izquierda / Gauche / Left

● En Existencia / En stock / In Stock ○ Artículo sin Existencia / Indisponible en Stock / Non Stock Item

Ejemplo de Pedido / Exemple de Commande / Ordering Example

1 Piezas / pcs. / pcs. TVVNN 2020 K16



konusulan
the spoken kalite...
quality...

T-SYSTEM

SISTEMA T PORTA HERRAMIENTAS DE TORNEADO EXTERNO CON AGUJERO REFRIGERANTE

SYSTÈME-T PORTE-OUTILS AVEC TROU D'AROSAGE TOURNAGE EXTERIEUR

T-SYSTEM EXTERNAL TURNING TOOLHOLDERS WITH COOLANT HOLE



ESCANEAR PARA MAS MÁS DETALLES

SCAN ME POUR PLUS DE DÉTAILS

SCAN ME FOR MORE DETAILS

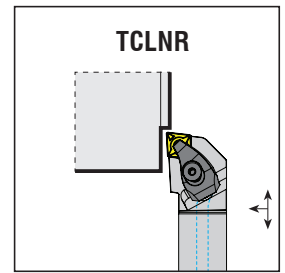
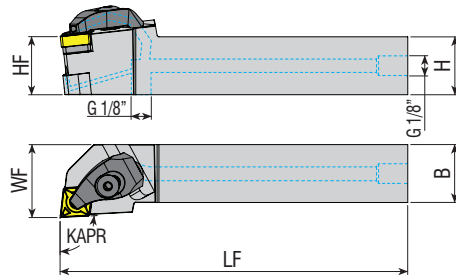
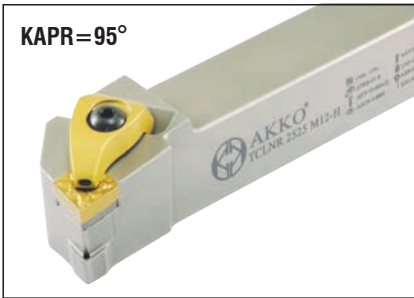

Código del Inserto
Le Code de Commande
Ordering Code

Stock Stock		Dimension (mm) Dimension (mm) Dimension (mm)				
R	L	HF=H	B	LF	WF	

TCLNR/L 2020 K12-H	●	●	20	20	125	25
2525 M12-H	●	●	25	25	150	32
3232 P12-H	●	●	32	32	170	40

Inserto Plaquette Insert	Abrazadera de Cuñas Molle de Fixation Wedge Clamp	Tornillo de Sujeción Vis de Fixation Wedge Screw	Cuñas Assise Shim	Tornillo de Placa Vis a Assise Shim Screw	Resorte Printemps Spring	Anillo Bague Ring	Pin de Roscado Tige Fileté Threaded Pin	Llaves Allen Clés Allen Allen Wrench
--------------------------------	---	--	-------------------------	---	--------------------------------	-------------------------	---	--

CNM. 1204..	ATKH-01-R ATKH-02-L	AKV-33-M6x22	AACN-3-0001	AAV-13-M5x8	AKY-01	AXR-01	2705-G1/8x5.5	AAL-03-3
--------------------	------------------------	--------------	-------------	-------------	--------	--------	---------------	----------

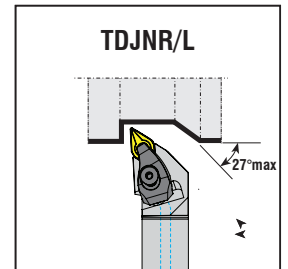
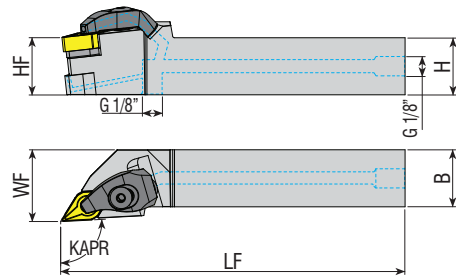

Código del Inserto
Le Code de Commande
Ordering Code

Stock Stock		Dimension (mm) Dimension (mm) Dimension (mm)				
R	L	HF=H	B	LF	WF	

TDJNR/L 2020 K15-H	●	●	20	20	125	25
2525 M15-H	●	●	25	25	150	32
3232 P15-H	●	●	32	32	170	40

Inserto Plaquette Insert	Abrazadera de Cuñas Molle de Fixation Wedge Clamp	Tornillo de Sujeción Vis de Fixation Wedge Screw	Cuñas Assise Shim	Tornillo de Placa Vis a Assise Shim Screw	Resorte Printemps Spring	Anillo Bague Ring	Pin de Roscado Tige Fileté Threaded Pin	Llaves Allen Clés Allen Allen Wrench
--------------------------------	---	--	-------------------------	---	--------------------------------	-------------------------	---	--

DNM. 1506..	ATKH-01-R ATKH-02-L	AKV-33-M6x22	AADN-3-0001	AAV-13-M5x8	AKY-01	AXR-01	2705-G1/8x5.5	AAL-03-3
--------------------	------------------------	--------------	-------------	-------------	--------	--------	---------------	----------

R: Derecha / Droite / Right L: Izquierda / Gauche / Left

● En Existencia / En stock / In Stock ○ Artículo sin Existencia / Indisponible en Stock / Non Stock Item

Ejemplo de Pedido / Exemple de Commande / Ordering Example

1 Piezas / pcs. / pcs. TCLNR 2020 K12-H

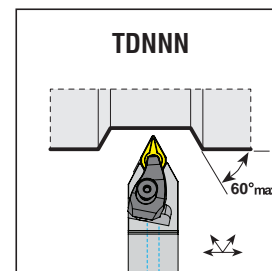
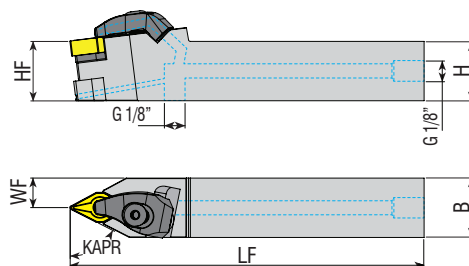

Código del Inserto Le Code de Commande Ordering Code	Stock		Dimension (mm) Dimension (mm)				Inserto Plaquette Insert	Abrazadera de Cuñas Mode de Fixation Wedge Clamp	Tornillo de Sujeción Vis de Fixation Wedge Screw	Cuñas Assise Shim	Tornillo de Placa Vis a Assise Shim Screw	Resorte Printemps Spring	Anillo Bague Ring	Pin de Roscado Tige Filetée Threaded Pin	Llaves Allen Clés Allen Allen Wrench
	Stock	Stock	HF=H	B	LF	WF									
TDNNN 2525 M15-H	●		25	25	150	32									

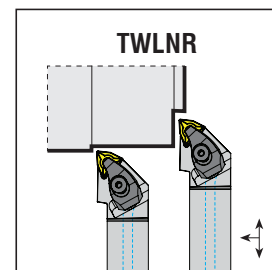
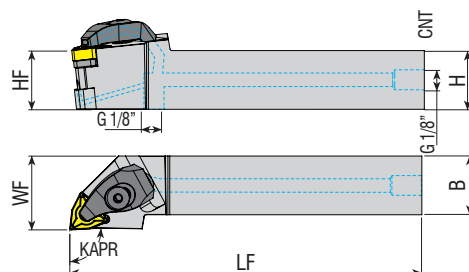

Código del Inserto Le Code de Commande Ordering Code	Stock		Dimension (mm) Dimension (mm)				Inserto Plaquette Insert	Abrazadera de Cuñas Mode de Fixation Wedge Clamp	Tornillo de Sujeción Vis de Fixation Wedge Screw	Cuñas Assise Shim	Tornillo de Placa Vis a Assise Shim Screw	Resorte Printemps Spring	Anillo Bague Ring	Pin de Roscado Tige Filetée Threaded Pin	Llaves Allen Clés Allen Allen Wrench
	R	L	HF=H	B	LF	WF									
TWLNR/L 2020 K08-H	●	●	20	20	125	25									
2525 M08-H	●	●	25	25	150	32									
3232 P08-H	●	●	32	32	170	40									

R: Derecha / Droite / Right L: Izquierda / Gauche / Left
 ● En Existencia / En stock / In Stock ○ Artículo sin Existencia / Indisponible en Stock / Non Stock Item

Ejemplo de Pedido / Exemple de Commande / Ordering Example
 1 Piezas / pcs. / pcs. TDNNN 2525 M15-H

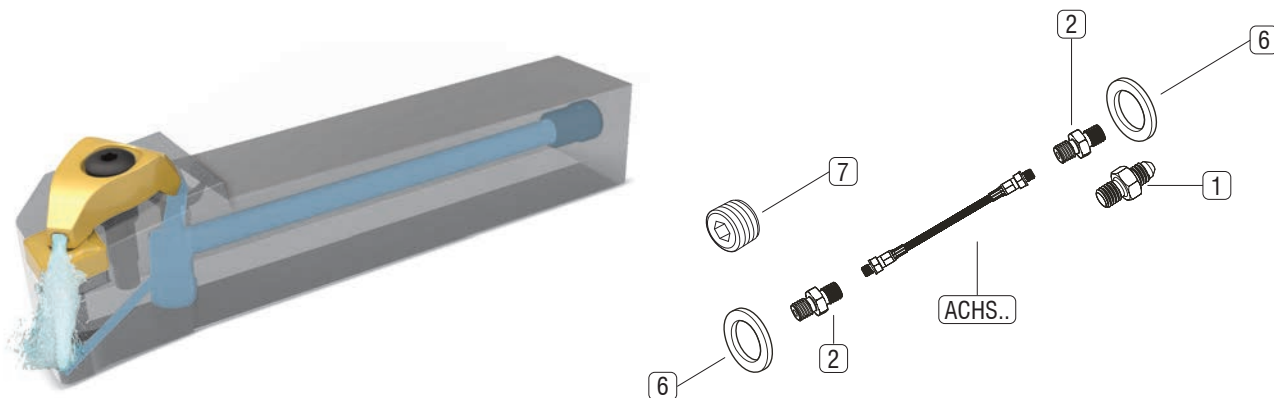

Nota: Se han diseñado 3 tipos de juegos de mangueras de refrigeración que se pueden utilizar en todos los tornos refrigerados internamente. Antes de usar las herramientas, se debe tener cuidado para asegurarse de que las conexiones no utilizadas estén cerradas con el tornillo en el juego y que el sellado esté asegurado. Los juegos de mangueras de refrigeración para herramientas de torno se pueden utilizar en el rango de presión de ACHS ... 10 bar hasta un máximo de 275 bar.

Note: 3 types d'ensembles de tuyaux de refroidissement sont conçus qui peuvent être utilisés dans tous les tours à refroidissement interne. Avant d'utiliser les outils, il faut veiller à ce que les connexions inutilisées sont fermées avec la vis dans l'ensemble et que l'étanchéité est assurée. ensembles de tuyaux de refroidissement pour tour d'outils peuvent être utilisés dans la plage de pression de CCSS ... 10 bar à la barre max 275.

Note: 3 types of cooling hose sets are designed that can be used in all internally cooled lathes. Before using the tools, care should be taken to ensure that the unused connections are closed with the screw in the set and that sealing is ensured. Cooling hose sets for lathe tools can be used in the pressure range of ACHS ... 10 bar to max 275 bar.

Partes En El Set Pièces Dans Le Jeu Parts In The Set				Código de Longitud / Code de Longueur / Length Code		
				Código del Set: Set Code: Set Code:	Código del Set: Set Code: Set Code:	Código del Set: Set Code: Set Code:
Imagen Image Picture	Código del Set Set Code Set Code	Descripción del Producto Description du Produit Product Description	ACHS-1-250	ACHS-2-250	ACHS-3-250	
1		Sujetador M10 M10 Fastener M10 Fastener	1x	-	-	
2		Cierre Doble G 1/8 " G 1/8" Double Fastener G 1/8" Double Fastener	2x	1x	-	
3		Angulo de Conexión G 1/8 " G 1/8" Connexion Angle G 1/8" Angle Connection	-	1x	2x	
4		Angulo de Conexión M10" M10" Connexion Angle M10" Angle Connection	-	1x	1x	
5		Pieza capilar G1 / 4 "-G1 / 8 " G1 / 4" -G1 / 8" Pièce Capillary G1 / 4"-G1/8" Capillary Piece	-	1x	1x	
6		Junta de Cobre Joint Cuivre Copper Gasket	2x	3x	4x	
7		Perno de sellado G1 / 8 " G1 / 8" D'étanchéité Boulon G1/8" Sealing Bolt	1x	1x	1x	
8		Manguera Tuyau Hose	1x	-	-	
9		Manguera Tuyau Hose	-	1x	-	
10		Manguera Tuyau Hose	-	-	1x	



konusulan
the spoken kalite...
quality...

M-SYSTEM

PORTA HERRAMIENTAS DE TORNEADO EXTERNO SISTEMA-M
PORTE-OUTILS POUR TOURNAGE EXTERIEUR SYSTÈME-M
M-SYSTEM EXTERNAL TURNING TOOLHOLDERS



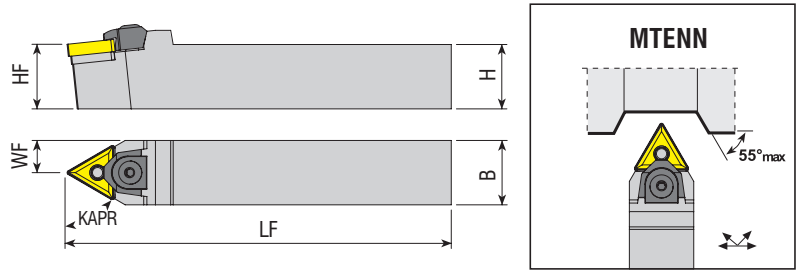

Código del Inserto Le Code de Commande Ordering Code	Stock		Dimension (mm) Dimension (mm)				Inserto Plaquette Insert	Abrazadera de Cuñas Mode de Fixation Wedge Clamp	Tornillo de Sujeción Vis de Fixation Wedge Screw	Cuñas Assise Shim	Pin Épingle Pin	Anillo Bague Ring	Arandela Timbre Washer	Llaves Allen Clés Allen Allen Wrench							
	R	L	HF=H	B	LF	WF															
MTENN 2020 K16	●		20	20	125	10															
2525 M16	●		25	25	150	12.5									TNM. 1604..	AMK-04	AATN-2-0002	APM-01			
3232 P16	●		32	32	170	16											AKV-30-M6x22				
2525 M22	●		25	25	150	12.5													AS-01	ABPL-01	AAL-03-3
3232 P22	●		32	32	170	16									TNM. 2204..	AMK-08	AATN-3-0015	APM-02			
4040 S22	●		40	40	250	20															

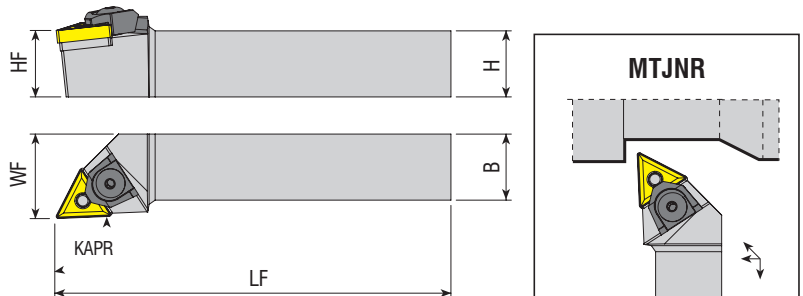

Código del Inserto Le Code de Commande Ordering Code	Stock		Dimension (mm) Dimension (mm)				Inserto Plaquette Insert	Abrazadera de Cuñas Mode de Fixation Wedge Clamp	Tornillo de Sujeción Vis de Fixation Wedge Screw	Cuñas Assise Shim	Pin Épingle Pin	Anillo Bague Ring	Arandela Timbre Washer	Llaves Allen Clés Allen Allen Wrench							
	R	L	HF=H	B	LF	WF															
MTJNR/L 2020 K16	●	●	20	20	125	25															
2525 M16	●	●	25	25	150	32									TNM. 1604..	AMK-04	AATN-2-0002	APM-01			
3232 P16	●	●	32	32	170	40											AKV-30-M6x22				
2525 M22	●	●	25	25	150	32													AS-01	ABPL-01	AAL-03-3
3232 P22	●	●	32	32	170	40									TNM. 2204..	AMK-08	AATN-3-0015	APM-02			
4040 S22	●	●	40	40	250	50															

R: Derecha / Droite / Right L: Izquierda / Gauche / Left

● En Existencia / En stock / In Stock ○ Artículo sin Existencia / Indisponible en Stock / Non Stock Item

Ejemplo de Pedido / Exemple de Commande / Ordering Example

1 Piezas / pcs. / pcs. MTENN 2020 K16

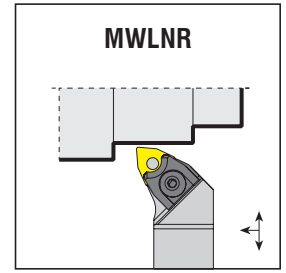
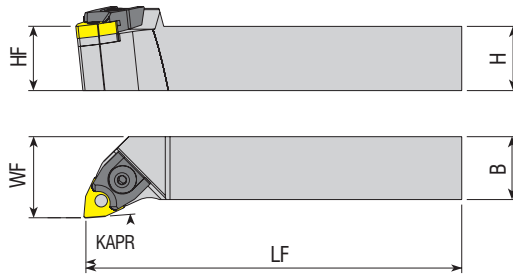

Código del Inserto Le Code de Commande Ordering Code	Stock Stock		Dimension (mm) Dimension (mm)				Inserto Plaquette Insert	Abrazadera de Cuñas Mode de Fixation Wedge Clamp	Tornillo de Sujeción Vis de Fixation Wedge Screw	Cuñas Assise Shim	Pin Épingle Pin	Anillo Bague Ring	Arandela Timbre Washer	Llaves Allen Clés Allen Allen Wrench
	R	L	HF=H	B	LF	WF								
MWLNR/L 1616 H06	●	●	16	16	100	20			-	APM-08	-	-	-	AAL-03-3
2020 K06	●	●	20	20	125	25								
2525 M06	●	●	25	25	150	32								
2020 K08	●	●	20	20	125	25			AAWN-3-0001	APM-02	AS-01	ABPL-01	AAL-03-3	
2525 M08	●	●	25	25	150	32								
3232 P08	●	●	32	32	170	40								

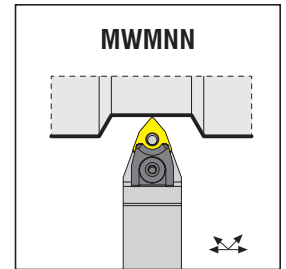
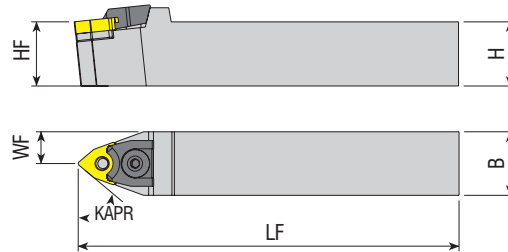

Código del Inserto Le Code de Commande Ordering Code	Stock Stock		Dimension (mm) Dimension (mm)				Inserto Plaquette Insert	Abrazadera de Cuñas Mode de Fixation Wedge Clamp	Tornillo de Sujeción Vis de Fixation Wedge Screw	Cuñas Assise Shim	Pin Épingle Pin	Anillo Bague Ring	Arandela Timbre Washer	Llaves Allen Clés Allen Allen Wrench
	R	L	HF=H	B	LF	WF								
MWMNN 1616 H06	●	●	16	16	100	8			-	APM-08	-	-	AAL-03-3	
2020 K06	●	●	20	20	125	10								
2525 M06	●	●	25	25	150	12.5								
2020 K08	●	●	20	20	125	10			AAWN-3-0001	APM-02	AS-01	ABPL-01	AAL-03-3	
2525 M08	●	●	25	25	150	12.5								
3232 P08	●	●	32	32	170	16								

R: Derecha / Droite / Right L: Izquierda / Gauche / Left

● En Existencia / En stock / In Stock ○ Artículo sin Existencia / Indisponible en Stock / Non Stock Item

Ejemplo de Pedido / Exemple de Commande / Ordering Example

1 Piezas / pcs. / pcs. MWLNR 1616 H06

P-SYSTEM

PORTA HERRAMIENTAS DE TORNEADO EXTERNO SISTEMA-P
PORTE-OUTILS POUR TOURNAGE EXTERIEUR SYSTEME-P
P-SYSTEM EXTERNAL TURNING TOOLHOLDERS

konusulan
the spoken kalite...
quality...



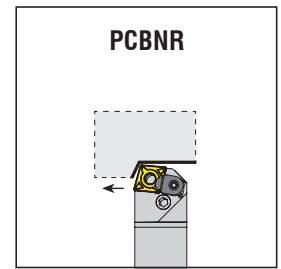
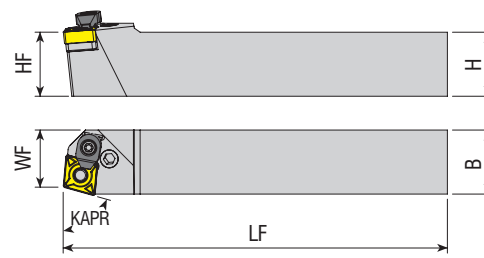

Código del Inserto
 Le Code de Commande
 Ordering Code

Stock Stock Stock		Dimension (mm) Dimension (mm) Dimension (mm)				Inserto Plaqueette Insert	Recambios / Pièces de Rechange / Spare Parts								
R	L	HF=H	B	LF	WF		Palanca Lever Lever	Tornillo de Palanca Lever Vis Lever Screw	Cuñas Assise Shim	Cuñas Resorte Ressort a Cale Shim Spring	Abrazadera de Cuñas Moue de Fixation Wedge Clamp	Tornillo de Sujeción Vis de Fixation Wedge Screw	Llaves Allen Cles Allen Allen Wrench		
PCBNR/L	2020 K12C	●	●	20	20	125	17.5	CNM. 1204..	APL-02	ALV-03-M8x19	AACN-3-0001	AAY-02	ACK-05	4015-M4x11	AAL-03-3
	2525 M12C	●	●	25	25	150	22.5								
	3232 P12C	●	●	32	32	170	29.5								
	2525 M16C	●	●	25	25	150	22	CNM. 1606..	APL-04	ALV-04-M8x22	AACN-3-0002	AAY-03			
	3232 P16C	●	●	32	32	170	27								
	3232 P19C	●	●	32	32	170	27	CNM. 1906..	APL-05	ALV-05-M10x27	AACN-3-0003	AAY-04	ACK-09	AAV-05-M6x15	AAL-05-4
	4040 S19C	●	●	40	40	250	37								
	4040 S25C	●	●	40	40	250	37	CNM. 2509..	APL-06	ALV-06-M12x36	AACN-3-0008	AAY-05	ACK-04	AKV-16-M6x16	AAL-07-5
	5050 S25C	○	○	50	50	250	47								

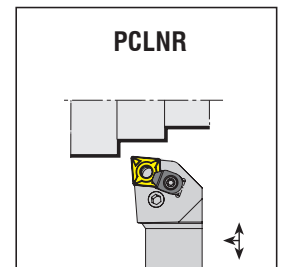
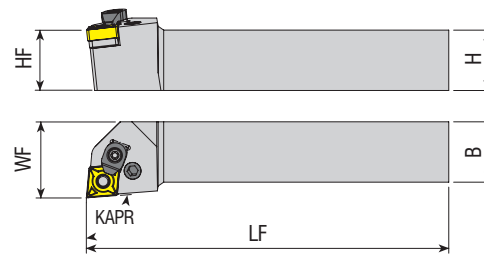

Código del Inserto
 Le Code de Commande
 Ordering Code

Stock Stock Stock		Dimension (mm) Dimension (mm) Dimension (mm)				Inserto Plaqueette Insert	Recambios / Pièces de Rechange / Spare Parts								
R	L	HF=H	B	LF	WF		Palanca Lever Lever	Tornillo de Palanca Lever Vis Lever Screw	Cuñas Assise Shim	Cuñas Resorte Ressort a Cale Shim Spring	Abrazadera de Cuñas Moue de Fixation Wedge Clamp	Tornillo de Sujeción Vis de Fixation Wedge Screw	Llaves Allen Cles Allen Allen Wrench		
PCLNR/L	1616 H09	●	●	16	16	100	20	CNM. 0903..	APL-01	ALV-02-M6x17	AACN-2-0002	AAY-01	-	-	AAL-02-2.5
	2020 K09	●	●	20	20	125	25								
	2525 M09	●	●	25	25	150	32								
	1616 H12	●	●	16	16	100	20	CNM. 1204..	APL-02	ALV-03-M8x19	AACN-3-0001	AAY-02	ACK-05	4015-M4x11	AAL-03-3
	2020 K12C	●	●	20	20	125	25								
	2525 M12C	●	●	25	25	150	32								
	3232 P12C	●	●	32	32	170	40	CNM. 1606..	APL-04	ALV-04-M8x22	AACN-3-0002	AAY-03			
	2525 M16C	●	●	25	25	150	32								
	3232 P16C	●	●	32	32	170	40	CNM. 1906..	APL-05	ALV-05-M10x27	AACN-3-0003	AAY-04	ACK-09	AAV-05-M6x15	AAL-05-4
	2525 M19C	●	●	25	25	150	32								
	3232 P19C	●	●	32	32	170	40	CNM. 2509..	APL-06	ALV-06-M12x36	AACN-3-0008	AAY-05	ACK-04	AKV-16-M6x16	AAL-07-5
	4040 S19C	●	●	40	40	250	50								
	4040 S25C	●	●	40	40	250	50								
	5050 S25C	●	●	50	50	250	60								

R: Derecha / Droite / Right L: Izquierda / Gauche / Left

● En Existencia / En stock / In Stock ○ Artículo sin Existencia / Indisponible en Stock / Non Stock Item

Ejemplo de Pedido / Exemple de Commande / Ordering Example

1 Piezas / pcs. / pcs. PCBNR 2020 K12C

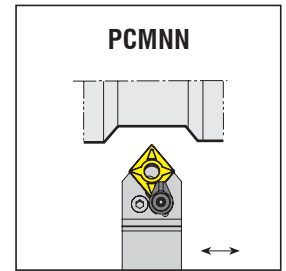
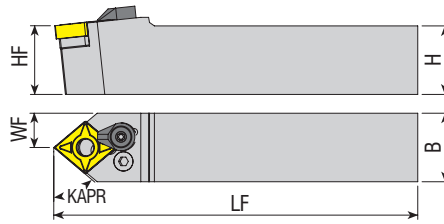

Código del Inserto Le Code de Commande Ordering Code	Stock Stock		Dimension (mm) Dimension (mm)				Inserto Plaquette Insert	Recambios / Pièces de Rechange / Spare Parts						
	R	L	HF=H	B	LF	WF		Palanca Lever	Tornillo de Palanca Lever Vis	Cuñas Assise Shim	Cuñas Resorte Ressort a Cale Shim Spring	Abrazadera de Cuñas Motte de Fixation Wedge Clamp	Tornillo de Sujeción Vis de Fixation Wedge Screw	Llaves Allen Clés Allen Allen Wrench
								APL-02	ALV-03-M8x19	AACN-3-0001	AAY-02	ACK-05	4015-M4x11	AAL-03-3
PCMN 2020 K12C	●		20	20	125	10	CNM. 1204..	APL-02	ALV-03-M8x19	AACN-3-0001	AAY-02	ACK-05	4015-M4x11	AAL-03-3
2525 M12C	●		25	25	150	12.5								
3232 P12C	○		32	32	170	16								
2525 M16C	○		25	25	150	12.5	CNM. 1606..	APL-04	ALV-04-M8x22	AACN-3-0002	AAY-03			
3232 P16C	○		32	32	170	16								
3232 P19C	●		32	32	170	16								
4040 S19C	●		40	40	250	20	CNM. 1906..	APL-05	ALV-05-M10x27	AACN-3-0003	AAY-04	ACK-09	AAV-05-M6x15	AAL-05-4
5050 S19C	○		50	50	250	25								
4040 S25C	●		40	40	250	20	CNM. 2509..	APL-06	ALV-06-M12x36	AACN-3-0008	AAY-05	ACK-04	AKV-16-M6x16	AAL-07-5

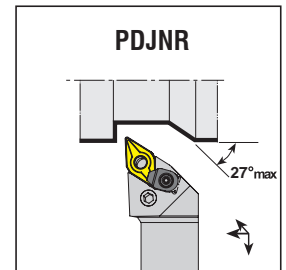
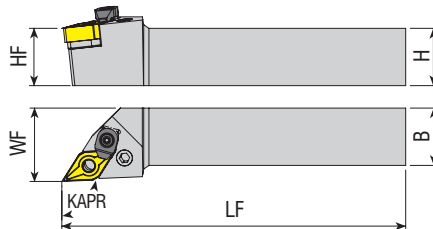

Código del Inserto Le Code de Commande Ordering Code	Stock Stock		Dimension (mm) Dimension (mm)				Inserto Plaquette Insert	Recambios / Pièces de Rechange / Spare Parts						
	R	L	HF=H	B	LF	WF		Palanca Lever	Tornillo de Palanca Lever Vis	Cuñas Assise Shim	Cuñas Resorte Ressort a Cale Shim Spring	Abrazadera de Cuñas Motte de Fixation Wedge Clamp	Tornillo de Sujeción Vis de Fixation Wedge Screw	Llaves Allen Clés Allen Allen Wrench
								APL-01	ALV-02-M6x17	AADN-SD317	AAY-01	-	-	AAL-02-2.5
PDJNR/L 1616 H11	●	●	16	16	100	20	DNM. 1104..	APL-01	ALV-02-M6x17	AADN-SD317	AAY-01	-	-	AAL-02-2.5
2020 K11	●	●	20	20	125	25								
2525 M11	●	●	25	25	150	32								
2020 K15C	●	●	20	20	125	25	DNM. 1506..	APL-03	ALV-03-M8x19	AADN-3-0001	AAY-02	ACK-05	4015-M4x11	AAL-03-3
2525 M15C	●	●	25	25	150	32								
3232 P15C	●	●	32	32	170	40								
4040 S15C	●	●	40	40	250	50								

R: Derecha / Droite / Right L: Izquierda / Gauche / Left

● En Existencia / En stock // In Stock ○ Artículo sin Existencia / Indisponible en Stock / Non Stock Item

Ejemplo de Pedido / Exemple de Commande / Ordering Example

1 Piezas / pcs. / pcs. PCMN 2020 K12C

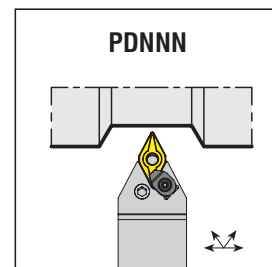
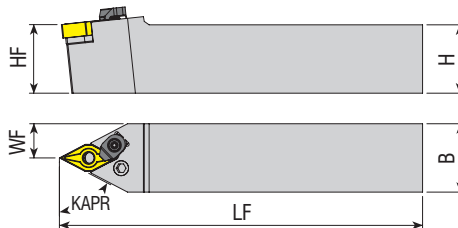

Código del Inserto Le Code de Commande Ordering Code	Stock Stock		Dimension (mm) Dimension (mm) Dimension (mm)				Inserto Plaqueette Insert	Recambios / Pièces de Rechange / Spare Parts						
	R	L	HF=H	B	LF	WF		Palanca Lever	Tornillo de Palanca Lever Vis	Cuñas Assise Shim	Cuñas Resorte Ressort a Cale Shim Spring	Abrazadera de Cuñas Motte de Fixation Wedge Clamp	Tornillo de Sujeción Vis de Fixation Wedge Screw	Llaves Allen Clés Allen Allen Wrench
PDNNN 1616 H11	●		16	16	100	8						-	-	AAL-02-2.5
2020 K11	●		20	20	125	10								
2525 M11	●		25	25	150	12.5								
2020 K15C	●		20	20	125	10						ACK-05	4015-M4x11	AAL-03-3
2525 M15C	●		25	25	150	12.5								
3232 P15C	●		32	32	170	16								

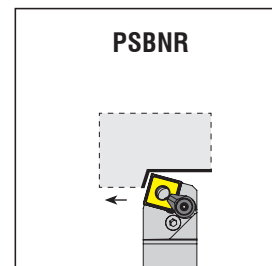
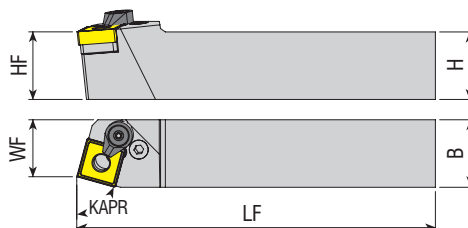

Código del Inserto Le Code de Commande Ordering Code	Stock Stock		Dimension (mm) Dimension (mm) Dimension (mm)				Inserto Plaqueette Insert	Recambios / Pièces de Rechange / Spare Parts						
	R	L	HF=H	B	LF	WF		Palanca Lever	Tornillo de Palanca Lever Vis	Cuñas Assise Shim	Cuñas Resorte Ressort a Cale Shim Spring	Abrazadera de Cuñas Motte de Fixation Wedge Clamp	Tornillo de Sujeción Vis de Fixation Wedge Screw	Llaves Allen Clés Allen Allen Wrench
PSBNNR/L 1616 H09	●	●	16	16	100	13						-	-	AAL-02-2.5
2020 K09	○	○	20	20	125	17								
2020 K12	●	●	20	20	125	17								
2525 M12C	●	●	25	25	150	22						ACK-05	4015-M4x11	AAL-03-3
3232 P12C	●	●	32	32	170	27								
2525 M15	●	●	25	25	150	22						-	-	-
3232 P15C	●	●	32	32	170	27								
3232 P19C	●	●	32	32	170	27						ACK-09	AAV-05-M6x15	AAL-05-4
4040 S19C	●	●	40	40	250	35								
4040 S25C	●	●	40	40	250	35						ACK-04	AKV-16-M6x16	AAL-07-5
5050 S25C	●	○	50	50	250	43								

R: Derecha / Droite / Right L: Izquierda / Gauche / Left
 ● En Existencia / En stock / In Stock ○ Artículo sin Existencia / Indisponible en Stock / Non Stock Item

Ejemplo de Pedido / Exemple de Commande / Ordering Example
 1 Piezas / pcs. / pcs. PDNNN 1616 H11

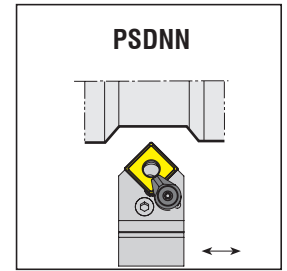
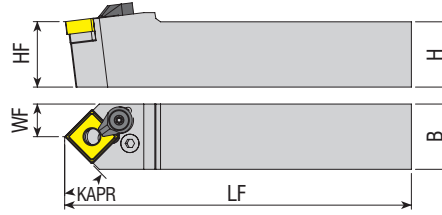

Código del Inserto Le Code de Commande Ordering Code	Stock Stock	Dimension (mm) Dimension (mm) Dimension (mm)				Inserto Plaquette Insert	Recambios / Pièces de Rechange / Spare Parts						
		HF=H	B	LF	WF		Palanca Lever Lever	Tornillo de Palanca Lever Vis Lever Screw	Cuñas Assise Shim	Cuñas Resorte Resort a Cale Shim Spring	Abrazadera de Cuñas Wedge Clamp	Tornillo de Sujeción Vis de Fixation Wedge Screw	Llaves Allen Clés Allen Allen Wrench
PSDNN 1616 H09	●	16	16	100	8						-	-	
2020 K12C	●	20	20	125	10	SNM. 1204..							
2525 M12C	●	25	25	150	12.5								
3232 P12C	●	32	32	170	16								
2020 K15	●	20	20	125	10	SNM. 1506..					-	-	
2525 M15C	●	25	25	150	12.5								
3232 P19C	●	32	32	170	16								
4040 S19C	○	40	40	250	20	SNM. 1906..							
5050 S19C	○	50	50	250	25								
4040 S25C	●	40	40	250	20	SNM. 2509..							
5050 S25C	○	50	50	250	25								

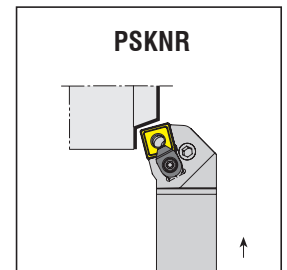
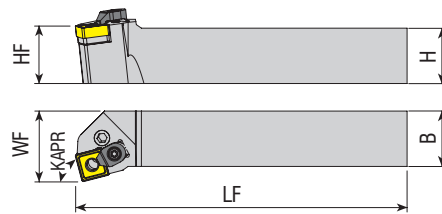

Código del Inserto Le Code de Commande Ordering Code	Stock Stock		Dimension (mm) Dimension (mm) Dimension (mm)				Inserto Plaquette Insert	Recambios / Pièces de Rechange / Spare Parts						
	R	L	HF=H	B	LF	WF		Palanca Lever Lever	Tornillo de Palanca Lever Vis Lever Screw	Cuñas Assise Shim	Cuñas Resorte Resort a Cale Shim Spring	Abrazadera de Cuñas Wedge Clamp	Tornillo de Sujeción Vis de Fixation Wedge Screw	Llaves Allen Clés Allen Allen Wrench
PSKNR/L 2020 K09	●	○	20	20	125	25						-	-	
2020 K12C	●	●	20	20	125	25	SNM. 1204..							
2525 M12C	●	●	25	25	150	32								
3232 P12C	●	●	32	32	170	40								
2525 M15C	●	●	25	25	150	32	SNM. 1506..							
3232 P15C	●	●	32	32	170	40								
3232 P19C	●	●	32	32	170	40								
4040 S19C	●	●	40	40	250	50	SNM. 1906..							
4040 S25C	●	●	40	40	250	50								
5050 S25C	●	○	50	50	250	60	SNM. 2509..							

R: Derecha / Droite / Right L: Izquierda / Gauche / Left

● En Existencia / En stock / In Stock ○ Artículo sin Existencia / Indisponible en Stock / Non Stock Item

Ejemplo de Pedido / Exemple de Commande / Ordering Example

1 Piezas / pcs. / pcs. PSDNN 1616 H09

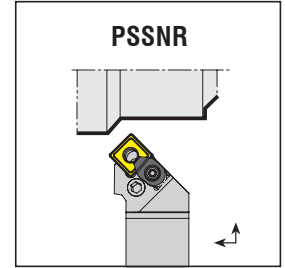
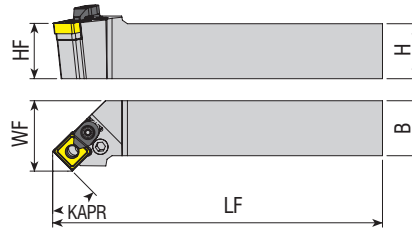

Código del Inserto Le Code de Commande Ordering Code		Stock Stock		Dimension (mm) Dimension (mm)			Inserto Plaquette Insert	Recambios / Pièces de Rechange / Spare Parts							
		R	L	HF=H	B	LF		WF	Palanca Lever Lever	Tornillo de Palanca Lever Vis Lever Screw	Cuñas Assise Shim	Cuñas Resorte Ressort à Cale Shim Spring	Abrazadera de Cuñas Mode de Fixation Wedge Clamp	Tornillo de Sujeción Vis de Fixation Wedge Screw	Llaves Allen Clés Allen Allen Wrench
PSSNR/L 1616 H09	2020 K09	●	○	16	16	100	20	SNM. 0903..	APL-01	ALV-02-M6x17	AASN-2-0002	AAY-01	-	-	AAL-02-2.5
	2020 K12C	●	●	20	20	125	25								
2525 M12C	3232 P12C	●	●	25	25	150	32	SNM. 1204..	APL-02	ALV-03-M8x19	AASN-3-0004	AAY-02	ACK-05	4015-M4x11	AAL-03-3
	3232 P15C	●	○	32	32	170	40								
3232 P19C	4040 S19C	●	●	32	32	170	40	SNM. 1506..	APL-04	ALV-04-M8x22	AASN-3-0023	AAY-03	-	-	-
	4040 S25C	●	●	40	40	250	50								
4040 S19C	4040 S25C	●	●	40	40	250	50	SNM. 1906..	APL-05	ALV-05-M10x27	AASN-3-0005	AAY-04	ACK-09	AAV-05-M6x15	AAL-05-4
	4040 S25C	●	●	40	40	250	50								
4040 S25C	4040 S25C	●	●	40	40	250	50	SNM. 2509..	APL-06	ALV-06-M12x36	AASN-3-0020	AAY-05	ACK-04	AKV-16-M6x16	AAL-07-5

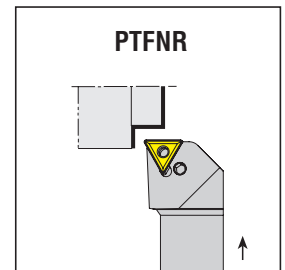
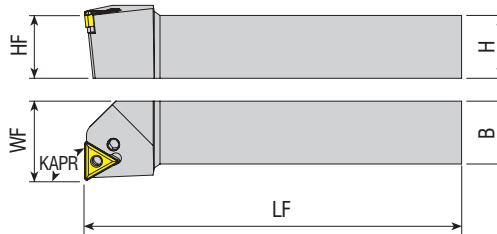

Código del Inserto Le Code de Commande Ordering Code		Stock Stock		Dimension (mm) Dimension (mm)			Inserto Plaquette Insert	Recambios / Pièces de Rechange / Spare Parts							
		R	L	HF=H	B	LF		WF	Palanca Lever Lever	Tornillo de Palanca Lever Vis Lever Screw	Cuñas Assise Shim	Cuñas Resorte Ressort à Cale Shim Spring	Abrazadera de Cuñas Mode de Fixation Wedge Clamp	Tornillo de Sujeción Vis de Fixation Wedge Screw	Llaves Allen Clés Allen Allen Wrench
PTFNR/L 1616 H16	2020 K16	●	●	16	16	100	20	TNM. 1604..	APL-01	ALV-02-M6x17	AATN-3-0025	AAY-01	-	-	AAL-02-2.5
	2525 M16	●	●	20	20	125	25								
2525 M16	3232 P16	●	●	25	25	150	32	TNM. 2204..	APL-02	ALV-03-M8x19	AATN-3-0015	AAY-02	ACK-05	4015-M4x11	AAL-03-3
	3232 P22C	●	●	25	25	150	32								
3232 P22C	4040 S27C	○	○	32	32	170	40	TNM. 2706..	APL-05	ALV-05-M10x27	07042701	AAY-04	ACK-09	AAV-05-M6x15	AAL-05-4
	4040 S27C	○	○	40	40	250	50								

R: Derecha / Droite / Right L: Izquierda / Gauche / Left

● En Existencia / En stock / In Stock ○ Artículo sin Existencia / Indisponible en Stock / Non Stock Item

Ejemplo de Pedido / Exemple de Commande / Ordering Example

1 Piezas / pcs. / pcs. PSSNR 1616 H09

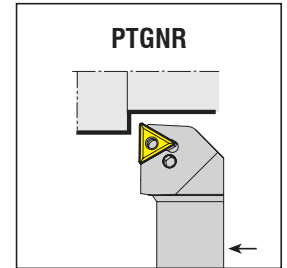
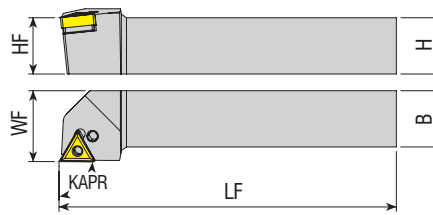

Código del Inserto Le Code de Commande Ordering Code	Stock		Dimension (mm) Dimension (mm)				Inserto Plaquette Insert	Recambios / Pièces de Rechange / Spare Parts						
	R	L	HF=H	B	LF	WF		Palanca Lever	Tornillo de Palanca Lever Vis	Cuñas Assise Shim	Cuñas Resorte Ressort a Cale Shim Spring	Abrazadera de Cuñas Motte de Fixation Wedge Clamp	Tornillo de Sujeción Vis de Fixation Wedge Screw	Llaves Allen Clés Allen Allen Wrench
	○	○												
PTGNR/L 1010 E11	○	○	10	10	70	12	TNM. 1103..	APL-11	ALV-10-M5x10	-	-	-	-	AAL-13-2.5
1212 F11	○	○	12	12	80	16								
1616 H11	○	○	16	16	100	20								
1616 H16	●	●	16	16	100	20	TNM. 1604..	APL-01	ALV-02-M6x17	AATN-3-0025	AAY-01	-	-	AAL-02-2.5
2020 K16	●	●	20	20	125	25								
2525 M16	●	●	25	25	150	32								
3232 P16	○	○	32	32	170	40	TNM. 2204..	APL-02	ALV-03-M8x19	AATN-3-0015	AAY-02	ACK-05	4015-M4x11	AAL-03-3
2525 M22C	●	●	25	25	150	32								
3232 P22C	●	●	32	32	170	40								
4040 S27C	○	○	40	40	250	50	TNM. 2706..	APL-05	ALV-05-M10x27	07042701	AAY-04	ACK-09	AAV-05-M6x15	AAL-05-4

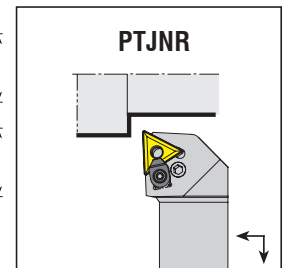
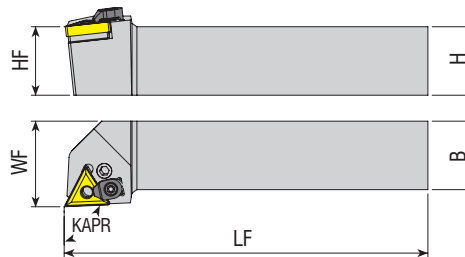

Código del Inserto Le Code de Commande Ordering Code	Stock		Dimension (mm) Dimension (mm)				Inserto Plaquette Insert	Recambios / Pièces de Rechange / Spare Parts						
	R	L	HF=H	B	LF	WF		Palanca Lever	Tornillo de Palanca Lever Vis	Cuñas Assise Shim	Cuñas Resorte Ressort a Cale Shim Spring	Abrazadera de Cuñas Motte de Fixation Wedge Clamp	Tornillo de Sujeción Vis de Fixation Wedge Screw	Llaves Allen Clés Allen Allen Wrench
	○	○												
PTJNR/L 1010 E11	○	○	10	10	70	12	TNM. 1103..	APL-11	ALV-10-M5x10	-	-	-	-	AAL-13-2.5
1212 F11	○	○	12	12	80	16								
1616 H11	○	○	16	16	100	20								
1616 H16	●	●	16	16	100	20	TNM. 1604..	APL-01	ALV-02-M6x17	AATN-3-0025	AAY-01	-	-	AAL-02-2.5
2020 K16	●	●	20	20	125	25								
2525 M16	●	●	25	25	150	32								
3232 P16	●	●	32	32	170	40	TNM. 2204..	APL-02	ALV-03-M8x19	AATN-3-0015	AAY-02	ACK-05	4015-M4x11	AAL-03-3
2525 M22C	●	●	25	25	150	32								
3232 P22C	●	●	32	32	170	40								
4040 S27C	○	○	40	40	250	50	TNM. 2706..	APL-05	ALV-05-M10x27	07042701	AAY-04	ACK-09	AAV-05-M6x15	AAL-05-4

R: Derecha / Droite / Right L: Izquierda / Gauche / Left

● En Existencia / En stock / In Stock ○ Artículo sin Existencia / Indisponible en Stock / Non Stock Item

Ejemplo de Pedido / Exemple de Commande / Ordering Example

1 Piezas / pcs. / pcs.PTGNR 1010 E11

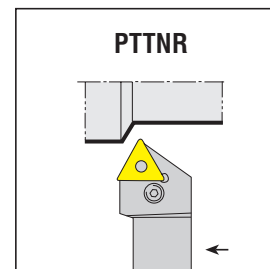
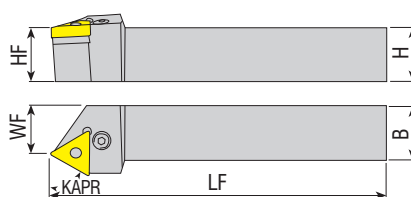

Código del Inserto Le Code de Commande Ordering Code	Dimension (mm) Dimension (mm)						Inserto Plaqueette Insert	Recambios / Pièces de Rechange / Spare Parts						
	Stock Stock		HF=H	B	LF	WF		Palanca Lever	Tornillo de Palanca Lever Vis	Cuñas Assise Shim	Cuñas Resorte Ressort à Cale Shim Spring	Abrazadera de Cuñas Mode de Fixation Wedge Clamp	Tornillo de Sujeción Vis de Fixation Wedge Screw	Llaves Allen Clés Allen Allen Wrench
	R	L												
PTTNR/L 1616 H16	●	●	16	16	100	13	TNM. 1604..					-	-	AAL-02-2.5
2020 K16	●	●	20	20	125	17								
2525 M16	●	●	25	25	150	21.5								
3232 P16	●	●	32	32	170	31								
2525 M22C	●	●	25	25	150	20.5	TNM. 2204..					ACK-05	4015-M4x11	AAL-03-3
3232 P22C	●	●	32	32	170	29								

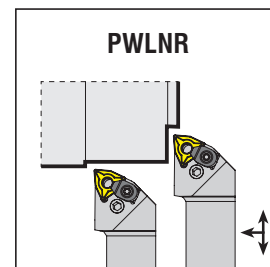
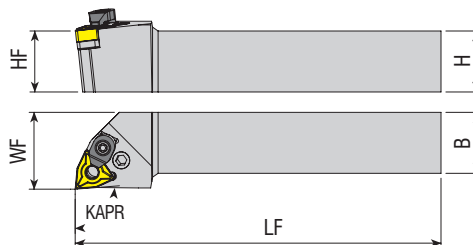

Código del Inserto Le Code de Commande Ordering Code	Dimension (mm) Dimension (mm)						Inserto Plaqueette Insert	Recambios / Pièces de Rechange / Spare Parts						
	Stock Stock		HF=H	B	LF	WF		Palanca Lever	Tornillo de Palanca Lever Vis	Cuñas Assise Shim	Cuñas Resorte Ressort à Cale Shim Spring	Abrazadera de Cuñas Mode de Fixation Wedge Clamp	Tornillo de Sujeción Vis de Fixation Wedge Screw	Llaves Allen Clés Allen Allen Wrench
	R	L												
PWLNR/L 1616 H06	●	●	16	16	100	20	WNM. 0604..					-	-	AAL-02-2.5
2020 K06	●	●	20	20	125	25								
2525 M06	●	●	25	25	150	32								
3232 P06	○	○	32	32	170	40								
1616 H08	●	●	16	16	100	20	WNM. 0804..					ACK-05	4015-M4x11	AAL-03-3
2020 K08C	●	●	20	20	125	25								
2525 M08C	●	●	25	25	150	32								
3232 P08C	●	●	32	32	170	40								

R: Derecha / Droite / Right L: Izquierda / Gauche / Left
 ● En Existencia / En stock / In Stock ○ Artículo sin Existencia / Indisponible en Stock / Non Stock Item

Ejemplo de Pedido / Exemple de Commande / Ordering Example
 1 Piezas / pcs. / pcs. PTTNR 1616 H16

P-SYSTEM

**SISTEMA P PORTA HERRAMIENTAS DE TORNEADO EXTERNO
CON AGUJERO REFRIGERANTE**

*SYSTÈME-P PORTE-OUTILS AVEC TROU D'AROSAGE TOURNAGE EXTERIEUR
P-SYSTEM EXTERNAL TURNING TOOLHOLDERS WITH COOLANT HOLE*

*konusulan
the spoken kalite...
quality...*



ESCANEAR PARA MAS MÁS DETALLES
SCAN ME POUR PLUS DE DÉTAILS
SCAN ME FOR MORE DETAILS

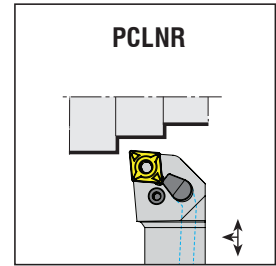
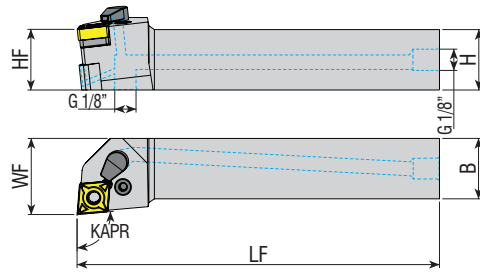
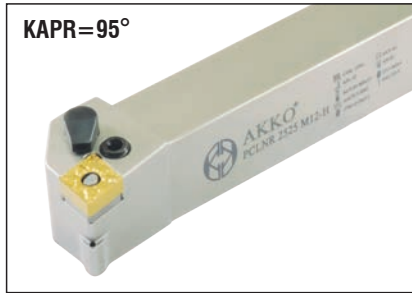

Código del Inserto Le Code de Commande Ordering Code	Stock Stock		Dimension (mm) Dimension (mm)				Recambios / Pièces de Rechange / Spare Parts																	
	R	L	HF=H	B	LF	WF	Inserto Plaque Insert	Palanca Lever	Tornillo de Palanca Lever Screw	Cuñas Assise Shim	Cuñas Resorte Resort a Cale Shim Spring	Anillo Bague Ring	Pin de Roscado Tige Fileté Threaded Pin	Boquilla Buse Nozzle	Llaves Allen Clés Allen Allen Wrench									
	●	○																						
PCLNR/L 2020 K12-H	●	●	20	20	125	25	CNM. 1204..																	
2525 M12-H	●	●	25	25	150	32											APL-02	ALV-03-M8x19	AACN-3-0001	AAY-02	AXR-01 AOR-01	2705-G1/8x5.5	AN-01	AAL-03-3
3232 P12-H	●	○	32	32	170	40																		

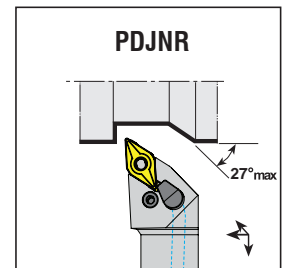
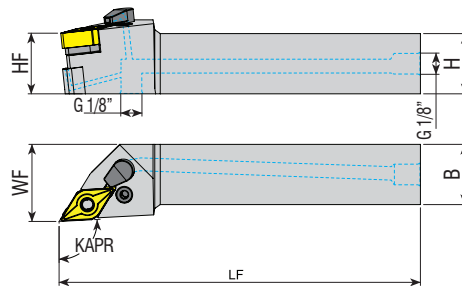

Código del Inserto Le Code de Commande Ordering Code	Stock Stock		Dimension (mm) Dimension (mm)				Recambios / Pièces de Rechange / Spare Parts																	
	R	L	HF=H	B	LF	WF	Inserto Plaque Insert	Palanca Lever	Tornillo de Palanca Lever Screw	Cuñas Assise Shim	Cuñas Resorte Resort a Cale Shim Spring	Anillo Bague Ring	Pin de Roscado Tige Fileté Threaded Pin	Boquilla Buse Nozzle	Llaves Allen Clés Allen Allen Wrench									
	●	○																						
PDJNR/L 2020 K15-H	●	●	20	20	125	25	DNM. 1506..																	
2525 M15-H	●	●	25	25	150	32											APL-03	ALV-03-M8x19	AADN-3-0001	AAY-02	AXR-01 AOR-01	2705-G1/8x5.5	AN-01	AAL-03-3
3232 P15-H	●	○	32	32	170	40																		

R: Derecha / Droite / Right L: Izquierda / Gauche / Left

● En Existencia / En stock / In Stock ○ Artículo sin Existencia / Indisponible en Stock / Non Stock Item

Ejemplo de Pedido / Exemple de Commande / Ordering Example

1 Piezas / pcs. / pcs. PCLNR 2020 K12-H





KAPR=62.5°

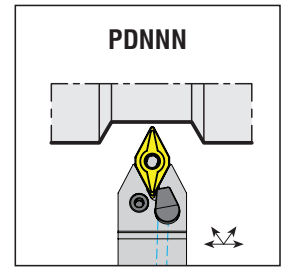
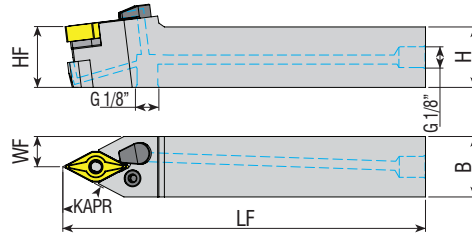

Código del Inserto
 Le Code de Commande
 Ordering Code

Código del Inserto Le Code de Commande Ordering Code	Stock Stock		Dimension (mm) Dimension (mm) Dimension (mm)				Inserto Plaque Insert	Palanca Lever Lever	Tornillo de Palanca Lever Vis Lever Screw	Cuñas Assise Shim	Cuñas Resorte Ressort a Cale Shim Spring	Anillo Bague Ring	Pin de Roscado Tige Filetée Threaded Pin	Boquilla Buse Nozzle	Llaves Allen Clés Allen Allen Wrench
	R	L	HF=H	B	LF	WF									
PDNNN 2525 M15-H	●		25	25	150	32									
							DNM. 1506..	APL-03	ALV-03-M8x19	AADN-3-0001	AAY-02	AXR-01 AOR-01	2705-G1/8x5.5	AN-01	AAL-03-3



KAPR=95°

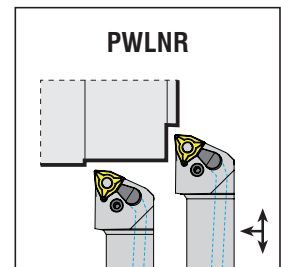
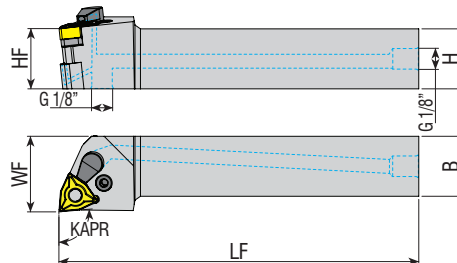

Código del Inserto
 Le Code de Commande
 Ordering Code

Código del Inserto Le Code de Commande Ordering Code	Stock Stock		Dimension (mm) Dimension (mm) Dimension (mm)				Inserto Plaque Insert	Palanca Lever Lever	Tornillo de Palanca Lever Vis Lever Screw	Cuñas Assise Shim	Cuñas Resorte Ressort a Cale Shim Spring	Anillo Bague Ring	Pin de Roscado Tige Filetée Threaded Pin	Boquilla Buse Nozzle	Llaves Allen Clés Allen Allen Wrench
	R	L	HF=H	B	LF	WF									
PWLNR/L 2020 K08-H	●	●	20	20	125	25									
2525 M08-H	●	●	25	25	150	32	WNM. 0804..	APL-02	ALV-03-M8x19	AADN-3-0001	AAY-02	AXR-01 AOR-01	2705-G1/8x5.5	AN-01	AAL-03-3

R: Derecha / Droite / Right L: Izquierda / Gauche / Left

● En Existencia / En stock / In Stock ○ Artículo sin Existencia / Indisponible en Stock / Non Stock Item

Ejemplo de Pedido / Exemple de Commande / Ordering Example

1 Piezas / pcs. / pcs. PDNNN 2525 M15-H

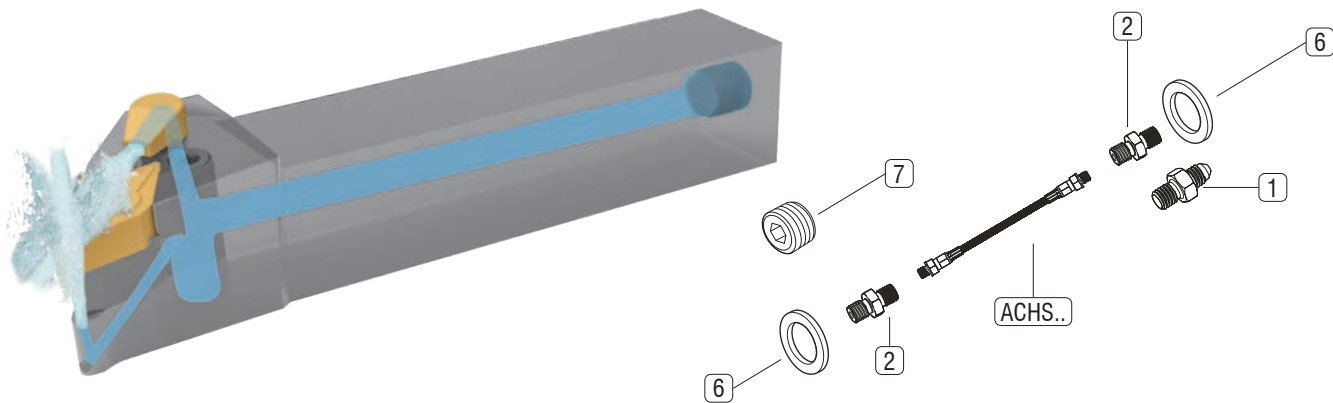

Nota: Se han diseñado 3 tipos de juegos de mangueras de refrigeración que se pueden utilizar en todos los tornos refrigerados internamente. Antes de usar las herramientas, se debe tener cuidado para asegurarse de que las conexiones no utilizadas estén cerradas con el tornillo en el juego y que el sellado esté asegurado. Los juegos de mangueras de refrigeración para herramientas de torno se pueden utilizar en el rango de presión de ACHS ... 10 bar hasta un máximo de 275 bar.

Note: 3 types d'ensembles de tuyaux de refroidissement sont conçus qui peuvent être utilisés dans tous les tours à refroidissement interne. Avant d'utiliser les outils, il faut veiller à ce que les connexions inutilisées sont fermées avec la vis dans l'ensemble et que l'étanchéité est assurée. Ensembles de tuyaux de refroidissement pour tour d'outils peuvent être utilisés dans la plage de pression de CCSS ... 10 bar à la barre max 275.

Note: 3 types of cooling hose sets are designed that can be used in all internally cooled lathes. Before using the tools, care should be taken to ensure that the unused connections are closed with the screw in the set and that sealing is ensured. Cooling hose sets for lathe tools can be used in the pressure range of ACHS ... 10 bar to max 275 bar.

Partes En El Set
Pièces Dans Le Jeu
Parts In The Set

Código de Longitud / Code de Longueur / Length Code

	Imagen Image Picture	Código del Set Code de l'ensemble Set Code	Descripción del Producto Description du Produit Product Description	Código de Longitud / Code de Longueur / Length Code		
				Código del Set: Code de l'ensemble: Set Code: ACHS-1-250	Código del Set: Code de l'ensemble: Set Code: ACHS-2-250	Código del Set: Code de l'ensemble: Set Code: ACHS-3-250
1		AMP-01	Sujetador M10 M10 Fastener M10 Fastener	1x	-	-
2		AMP-02	Cierre Doble G 1/8 " G 1/8" Double Fastener G 1/8" Double Fastener	2x	1x	-
3		AMP-03	Angulo de Conexión G 1/8 " G 1/8" Connexion Angle G 1/8" Angle Connection	-	1x	2x
4		AMP-04	Angulo de Conexión M10" M10" Connexion Angle M10" Angle Connection	-	1x	1x
5		AMP-05	Pieza capilar G1 / 4 "-G1 / 8 " G1 / 4" -G1 / 8" Pièce Capillary G1 / 4"-G1/8" Capillary Piece	-	1x	1x
6		AG-01	Junta de Cobre Joint Cuivre Copper Gasket	2x	3x	4x
7		2705-G1/8-5.5	Perno de sellado G1 / 8 " G1 / 8" D'étanchéité Boulon G1/8" Sealing Bolt	1x	1x	1x
8		AH-1-250	Manguera Tuyau Hose	1x	-	-
9		AH-2-250	Manguera Tuyau Hose	-	1x	-
10		AH-3-250	Manguera Tuyau Hose	-	-	1x

C-SYSTEM

PORTA HERRAMIENTAS DE TORNEADO EXTERNO SISTEMA-C
PORTE-OUTILS POUR TOURNAGE EXTERIEUR SYSTÈME-C
C-SYSTEM EXTERNAL TURNING TOOLHOLDERS

konusulan
the spoken kalite...
quality...



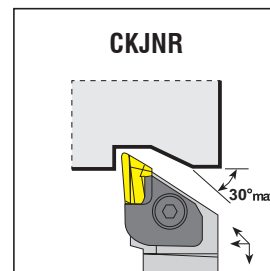
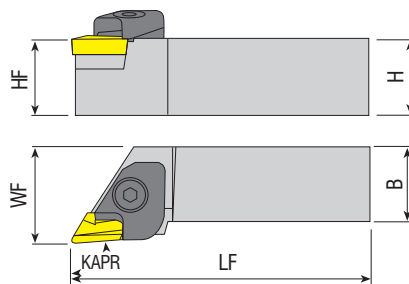

Código del Inserto
Le Code de Commande
Ordering Code

Stock
 Stock
 Stock

Dimension (mm)
 Dimension (mm)
 Dimension (mm)

Inserto
 Plaquette
 Insert

Abrazadera de Cuñas
 Mode de Fixation
 Wedge Clamp

Tornillo de Sujeción
 Vis de Fixation
 Wedge Screw

Cuñas
 Assise
 Shim

Tornillo de Placa
 Vis a Assise
 Shim Screw

Resorte
 Printemps
 Spring

Arandela
 Timbre
 Washer

Llaves Allen
 Cies Allen
 Allen Wrench

Recambios / Pièces de Rechange / Spare Parts

Código del Inserto Le Code de Commande Ordering Code	Stock Stock Stock		Dimension (mm) Dimension (mm) Dimension (mm)				Inserto Plaquette Insert	Abrazadera de Cuñas Mode de Fixation Wedge Clamp	Tornillo de Sujeción Vis de Fixation Wedge Screw	Cuñas Assise Shim	Tornillo de Placa Vis a Assise Shim Screw	Resorte Printemps Spring	Arandela Timbre Washer	Llaves Allen Cies Allen Allen Wrench							
	R	L	HF=H	B	LF	WF															
CKJNR/L 2020 K16	●	●	20	20	125	27.5	KNUX 1604..														
2525 M16	●	●	25	25	150	31.5									ACK-01-R	AKV-06-M6x20	AKS-16-R	AAV-01-M3x10	AKY-02	ABPL-01	AAL-05-4
3232 P16	●	●	32	32	170	40									ACK-02-L		AKS-16-L				
4040 S16	●	●	40	40	250	50															

R: Derecha / Droite / Right L: Izquierda / Gauche / Left

● En Existencia / En stock / In Stock ○ Artículo sin Existencia / Indisponible en Stock / Non Stock Item

Ejemplo de Pedido / Exemple de Commande / Ordering Example

1 Piezas / pcs. / pcs. CKJNR 2020 K16



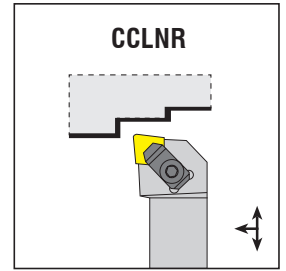
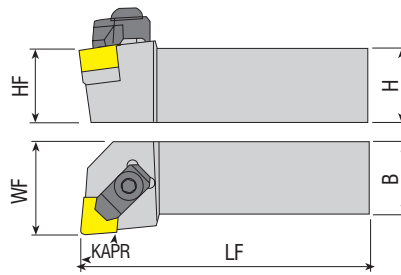

Código del Inserto Le Code de Commande Ordering Code	Stock		Dimension (mm) Dimension (mm)				Inserto Plaquette Insert	Recambios / Pièces de Rechange / Spare Parts					
	R	L	HF=H	B	LF	WF		Abrazadera de Cuñas Mode de Fixation Wedge Clamp	Tornillo de Sujeción Vis de Fixation Wedge Screw	Cuñas Assise Shim	Tornillo de Placa Vis a Assise Shim Screw	Anillo Bague Ring	Llaves Allen Clés Allen Allen Wrench
CCLNR/L 2525 M1207C	●	●	25	25	150	32	CN.N 1207..	ACK-13	AKV-11-M8x29	AACN-3-0001	AAV-02-M5x12	ACS-01	AAL-05-4
3232 P1207C	●	●	32	32	170	40							
2525 M1607C	●	●	25	25	150	32							
							CN.N 1607..	ACK-13	AKV-11-M8x29	AACN-3-0002	AAV-05-M6x15	ACS-01	AAL-05-4

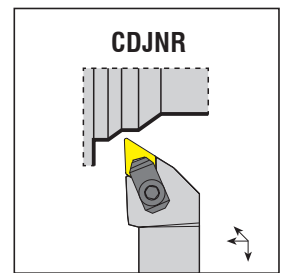
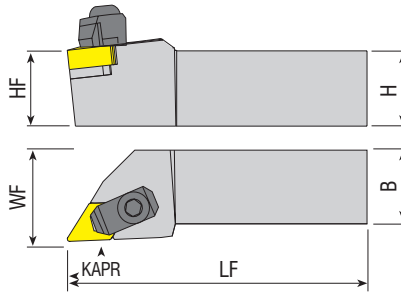

Código del Inserto Le Code de Commande Ordering Code	Stock		Dimension (mm) Dimension (mm)				Inserto Plaquette Insert	Recambios / Pièces de Rechange / Spare Parts					
	R	L	HF=H	B	LF	WF		Abrazadera de Cuñas Mode de Fixation Wedge Clamp	Tornillo de Sujeción Vis de Fixation Wedge Screw	Cuñas Assise Shim	Tornillo de Placa Vis a Assise Shim Screw	Anillo Bague Ring	Llaves Allen Clés Allen Allen Wrench
CDJNR/L 2525 M1107C	●	●	25	25	150	32	DN.N 1107..	ACK-22	AKV-11-M8x29	AADN-2-0001	AAV-04-M5x12	ACS-01	AAL-05-4
2525 M1507C	●	●	25	25	150	32							
3232 P1507C	●	●	32	32	170	40							
							DN.N 1507..	ACK-13	AKV-11-M8x29	AADN-3-0001	AAV-02-M5x12	ACS-01	AAL-05-4

R: Derecha / Droite / Right L: Izquierda / Gauche / Left

● En Existencia / En stock / In Stock ○ Artículo sin Existencia / Indisponible en Stock / Non Stock Item

Ejemplo de Pedido / Exemple de Commande / Ordering Example

1 Piezas / pcs. / pcs. CCLNR 2525 M1207C

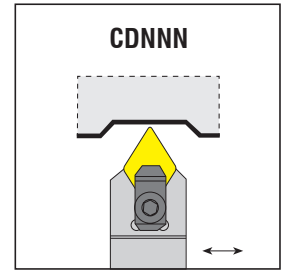
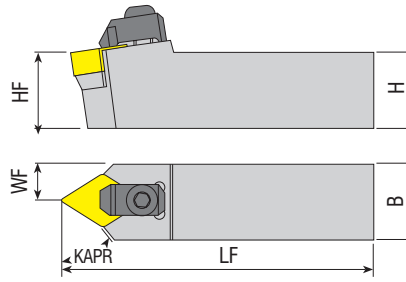

Código del Inserto Le Code de Commande Ordering Code	Stock Stock Stock	Dimension (mm) Dimension (mm) Dimension (mm)				Inserto Plaquette Insert	Recambios / Pièces de Rechange / Spare Parts					
		HF=H	B	LF	WF		Abrazadera de Cuñas Mode de Fixation Wedge Clamp	Tornillo de Sujeción Vis de Fixation Wedge Screw	Cuñas Assise Shim	Tornillo de Placa Vis a Assise Shim Screw	Anillo Bague Ring	Llaves Allen Clés Allen Allen Wrench
CDNNN 2525 M1107C	●	25	25	150	12.5							
						DN.N 1107..	ACK-22	AKV-11-M8x29	AADN-2-0001	AAV-04-M5x12	ACS-01	AAL-05-4

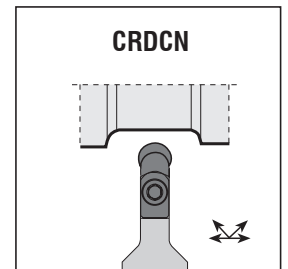
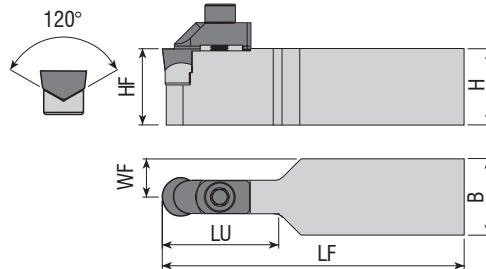

Código del Inserto Le Code de Commande Ordering Code	Stock Stock Stock	Dimension (mm) Dimension (mm) Dimension (mm)					Inserto Plaquette Insert	Recambios / Pièces de Rechange / Spare Parts				
		HF=H	B	LF	LU	WF		Abrazadera de Cuñas Mode de Fixation Wedge Clamp	Tornillo Vis Screw	Cuñas Assise Shim	Tornillo de Placa Vis a Assise Shim Screw	Llaves Allen Clés Allen Allen Wrench
CRDCN 2525 M06CV	●	25	25	150	19	12.5						
3225 P06CV	●	32	25	170	19	12.5	RCGX 0606..	ACK-27	2525-M3X14	AARC-3-0001	3007-M2.2X5	AAL-02-2.5
4040 S06CV	●	40	40	250	19	20						
2525 M09CV	●	25	25	150	29	12.5						
3225 P09CV	●	32	25	170	29	12.5	RCGX 0907..	ACK-28	2504-M5X16	AARC-3-0002	3008-M2.5x6	AAL-05-4
4040 S09CV	●	40	40	250	29	20						
2525 M12CV	●	25	25	150	38	12.5						
3225 P12CV	●	32	25	170	38	12.5	RCGX 1207..	ACK-29	2505-M6X20	AARC-3-0003	3008-M2.5x6	AAL-07-5
4040 S12CV	●	40	40	250	38	20						

R: Derecha / Droite / Right L: Izquierda / Gauche / Left

● En Existencia / En stock / In Stock ○ Artículo sin Existencia / Indisponible en Stock / Non Stock Item

Ejemplo de Pedido / Exemple de Commande / Ordering Example

1 Piezas / pcs. / pcs. CDNNN 2525 M1107C

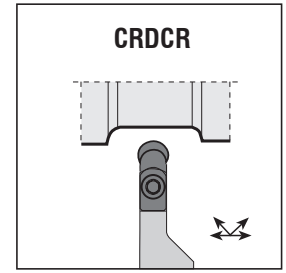
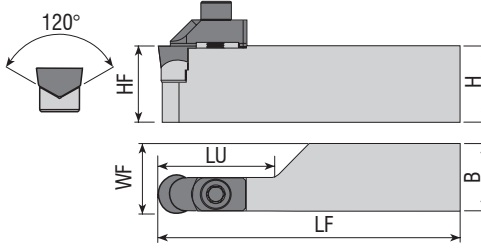

Código del Inserto Le Code de Commande Ordering Code	Stock Stock		Dimension (mm) Dimension (mm)				Inserto Plaquette Insert	Recambios / Pièces de Rechange / Spare Parts					
	R	L	HF=H	B	LF	LU		WF	Abrazadera de Cuñas Mode de Fixation Wedge Clamp	Tornillo Vis Screw	Cuñas Assise Shim	Tornillo de Placa Vis a Assise Shim Screw	Llaves Allen Clés Allen Allen Wrench
CRDCR/L 3225 P06CV	●	●	32	25	170	19.4	25.6	RCGX 0606..	ACK-27	2525-M3X14	AARC-3-0001	3007-M2.2X5	AAL-02-2.5
3225 P09CV	●	●	32	25	170	29	25.8	RCGX 0907..	ACK-28	2504-M5X16	AARC-3-0002	3008-M2.5x6	AAL-05-4
3225 P12CV	●	●	32	25	170	38.5	25.9	RCGX 1207..	ACK-29	2505-M6X20	AARC-3-0003	3008-M2.5x6	AAL-07-5

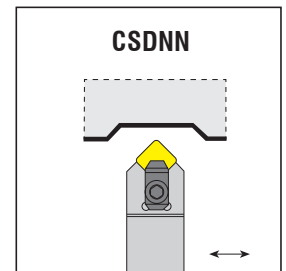
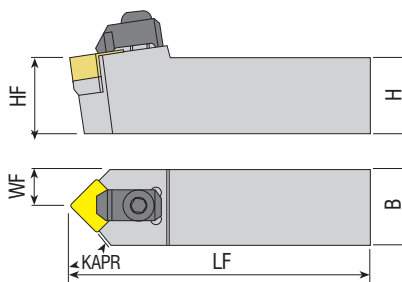

Código del Inserto Le Code de Commande Ordering Code	Stock Stock		Dimension (mm) Dimension (mm)				Inserto Plaquette Insert	Recambios / Pièces de Rechange / Spare Parts					
			HF=H	B	LF	WF		Abrazadera de Cuñas Mode de Fixation Wedge Clamp	Tornillo de Sujeción Vis de Fixation Wedge Screw	Cuñas Assise Shim	Tornillo de Placa Vis a Assise Shim Screw	Anillo Bague Ring	Llaves Allen Clés Allen Allen Wrench
CSDNN 2525 M1207C	●		25	25	150	12.5	SN.N 1207..	ACK-13	AKV-11-M8x29	AASN-3-0004	AAV-02-M5x12	ACS-01	AAL-05-4
3232 P1207C	●		32	32	170	16							

R: Derecha / Droite / Right L: Izquierda / Gauche / Left

● En Existencia / En stock / In Stock ○ Artículo sin Existencia / Indisponible en Stock / Non Stock Item

Ejemplo de Pedido / Exemple de Commande / Ordering Example

1 Piezas / pcs. / pcs. CRDCR 3225 P06CV

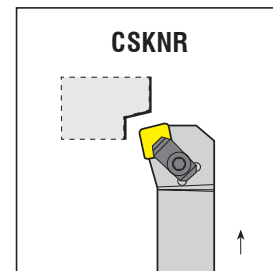
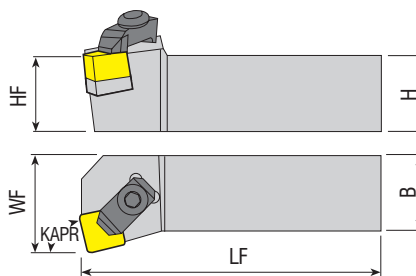

Código del Inserto Le Code de Commande Ordering Code	Stock Stock		Dimension (mm) Dimension (mm)				Inserto Plaquette Insert	Recambios / Pièces de Rechange / Spare Parts					
	R	L	HF=H	B	LF	WF		Abrazadera de Cuñas Mode de Fixation Wedge Clamp	Tornillo de Sujeción Vis de Fixation Wedge Screw	Cuñas Assise Shim	Tornillo de Placa Vis a Assise Shim Screw	Anillo Bague Ring	Llaves Allen Clés Allen Allen Wrench
CSKNR/L 2525 M1207C 3232 P1207C	●	●	25	25	150	32	SN.N 1207..						
	●	●	32	32	170	40							

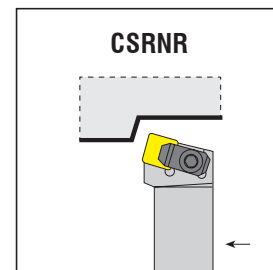
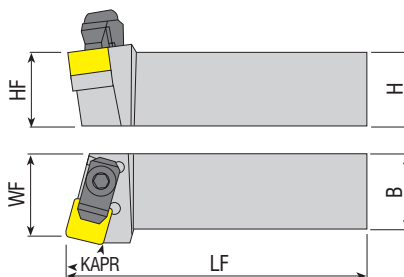

Código del Inserto Le Code de Commande Ordering Code	Stock Stock		Dimension (mm) Dimension (mm)				Inserto Plaquette Insert	Recambios / Pièces de Rechange / Spare Parts					
	R	L	HF=H	B	LF	WF		Abrazadera de Cuñas Mode de Fixation Wedge Clamp	Tornillo de Sujeción Vis de Fixation Wedge Screw	Cuñas Assise Shim	Tornillo de Placa Vis a Assise Shim Screw	Anillo Bague Ring	Llaves Allen Clés Allen Allen Wrench
CSRNR/L 2525 M1207C 3232 P1207C	●	●	25	25	150	32	SN.N 1207..						
	●	●	32	32	170	40							

R: Derecha / Droite / Right L: Izquierda / Gauche / Left

● En Existencia / En stock / In Stock ○ Artículo sin Existencia / Indisponible en Stock / Non Stock Item

Ejemplo de Pedido / Exemple de Commande / Ordering Example

1 Piezas / pcs. / pcs. CSKNR 2525 M1207C

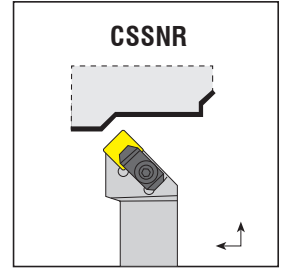
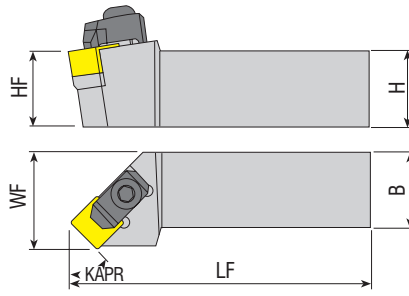

Código del Inserto Le Code de Commande Ordering Code	Stock		Dimension (mm) Dimension (mm)				Inserto Plaquette Insert	Recambios / Pièces de Rechange / Spare Parts					
	R	L	HF=H	B	LF	WF		Abrazadera de Cuñas Mode de Fixation Wedge Clamp	Tornillo de Sujeción Vis de Fixation Wedge Screw	Cuñas Assise Shim	Tornillo de Placa Vis a Assise Shim Screw	Anillo Bague Ring	Llaves Allen Clés Allen Allen Wrench
CSSNR/L 2525 M1207C 3232 P1207C	●	●	25	25	150	32	SN.N 1207..						
	●	●	32	32	170	40							

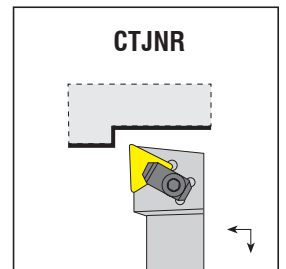
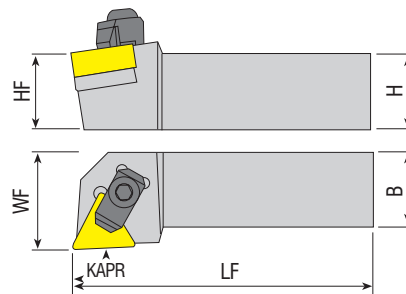

Código del Inserto Le Code de Commande Ordering Code	Stock		Dimension (mm) Dimension (mm)				Inserto Plaquette Insert	Recambios / Pièces de Rechange / Spare Parts					
	R	L	HF=H	B	LF	WF		Abrazadera de Cuñas Mode de Fixation Wedge Clamp	Tornillo de Sujeción Vis de Fixation Wedge Screw	Cuñas Assise Shim	Tornillo de Placa Vis a Assise Shim Screw	Anillo Bague Ring	Llaves Allen Clés Allen Allen Wrench
CTJNR/L 2525 M1607C 3232 P1607C	●	●	25	25	150	32	TN.N 1607..						
	○	○	32	32	170	40							

R: Derecha / Droite / Right L: Izquierda / Gauche / Left

● En Existencia / En stock / In Stock ○ Artículo sin Existencia / Indisponible en Stock / Non Stock Item

Ejemplo de Pedido / Exemple de Commande / Ordering Example

1 Piezas / pcs. / pcs. CSSNR 2525 M1207C



*konusulan
the spoken kalite...
quality...*

S-SYSTEM

PORTA HERRAMIENTAS DE TORNEADO EXTERNO SISTEMA-S
PORTE-OUTILS POUR TOURNAGE EXTERIEUR SYSTEME-S
S-SYSTEM EXTERNAL TURNING TOOLHOLDERS



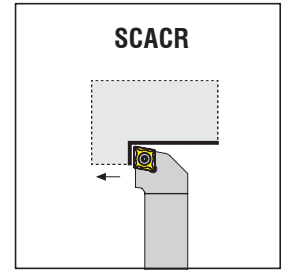
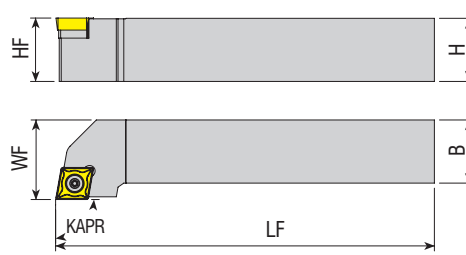
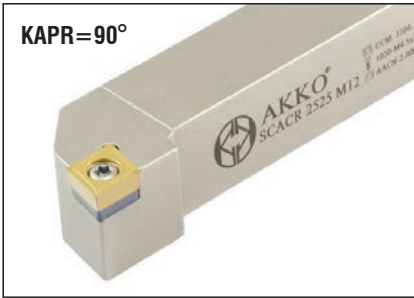

Código del Inserto
 Le Code de Commande
 Ordering Code

Código del Inserto Le Code de Commande Ordering Code	Stock Stock		Dimension (mm) Dimension (mm) Dimension (mm)				Inserto Plaquette Insert	Recambios / Pièces de Rechange / Spare Parts				
	R	L	HF=H	B	LF	WF		Tornillo Vis Screw	Cuñas Assise Shim	Tornillo de Placa Vis a Assise Shim Screw	Llave Torx Clé Torx Torx Wrench	
SCACR/L 0808 E06	●	●	08	08	70	10						
1010 E06	●	●	10	10	70	12						
1212 F09	●	●	12	12	80	16						
1616 H09	●	●	16	16	100	20	CC.T 09T3..	4015-M3.5x11	AACN-2-0001	AAV-06-M3.5x11	80-T15	
2020 K09	●	●	20	20	125	25						
2020 K12	●	●	20	20	125	25	CC.T 1204..	1020-M4.5x16	AACN-2-0003	AAV-07-M4.5x13	80-T20	
2525 M12	●	●	25	25	150	32						

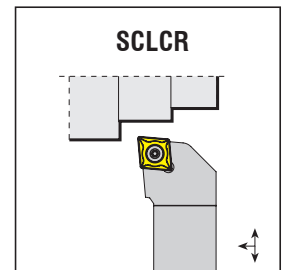
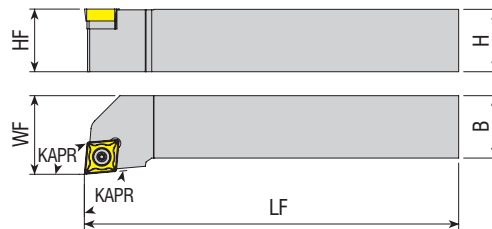
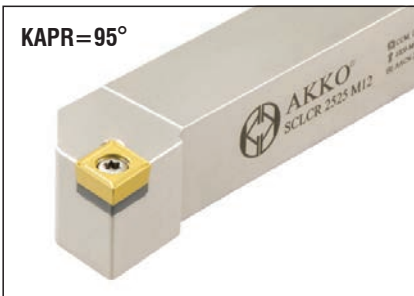

Código del Inserto
 Le Code de Commande
 Ordering Code

Código del Inserto Le Code de Commande Ordering Code	Stock Stock		Dimension (mm) Dimension (mm) Dimension (mm)				Inserto Plaquette Insert	Recambios / Pièces de Rechange / Spare Parts				
	R	L	HF=H	B	LF	WF		Tornillo Vis Screw	Cuñas Assise Shim	Tornillo de Placa Vis a Assise Shim Screw	Llave Torx Clé Torx Torx Wrench	
SCLCR/L 0808 E06	●	●	08	08	70	10						
1010 E06	●	○	10	10	70	12						
1212 F06	●	●	12	12	80	16						
1010 E09	●	●	10	10	70	12	CC.T 09T3..	4015-M3x9	AACN-2-0001	AAV-06-M3.5x11	80-T15	
1212 F09	●	●	12	12	80	16						
1616 H09	●	●	16	16	100	20						
2020 K09	●	●	20	20	125	25						
2525 M09	●	●	25	25	150	32						
1616 H12	●	○	16	16	100	20	CC.T 1204..	1020-M5x11	AACN-2-0003	AAV-07-M4.5x13	80-T20	
2020 K12	●	●	20	20	125	25						
2525 M12	●	●	25	25	150	32						

R: Derecha / Droite / Right L: Izquierda / Gauche / Left

● En Existencia / En stock / In Stock ○ Artículo sin Existencia / Indisponible en Stock / Non Stock Item

Ejemplo de Pedido / Exemple de Commande / Ordering Example

1 Piezas / pcs. / pcs. SCACR 0808 E06

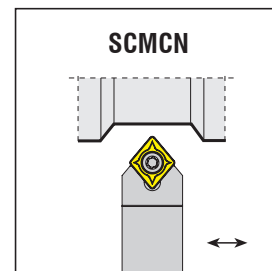
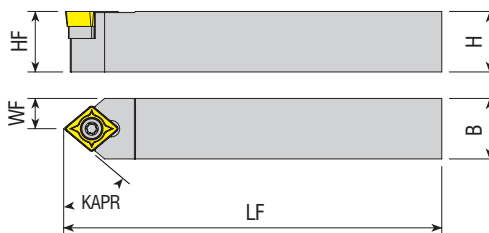

Código del Inserto Le Code de Commande Ordering Code	Stock Stock	Dimension (mm) Dimension (mm)				Inserto Plaquette Insert	Recambios / Pièces de Rechange / Spare Parts								
		HF=H	B	LF	WF		Tornillo Vis Screw	Cuñas Assise Shim	Tornillo de Placa Vis a Assise Shim Screw	Llave Torx Clé Torx Torx Wrench					
SCMCN 0808 E06	●	08	08	70	04										
1010 E06	●	10	10	70	05						CCM. 0602..	4008-M2.5x6	-	-	80-T08
1212 F06	●	12	12	80	06						CC.T 09T3..	4015-M3.5x11	-	-	80-T15
1212 F09	●	12	12	80	06	4015-M3.5x14	AACN-2-0001	AAV-06-M3.5x11	80-T15						
1616 H09	●	16	16	100	08	CC.T 1204..	1020-M4.5x16	AACN-2-0003	AAV-07-M4.5x13	80-T20					
2020 K12	●	20	20	125	10										
2525 M12	●	25	25	150	12.5										

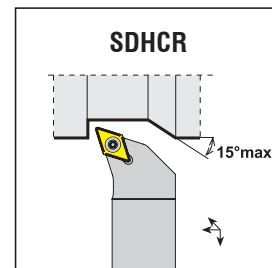
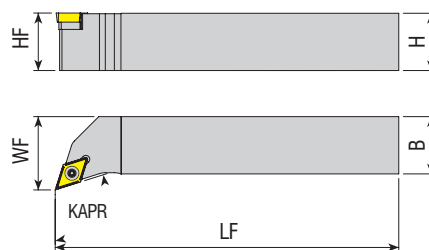

Código del Inserto Le Code de Commande Ordering Code	Stock Stock	Dimension (mm) Dimension (mm)				Inserto Plaquette Insert	Recambios / Pièces de Rechange / Spare Parts									
		R	L	HF=H	B		LF	WF	Tornillo Vis Screw	Cuñas Assise Shim	Tornillo de Placa Vis a Assise Shim Screw	Llave Torx Clé Torx Torx Wrench				
SDHCR/L 0808 E07	●	●	08	08	70	11										
1010 E07	●	●	10	10	70	12						DC.T 0702..	4008-M2.5x6	-	-	80-T08
1212 F07	●	●	12	12	80	16						DC.T 11T3..	4015-M3.5x14	AADN-2-0001	AAV-06-M3.5x11	80-T15
1616 H07	●	●	16	16	100	20										
1616 H11	●	●	16	16	100	20	DC.T 11T3..	4015-M3.5x14	AADN-2-0001	AAV-06-M3.5x11	80-T15					
2020 K11	●	●	20	20	125	25										
2525 M11	●	●	25	25	150	32										
3232 P11	●	●	32	32	170	40										

R: Derecha / Droite / Right L: Izquierda / Gauche / Left
 ● En Existencia / En stock / In Stock ○ Artículo sin Existencia / Indisponible en Stock / Non Stock Item

Ejemplo de Pedido / Exemple de Commande / Ordering Example
 1 Piezas / pcs. / pcs. SCMCN 0808 E06

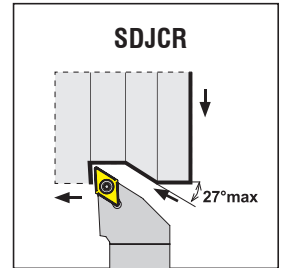
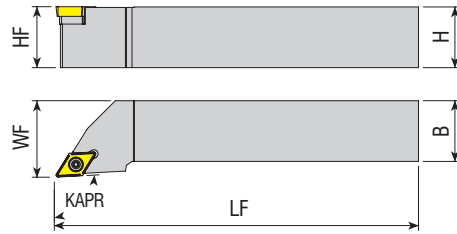
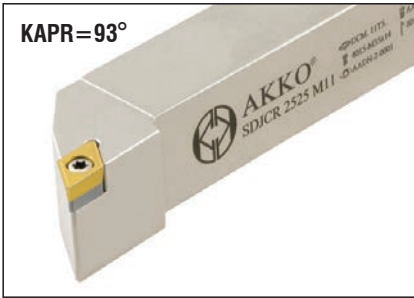

Código del Inserto Le Code de Commande Ordering Code	Dimension (mm) Dimension (mm)						Inserto Plaquette Insert	Tornillo Vis Screw	Cuñas Assise Shim	Tornillo de Placa Vis a Assise Shim Screw	Llave Torx Clé Torx Torx Wrench
	Stock Stock		HF=H	B	LF	WF					
	R	L									
SDJCR/L 0808 E07	●	●	08	08	70	10		4008-M2.5x6	-	-	80-T08
1010 E07	●	●	10	10	70	12					
1212 F07	●	●	12	12	80	16					
1616 H07	●	●	16	16	100	20					
1616 H11	●	●	16	16	100	20		4015-M3.5x14	AADN-2-0001	AAV-06-M3.5x11	80-T15
2020 K11	●	●	20	20	125	25					
2525 M11	●	●	25	25	150	32					
3232 P11	●	●	32	32	170	40					

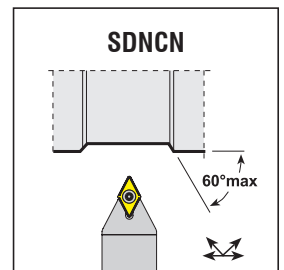
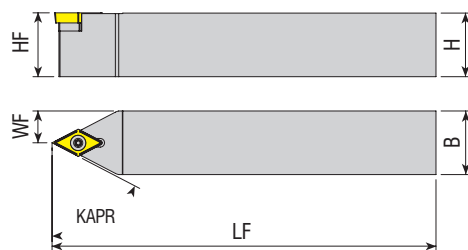

Código del Inserto Le Code de Commande Ordering Code	Dimension (mm) Dimension (mm)						Inserto Plaquette Insert	Tornillo Vis Screw	Cuñas Assise Shim	Tornillo de Placa Vis a Assise Shim Screw	Llave Torx Clé Torx Torx Wrench
	Stock Stock		HF=H	B	LF	WF					
	R	L									
SDNCN 0808 E07	●		08	08	70	4		4008-M2.5x6	-	-	80-T08
1010 E07	●		10	10	70	5					
1212 F07	●		12	12	80	6					
1616 H07	●		16	16	100	8					
1616 H11	●		16	16	100	8		4015-M3.5x14	AADN-2-0001	AAV-06-M3.5x11	80-T15
2020 K11	●		20	20	125	10					
2525 M11	●		25	25	150	12.5					
3232 P11	●		32	32	170	16					

R: Derecha / Droite / Right L: Izquierda / Gauche / Left

● En Existencia / En stock / In Stock ○ Artículo sin Existencia / Indisponible en Stock / Non Stock Item

Ejemplo de Pedido / Exemple de Commande / Ordering Example
 1 Piezas / pcs. / pcs. SDJCR 0808 E07

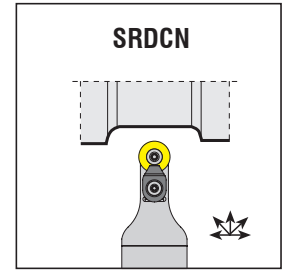
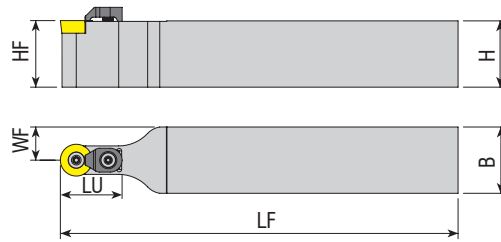

Código del Inserto
 Le Code de Commande
 Ordering Code

Código del Inserto Le Code de Commande Ordering Code	Stock Stock Stock	Dimension (mm) Dimension (mm) Dimension (mm)					Inserto Plaquette Insert	Recambios / Pièces de Rechange / Spare Parts						
		HF=H	B	LF	LU	WF		Tornillo Vis Screw	Cuñas Assise Shim	Tornillo de Placa Vis a Assise Shim Screw	Abrazadera de Cuñas Mode de Fixation Wedge Clamp	Tornillo de Sujeción Vis de Fixation Wedge Screw	Llave Torx Clé Torx Torx Wrench	
SRDCN 1616 H06	●	16	16	100	15	8	RC.T 0602..	3008-M2.5x6	-	-	-	-	-	80-T08
2020 K06	●	20	20	125	17	10								
2525 M06	●	25	25	150	17	12.5								
1616 H08C	●	16	16	100	15	8	RC.T 0803..	3008-M3x8	-	-	-	-	-	
2020 K08C	●	20	20	125	20	10								
2525 M08C	●	25	25	150	20	12.5								
1616 H10C	●	16	16	100	20	8	RC.T 10T3..	4015-M3.5x11	-	-	ACK-15	4015-M3.5x11	-	
2020 K10C	●	20	20	125	20	10								
2525 M10C	●	25	25	150	20	12.5								
3232 P10C	●	32	32	170	20	16								
2020 K12C	●	20	20	125	22	10	RC.T 1204..	4015-M3.5x11	-	-	-	-	80-T15	
2525 M12C	●	25	25	150	22	12.5								
3232 P12C	●	32	32	170	22	16								
2525 M16C	●	25	25	150	32	12.5	RC.T 1605..	1020-M5x11	-	-	ACK-05	4015-M4x11	-	
3232 P16C	●	32	32	170	35	16								
2525 M20C	●	25	25	150	32	12.5	RC.T 2006..	1420-M6x16	-	-	ACK-09	AAV-05-M6x15	80-T20	
3232 P20C	●	32	32	170	40	16								
3232 P25C	●	32	32	170	40	16								
3232 P32C	●	32	32	170	45	16								
RC.T 2507..								1520-M6x16						
RC.T 3209..								1904-M8x1x20						AAL-05-4

R: Derecha / Droite / Right L: Izquierda / Gauche / Left

● En Existencia / En stock / In Stock ○ Artículo sin Existencia / Indisponible en Stock / Non Stock Item

Ejemplo de Pedido / Exemple de Commande / Ordering Example

1 Piezas / pcs. / pcs. SRDCN 1616 H06



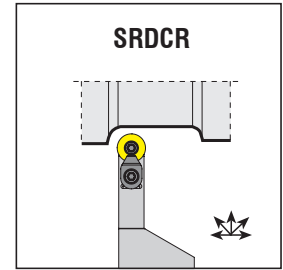
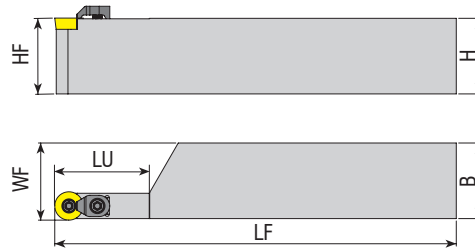

Código del Inserto
 Le Code de Commande
 Ordering Code

Código del Inserto Le Code de Commande Ordering Code	Stock Stock		Dimension (mm) Dimension (mm) Dimension (mm)				Inserto Plaqueite Insert	Recambios / Pièces de Rechange / Spare Parts						
	R	L	HF=H	B	LF	LU		WF	Tornillo Vis Screw	Cuñas Assise Shim	Tornillo de Placa Vis a Assise Shim Screw	Abrazadera de Cuñas Mode de Fixation Wedge Clamp	Tornillo de Sujeción Vis de Fixation Wedge Screw	Llave Torx Cle Torx Torx Wrench
SRDCR/L 3232 T06	●	●	32	32	300	20	32.35			-	-	-	-	80-T08
3232 P12C	●	●	32	32	170	40	32.65			-	-	ACK-05	4015-M4x11	80-T15

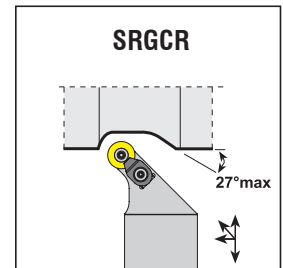
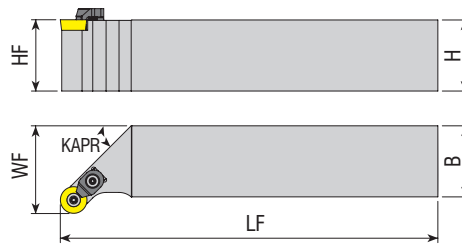

Código del Inserto
 Le Code de Commande
 Ordering Code

Código del Inserto Le Code de Commande Ordering Code	Stock Stock		Dimension (mm) Dimension (mm) Dimension (mm)				Inserto Plaqueite Insert	Recambios / Pièces de Rechange / Spare Parts					
	R	L	HF=H	B	LF	WF		Tornillo Vis Screw	Cuñas Assise Shim	Tornillo de Placa Vis a Assise Shim Screw	Abrazadera de Cuñas Mode de Fixation Wedge Clamp	Tornillo de Sujeción Vis de Fixation Wedge Screw	Llave Torx Cle Torx Torx Wrench
SRGCR/L 1616 H06	●	●	16	16	100	20	RC.T 0602..		-	-	-	-	80-T08
2020 K06	●	●	20	20	125	25							
1616 H08C	●	●	16	16	100	20	RC.T 0803..		-	-	ACK-15	4015-M3.5x11	80-T15
2020 K08C	●	●	20	20	125	25							
2525 M08C	●	●	25	25	150	32	RC.T 10T3..		-	-	ACK-05	4015-M4x11	
1616 H10C	●	●	16	16	100	20							
2020 K10C	●	●	20	20	125	25							
2525 M10C	●	●	25	25	150	32							
3232 P10C	●	●	32	32	170	40	RC.T 1204..		-	-	ACK-05	4015-M4x11	
2020 K12C	●	●	20	20	125	25							
2525 M12C	●	●	25	25	150	32							
3232 P12C	●	●	32	32	170	40							

R: Derecha / Droite / Right L: Izquierda / Gauche / Left

● En Existencia / En stock // In Stock ○ Artículo sin Existencia / Indisponible en Stock / Non Stock Item

Ejemplo de Pedido / Exemple de Commande / Ordering Example

1 Piezas / pcs. / pcs. SRDCR 3232 T06

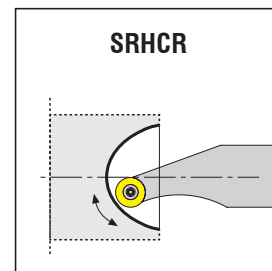
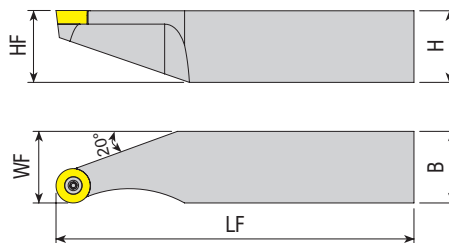

Código del Inserto Le Code de Commande Ordering Code	Dimension (mm) Dimension (mm) Dimension (mm)							Inserto Plaquette Insert	Recambios / Pièces de Rechange / Spare Parts				
	Stock Stock Stock		HF=H	B	LF	WF	MIN R		Tornillo Vis Screw	Cuñas Assise Shim	Tornillo de Placa Vis a Assise Shim Screw	Llave Torx Clé Torx Torx Wrench	
	R	L											
SRHCR/L 2525 K06	●	○	25	25	125	25	32.5						
2525 K08	●	●	25	25	125	25	32.5	RC.T 0602..	3008-M2.5x6	-	-	80-T08	
2525 K10	●	●	25	25	125	25	36	RC.T 0803..	3008-M3x8	-	-	80-T08	
2525 K12	●	●	25	25	125	25	40	RC.T 10T3..	4015-M3.5x11	-	-	80-T15	
2525 K16	●	●	25	25	125	25	47.5	RC.T 1204..	1020-M5x11	-	-	80-T20	

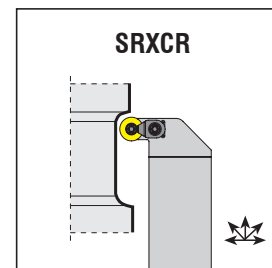
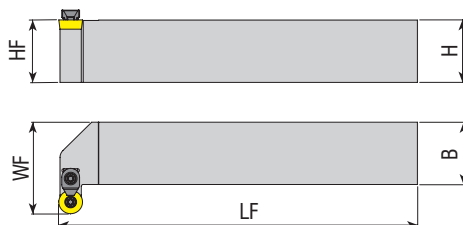

Código del Inserto Le Code de Commande Ordering Code	Dimension (mm) Dimension (mm) Dimension (mm)						Inserto Plaquette Insert	Recambios / Pièces de Rechange / Spare Parts					
	Stock Stock Stock		HF=H	B	LF	WF		Tornillo Vis Screw	Cuñas Assise Shim	Tornillo de Placa Vis a Assise Shim Screw	Abrazadera de Cuñas Mode de Fixation Wedge Clamp	Tornillo de Sujeción Vis de Fixation Wedge Screw	Llave Torx Clé Torx Torx Wrench
	R	L											
SRXCR/L 3232 X08C	●	●	32	32	220	47							
3232 X10C	●	●	32	32	220	47	RC.T 0803..	3008-M3x8	-	-	ACK-15	4015-M3.5x11	80-T08
3232 X12C	●	●	32	32	220	47	RC.T 10T3..	4015-M3.5x11	-	-	ACK-05	4015-M4x11	80-T15
							RC.T 1204..						

R: Derecha / Droite / Right L: Izquierda / Gauche / Left

● En Existencia / En stock / In Stock ○ Artículo sin Existencia / Indisponible en Stock / Non Stock Item

Ejemplo de Pedido / Exemple de Commande / Ordering Example

1 Piezas / pcs. / pcs. SRHCR 2525 K06

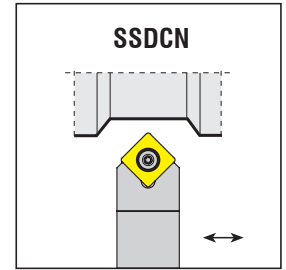
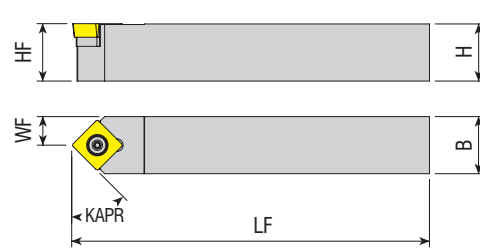

Código del Inserto Le Code de Commande Ordering Code	Stock		Dimension (mm) Dimension (mm) Dimension (mm)				Inserto Plaqueette Insert	Recambios / Pièces de Rechange / Spare Parts				
	R	L	HF=H	B	LF	WF		Tornillo Vis Screw	Cuñas Assise Shim	Tornillo de Placa Vis a Assise Shim Screw	Llave Torx Clé Torx Torx Wrench	
SSDCN 1212 F09	●		12	12	80	6	SC.T 09T3..	4015-M3.5x11	-	-	80-T15	
1616 H09	●		16	16	100	8		4015-M3.5x14	AASN-2-0001	AAV-06-M3.5x11		
2020 K09	●		20	20	125	10		4020-M4.5x12		AAV-10-M4.5x8		
1616 H12	●		16	16	100	8	SC.T 1204..	1020-M4.5x16	AASN-2-0004	AAV-07-M4.5x13	80-T20	
2020 K12	●		20	20	125	10						
2525 M12	●		25	25	150	12.5						

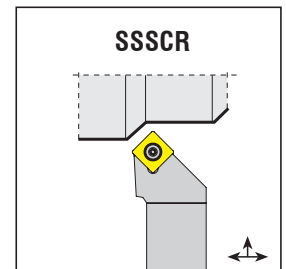
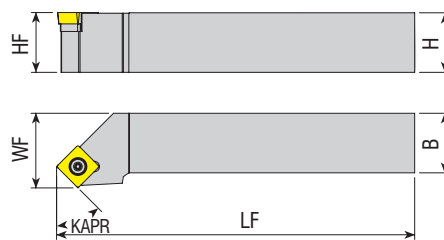

Código del Inserto Le Code de Commande Ordering Code	Stock		Dimension (mm) Dimension (mm) Dimension (mm)				Inserto Plaqueette Insert	Recambios / Pièces de Rechange / Spare Parts				
	R	L	HF=H	B	LF	WF		Tornillo Vis Screw	Cuñas Assise Shim	Tornillo de Placa Vis a Assise Shim Screw	Llave Torx Clé Torx Torx Wrench	
SSSCR/L 1212 F09	●	●	12	12	80	16	SC.T 09T3..	4015-M3.5x11	-	-	80-T15	
1616 H09	●	●	16	16	100	20		4015-M3.5x14	AASN-2-0001	AAV-06-M3.5x11		
2020 K09	●	●	20	20	125	25		4020-M4.5x12		AAV-10-M4.5x8		
1616 H12	●	●	16	16	100	20	SC.T 1204..	1020-M4.5x16	AASN-2-0004	AAV-07-M4.5x13	80-T20	
2020 K12	●	●	20	20	125	25						
2525 M12	●	●	25	25	150	32						

R: Rechts / Destro / Right L: Links / Sinistro / Left

● Auf Lager / A Magazzino / In Stock ○ Kein Lagerartikel, Lieferzeit auf Anfrage / Non Disponibile / Non Stock Item

Bestellbeispiel/Esempio D'ordine/Ordering Example

1 stück/pezzo./pcs. SSDCN 1212 F09

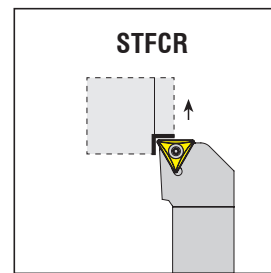
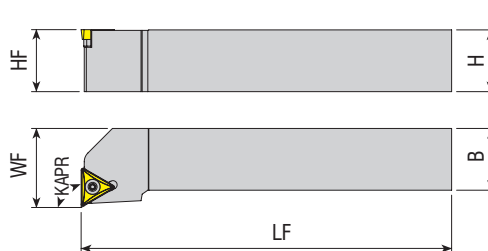

Código del Inserto Le Code de Commande Ordering Code	Stock		Dimension (mm) Dimension (mm)				Inserto Plaquette Insert	Recambios / Pièces de Rechange / Spare Parts			
	R	L	HF=H	B	LF	WF		Tornillo Vis Screw	Cuñas Assise Shim	Tornillo de Placa Vis a Assise Shim Screw	Llave Torx Clé Torx Torx Wrench
STFGR/L 0808 E09	○	○	08	08	70	10					
1010 E09	●	●	10	10	70	12					
1212 F11	●	●	12	12	80	16					
1616 H11	●	●	16	16	100	20	TC.T 1102..	4008-M2.5x6	-	-	80-T08
1616 H16	●	●	16	16	100	20					
2020 K16	●	●	20	20	125	25	TC.T 16T3..	4015-M3.5x14	AATN-2-0001	AAV-06-M3.5x11	80-T15
2525 M16	●	●	25	25	150	32					
3232 P16	●	●	32	32	170	40					

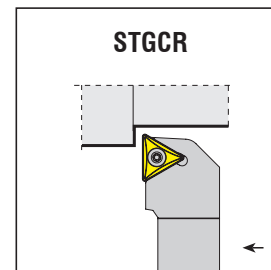
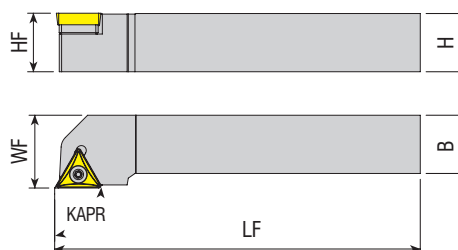

Código del Inserto Le Code de Commande Ordering Code	Stock		Dimension (mm) Dimension (mm)				Inserto Plaquette Insert	Recambios / Pièces de Rechange / Spare Parts			
	R	L	HF=H	B	LF	WF		Tornillo Vis Screw	Cuñas Assise Shim	Tornillo de Placa Vis a Assise Shim Screw	Llave Torx Clé Torx Torx Wrench
STGCR/L 0808 E09	●	●	08	08	70	10					
1010 E09	●	●	10	10	70	12					
1212 F11	●	●	12	12	80	16					
1616 H11	●	●	16	16	100	20	TC.T 1102..	4008-M2.5x6	-	-	80-T08
1616 H16	●	●	16	16	100	20					
2020 K16	●	●	20	20	125	25	TC.T 16T3..	4015-M3.5x14	AATN-2-0001	AAV-06-M3.5x11	80-T15
2525 M16	●	●	25	25	150	32					
3232 P16	●	●	32	32	170	40					

R: Derecha / Droite / Right L: Izquierda / Gauche / Left

● En Existencia / En stock / In Stock ○ Articulo sin Existencia / Indisponible en Stock / Non Stock Item

Ejemplo de Pedido / Exemple de Commande / Ordering Example

1 Piezas / pcs. / pcs. STFGR 0808 E09

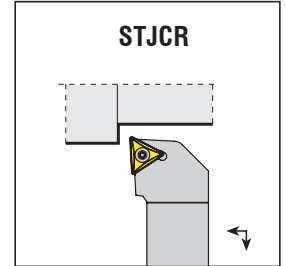
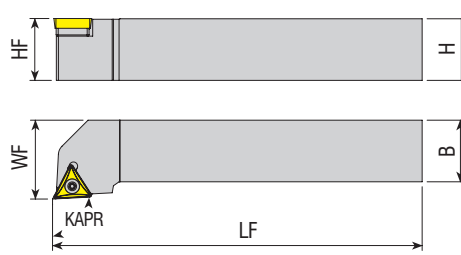
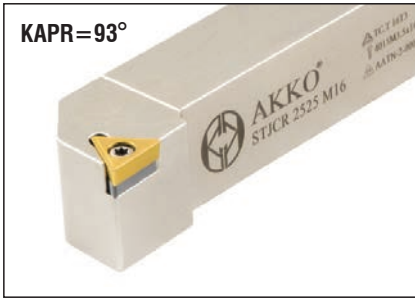

Código del Inserto
 Le Code de Commande
 Ordering Code

Stock Stock	R	L	Dimension (mm) Dimension (mm)			Inserto Plaquette Insert	Recambios / Pièces de Rechange / Spare Parts				
			HF=H	B	LF		WF	Tornillo Vis Screw	Cuñas Assise Shim	Tornillo de Placa Vis a Assise Shim Screw	Llave Torx Clé Torx Torx Wrench
STJCR/L 0808 E09	●	●	08	08	70	10	TC.T 0902..	3007-M2.2x5	-	-	80-T07
1010 E09	●	●	10	10	70	12					
1212 F11	●	●	12	12	80	16	TC.T 1102..	4008-M2.5x6	-	-	80-T08
1616 H11	●	●	16	16	100	20					
1616 H16	●	●	16	16	100	20	TC.T 16T3..	4015-M3.5x14	AATN-2-0001	AAV-06-M3.5x11	80-T15
2020 K16	●	●	20	20	125	25					
2525 M16	●	●	25	25	150	32					
3232 P16	●	●	32	32	170	40					

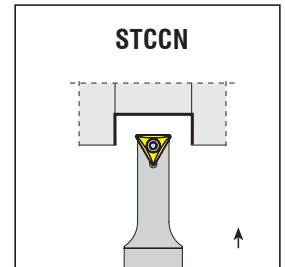
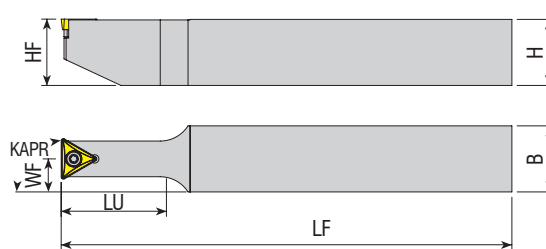

Código del Inserto
 Le Code de Commande
 Ordering Code

Stock Stock	HF=H	B	Dimension (mm) Dimension (mm)			Inserto Plaquette Insert	Recambios / Pièces de Rechange / Spare Parts				
			LF	WF	LU		Tornillo Vis Screw	Cuñas Assise Shim	Tornillo de Placa Vis a Assise Shim Screw	Llave Torx Clé Torx Torx Wrench	
STCCN 2020 L11	●	20	20	140	10	50	TC.T 1102..	4008-M2.5x6	-	-	80-T08
1616 K16	●	16	16	125	8	24					
2020 M16	●	20	20	150	10	30	TC.T 16T3..	4015-M3.5x14	AATN-2-0001	AAV-06-M3.5x11	80-T15
2525 P16	●	25	25	170	12.5	37.5					
3232 R16	●	32	32	200	16	48					
2525 P22	●	25	25	170	12.5	80					
							TC.T 2204..	4020-M4.5x12	-	-	80-T20

R: Derecha / Droite / Right L: Izquierda / Gauche / Left

● En Existencia / En stock / In Stock ○ Artículo sin Existencia / Indisponible en Stock / Non Stock Item

Ejemplo de Pedido / Exemple de Commande / Ordering Example

1 Piezas / pcs. / pcs. STJCR 0808 E09

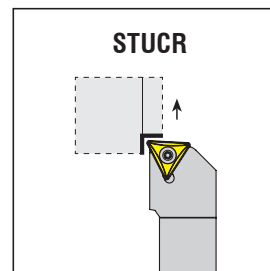
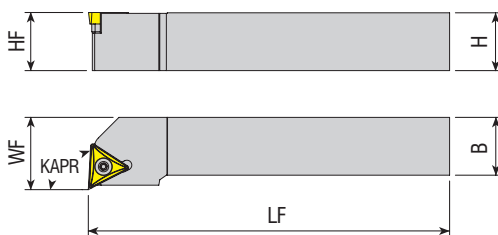

Código del Inserto Le Code de Commande Ordering Code	Stock						Recambios / Pièces de Rechange / Spare Parts				
	Stock		Dimension (mm) Dimension (mm) Dimension (mm)				Inserto Plaquette Insert	Tornillo Vis Screw	Cuñas Assise Shim	Tornillo de Placa Vis a Assise Shim Screw	Llave Torx Clé Torx Torx Wrench
	R	L	HF=H	B	LF	WF					
STUCR/L 0808 E09	●	●	08	08	70	10	TC.T 0902..	3007-M2.2x5	-	-	80-T07
1010 E09	●	●	10	10	70	12					
1212 F11	●	●	12	12	80	16					
1616 H11	●	●	16	16	100	20	TC.T 1102..	4008-M2.5x6	-	-	80-T08
1616 H16	○	○	16	16	100	20					
2020 K16	●	●	20	20	125	25	TC.T 16T3..	4015-M3.5x14	AATN-2-0001	AAV-06-M3.5x11	80-T15
2525 M16	●	●	25	25	150	32					
3232 P16	●	●	32	32	170	40					

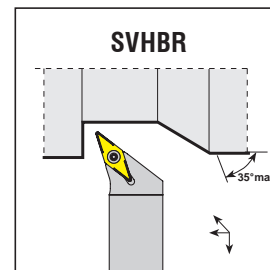
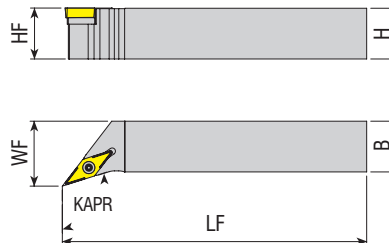

Código del Inserto Le Code de Commande Ordering Code	Stock						Recambios / Pièces de Rechange / Spare Parts				
	Stock		Dimension (mm) Dimension (mm) Dimension (mm)				Inserto Plaquette Insert	Tornillo Vis Screw	Cuñas Assise Shim	Tornillo de Placa Vis a Assise Shim Screw	Llave Torx Clé Torx Torx Wrench
	R	L	HF=H	B	LF	WF					
SVHBR/L 1212 F11	●	●	12	12	80	16	VB.T 1103..	4008-M2.5x6	-	-	80-T08
1616 H11	●	●	16	16	100	20					
2020 K11	●	●	20	20	125	25					
2020 K16	●	●	20	20	125	25	VB.T 1604..	4015-M3.5x14	AAVN-2-0002	AAV-06-M3.5x11	80-T15
2525 M16	●	●	25	25	150	32					
3232 P16	●	●	32	32	170	40					

R: Derecha / Droite / Right L: Izquierda / Gauche / Left

● En Existencia / En stock / In Stock ○ Artículo sin Existencia / Indisponible en Stock / Non Stock Item

Ejemplo de Pedido / Exemple de Commande / Ordering Example

1 Piezas / pcs. / pcs. STUCR 0808 E09

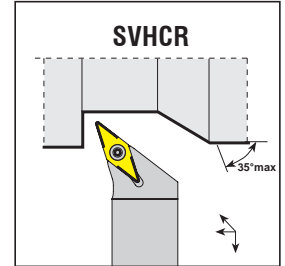
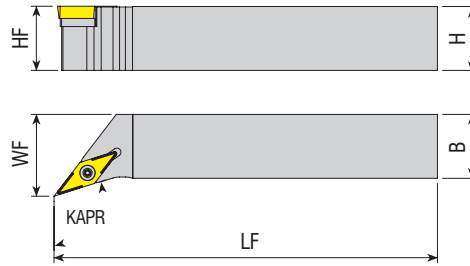
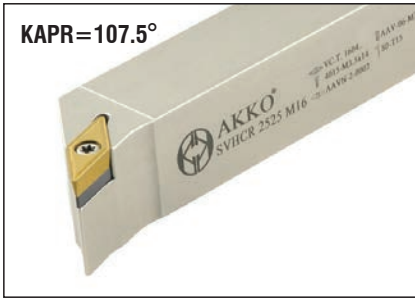

Código del Inserto Le Code de Commande Ordering Code		Dimension (mm) Dimension (mm) Dimension (mm)						Recambios / Pièces de Rechange / Spare Parts				
		Stock Stock Stock		HF=H	B	LF	WF	Inserto Plaquette Insert	Tornillo Vis Screw	Cuñas Assise Shim	Tornillo de Placa Vis a Assise Shim Screw	Llave Torx Clé Torx Torx Wrench
		R	L									
SVHCR/L 1212 F11	● ●	12	12	80	16	VC.T 1103..		4008-M2.5x6	-			
1616 H11	● ●	16	16	100	20							
2020 K11	● ●	20	20	125	25							
2020 K16	● ●	20	20	125	25	VC.T 1604..		4015-M3.5x14	AAVN-2-0002	AAV-06-M3.5x11		
2525 M16	● ●	25	25	150	32							
3232 P16	● ●	32	32	170	40							

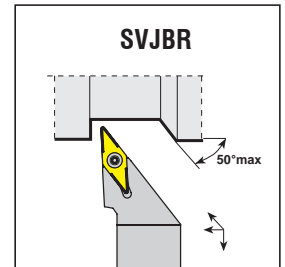
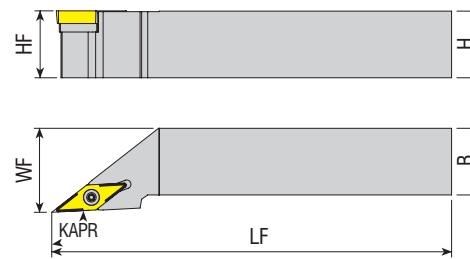

Código del Inserto Le Code de Commande Ordering Code		Dimension (mm) Dimension (mm) Dimension (mm)						Recambios / Pièces de Rechange / Spare Parts				
		Stock Stock Stock		HF=H	B	LF	WF	Inserto Plaquette Insert	Tornillo Vis Screw	Cuñas Assise Shim	Tornillo de Placa Vis a Assise Shim Screw	Llave Torx Clé Torx Torx Wrench
		R	L									
SVJBR/L 1212 F11	● ●	12	12	80	16	VB.T 1103..		4008-M2.5x6	-			
1616 H11	● ●	16	16	100	20							
2020 K11	● ●	20	20	125	25							
1616 H16	● ●	16	16	100	20	VB.T 1604..		4015-M3.5x14	AAVN-2-0002	AAV-06-M3.5x11		
2020 K16	● ●	20	20	125	25							
2525 M16	● ●	25	25	150	32							
3232 P16	● ●	32	32	170	40							

R: Derecha / Droite / Right L: Izquierda / Gauche / Left

● En Existencia / En stock / In Stock ○ Artículo sin Existencia / Indisponible en Stock / Non Stock Item

Ejemplo de Pedido / Exemple de Commande / Ordering Example

1 Piezas / pcs. / pcs. SVHCR 1212 F11

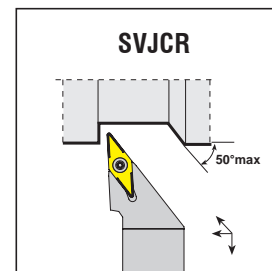
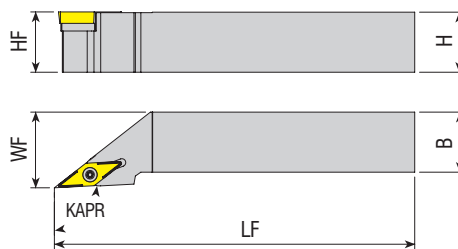

Código del Inserto Le Code de Commande Ordering Code	Stock						Inserto Plaquette Insert	Recambios / Pièces de Rechange / Spare Parts				
	Stock		Dimension (mm) Dimension (mm)					Tornillo Vis Screw	Cuñas Assise Shim	Tornillo de Placa Vis a Assise Shim Screw	Llave Torx Clé Torx Torx Wrench	
	R	L	HF=H	B	LF	WF						
SVJCR/L 1212 F11	●	●	12	12	80	16	VC.T 1103..	4008-M2.5x6	-	-	80-T08	
1616 H11	●	●	16	16	100	20						
2020 K11	●	●	20	20	125	25						
2525 M11	●	●	25	25	150	32						
1212 F16	●	●	12	12	80	16	VC.T 1604..	4015-M3.5x11	AAVN-2-0002	AAV-06-M3.5x11	80-T15	
2020 K16	●	●	20	20	125	25		4015-M3.5x14				
2525 M16	●	●	25	25	150	32						
3232 P16	●	●	32	32	170	40						

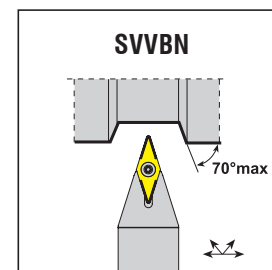
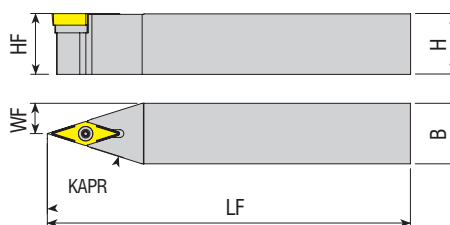

Código del Inserto Le Code de Commande Ordering Code	Stock						Inserto Plaquette Insert	Recambios / Pièces de Rechange / Spare Parts				
	Stock		Dimension (mm) Dimension (mm)					Tornillo Vis Screw	Cuñas Assise Shim	Tornillo de Placa Vis a Assise Shim Screw	Llave Torx Clé Torx Torx Wrench	
			HF=H	B	LF	WF						
SVVBN 1212 F11	●		12	12	80	06	VB.T 1103..	4008-M2.5x6	-	-	80-T08	
1616 H11	●		16	16	100	08						
2020 K11	●		20	20	125	10						
2020 K16	●		20	20	125	10						
2525 M16	●		25	25	150	12.5	VB.T 1604..	4015-M3.5x14	AAVN-2-0002	AAV-06-M3.5x11	80-T15	
3232 P16	●		32	32	170	16						

R: Derecha / Droite / Right L: Izquierda / Gauche / Left

● En Existencia / En stock / In Stock ○ Artículo sin Existencia / Indisponible en Stock / Non Stock Item

Ejemplo de Pedido / Exemple de Commande / Ordering Example

1 Piezas / pcs. / pcs. SVJCR 1212 F11

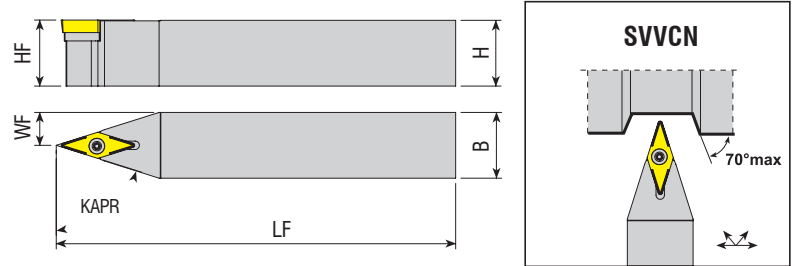

Código del Inserto Le Code de Commande Ordering Code	Stock Stock Stock	Dimension (mm) Dimension (mm) Dimension (mm)				Inserto Plaque Insert	Recambios / Pièces de Rechange / Spare Parts			
		HF=H	B	LF	WF		Tornillo Vis Screw	Cuñas Assise Shim	Tornillo de Placa Vis a Assise Shim Screw	Llave Torx Clé Torx Torx Wrench
SVVCN 1212 F11	●	12	12	80	06					
1616 H11	●	16	16	100	08					
2020 K11	●	20	20	125	10					
2020 K16	●	20	20	125	10					
2525 M16	●	25	25	150	12.5					
3232 P16	●	32	32	170	16					

S-SISTEMA HERRAMIENTAS PARA TORNOS AUTOMÁTICOS CORREDIZO TIPO SUIZO
 OUTILS DE TYPE-S POUR SYSTEME SUISSE DES MACHINES COULISSANTE AUTOMATIQUE
 S-SYSTEM TOOLS FOR SWISS TYPE SLIDING AUTOMATIC LATHES

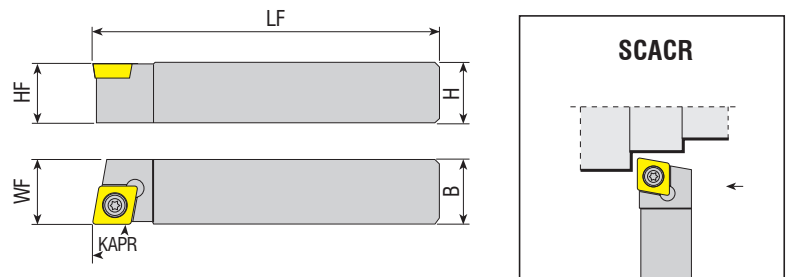

Código del Inserto Le Code de Commande Ordering Code	Stock Stock Stock	Dimension (mm) Dimension (mm) Dimension (mm)				Inserto Plaque Insert	Recambios / Pièces de Rechange / Spare Parts			
		R	L	HF=H	B		LF	WF	Tornillo Vis Screw	Cuñas Assise Shim
SCACR/L 0808 X06-S	● ●	08	08	115	08					
1010 K06-S	● ○	10	10	125	10					
1212 G06-S	● ○	12	12	90	12					
1212 K06-S	● ○	12	12	125	12					
1616 F06-S	○ ○	16	16	75	16					
1616 K06-S	○ ○	16	16	125	16					
1212 G09-S	○ ○	12	12	90	12					
1212 K09-S	● ●	12	12	125	12					
1616 F09-S	○ ○	16	16	75	16					
1616 K09-S	● ●	16	16	125	16					
2020 K09-S	● ●	20	20	125	20					

R: Derecha / Droite / Right L: Izquierda / Gauche / Left

● En Existencia / En stock / In Stock ○ Artículo sin Existencia / Indisponible en Stock / Non Stock Item

Ejemplo de Pedido / Exemple de Commande / Ordering Example

1 Piezas / pcs. / pcs. SVVCN 1212 F11

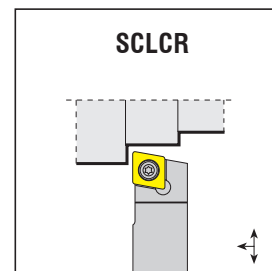
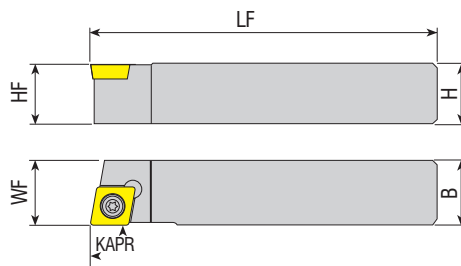

Código del Inserto Le Code de Commande Ordering Code		Stock Stock		Dimension (mm) Dimension (mm) Dimension (mm)			Inserto Plaquette Insert	Recambios / Pièces de Rechange / Spare Parts			
		R	L	HF=H	B	LF		WF	Tornillo Vis Screw	Cuñas Assise Shim	Tornillo de Placa Vis a Assise Shim Screw
SCLCR/L 0808 X06-S	● ●	08	08	115	08	CC.T 0602..					
1010 X06-S	● ○	10	10	115	10						
1212 G06-S	○ ○	12	12	90	12						
1212 X06-S	● ○	12	12	130	12						
1212 K06-S	○ ●	12	12	125	12						
1616 F06-S	● ○	16	16	75	16						
1616 X06-S	● ○	16	16	130	16						
1212 G09-S	● ●	12	12	90	12						
1212 X09-S	● ○	12	12	130	12						
1616 F09-S	● ○	16	16	75	16						
1616 G09-S	● ○	16	16	90	16						
1616 X09-S	● ○	16	16	115	16						
2020 X09-S	● ○	20	20	120	20						

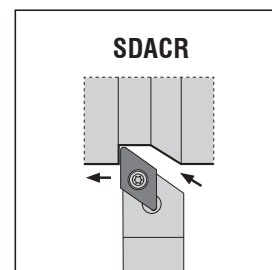
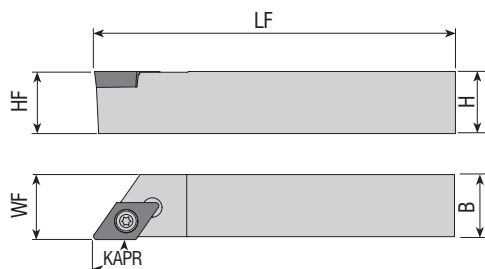

Código del Inserto Le Code de Commande Ordering Code		Stock Stock		Dimension (mm) Dimension (mm) Dimension (mm)			Inserto Plaquette Insert	Recambios / Pièces de Rechange / Spare Parts			
		R	L	HF=H	B	LF		WF	Tornillo Vis Screw	Cuñas Assise Shim	Tornillo de Placa Vis a Assise Shim Screw
SDACR/L 0808 X07-S	● ●	08	08	115	08	DC.T 0702..					
1010 K07-S	● ●	10	10	125	10						
1212 G07-S	○ ○	12	12	90	12						
1212 K07-S	● ●	12	12	125	12						
1616 F07-S	● ○	16	16	75	16						
1616 K07-S	● ●	16	16	125	16						
1212 G11-S	○ ○	12	12	90	12						
1212 K11-S	● ●	12	12	125	12						
1616 F11-S	● ○	16	16	75	16						
1616 K11-S	● ●	16	16	125	16						
2020 K11-S	● ●	20	20	125	20						

R: Derecha / Droite / Right L: Izquierda / Gauche / Left

● En Existencia / En stock / In Stock ○ Artículo sin Existencia / Indisponible en Stock / Non Stock Item

Ejemplo de Pedido / Exemple de Commande / Ordering Example

1 Piezas / pcs. / pcs. SCLCR 0808 X06-S

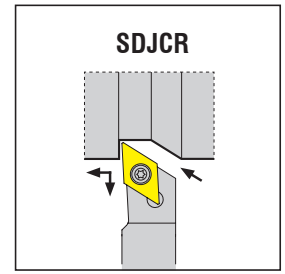
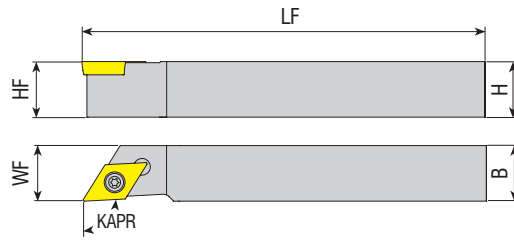
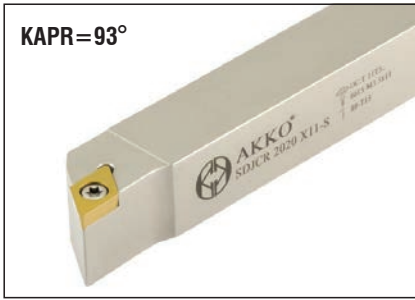

Código del Inserto Le Code de Commande Ordering Code	Stock						Inserto Plaquette Insert	Recambios / Pièces de Rechange / Spare Parts			
	Stock		Dimension (mm) Dimension (mm)					Tornillo Vis Screw	Cuñas Assise Shim	Tornillo de Placa Vis a Assise Shim Screw	Llave Torx Clé Torx Torx Wrench
	R	L	HF=H	B	LF	WF					
SDJCR/L 0808 X07-S	●	○	08	08	115	08					
1010 X07-S	●	●	10	10	115	10					
1212 G07-S	●	○	12	12	90	12					
1212 X07-S	●	●	12	12	130	12					
1616 F07-S	●	○	16	16	75	16					
1616 X07-S	●	○	16	16	130	16					
2020 X07-S	●	○	20	20	120	20					
1212 G11-S	●	○	12	12	90	12					
1212 X11-S	●	●	12	12	130	12					
1212 K11-S	●	●	12	12	125	12					
1616 F11-S	●	○	16	16	75	16					
1616 X11-S	●	●	16	16	130	16					
1616 K11-S	●	●	16	16	125	16					
2020 X11-S	●	○	20	20	120	20					

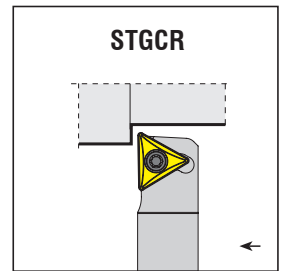
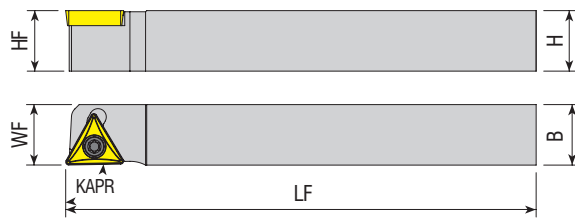

Código del Inserto Le Code de Commande Ordering Code	Stock						Inserto Plaquette Insert	Recambios / Pièces de Rechange / Spare Parts			
	Stock		Dimension (mm) Dimension (mm)					Tornillo Vis Screw	Cuñas Assise Shim	Tornillo de Placa Vis a Assise Shim Screw	Llave Torx Clé Torx Torx Wrench
	R	L	HF=H	B	LF	WF					
STGCR/L 1216 K11-S	●	○	12	16	125	16					
1616 K11-S	●	○	16	16	125	16					
1216 K16-S	●	○	12	16	125	16					
1616 K16-S	●	○	16	16	125	16					

R: Derecha / Droite / Right L: Izquierda / Gauche / Left

● En Existencia / En stock / In Stock ○ Artículo sin Existencia / Indisponible en Stock / Non Stock Item

Ejemplo de Pedido / Exemple de Commande / Ordering Example

1 Piezas / pcs. / pcs. SDJCR 0808 X07-S

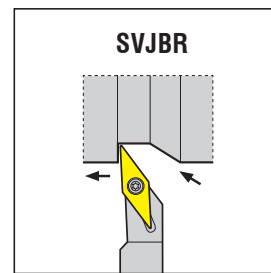
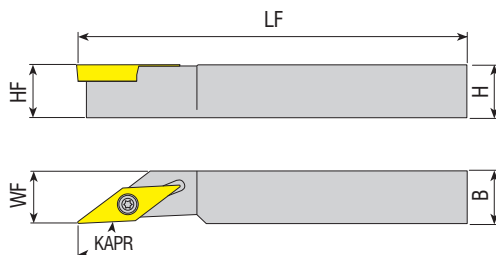

Código del Inserto Le Code de Commande Ordering Code	Dimension (mm) Dimension (mm)						Inserto Plaquette Insert	Recambios / Pièces de Rechange / Spare Parts			
	Stock Stock		HF=H	B	LF	WF		Tornillo Vis Screw	Cuñas Assise Shim	Tornillo de Placa Vis a Assise Shim Screw	Llave Torx Clé Torx Torx Wrench
	R	L									
SVJBR/L 1616 K11-S	●	●	16	16	125	16			-		

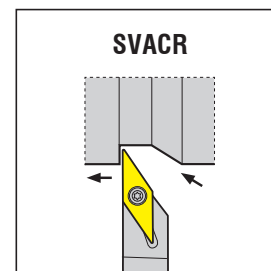
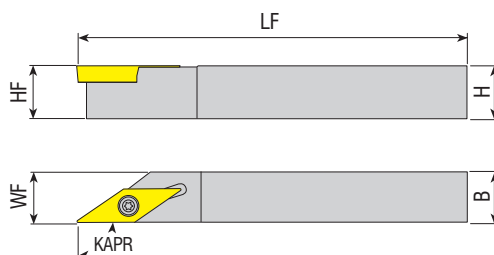

Código del Inserto Le Code de Commande Ordering Code	Dimension (mm) Dimension (mm)						Inserto Plaquette Insert	Recambios / Pièces de Rechange / Spare Parts			
	Stock Stock		HF=H	B	LF	WF		Tornillo Vis Screw	Cuñas Assise Shim	Tornillo de Placa Vis a Assise Shim Screw	Llave Torx Clé Torx Torx Wrench
	R	L									
SVACR/L 0808 X11-S	○	○	08	08	115	08			-		
1010 K11-S	●	○	10	10	125	10					
1212 G11-S	○	○	12	12	90	12					
1212 K11-S	●	●	12	12	125	12					
1616 F11-S	○	○	16	16	75	16					
1616 K11-S	●	●	16	16	125	16					
2020 K11-S	●	●	20	20	125	20					
1212 K16-S	●	●	12	12	125	12			-		
1616 K16-S	●	●	16	16	125	16					

R: Derecha / Droite / Right L: Izquierda / Gauche / Left
 ● En Existencia / En stock / In Stock ○ Artículo sin Existencia / Indisponible en Stock / Non Stock Item

Ejemplo de Pedido / Exemple de Commande / Ordering Example
 1 Piezas / pcs. / pcs. SVJBR 1616 K11-S

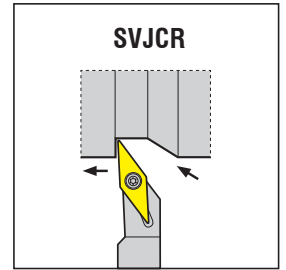
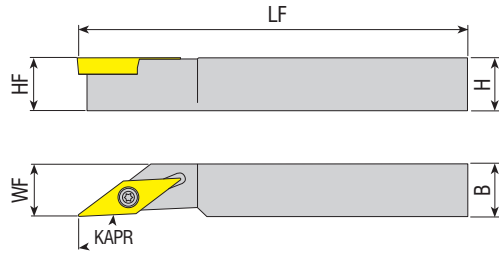

Código del Inserto Le Code de Commande Ordering Code	Dimension (mm) Dimension (mm) Dimension (mm)						Inserto Plaquette Insert	Recambios / Pièces de Rechange / Spare Parts			
	Stock Stock Stock		HF=H	B	LF	WF		Tornillo Vis Screw	Cuñas Assise Shim	Tornillo de Placa Vis a Assise Shim Screw	Llave Torx Clé Torx Torx Wrench
	R	L									
SVJCR/L 0808 X11-S	●	○	08	08	115	08	VC.T 1103..	4008-M2.5x6	-	-	80-T08
1010 K11-S	●	○	10	10	125	10					
1212 G11-S	○	○	12	12	90	12					
1212 K11-S	●	●	12	12	125	12					
1616 F11-S	○	○	16	16	75	16					
1616 K11-S	●	○	16	16	125	16					
2020 K11-S	○	○	20	20	125	20					

HERRAMIENTAS SEC
 OUTILS SEC
 SEC TOOLS

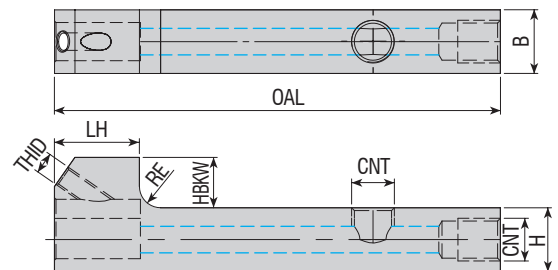

Código del Inserto Le Code de Commande Ordering Code	Dimension (mm) Dimension (mm) Dimension (mm)										Recambios / Pièces de Rechange / Spare Parts		
	Stock Stock Stock		H	B	RE	HBKW	LH	OAL	CNT	THID	Gewindestift umut Threaded Pin	Tornillo de Fijación Vis de Fixation Mounting Screw	Llaves Allen Clés Allen Allen Wrench
ASTB-1212-L84-H	●		12	12	4	9.5	16	84	M8X1X5	M4x0.7	2704-M8X1X5	2503-M4x12-C	AAL-03-3
ASTB-1616-L90-H	●		16	16	1	5.5	16	90	M8X1X5	M4x0.7			

R: Derecha / Droite / Right L: Izquierda / Gauche / Left

● En Existencia / En stock / In Stock ○ Artículo sin Existencia / Indisponible en Stock / Non Stock Item

Ejemplo de Pedido / Exemple de Commande / Ordering Example

1 Piezas / pcs. / pcs. SVJCR 0808 X11-S



KAPR=93°

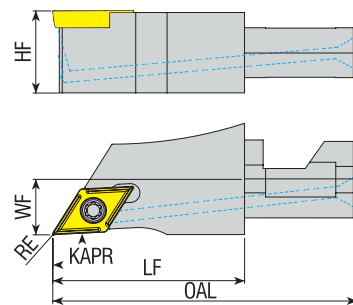

Código del Inserto
Le Code de Commande
Ordering Code

Stock
Stock
Stock

Dimension (mm)
Dimension (mm)
Dimension (mm)

Inserto
Plaquette
Insert

Recambios / Pièces de Rechange / Spare Parts

Tornillo
Vis
Screw

Llave Torx
Clé Torx
Torx Wrench

R

L

HF

WF

RE

LF

OAL



SDJCR/L-12X43.3-07

●

●

11.8

8

0.2

27.3

43.3

12X43.3-07-H

●

●

11.8

8

0.2

27.3

43.3

16X43.3-07

●

●

15.8

8

0.2

27.3

43.3

16X43.3-07-H

●

●

15.8

8

0.2

27.3

43.3

12X43.3-11

●

●

11.8

8

0.2

27.3

43.3

12X43.3-11-H

●

●

11.8

8

0.2

27.3

43.3

16X43.3-11

●

●

15.8

8

0.2

27.3

43.3

16X43.3-11-H

●

●

15.8

8

0.2

27.3

43.3

DC.T 070202

4008-M2.5x6

80-T08

DC.T 11T302

4015-M3.5x9

80-T15



KAPR=93°

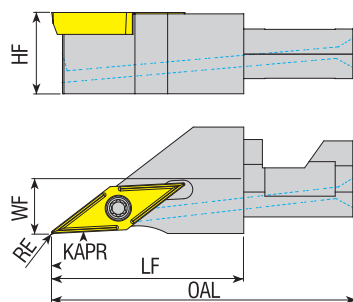

Código del Inserto
Le Code de Commande
Ordering Code

Stock
Stock
Stock

Dimension (mm)
Dimension (mm)
Dimension (mm)

Inserto
Plaquette
Insert

Recambios / Pièces de Rechange / Spare Parts

Tornillo
Vis
Screw

Llave Torx
Clé Torx
Torx Wrench

R

L

HF

WF

RE

LF

OAL



SVJCR/L-12X43.3-11

●

●

11.8

8

0.2

27.3

43.3

12X43.3-11-H

●

●

11.8

8

0.2

27.3

43.3

16X43.3-11

●

●

15.8

8

0.2

27.3

43.3

16X43.3-11-H

●

●

15.8

8

0.2

27.3

43.3

VC.T 110302

4008-M2.5x6

80-T08

R: Derecha / Droite / Right L: Izquierda / Gauche / Left

● En Existencia / En stock / In Stock ○ Artículo sin Existencia / Indisponible en Stock / Non Stock Item

Ejemplo de Pedido / Exemple de Commande / Ordering Example

1 Piezas / pcs. / pcs. SDJCR-12X43.3-07

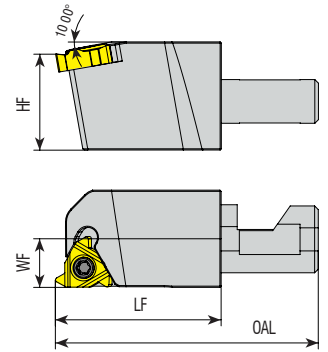

Código del Inserto
Le Code de Commande
Ordering Code

Stock Stock		Dimension (mm) Dimension (mm)					Inserto Plaquelette Insert	Tornillo Vis Screw	Cuña Derecha Assise Droite Right Shim	Cuña Izquierda Assise Gauche Left Shim	Tornillo de Placa Vis a Assise Shim Screw	Anillo de Tornillo de Cuña Assise Bague à Vis Shim Screw Ring	Llave Torx Clé Torx Torx Wrench
R	L	OAL	LF	WF	HF								
●	●	43.3	27.3	8	11.8			-	-	-	-	80-T08	
●	●	43.3	27.3	8	15.8	11 ER/EL	4008-M2.5x6	-	-	-	-	80-T08	
●	●	43.3	27.3	8	15.8	16 ER/EL	1710-U5-40x12.2	ATS-16E	ATS-16I	AAV-11-U5-40x4.5	ABPL-03	80-T10	



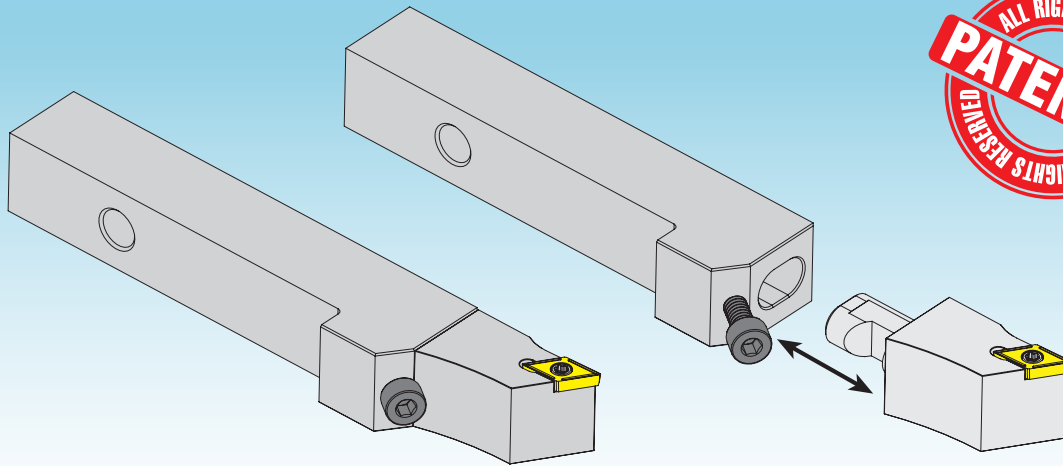

Cambio rápido, sin tener que quitar el portaherramientas de la banda!

Changement rapide, sans avoir à retirer le porte-outil de la bande!

Quick change, without having to remove the tool-holder from the gang !

El preajuste es posible fuera de la máquina.

Prépositionnement est possible en dehors de la machine.

Presetting is possible outside of the machine.

Ajuste ultra preciso.

Montage ultra précis.

Ultra precise fitting.

Fijación rígida.

Fixation rigide.

Rigid fixation.

Portaherramientas Sección: 12x12 y 16x16 mm..

Section porte-outil: 12x12 et 16x16 mm.

Tool-holder section : 12x12 and 16x16 mm.

Insertos izquierdo y derecho disponibles.

À gauche et à droite plaquettes disponibles.

Left and right inserts available.

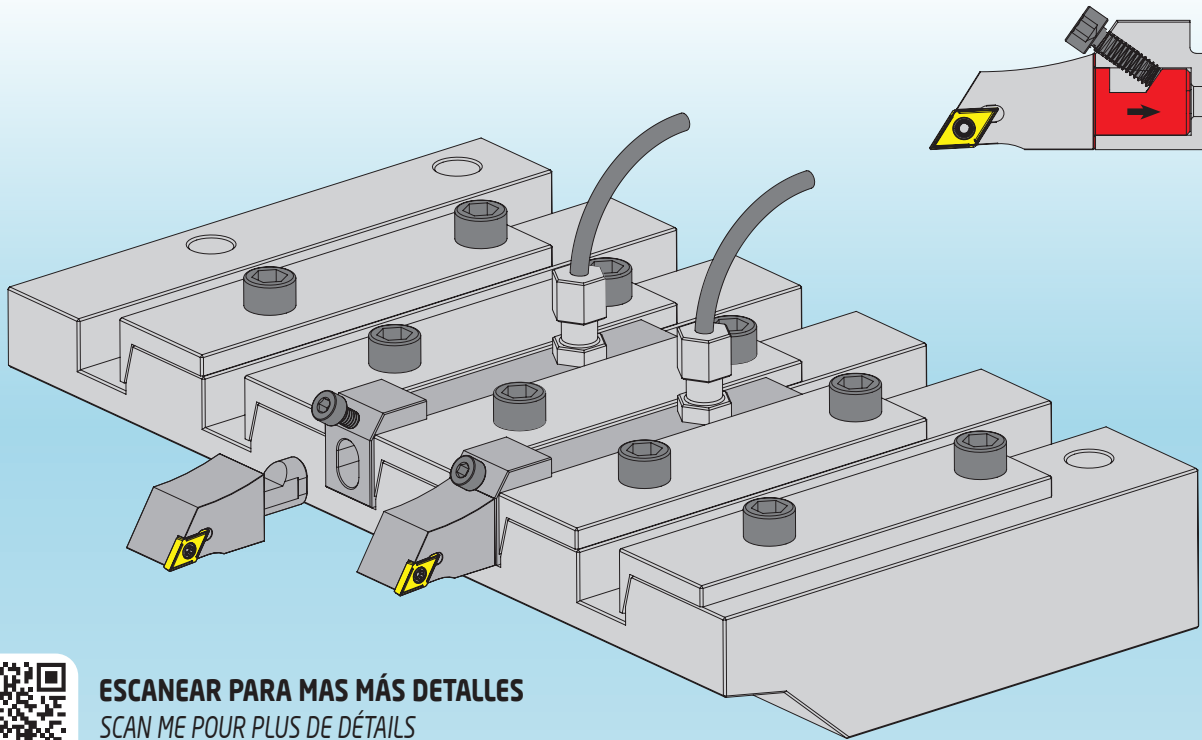

ESCANEAR PARA MAS MÁS DETALLES
 SCAN ME POUR PLUS DE DÉTAILS
 SCAN ME FOR MORE DETAILS

PORTA HERRAMIENTAS DE TORNEADO INTERNO
PORTE-OUTILS DE TOURNAGE Interieur
INTERNAL TURNING TOOLHOLDERS



S 25 S P C L N R 12 C

1 V
 "A" Acero sólido con orificio de refrigerante / "A" En acier massif avec trou d'arrosage
 "A" Solid steel with coolant hole
 Barra de carburo "E" con cabezal de acero fijo y orificio de refrigerante / "E" Avec barre Carbide tête fixe en acier et un trou de fluide de refroidissement
 "E" Carbide bar with fixed steel head and coolant hole
 "C" Mango de carburo / "C" Tige Carbide / "C" Carbide shank
 "S" Vástago de acero / "S" Tige en acier / "S" Steel shank

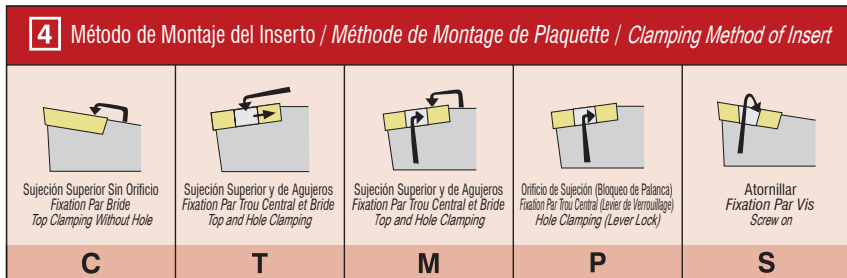
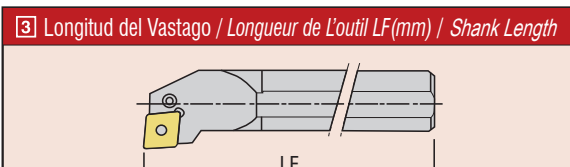

A - 32	H - 100	Q - 180	x-special
B - 40	J - 110	R - 200	
C - 50	K - 125	S - 250	
D - 60	L - 140	T - 300	
E - 70	M - 150	U - 350	
F - 80	N - 160	V - 400	
G - 90	P - 170	W - 450	

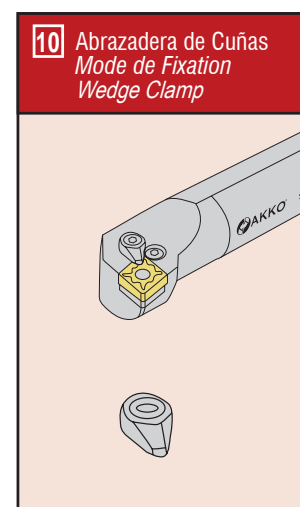
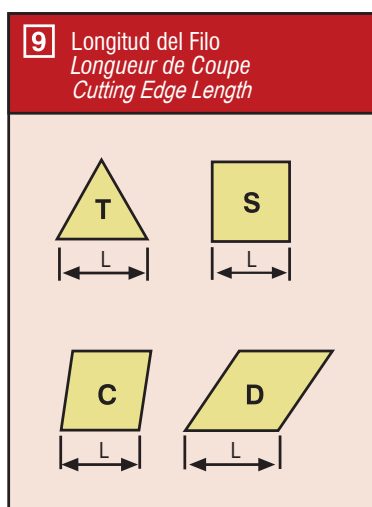
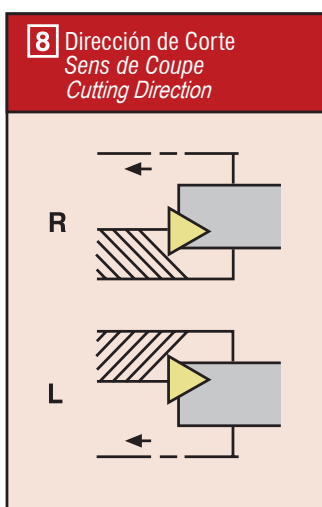
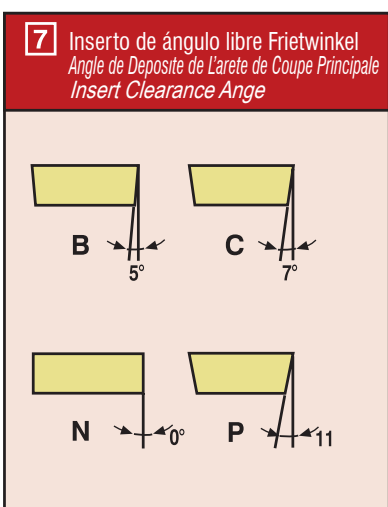
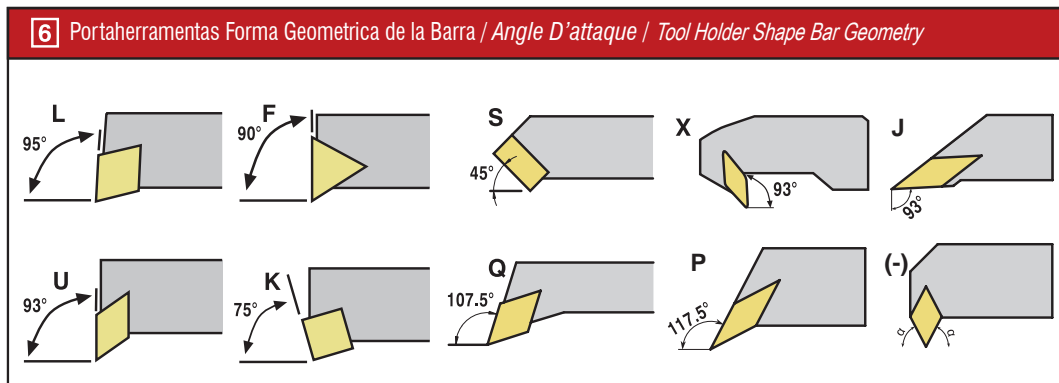
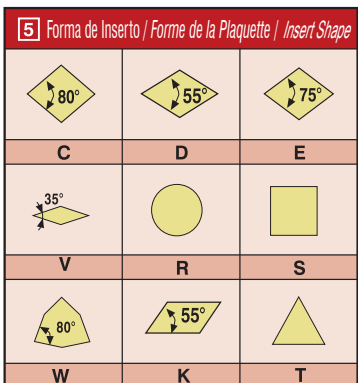



T&C-SYSTEM

BARRAS DE MANDRINAR SISTEMA T&C
BARRES DE D'ALESAGE SYSTÈME T&C
T&C SYSTEM BORING BARS

konusulan
the spoken kalite...
quality...



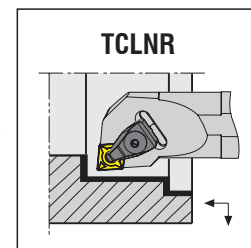
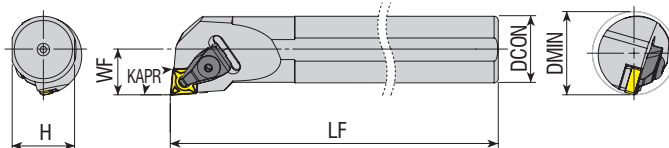

Código del Inserto Le Code de Commande Ordering Code	Dimension (mm) Dimension (mm)							Inserto Plaquette Insert	Recambios / Pièces de Rechange / Spare Parts						
	Stock Stock		DCON	H	LF	WF	DMIN		Atrazadera de Cuñas Mode de Fixation Wedge Clamp	Tomillo de Sujeción Vis de Fixation Wedge Screw	Cuñas Assise Shim	Tomillo de Placa Vis a Assise Shim Screw	Anillo Bague Ring	Arandela Timbre Washer	Llaves Allen Clés Allen Allen Wrench
	R	L							ATK-01	AKV-01-M5x22	AACN-2-0001	AAV-09-M5x9	-		
S25S TCLNR/L 09	●●		25	23	250	17	≥32	CNM. 0903..	ATK-01	AKV-01-M5x22	AACN-2-0001	AAV-09-M5x9	-		
S25S TCLNR/L 12	●●		25	23	250	17	≥32				AAV-13-M5x8				
S32T TCLNR/L 12	●●		32	30	300	22	≥40	CNM. 1204..	ATK-02	AKV-30-M6x22	AACN-3-0001	AAV-02-M5x12	AS-01	ABPL-01	AAL-03-3
S40U TCLNR/L 12	●●		40	37.5	350	27	≥50								
S50V TCLNR/L 12	●●		50	47	400	35	≥63								
S32T TCLNR/L 16	●●		32	30	300	22	≥40								
S40U TCLNR/L 16	●●		40	37.5	350	27	≥50	CNM. 1606..	ATK-04	AKV-19-M7x25	AACN-3-0002	AAV-05-M6x15	AS-02	ABPL-02	AAL-05-4
S50V TCLNR/L 16	●●		50	47	400	35	≥63								

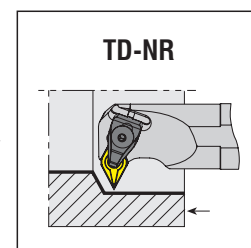
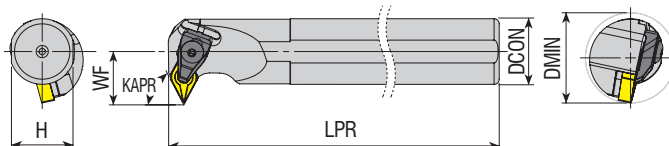

Código del Inserto Le Code de Commande Ordering Code	Dimension (mm) Dimension (mm)							Inserto Plaquette Insert	Recambios / Pièces de Rechange / Spare Parts						
	Stock Stock		DCON	H	LPR	WF	DMIN		Atrazadera de Cuñas Mode de Fixation Wedge Clamp	Tomillo de Sujeción Vis de Fixation Wedge Screw	Cuñas Assise Shim	Tomillo de Placa Vis a Assise Shim Screw	Anillo Bague Ring	Arandela Timbre Washer	Llaves Allen Clés Allen Allen Wrench
	R	L							ATK-02	AKV-30-M6x22	AADN-3-0001	AAV-02-M5x12	AS-01 <td>ABPL-01</td> <td>AAL-03-3</td>	ABPL-01	AAL-03-3
S32T TD-NR/L 15	●●		32	30	300	26	≥44								
S40U TD-NR/L 15	●●		40	37.5	350	29	≥52	DNM. 1506..	ATK-02	AKV-30-M6x22	AADN-3-0001	AAV-02-M5x12	AS-01	ABPL-01	AAL-03-3
S50V TD-NR/L 15	●●		50	47	400	35	≥63								

R: Derecha / Droite / Right L: Izquierda / Gauche / Left

● En Existencia / En stock / In Stock ○ Artículo sin Existencia / Indisponible en Stock / Non Stock Item

Ejemplo de Pedido / Exemple de Commande / Ordering Example

1 Piezas / pcs. / pcs. S25S TCLNR 09

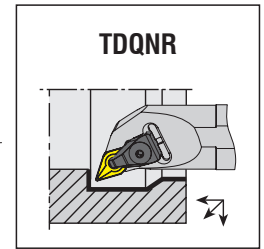
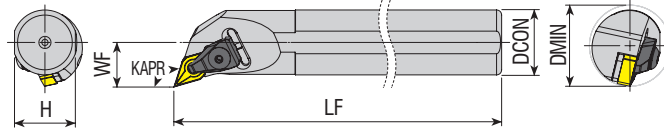

Código del Inserto Le Code de Commande Ordering Code	Dimension (mm) Dimension (mm)							Inserto Plaquette Insert	Recambios / Pièces de Rechange / Spare Parts						
	Stock Stock		DCON	H	LF	WF	DMIN		Abrazadera de Cuñas Mode de Fixation Wedge Clamp	Tornillo de Sujeción Vis de Fixation Wedge Screw	Cuñas Assise Shim	Tornillo de Placa Vis a Assise Shim Screw	Anillo Bague Ring	Arandela Timbre Washer	Llaves Allen Cles Allen Allen Wrench
	R	L													
S25S TDQNR/L 11	●	●	25	23	250	17	≥32	DNM. 1104..	ATK-01	AKV-01-M5x22	AADN-2-0001	AAV-09-M5x9	-	ABPL-01	AAL-03-3
S32T TDQNR/L 11	●	●	32	30	300	22	≥40					AAV-04-M5x12			
S25S TDQNR/L 15	●	●	25	23	250	17	≥32	DNM. 1506..	ATK-02	AKV-30-M6x22	AADN-3-0001	AAV-13-M5x8	AS-01	ABPL-01	AAL-03-3
S32T TDQNR/L 15	●	●	32	30	300	22	≥40					AAV-02-M5x12			
S40U TDQNR/L 15	●	●	40	37.5	350	27	≥50								
S50V TDQNR/L 15	●	●	50	47	400	35	≥63								

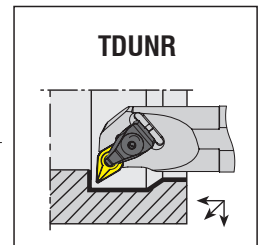
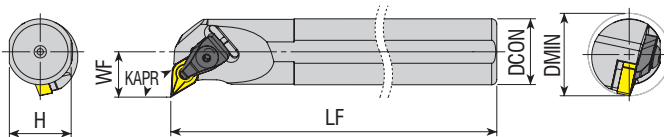

Código del Inserto Le Code de Commande Ordering Code	Dimension (mm) Dimension (mm)							Inserto Plaquette Insert	Recambios / Pièces de Rechange / Spare Parts						
	Stock Stock		DCON	H	LF	WF	DMIN		Abrazadera de Cuñas Mode de Fixation Wedge Clamp	Tornillo de Sujeción Vis de Fixation Wedge Screw	Cuñas Assise Shim	Tornillo de Placa Vis a Assise Shim Screw	Anillo Bague Ring	Arandela Timbre Washer	Llaves Allen Cles Allen Allen Wrench
	R	L													
S25S TDUNR/L 11	●	●	25	23	250	17	≥32	DNM. 1104..	ATK-01	AKV-01-M5x22	AADN-2-0001	AAV-09-M5x9	-	ABPL-01	AAL-03-3
S32T TDUNR/L 11	●	●	32	30	300	22	≥40					AAV-04-M5x12			
S25S TDUNR/L 15	●	●	25	23	250	17	≥34	DNM. 1506..	ATK-02	AKV-30-M6x22	AADN-3-0001	AAV-13-M5x8	AS-01	ABPL-01	AAL-03-3
S32T TDUNR/L 15	●	●	32	30	300	22	≥40					AAV-02-M5x12			
S40U TDUNR/L 15	●	●	40	37.5	350	27	≥50								
S50V TDUNR/L 15	●	●	50	47	400	35	≥63								

R: Derecha / Droite / Right L: Izquierda / Gauche / Left

● En Existencia / En stock / In Stock ○ Artículo sin Existencia / Indisponible en Stock / Non Stock Item

Ejemplo de Pedido / Exemple de Commande / Ordering Example

1 Piezas / pcs. / pcs. S25S TDQNR 11

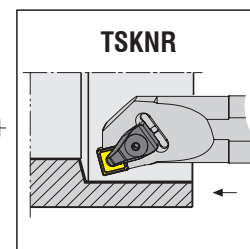
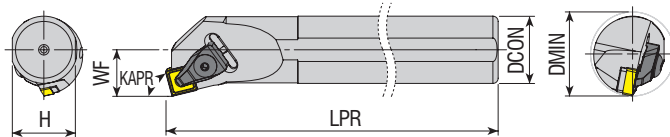

Código del Inserto Le Code de Commande Ordering Code	Dimension (mm) Dimension (mm)								Inserto Plaquette Insert	Recambios / Pièces de Rechange / Spare Parts							
	Stock Stock		R	L	DCON	H	LPR	WF		DMIN	Abrazadera de Cuñas Mode de Fixation Wedge Clamp	Tornillo de Sujeción Vis de Fixation Wedge Screw	Cuñas Assise Shim	Tornillo de Placa Vis a Assise Shim Screw	Anillo Bague Ring	Arandela Timbre Washer	Llaves Allen Cles Allen Allen Wrench
S25S TSKNR/L 12	●	●			25	23	250	17	≥32	SNM. 1204..	ATK-02	AKV-30-M6x22	AASN-3-0004	AAV-13-M5x8	AS-01	ABPL-01	AAL-03-3
S32T TSKNR/L 12	●	●			32	30	300	22	≥40								
S40U TSKNR/L 12	●	●			40	37.5	350	27	≥50								

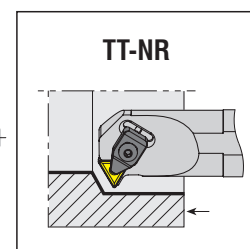
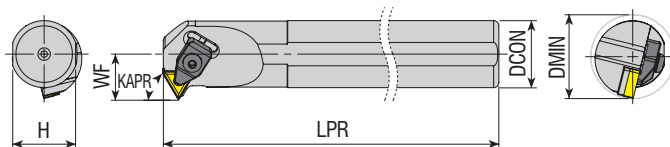

Código del Inserto Le Code de Commande Ordering Code	Dimension (mm) Dimension (mm)								Inserto Plaquette Insert	Recambios / Pièces de Rechange / Spare Parts							
	Stock Stock		R	L	DCON	H	LPR	WF		DMIN	Abrazadera de Cuñas Mode de Fixation Wedge Clamp	Tornillo de Sujeción Vis de Fixation Wedge Screw	Cuñas Assise Shim	Tornillo de Placa Vis a Assise Shim Screw	Resorte Printemps Spring	Arandela Timbre Washer	Llaves Allen Cles Allen Allen Wrench
S25S TT-NR/L 16	●	●			25	23	250	17	≥32	TNM. 1604..	ATK-01	AKV-01-M5x22	AATN-2-0002	AAV-03-M5x12	-	ABPL-01	AAL-03-3
S32T TT-NR/L 16	●	●			32	30	300	22	≥40								

R: Derecha / Droite / Right L: Izquierda / Gauche / Left

● En Existencia / En stock / In Stock ○ Artículo sin Existencia / Indisponible en Stock / Non Stock Item

Ejemplo de Pedido / Exemple de Commande / Ordering Example

1 Piezas / pcs. / pcs. S25S TSKNR 12

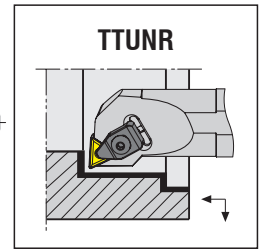
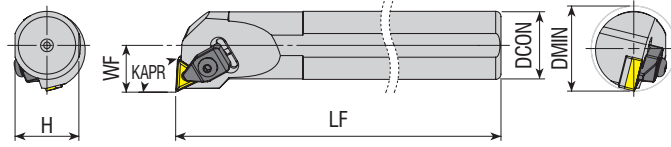
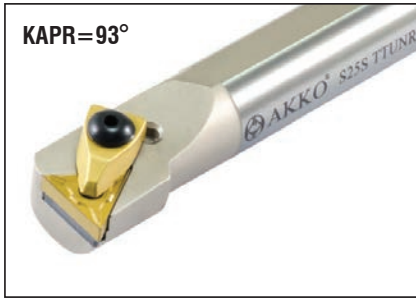

Código del Inserto Le Code de Commande Ordering Code	Stock		Dimension (mm) Dimension (mm) Dimension (mm)					Inserto Plaquette Insert	Recambios / Pièces de Rechange / Spare Parts						
	R	L	DCON	H	LF	WF	DMIN		Abrazadera de Cuñas Mode de Fixation Wedge Clamp	Tornillo de Sujeción Vis de Fixation Wedge Screw	Cuñas Assise Shim	Tornillo de Placa Vis a Assise Shim Screw	Anillo Bague Ring	Arandela Timbre Washer	Llaves Allen Clés Allen Allen Wrench
	S25S TTUNR/L 16	●	●	25	23	250	17	≥32	TNM. 1604..	ATK-01	AKV-01-M5x22	AATN -2-0002	AAV-03-M5x12	-	ABPL-01
S32T TTUNR/L 16	●	●	32	30	300	22	≥40								
S25S TTUNR/L 22	●	●	25	23	250	17	≥32	TNM. 2204..	ATK-02	AKV-30-M6x22	AATN -3-0015	AAV-02-M5x12	AS-01	ABPL-01	AAL-03-3
S32T TTUNR/L 22	●	●	32	30	300	22	≥40								
S40U TTUNR/L 22	●	●	40	37.5	350	27	≥50								
S50V TTUNR/L 22	●	●	50	47	400	35	≥63								

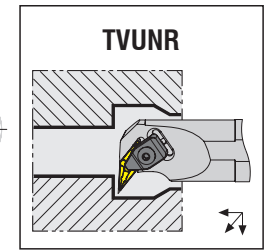
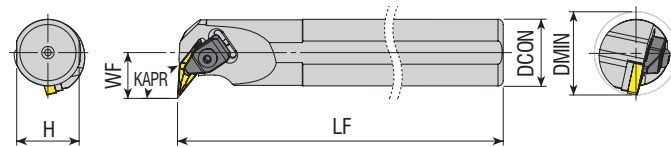

Código del Inserto Le Code de Commande Ordering Code	Stock		Dimension (mm) Dimension (mm) Dimension (mm)					Inserto Plaquette Insert	Recambios / Pièces de Rechange / Spare Parts						
	R	L	DCON	H	LF	WF	DMIN		Abrazadera de Cuñas Mode de Fixation Wedge Clamp	Tornillo de Sujeción Vis de Fixation Wedge Screw	Cuñas Assise Shim	Tornillo de Placa Vis a Assise Shim Screw	Resorte Printemps Spring	Arandela Timbre Washer	Llaves Allen Clés Allen Allen Wrench
	S25S TVUNR/L 16	●	●	25	23	250	20	≥36	VNM. 1604..	ATK-01	AKV-01-M5x22	AAVN -2-0002	AAV-04-M5x12	-	ABPL-01
S32T TVUNR/L 16	●	●	32	30	300	22	≥40								
S40U TVUNR/L 16	●	●	40	37.5	350	27	≥50								

R: Derecha / Droite / Right L: Izquierda / Gauche / Left
 ● En Existencia / En stock / In Stock ○ Artículo sin Existencia / Indisponible en Stock / Non Stock Item
 Ejemplo de Pedido / Exemple de Commande / Ordering Example
 1 Piezas / pcs. / pcs. S25S TTUNR 16

BARRAS DE MANDRINAR SISTEMA T
BARRES DE D'ALEPAGE SYSTEME T
T-SYSTEM BORING BARS

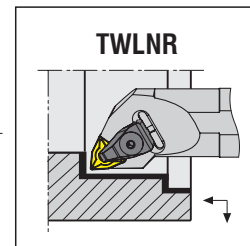
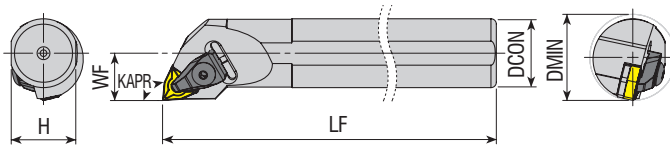

Código del Inserto
Le Code de Commande
Ordering Code

Recambios / Pièces de Rechange / Spare Parts

Código del Inserto Le Code de Commande Ordering Code	Stock		Dimension (mm) Dimension (mm)					Inserto Plaquette Insert	Abrazadera de Cuñas Mode de Fixation Wedge Clamp	Tornillo de Sujeción Vis de Fixation Wedge Screw	Cuñas Assise Shim	Tornillo de Placa Vis a Assise Shim Screw	Anillo Bague Ring	Arandela Timbre Washer	Llaves Allen Clés Allen Allen Wrench
	R	L	DCON	H	LF	WF	DMIN								
S25S TWLNR/L 06	●	●	25	23	250	17	≥32	WNM. 0604..	ATK-01	AKV-01-M5x22	AAWN-SW317	AAV-01-M3x10	-		
S32T TWLNR/L 06	●	●	32	30	300	22	≥40					AAV-13-M5x8			
S25S TWLNR/L 08	●	●	25	23	250	17	≥32	WNM. 0804..	ATK-02	AKV-30-M6x22	AAWN-3-0001	AAV-02-M5x12	AS-01	ABPL-01	AAL-03-3
S32T TWLNR/L 08	●	●	32	30	300	22	≥40								
S40U TWLNR/L 08	●	●	40	37.5	350	27	≥50								
S50V TWLNR/L 08	●	●	50	47	400	35	≥63								
A40T TWLNR/L 08	●	○	40	37.5	300	27	≥50								
A50U TWLNR/L 08	●	○	50	47	350	35	≥63								

BARRAS DE MANDRINAR SISTEMA C
BARRES DE D'ALEPAGE SYSTEME C
C-SYSTEM BORING BARS

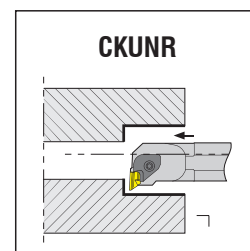
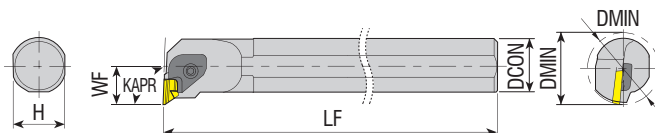

Código del Inserto
Le Code de Commande
Ordering Code

Recambios / Pièces de Rechange / Spare Parts

Código del Inserto Le Code de Commande Ordering Code	Stock		Dimension (mm) Dimension (mm)					Inserto Plaquette Insert	Abrazadera de Cuñas Mode de Fixation Wedge Clamp	Tornillo de Sujeción Vis de Fixation Wedge Screw	Cuñas Assise Shim	Tornillo de Placa Vis a Assise Shim Screw	Resorte Printemps Spring	Arandela Timbre Washer	Llaves Allen Clés Allen Allen Wrench
	R	L	DCON	H	LF	WF	DMIN								
S25S CKUNR/L 16	●	●	25	23	250	19	≥38	KNUX 1604..	ACK-01-R ACK-02-L	AKV-06-M6x20	AKS-16-R AKS-16-L	AAV-01-M3x10	AKY-02	ABPL-01	AAL-05-4
S32T CKUNR/L 16	●	●	32	30	300	22	≥40								
S40U CKUNR/L 16	●	●	40	37.5	350	27	≥50								
S50V CKUNR/L 16	●	●	50	47	400	35	≥63								

R: Derecha / Droite / Right L: Izquierda / Gauche / Left

● En Existencia / En stock / In Stock ○ Artículo sin Existencia / Indisponible en Stock / Non Stock Item

Ejemplo de Pedido / Exemple de Commande / Ordering Example

1 Piezas / pcs. / pcs. S25S TWLNR 06



M-SYSTEM

BARRAS DE MANDRINAR SISTEMA M
BARRES DE D'ALEPAGE SYSTÈME M
M-SYSTEM BORING BARS

konusulan
the spoken kalite...
quality...



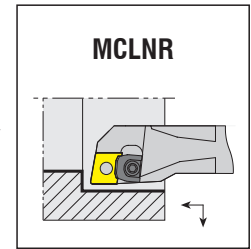
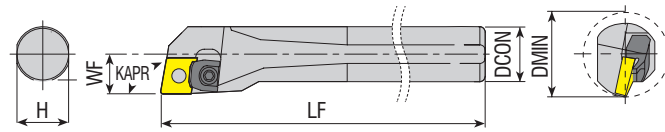

Código del Inserto Le Code de Commande Ordering Code	Dimension (mm) Dimension (mm)							Recambios / Pièces de Rechange / Spare Parts								
	Stock Stock		DCON	H	LF	WF	DMIN	Inserto Plaquette Insert	Abrazadera de Cuñas Mode de Fixation Wedge Clamp	Tornillo de Sujeción Vis de Fixation Wedge Screw	Cuñas Assise Shim	Pin Épingle Pin	Arandela Timbre Washer	Llaves Allen Clés Allen Allen Wrench		
	R	L														
S20R MCLNR/L 12	●	●	20	18.3	200	13	≥25	CNM. 1204..	AMK-07	AKV-04-M5x17	-	APM-12	-	AAL-03-3		
S25S MCLNR/L 12	●	●	25	23	250	17	≥32					AMK-03			AACN-3-0001	APM-13
S32T MCLNR/L 12	●	●	32	30	300	22	≥40									APM-04

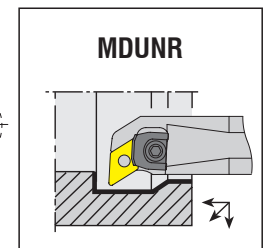
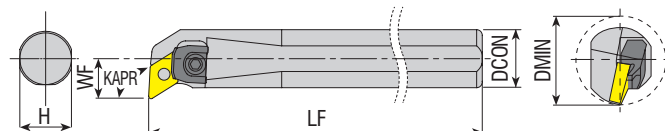

Código del Inserto Le Code de Commande Ordering Code	Dimension (mm) Dimension (mm)							Recambios / Pièces de Rechange / Spare Parts								
	Stock Stock		DCON	H	LF	WF	DMIN	Inserto Plaquette Insert	Abrazadera de Cuñas Mode de Fixation Wedge Clamp	Tornillo de Sujeción Vis de Fixation Wedge Screw	Cuñas Assise Shim	Pin Épingle Pin	Anillo Bague Ring	Arandela Timbre Washer	Llaves Allen Clés Allen Allen Wrench	
	R	L														
S20R MDUNR/L 11	●	●	20	18.3	200	13	≥25	DNM. 1104..	AMK-03	AKV-17-M5x15	-	APM-03	-	-	AAL-03-3	
S25S MDUNR/L 11	●	●	25	23	250	17	≥32			AMK-03						AKV-04-M5x17
S32T MDUNR/L 11	○	○	32	30	300	22	≥40									
S25S MDUNR/L 15	●	●	25	23	250	17	≥32	DNM. 1506..	AMK-04	AKV-20-M6x19	AADN-3-0001	APM-04	AS-01	ABPL-01		
S32T MDUNR/L 15	●	●	32	30	300	22	≥40									
S40U MDUNR/L 15	●	●	40	37.5	350	27	≥50									
S50V MDUNR/L 15	●	●	50	47	400	35	≥63									

R: Derecha / Droite / Right L: Izquierda / Gauche / Left

● En Existencia / En stock / In Stock ○ Artículo sin Existencia / Indisponible en Stock / Non Stock Item

Ejemplo de Pedido / Exemple de Commande / Ordering Example

1 Piezas / pcs. / pcs. S20R MCLNR 12

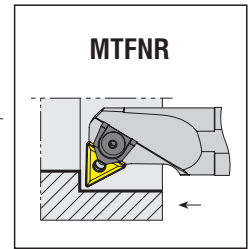
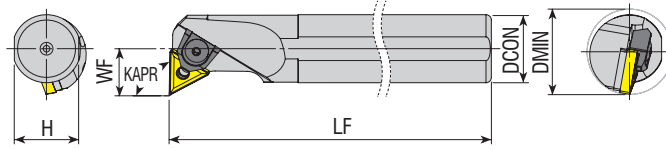

Código del Inserto Le Code de Commande Ordering Code	Recambios / Pièces de Rechange / Spare Parts														
	Stock Stock		Dimension (mm) Dimension (mm)				Inserto Plaquette Insert	Abrazadera de Cuñas Mode de Fixation Wedge Clamp	Tornillo de Sujeción Vis de Fixation Wedge Screw	Cuñas Assise Shim	Pin Épingle Pin	Anillo Bague Ring	Arandela Timbre Washer	Llaves Allen Clés Allen Allen Wrench	
	R	L	DCON	H	LF	WF	DMIN								
S20R MTFNR/L 16	●	●	20	18.3	200	14	≥25	TNM. 1604..	AMK-02	AKV-17-M5x15	-	APM-03	-	-	AAL-03-3
S25S MTFNR/L 16	●	●	25	23	250	17	≥32					APM-14			
S32T MTFNR/L 16	●	●	32	30	300	22	≥40				AATN-2-0002	APM-01	AS-01	ABPL-01	
S40U MTFNR/L 16	●	●	40	37.5	350	27	≥50		AMK-04	AKV-30-M6x22					
S32T MTFNR/L 22	●	●	32	30	300	22	≥40	TNM. 2204..							
S40U MTFNR/L 22	●	●	40	37.5	350	27	≥50				AATN-3-0015	APM-02			
S50V MTFNR/L 22	●	○	50	47	400	35	≥63								

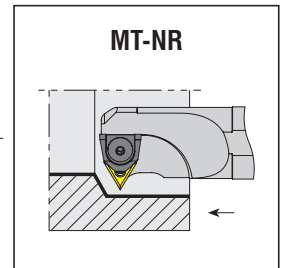
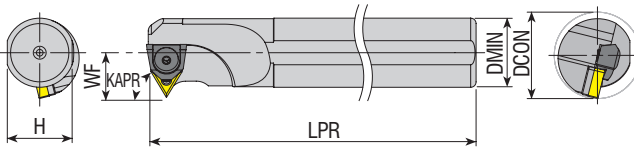

Código del Inserto Le Code de Commande Ordering Code	Recambios / Pièces de Rechange / Spare Parts														
	Stock Stock		Dimension (mm) Dimension (mm)				Inserto Plaquette Insert	Abrazadera de Cuñas Mode de Fixation Wedge Clamp	Tornillo de Sujeción Vis de Fixation Wedge Screw	Cuñas Assise Shim	Pin Épingle Pin	Anillo Bague Ring	Arandela Timbre Washer	Llaves Allen Clés Allen Allen Wrench	
	R	L	DCON	H	LPR	WF	DMIN								
S20R MT-NR/L 16	●	●	20	18.3	200	16	≥26	TNM. 1604..	AMK-02	AKV-04-M5x17	-	APM-03	-	-	AAL-03-3
S25S MT-NR/L 16	●	●	25	23	250	17	≥32					APM-14			
S32T MT-NR/L 16	●	●	32	30	300	22	≥40				AATN-2-0002	APM-01	AS-01	ABPL-01	
S40U MT-NR/L 16	●	●	40	37.5	350	27	≥50	TNM. 2204..							
S32T MT-NR/L 22	●	●	32	30	300	24	≥40		AMK-04	AKV-30-M6x22	AATN-3-0015	APM-02			
S40U MT-NR/L 22	●	●	40	37.5	350	27	≥50								
S50U MT-NR/L 22	●	●	50	47	350	35	≥63								

R: Derecha / Droite / Right L: Izquierda / Gauche / Left

● En Existencia / En stock / In Stock ○ Artículo sin Existencia / Indisponible en Stock / Non Stock Item

Ejemplo de Pedido / Exemple de Commande / Ordering Example

1 Piezas / pcs. / pcs. S20R MTFNR 16

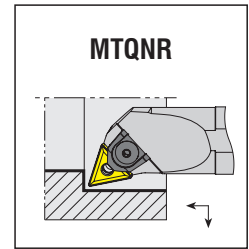
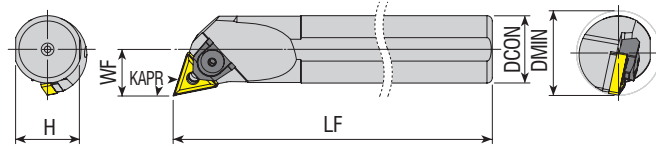

Código del Inserto Le Code de Commande Ordering Code	Recambios / Pièces de Rechange / Spare Parts														
	Stock Stock		Dimension (mm) Dimension (mm)				Inserto Plaquette Insert	Abrazadera de Cuñas Mode de Fixation Wedge Clamp	Tornillo de Sujeción Vis de Fixation Wedge Screw	Cuñas Assise Shim	Pin Épingle Pin	Anillo Bague Ring	Arandela Timbre Washer	Llaves Allen Clés Allen Allen Wrench	
	R	L	DCON	H	LF	WF	DMIN								
S20R MTQNR/L 16	●	●	20	18.3	200	13	≥25	TNM. 1604..	AMK-02	AKV-17-M5x15	-	APM-11	-	-	AAL-03-3
S25S MTQNR/L 16	●	●	25	23	250	17	≥32				AATN-2-0002	APM-14			
S32T MTQNR/L 16	●	●	32	30	300	22	≥40					APM-01			
S40U MTQNR/L 16	●	●	40	37.5	350	27	≥50						AS-01	ABPL-01	
S32T MTQNR/L 22	●	●	32	30	300	22	≥40	TNM. 2204..	AMK-04	AKV-30-M6x22					
S40U MTQNR/L 22	●	●	40	37.5	350	27	≥50				AATN-3-0015	APM-02			
S50V MTQNR/L 22	●	●	50	47	400	35	≥63								

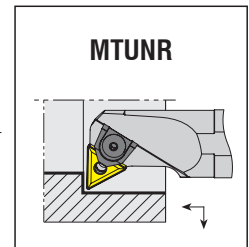
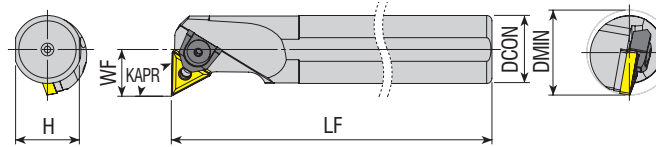

Código del Inserto Le Code de Commande Ordering Code	Recambios / Pièces de Rechange / Spare Parts														
	Stock Stock		Dimension (mm) Dimension (mm)				Inserto Plaquette Insert	Abrazadera de Cuñas Mode de Fixation Wedge Clamp	Tornillo de Sujeción Vis de Fixation Wedge Screw	Cuñas Assise Shim	Pin Épingle Pin	Anillo Bague Ring	Arandela Timbre Washer	Llaves Allen Clés Allen Allen Wrench	
	R	L	DCON	H	LF	WF	DMIN								
S20R MTUNR/L 16	●	●	20	18.3	200	13	≥25	TNM. 1604..	AMK-02	AKV-17-M5x15	-	APM-03	-	-	AAL-03-3
S25S MTUNR/L 16	●	●	25	23	250	17	≥32				AATN-2-0002	APM-14			
S32T MTUNR/L 16	●	●	32	30	300	22	≥40					APM-01			
S40U MTUNR/L 16	●	●	40	37.5	350	27	≥50						AS-01	ABPL-01	
S50V MTUNR/L 16	●	●	50	47	400	35	≥63	TNM. 2204..	AMK-04	AKV-30-M6x22					
S32T MTUNR/L 22	●	●	32	30	300	22	≥40				AATN-3-0015	APM-02			
S40U MTUNR/L 22	●	●	40	37.5	350	27	≥50								
S50V MTUNR/L 22	●	●	50	47	400	35	≥63								

R: Derecha / Droite / Right L: Izquierda / Gauche / Left

● En Existencia / En stock / In Stock ○ Artículo sin Existencia / Indisponible en Stock / Non Stock Item

Ejemplo de Pedido / Exemple de Commande / Ordering Example

1 Piezas / pcs. / pcs. S20R MTQNR 16

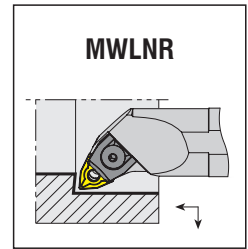
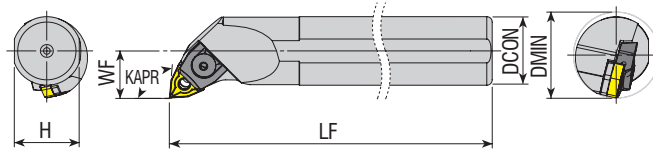

Código del Inserto Le Code de Commande Ordering Code	Stock		Dimension (mm) Dimension (mm)				Inserto Plaquette Insert	Abrazadera de Cuias Mode de Fixation Wedge Clamp	Tornillo de Sujeción Vis de Fixation Wedge Screw	Cuñas Assise Shim	Pin Épingle Pin	Anillo Bague Ring	Arandela Timbre Washer	Llaves Allen Clés Allen Allen Wrench				
	R	L	DCON	H	LF	WF									DMIN			
S16P MWLNR/L 06	●	●	16	14.8	170	11	≥20	WMM. 0604..	AMK-01	AKV-17-M5x15	-	APM-09	-	-	AAL-03-3			
S20R MWLNR/L 06	●	●	20	18.3	200	13	≥25					AKV-04-M5x17				APM-10		
S25S MWLNR/L 06	●	●	25	23	250	17	≥32					AKV-27-M6x20				APM-08		
S25S MWLNR/L 08	●	●	25	23	250	17	≥32					AKV-03-M6x22				APM-04		
S32T MWLNR/L 08	●	●	32	30	300	22	≥40					AAWN-3-0001				APM-02	AS-01	ABPL-01
S40U MWLNR/L 08	●	●	40	37.5	350	27	≥50											

R: Derecha / Droite / Right L: Izquierda / Gauche / Left

● En Existencia / En stock / In Stock ○ Artículo sin Existencia / Indisponible en Stock / Non Stock Item

Ejemplo de Pedido / Exemple de Commande / Ordering Example

1 Piezas / pcs. / pcs. S16P MWLNR 06





*konusulan
the spoken kalite...
quality...*

P-SYSTEM

BARRAS DE MANDRINAR SISTEMA P
BARRES DE D'ALEPAGE SYSTÈME P
P-SYSTEM BORING BARS



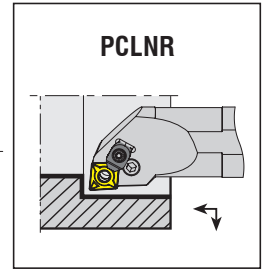
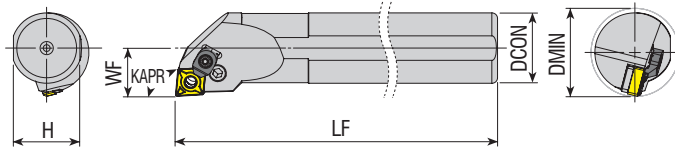

Código del Inserto Le Code de Commande Ordering Code	Stock Stock		Dimension (mm) Dimension (mm)					Inserto Plaquette Insert	Recambios / Pièces de Rechange / Spare Parts						
	R	L	DCON	H	LF	WF	DMIN		Palanca Lever	Tornillo de Palanca Lever Vis	Cuñas Assise Shim	Cuñas Resorte Ressort a Cale Shim Spring	Abrazadera de Cuñas Mode de Fixation Wedge Clamp	Tornillo de Sujecion Vis de Fixation Wedge Screw	Llaves Allen Clés Allen Allen Wrench
S16P PCLNR/L 09	●	●	16	14.8	170	11	≥20	CNM. 0903..	APL-07	ALV-07-M6x13	-	AAY-07	-	-	AAL-02-2.5
S20R PCLNR/L 09	●	●	20	18.3	200	13	≥25		APL-01	ALV-02-M6x17	AACN-2-0002	AAY-01	-	-	AAL-02-2.5
S25S PCLNR/L 09	●	○	25	23	250	17	≥32			ALV-08-M8x16					
S25S PCLNR/L 12C	●	●	25	23	250	17	≥32	CNM. 1204..	APL-02	ALV-03-M8x19	AACN-3-0001	AAY-02	ACK-05	4015-M4x11	AAL-03-3
S32T PCLNR/L 12C	●	●	32	30	300	22	≥40								
S40U PCLNR/L 12C	●	●	40	37.5	350	27	≥50								
S50V PCLNR/L 12C	●	●	50	47	400	35	≥63								
S32T PCLNR/L 16C	●	●	32	30	300	22	≥40	CNM. 1606..	APL-04	ALV-04-M8x22	AACN-3-0002	AAY-03	ACK-09	AAV-05-M6x15	
S40U PCLNR/L 16C	●	●	40	37.5	350	27	≥50								
S50V PCLNR/L 16C	●	●	50	47	400	35	≥63								
S40U PCLNR/L 19C	●	●	40	37.5	350	27	≥50	CNM. 1906..	APL-05	ALV-05-M10x27	AACN-3-0003	AAY-04	ACK-09	AAV-05-M6x15	AAL-05-4
S50V PCLNR/L 19C	●	●	50	47	400	35	≥63								
A20P PCLNR/L 09	●	●	20	18.3	170	13	≥25	CNM. 0903..	APL-01	ALV-02-M6x17	AACN-2-0002	AAY-01	-	-	AAL-02-2.5
A25R PCLNR/L 12C	●	●	25	23	200	17	≥32			ALV-08-M8x16					
A32S PCLNR/L 12C	●	●	32	30	250	22	≥40	CNM. 1204..	APL-02	ALV-03-M8x19	AACN-3-0001	AAY-02	ACK-05	4015-M4x11	AAL-03-3
A40T PCLNR/L 12C	●	●	40	37.5	300	27	≥50								
A50U PCLNR/L 12C	●	●	50	47	350	35	≥63								
A32S PCLNR/L 16C	●	●	32	30	250	22	≥40		CNM. 1606..	APL-04	ALV-04-M8x22	AACN-3-0002	AAY-03	ACK-09	AAV-05-M6x15
A40T PCLNR/L 16C	●	●	40	37.5	300	27	≥50								
A50U PCLNR/L 16C	●	●	50	47	350	35	≥63								
A40T PCLNR/L 19C	●	●	40	37.5	300	27	≥50	CNM. 1906..	APL-05	ALV-05-M10x27	AACN-3-0003	AAY-04	ACK-09	AAV-05-M6x15	AAL-05-4
A50U PCLNR/L 19C	●	●	50	47	350	35	≥63								

R: Derecha / Droite / Right L: Izquierda / Gauche / Left

● En Existencia / En stock / In Stock ○ Artículo sin Existencia / Indisponible en Stock / Non Stock Item

Ejemplo de Pedido / Exemple de Commande / Ordering Example

1 Piezas / pcs. / pcs. S16P PCLNR 09

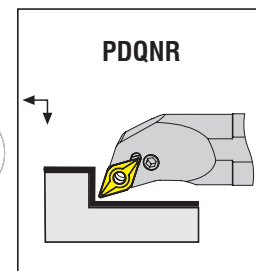
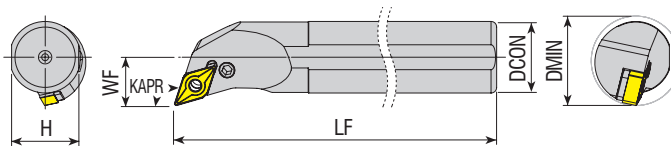

Código del Inserto Le Code de Commande Ordering Code	Stock Stock		Dimension (mm) Dimension (mm) Dimension (mm)					Inserto Plaquette Insert	Recambios / Pièces de Rechange / Spare Parts						
	R	L	DCON	H	LF	WF	DMIN		Palanca Lever Lever	Tornillo de Palanca Lever Vis Lever Screw	Cuñas Assise Shim	Cuñas Resorte Ressort à Cale Shim Spring	Abrazadera de Cuñas Motte de Fixation Wedge Clamp	Tornillo de Sujeción Vis de Fixation Wedge Screw	Llaves Allen Clés Allen Allen Wrench
	●	○													
S20R PDQNR/L 11	●	○	20	18.3	200	13	≥25	DNM. 1104..	APL-01	ALV-01-M6x14 ALV-02-M6x17	AADN-SD317	AAY-01			AAL-02-2.5
S25S PDQNR/L 11	●	●	25	23	250	17	≥32								
S32T PDQNR/L 15	●	●	32	30	300	22	≥40	DNM. 1506..	APL-03	ALV-03-M8x19	AADN-3-0001	AAY-02	-	-	AAL-03-3
S40U PDQNR/L 15	●	●	40	37.5	350	27	≥50								
S50V PDQNR/L 15	●	●	50	47	400	35	≥63	DNM. 1504..	APL-03	ALV-03-M8x19	AADN-2-0003	AAY-02	-	-	AAL-03-3
S32T PDQNR/L 1504	●	●	32	30	300	22	≥40								
S40U PDQNR/L 1504	●	●	40	37.5	350	27	≥50	DNM. 1506..	APL-03	ALV-03-M8x19	AADN-3-0001	AAY-02	-	-	AAL-03-3
S50V PDQNR/L 1504	●	●	50	47	400	35	≥63								
A20P PDQNR/L 11	●	●	20	18.3	170	13	≥25	DNM. 1104..	APL-01	ALV-01-M6x14 ALV-02-M6x17	AADN-SD317	AAY-01	-	-	AAL-02-2.5
A25R PDQNR/L 11	●	●	25	23	200	17	≥32								
A32S PDQNR/L 15	●	●	32	30	250	22	≥40	DNM. 1506..	APL-03	ALV-03-M8x19	AADN-3-0001	AAY-02	-	-	AAL-03-3
A40T PDQNR/L 15	●	●	40	37.5	300	27	≥50								
A50U PDQNR/L 15	●	●	50	47	350	35	≥63	DNM. 1504..	APL-03	ALV-03-M8x19	AADN-2-0003	AAY-02	-	-	AAL-03-3
A32S PDQNR/L 1504	●	●	32	30	250	22	≥40								
A40T PDQNR/L 1504	●	●	40	37.5	300	27	≥50								

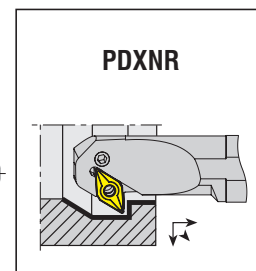
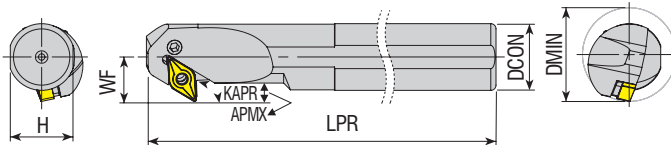

Código del Inserto Le Code de Commande Ordering Code	Stock Stock		Dimension (mm) Dimension (mm) Dimension (mm)					Inserto Plaquette Insert	Recambios / Pièces de Rechange / Spare Parts							
	R	L	DCON	H	LPR	WF	APMX		DMIN	Palanca Lever Lever	Tornillo de Palanca Lever Vis Lever Screw	Cuñas Assise Shim	Cuñas Resorte Ressort à Cale Shim Spring	Abrazadera de Cuñas Motte de Fixation Wedge Clamp	Tornillo de Sujeción Vis de Fixation Wedge Screw	Llaves Allen Clés Allen Allen Wrench
	●	○														
S32T PDXNR/L 15	●	●	32	30	300	22	12	≥45	DNM. 1506..	APL-03	ALV-08-M8x16 ALV-03-M8x19 ALV-08-M8x16 ALV-03-M8x19	AADN-3-0001	AAY-02	-	-	AAL-03-3
S40U PDXNR/L 15	●	●	40	37.5	350	27	14	≥50								
S50V PDXNR/L 15	●	●	50	47	400	35	19	≥63								
A32S PDXNR/L 15	●	●	32	30	250	22	12	≥40								
A40T PDXNR/L 15	●	●	40	37.5	300	27	14	≥50								
A50U PDXNR/L 15	●	●	50	47	350	35	19	≥63								

R: Derecha / Droite / Right L: Izquierda / Gauche / Left
 ● En Existencia / En stock / In Stock ○ Articulo sin Existencia / Indisponible en Stock / Non Stock Item
 Nota: Las dimensiones de "AMPX" se dan de acuerdo con R.08. Note: Les dimensions de "AMPX" sont donnés selon R.08. Note: Dimensions of "AMPX" are given according to R.08.

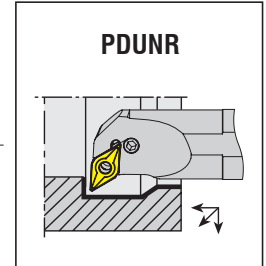
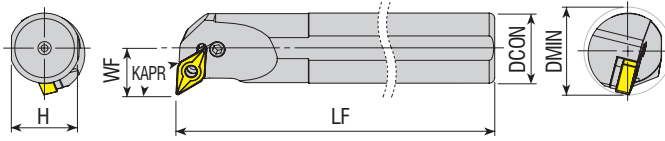

Código del Inserto Le Code de Commande Ordering Code	Stock		Dimension (mm) Dimension (mm) Dimension (mm)					Inserto Plaquette Insert	Recambios / Pièces de Rechange / Spare Parts						
	R	L	DCON	H	LF	WF	DMIN		Palanca Lever	Tornillo de Palanca Lever Vis	Cuñas Assise Shim	Cuñas Resorte Resort à Cale Shim Spring	Abrazadera de Cuñas Wedge Clamp	Tornillo de Sujeción Vis de Fixation Wedge Screw	Llaves Allen Cles Allen Allen Wrench
	●	●													
S20R PDUNR/L 11	●	●	20	18.3	200	13	≥25	DNM. 1104..	APL-01	ALV-01-M6x14	AADN-SD317	AAY-01	-	-	AAL-02-2.5
S25S PDUNR/L 11	●	●	25	23	250	17	≥32			ALV-02-M6x17					
S25S PDUNR/L 15	●	●	25	23	250	19	≥32			ALV-08-M8x16					
S32T PDUNR/L 15	●	●	32	30	300	22	≥40	DNM. 1506..	APL-03	ALV-03-M8x19	AADN-3-0001	AAY-02	-	-	AAL-03-3
S40U PDUNR/L 15	●	●	40	37.5	350	27	≥50								
S50V PDUNR/L 15	●	●	50	47	400	35	≥63								
A20P PDUNR/L 11	●	●	20	18.3	170	13	≥25	DNM. 1104..	APL-01	ALV-01-M6x14	AADN-SD317	AAY-01	-	-	AAL-02-2.5
A25R PDUNR/L 11	●	●	25	23	200	17	≥32			ALV-02-M6x17					
A32S PDUNR/L 11	●	●	32	30	250	22	≥40								
A32S PDUNR/L 15	●	●	32	30	250	22	≥40	DNM. 1506..	APL-03	ALV-03-M8x19	AADN-3-0001	AAY-02	-	-	AAL-03-3
A40T PDUNR/L 15	●	●	40	37.5	300	27	≥50								
A50U PDUNR/L 15	●	●	50	47	350	35	≥63								

R: Derecha / Droite / Right L: Izquierda / Gauche / Left

● En Existencia / En stock / In Stock ○ Artículo sin Existencia / Indisponible en Stock / Non Stock Item

Ejemplo de Pedido / Exemple de Commande / Ordering Example

1 Piezas / pcs. / pcs. S20R PDUNR 11



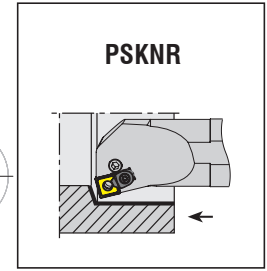
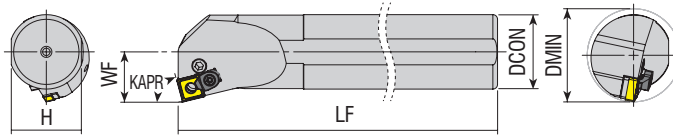

Código del Inserto
Le Code de Commande
Ordering Code

Recambios / Pièces de Rechange / Spare Parts

Código del Inserto Le Code de Commande Ordering Code	Stock Stock Stock		Dimension (mm) Dimension (mm) Dimension (mm)				Inserto Plaquette Insert	Palanca Lever Lever	Tornillo de Palanca Lever Vis Lever Screw	Cuñas Assise Shim	Cuñas Resorte Ressort a Cale Shim Spring	Abrazadera de Cuñas Mode de Fixation Wedge Clamp	Tornillo de Sujeción Vis de Fixation Wedge Screw	Llaves Allen Clés Allen Allen Wrench	
	R	L	DCON	H	LF	WF									DMIN
S25S PSKNR/L 12C	●	●	25	23	250	17	≥32	SNM. 1204..	APL-02	ALV-08-M8x16	AASN-3-0004	AAAY-02	ACK-05	4015-M4x11	AAL-03-3
S32T PSKNR/L 12C	●	●	32	30	300	22	≥40								
S40U PSKNR/L 12C	●	●	40	37.5	350	27	≥50								
S50V PSKNR/L 12C	●	●	50	47	400	35	≥63								
S32T PSKNR/L 15C	○	○	32	30	300	22	≥40	SNM. 1506..	APL-04	ALV-04-M8x22	AASN-3-0023	AAAY-03	ACK-09	AAV-05-M6x15	
S40U PSKNR/L 15C	○	●	40	37.5	350	27	≥50								
S50V PSKNR/L 15C	○	○	50	47	400	35	≥63								
A25R PSKNR/L 12C	●	●	25	23	200	17	≥32	SNM. 1204..	APL-02	ALV-08-M8x16	AASN-3-0004	AAAY-02	ACK-05	4015-M4x11	
A32S PSKNR/L 12C	●	●	32	30	250	22	≥40								
A40T PSKNR/L 12C	●	●	40	37.5	300	27	≥50								
A50U PSKNR/L 12C	○	●	50	47	350	35	≥63								
A32S PSKNR/L 15C	●	●	32	30	250	22	≥40	SNM. 1506..	APL-04	ALV-04-M8x22	AASN-3-0023	AAAY-03	ACK-09	AAV-05-M6x15	
A40T PSKNR/L 15C	●	●	40	37.5	300	27	≥50								
A50U PSKNR/L 15C	●	●	50	47	350	35	≥63								

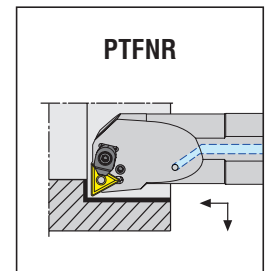
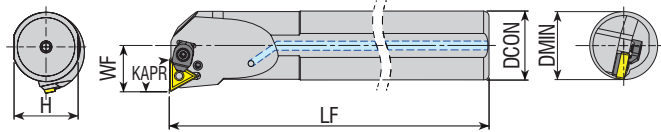

Código del Inserto
Le Code de Commande
Ordering Code

Recambios / Pièces de Rechange / Spare Parts

Código del Inserto Le Code de Commande Ordering Code	Stock Stock Stock		Dimension (mm) Dimension (mm) Dimension (mm)				Inserto Plaquette Insert	Palanca Lever Lever	Tornillo de Palanca Lever Vis Lever Screw	Cuñas Assise Shim	Cuñas Resorte Ressort a Cale Shim Spring	Abrazadera de Cuñas Mode de Fixation Wedge Clamp	Tornillo de Sujeción Vis de Fixation Wedge Screw	Llaves Allen Clés Allen Allen Wrench	
	R	L	DCON	H	LF	WF									DMIN
A25R PTFNR/L 16C	●	●	25	23	200	17	≥32	TNM. 1604..	APL-01	ALV-02-M6x17	AATN-3-0025	AAAY-01	ACK-05	4015-M4x11	AAL-03-3
A32S PTFNR/L 16C	●	●	32	30	250	22	≥40								

R: Derecha / Droite / Right L: Izquierda / Gauche / Left

● En Existencia / En stock / In Stock ○ Artículo sin Existencia / Indisponible in Stock / Non Stock Item

Ejemplo de Pedido / Exemple de Commande / Ordering Example

1 Piezas / pcs. / pcs. S25S PSKNR 12C

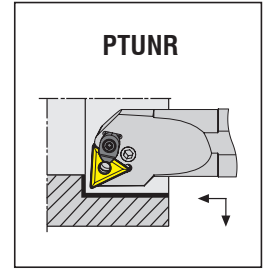
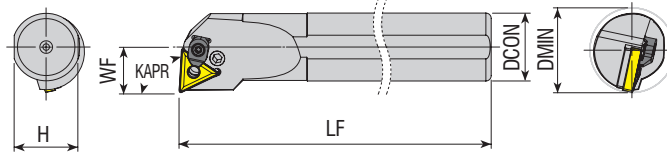

Código del Inserto Le Code de Commande Ordering Code	Stock		Dimension (mm) Dimension (mm)					Inserto Plaquette Insert	Recambios / Pièces de Rechange / Spare Parts												
	R	L	DCON	H	LF	WF	DMIN		Palanca Lever Lever	Tornillo de Palanca Lever Vis Lever Screw	Cuñas Assise Shim	Cuñas Resorte Ressort a Cale Shim Spring	Abrazadera de Cuñas Motte de Fixation Wedge Clamp	Tornillo de Sujeción Vis de Fixation Wedge Screw	Llaves Allen Clés Allen Allen Wrench						
S16P PTUNR/L 16	●	●	16	14.8	170	11	≥20	TNM. 1604..	APL-08	ALV-07-M6x13	-	AAY-07	-	-	AAL-02-2.5						
S20R PTUNR/L 16	●	●	20	18.3	200	13	≥25		APL-01	ALV-01-M6x14	AATN-3-0025	AAY-01	ACK-05	4015-M4x11							
S25S PTUNR/L 16C	●	●	25	23	250	17	≥32			ALV-02-M6x17											
S32T PTUNR/L 16C	●	●	32	30	300	22	≥40														
S40U PTUNR/L 16C	●	●	40	37.5	350	27	≥50														
S32T PTUNR/L 22C	●	●	32	30	300	22	≥40	TNM. 2204..	APL-02	ALV-03-M8x19	AATN-3-0015	AAY-02	ACK-05	4015-M4x11	AAL-03-3						
S40U PTUNR/L 22C	●	●	40	37.5	350	27	≥50														
S50V PTUNR/L 22C	●	●	50	47	400	35	≥63														
A16M PTUNR/L 16	●	●	16	14.8	150	11	≥20	TNM. 1604..	APL-08	ALV-07-M6x13	-	AAY-07	-	-							
A20P PTUNR/L 16	●	●	20	18.3	170	13	≥25														
A25R PTUNR/L 16C	●	●	25	23	200	17	≥32								APL-01	ALV-02-M6x17	AATN-3-0025	AAY-01	ACK-05	4015-M4x11	AAL-02-2.5
A32S PTUNR/L 16C	●	●	32	30	250	22	≥40														
A40T PTUNR/L 16C	●	●	40	37.5	300	27	≥50														
A32S PTUNR/L 22C	●	●	32	30	250	22	≥40	TNM. 2204..	APL-02	ALV-03-M8x19	AATN-3-0015	AAY-02	ACK-05	4015-M4x11	AAL-03-3						
A40T PTUNR/L 22C	●	●	40	37.5	300	27	≥50														

R: Derecha / Droite / Right L: Izquierda / Gauche / Left

● En Existencia / En stock / In Stock ○ Artículo sin Existencia / Indisponible en Stock / Non Stock Item

Ejemplo de Pedido / Exemple de Commande / Ordering Example

1 Piezas / pcs. / pcs. S16P PTUNR 16



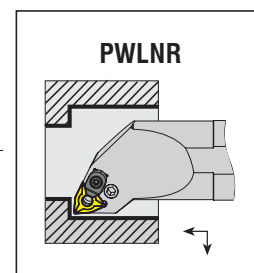
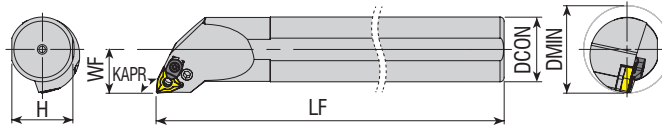

Código del Inserto Le Code de Commande Ordering Code	Stock		Dimension (mm) Dimension (mm)					Inserto Plaquette Insert	Recambios / Pièces de Rechange / Spare Parts						
	R	L	DCON	H	LF	WF	DMIN		Palanca Lever	Tornillo de Palanca Lever Vis	Cuñas Assise Shim	Cuñas Resorte Ressort a Cale Shim Spring	Abrazadera de Cuñas Mode de Fixation Wedge Clamp	Tornillo de Sujeción Vis de Fixation Wedge Screw	Llaves Allen Clés Allen Allen Wrench
	●	○													
S20R PWNLR/L 06	●	●	20	18.3	200	13	≥25	WNM. 0604..	APL-01	ALV-01-M6x14 ALV-02-M6x17	AAWN-SW317	AAY-01	-	-	AAL-02-2.5
S25S PWNLR/L 06	●	●	25	23	250	17	≥32								
S32T PWNLR/L 06	●	●	32	30	300	22	≥40								
S25S PWNLR/L 08C	●	●	25	23	250	17	≥32	WNM. 0804..	APL-02	ALV-03-M8x19	AAWN-3-0001	AAY-02	ACK-05	4015-M4x11	AAL-03-3
S32T PWNLR/L 08C	●	●	32	30	300	22	≥40								
S40U PWNLR/L 08C	●	●	40	37.5	350	27	≥50								
S50V PWNLR/L 08C	●	●	50	47	400	35	≥63	WNM. 0604..	APL-08	ALV-07-M6x13 ALV-01-M6x14	-	AAY-07	-	-	AAL-02-2.5
A16M PWNLR/L 06	●	●	16	14.8	150	11	≥20								
A20P PWNLR/L 06	●	●	20	18.3	170	13	≥25								
A25R PWNLR/L 06	●	●	25	23	200	17	≥32	WNM. 0804..	APL-02	ALV-03-M8x19	AAWN-3-0001	AAY-02	ACK-05	4015-M4x11	AAL-03-3
A32S PWNLR/L 06	●	●	32	30	250	22	≥40								
A40T PWNLR/L 06C	●	○	40	37.5	300	27	≥50								
A25R PWNLR/L 08C	●	●	25	23	200	17	≥32	WNM. 0804..	APL-02	ALV-03-M8x19	AAWN-3-0001	AAY-02	ACK-05	4015-M4x11	AAL-03-3
A32S PWNLR/L 08C	●	●	32	30	250	22	≥40								
A40T PWNLR/L 08C	●	●	40	37.5	300	27	≥50								
A50U PWNLR/L 08C	●	●	50	47	350	35	≥63								

R: Derecha / Droite / Right L: Izquierda / Gauche / Left

● En Existencia / En stock / In Stock ○ Artículo sin Existencia / Indisponible en Stock / Non Stock Item

Ejemplo de Pedido / Exemple de Commande / Ordering Example

1 Piezas / pcs. / pcs. S20R PWNLR 06



*konusulan
the spoken kalite...
quality...*

S-SYSTEM

BARRAS DE MANDRINAR SISTEMA S
BARRES DE D'ALEPAGE SYSTEME S
S-SYSTEM BORING BARS



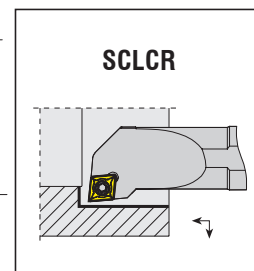
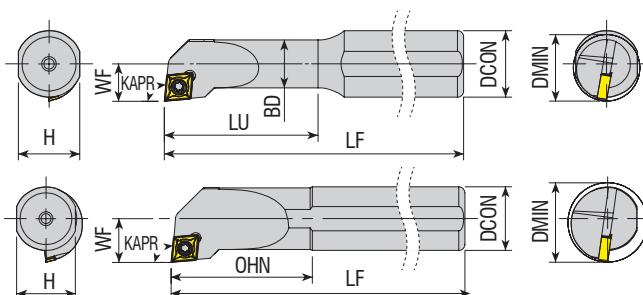

Código del Inserto Le Code de Commande Ordering Code	Stock		Dimension (mm) Dimension (mm) Dimension (mm)							Inserto Plaquette Insert	Recambios / Pièces de Rechange / Spare Parts			
	R	L	DCON	BD	H	LU=OHN	LF	WF	DMIN		Tornillo Vis Screw	Cuñas Assise Shim	Tornillo de Placa Vis a Assise Shim Screw	Llave Torx Clé Torx Torx Wrench
S0608H SCLCR/L 03	●	○	08	5	7.3	18	100	3	≥6	CC.T 030102	4006-M1.6x3.2			80-T06
S0608H SCLCR/L 06	●	●	08	6	7.3	25	100	4.5	≥8		4008-M2.5x4.5			
S08H SCLCR/L 06	●	●	08	8	7.3	20	100	06	≥11					
S10K SCLCR/L 06	●	●	10	10	09	25	125	07	≥13	CC.T 0602..	4008-M2.5x6	-	-	80-T08
S12K SCLCR/L 06	●	●	12	12	11	25	125	09	≥16					
S1216P SCLCR/L 06	●	●	16	11.5	14.8	37	170	09	≥16					
S16P SCLCR/L 06	●	●	16	16	14.8	35	170	11	≥20	CC.T 09T3..	4015-M3.5x8			80-T15
S12K SCLCR/L 09	●	●	12	12	11	30	125	09	≥16					
S1416P SCLCR/L 09	●	●	16	14	14.8	45	170	9.5	≥17					
S16P SCLCR/L 09	●	●	16	16	14.8	35	170	11	≥20					
S1620R SCLCR/L 09	●	●	20	16	18.3	50	200	11	≥20	CC.T 09T3..	4015-M3.5x9	-	-	80-T15
S20R SCLCR/L 09	●	●	20	20	18.3	40	200	13	≥25					
S25S SCLCR/L 09	●	●	25	25	23	50	250	17	≥32					
S32T SCLCR/L 09	●	●	32	32	30	60	300	22	≥40		4015-M3.5x12	AACN-2-0001	AAV-08-M3.5x8	
S25S SCLCR/L 12	●	●	25	25	23	50	250	17	≥32	CC.T 1204..	4020-M4.5x12	AACN-2-0003	AAV-10-M4.5x8	80-T20
S32T SCLCR/L 12	●	●	32	32	30	60	300	22	≥40					
S40U SCLCR/L 12	●	●	40	40	37.5	70	350	27	≥50		1020-M4.5x16		AAV-07-M4.5x13	
A08H SCLCR/L 06	●	●	08	8	7.3	20	100	06	≥11	CC.T 0602..	4008-M2.5x6	-	-	80-T08
A10H SCLCR/L 06	●	●	10	10	09	25	100	07	≥13					
A12H SCLCR/L 06	●	●	12	12	11	25	100	09	≥16					
A16M SCLCR/L 09	●	●	16	16	14.8	35	150	11	≥20	CC.T 09T3..	4015-M3.5x9	-	-	80-T15
A20P SCLCR/L 09	●	●	20	20	18.3	40	170	13	≥25					
A25R SCLCR/L 09	●	●	25	25	23	50	200	17	≥32					
A32S SCLCR/L 09	●	●	32	32	30	60	250	22	≥40		4015-M3.5x12	AACN-2-0001	AAV-08-M3.5x8	
A25R SCLCR/L 12	●	●	25	25	23	50	200	17	≥32	CC.T 1204..	4020-M4.5x12	AACN-2-0003	AAV-10-M4.5x8	80-T20

R: Derecha / Droite / Right L: Izquierda / Gauche / Left

● En Existencia / En stock / In Stock ○ Artículo sin Existencia / Indisponible en Stock / Non Stock Item

Ejemplo de Pedido / Exemple de Commande / Ordering Example

1 Piezas / pcs. / pcs. S0608H SCLCR 03

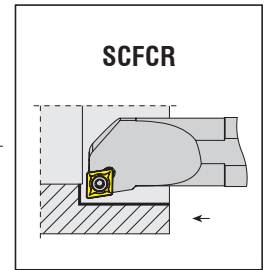
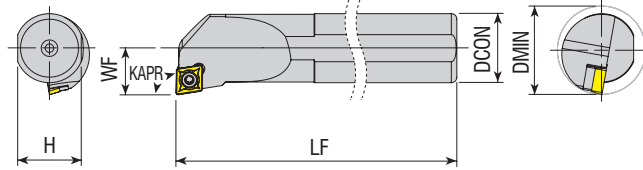

Código del Inserto
Le Code de Commande
Ordering Code

Stock Stock Stock	Dimension (mm) Dimension (mm) Dimension (mm)						Inserto Plaquette Insert	Recambios / Pièces de Rechange / Spare Parts				
	R	L	DCON	H	LF	WF		DMIN	Tornillo Vis Screw	Cuñas Assise Shim	Tornillo de Placa Vis a Assise Shim Screw	Llave Torx Clé Torx Torx Wrench
	●	●	08	7.3	100	06	≥11	CC.T 0602..	4008-M2.5x6	-	-	80-T08
S08H SCFCR/L 06	●	●	10	09	125	07	≥13		4015-M3.5x8			
S10K SCFCR/L 06	●	●	12	11	125	09	≥16		4015-M3.5x9	-	-	
S12K SCFCR/L 06	●	●	12	11	125	09	≥16	CC.T 09T3..	4015-M3.5x12	AACN-2-0001	AAV-08-M3.5x8	80-T15
S12K SCFCR/L 09	●	●	16	14.8	170	11	≥20		4015-M3.5x9	-	-	
S16P SCFCR/L 09	●	●	20	18.3	200	13	≥25		4015-M3.5x12	AACN-2-0001	AAV-08-M3.5x8	
S20R SCFCR/L 09	●	●	25	23	250	17	≥32	CC.T 1204..	4020-M4.5x12	AACN-2-0003	AAV-10-M4.5x8	80-T20
S25S SCFCR/L 09	●	●	25	23	250	17	≥32		1020-M4.5x16		AAV-07-M4.5x13	
S25S SCFCR/L 12	○	○	32	30	300	22	≥40		4008-M2.5x6	-	-	
S32T SCFCR/L 12	○	○	40	37.5	350	27	≥50	CC.T 0602..	4008-M2.5x6	-	-	80-T08
S40U SCFCR/L 12	○	○	08	7.3	100	06	≥11					
A08H SCFCR/L 06	●	○										

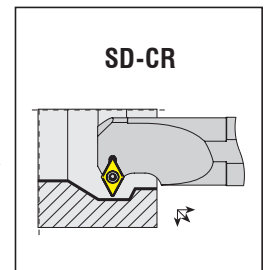
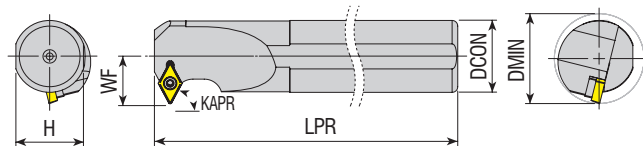

Código del Inserto
Le Code de Commande
Ordering Code

Stock Stock Stock	Dimension (mm) Dimension (mm) Dimension (mm)						Inserto Plaquette Insert	Recambios / Pièces de Rechange / Spare Parts				
	R	L	DCON	H	LPR	WF		DMIN	Tornillo Vis Screw	Cuñas Assise Shim	Tornillo de Placa Vis a Assise Shim Screw	Llave Torx Clé Torx Torx Wrench
	●	●	10	9	125	07	≥14	DC.T 0702..	4008-M2.5x6	-	-	80-T08
S10K SD-CR/L 07	●	●	12	11	125	09	≥16		4015-M3.5x11	-	-	
S12K SD-CR/L 07	●	●	16	14.8	170	11	≥20		4015-M3.5x14	AADN-2-0001	AAV-06-M3.5x11	
S16P SD-CR/L 07	●	●	20	18.3	200	13	≥25	DC.T 11T3..	4015-M3.5x11	-	-	80-T15
S20R SD-CR/L 07	●	○	16	14.8	170	14	≥22		4015-M3.5x14	AADN-2-0001	AAV-06-M3.5x11	
S16P SD-CR/L 11	●	●	20	18.3	200	15	≥25					
S20R SD-CR/L 11	●	●	25	23	250	18	≥32	DC.T 11T3..	4015-M3.5x14	AADN-2-0001	AAV-06-M3.5x11	80-T15
S25S SD-CR/L 11	●	●	32	30	300	22	≥40					
S32T SD-CR/L 11	●	●	40	37.5	350	27	≥50					
S40U SD-CR/L 11	●	●										

R: Derecha / Droite / Right L: Izquierda / Gauche / Left

● En Existencia / En stock / In Stock ○ Artículo sin Existencia / Indisponible en Stock / Non Stock Item

Ejemplo de Pedido / Exemple de Commande / Ordering Example

1 Piezas / pcs. / pcs. S08H SCFCR 06

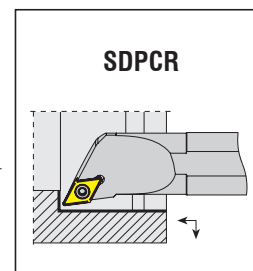
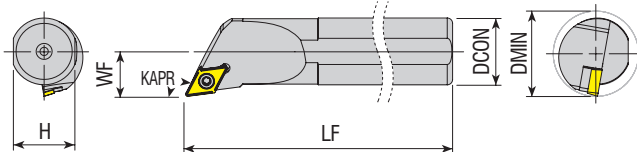

Código del Inserto Le Code de Commande Ordering Code	Stock		Dimension (mm) Dimension (mm) Dimension (mm)				Inserto Plaquette Insert	Recambios / Pièces de Rechange / Spare Parts				
	R	L	DCON	H	LF	WF		DMIN	Tornillo Vis Screw	Cuñas Assise Shim	Tornillo de Placa Vis a Assise Shim Screw	Llave Torx Clé Torx Torx Wrench
S10K SDPCR/L 07	●	●	10	09	125	07	≥13	DC.T 0702..	4008-M2.5x6	-	-	80-T08
S12K SDPCR/L 07	●	●	12	11	125	09	≥16					
S16P SDPCR/L 11	●	●	16	14.8	170	11	≥20	DC.T 11T3..	4015-M3.5x9	-	-	80-T15
S20R SDPCR/L 11	●	●	20	18.3	200	13	≥25		4015-M3.5x11			
S25S SDPCR/L 11	●	●	25	23	250	17	≥32		4015-M3.5x12			

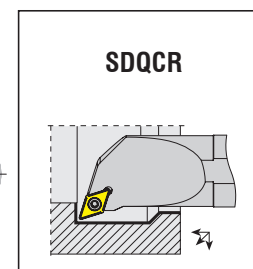
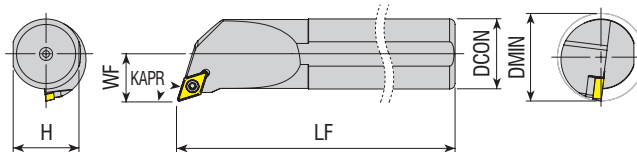

Código del Inserto Le Code de Commande Ordering Code	Stock		Dimension (mm) Dimension (mm) Dimension (mm)				Inserto Plaquette Insert	Recambios / Pièces de Rechange / Spare Parts					
	R	L	DCON	H	LF	WF		DMIN	Tornillo Vis Screw	Cuñas Assise Shim	Tornillo de Placa Vis a Assise Shim Screw	Llave Torx Clé Torx Torx Wrench	
S10K SDQCR/L 07	●	●	10	09	125	07	≥13	DC.T 0702..	4008-M2.5x6	-	-	80-T08	
S12K SDQCR/L 07	●	●	12	11	125	09	≥16						
S16P SDQCR/L 07	●	●	16	14.8	170	11	≥20	DC.T 11T3..	4015-M3.5x9	-	-	80-T15	
S20R SDQCR/L 07	●	●	20	18.3	200	13	≥25		4015-M3.5x11				
S16P SDQCR/L 11	●	●	16	14.8	170	11	≥20		4015-M3.5x12				AADN-2-0001
S20R SDQCR/L 11	●	●	20	18.3	200	13	≥25	4015-M3.5x14	AADN-2-0001	AAV-06-M3.5x11	80-T15		
S25S SDQCR/L 11	●	●	25	23	250	17	≥32						
S32T SDQCR/L 11	●	●	32	30	300	22	≥40	DC.T 0702..	4008-M2.5x6	-	-	80-T08	
S40U SDQCR/L 11	●	●	40	37.5	350	27	≥50						
A10H SDQCR/L 07	●	●	10	09	100	07	≥13	DC.T 11T3..	4015-M3.5x9	-	-	80-T15	
A12H SDQCR/L 07	●	●	12	11	100	09	≥16						4015-M3.5x11
A16M SDQCR/L 07	●	●	16	14.8	150	11	≥20						4015-M3.5x12
A20P SDQCR/L 07	●	●	20	18.3	170	13	≥25	4015-M3.5x14	AADN-2-0001	AAV-06-M3.5x11	80-T15		
A16M SDQCR/L 11	●	●	16	14.8	150	11	≥20						
A20P SDQCR/L 11	●	●	20	18.3	170	13	≥25	DC.T 11T3..	4015-M3.5x12	-	-	80-T15	
A25R SDQCR/L 11	●	●	25	23	200	17	≥32						4015-M3.5x11
A32S SDQCR/L 11	●	●	32	30	250	22	≥40						4015-M3.5x14

R: Derecha / Droite / Right L: Izquierda / Gauche / Left

● En Existencia / En stock / In Stock ○ Artículo sin Existencia / Indisponible en Stock / Non Stock Item

Ejemplo de Pedido / Exemple de Commande / Ordering Example

1 Piezas / pcs. / pcs. S10K SDPCR 07

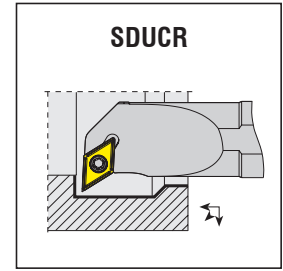
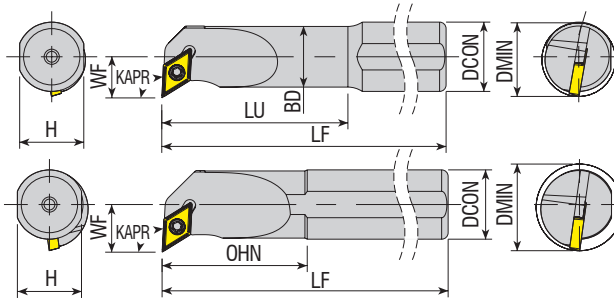

Código del Inserto Le Code de Commande Ordering Code	Stock		Dimension (mm) Dimension (mm)								Inserto Plaquette Insert	Recambios / Pièces de Rechange / Spare Parts			
	R	L	DCON	BD	H	LU=OHN	LF	WF	DMIN	Tornillo Vis Screw		Cuñas Assise Shim	Tornillo de Placa Vis a Assise Shim Screw	Llave Torx Cle Torx Torx Wrench	
	●	○													
S0810K SDUCR/L 07	●	●	10	8	09	30	125	08	≥13	DC.T 0702..	4008-M2.5x6	-	-	80-T08	
S10K SDUCR/L 07	●	●	10	10	09	25	125	08	≥13						
S12K SDUCR/L 07	●	●	12	12	11	25	125	09	≥16						
S1216P SDUCR/L 07	●	●	16	11.5	14.8	37	170	09	≥16						
S1416P SDUCR/L 07	●	●	16	14	14.8	45	170	9.5	≥17						
S16P SDUCR/L 07	●	●	16	16	14.8	35	170	11	≥20						
S20R SDUCR/L 07	●	●	20	20	18.3	40	200	13	≥25	DC.T 11T3..	4015-M3.5x9	-	-	80-T15	
S1416P SDUCR/L 11	●	●	16	14	14.8	45	170	11	≥18						
S16P SDUCR/L 11	●	●	16	16	14.8	35	170	11	≥20						
S1620R SDUCR/L 11	●	●	20	16	18.3	50	200	11	≥20						
S20R SDUCR/L 11	●	●	20	20	18.3	40	200	13	≥25						
S25S SDUCR/L 11	●	●	25	25	23	50	250	17	≥32						
S32T SDUCR/L 11	●	●	32	32	30	60	300	22	≥40	DC.T 0702..	4008-M2.5x6	-	-	80-T08	
S40U SDUCR/L 11	●	●	40	40	37.5	70	350	27	≥50						
S50V SDUCR/L 11	●	●	50	50	47	80	400	35	≥63						
A0810H SDUCR/L 07	●	●	10	8	09	30	100	08	≥13						
A10H SDUCR/L 07	●	●	10	10	09	25	100	08	≥13						
A12H SDUCR/L 07	●	●	12	12	11	25	100	09	≥16						
A16M SDUCR/L 07	●	●	16	16	14.8	35	150	11	≥20	DC.T 11T3..	4015-M3.5x9	-	-	80-T15	
A20P SDUCR/L 07	●	●	20	20	18.3	40	170	13	≥25						
A16M SDUCR/L 11	●	●	16	16	14.8	35	150	11	≥20						
A20P SDUCR/L 11	●	●	20	20	18.3	40	170	13	≥25						
A25R SDUCR/L 11	●	●	25	25	23	50	200	17	≥32						
A32S SDUCR/L 11	●	●	32	32	30	60	250	22	≥40						

R: Derecha / Droite / Right L: Izquierda / Gauche / Left

● En Existencia / En stock / In Stock ○ Artículo sin Existencia / Indisponible en Stock / Non Stock Item

Ejemplo de Pedido / Exemple de Commande / Ordering Example

1 Piezas / pcs. / pcs. S0810K SDUCR 07

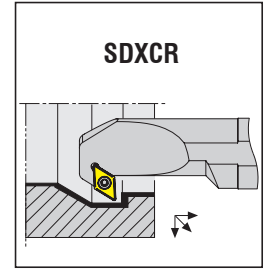
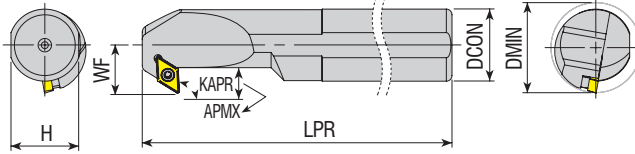

Recambios / Pièces de Rechange / Spare Parts

Código del Inserto
Le Code de Commande
Ordering Code

Stock Stock Stock	Dimension (mm) Dimension (mm) Dimension (mm)							Inserto Plaquette Insert	Recambios / Pièces de Rechange / Spare Parts				
	R	L	DCON	H	LPR	WF	APMX		DMIN	Tornillo Vis Screw	Cuñas Assise Shim	Tornillo de Placa Vis a Assise Shim Screw	Llave Torx Clé Torx Torx Wrench
	●	●	12	11	125	09	4.5	≥16	DC.T 0702..	4008-M2.5x6	-	-	80-T08
	●	●	16	14.8	170	11	6.5	≥20		4015-M3.5x11	-	-	80-T08
	●	●	20	18.3	200	13	6.5	≥25					
	●	●	16	14.8	170	11	6.5	≥20	DC.T 11T3..				
	●	●	20	18.3	200	14	7.5	≥25					
	●	●	25	23	250	17	9	≥32				AAV-08-M3.5x8	80-T15
	●	●	32	30	300	22	12.5	≥40		4015-M3.5x14	AADN-2-0001	AAV-06-M3.5x11	
	●	●	40	37.5	350	27	14.5	≥50					
	●	●	12	11	100	09	4.5	≥16	DC.T 0702..	4008-M2.5x6	-	-	80-T08
	●	●	16	14.8	150	11	6.5	≥20					
	●	●	20	18.3	170	13	6.5	≥25					
	●	●	16	14.8	150	11	7.5	≥20	DC.T 11T3..	4015-M3.5x11	-	-	
	●	●	20	18.3	170	14	7.5	≥25					
	●	●	25	23	200	17	9	≥32				AAV-08-M3.5x8	80-T15
	●	●	32	30	250	22	12.5	≥40		4015-M3.5x14	AADN-2-0001	AAV-06-M3.5x11	

R: Derecha / Droite / Right L: Izquierda / Gauche / Left

● En Existencia / En stock / In Stock ○ Artículo sin Existencia / Indisponible en Stock / Non Stock Item

Nota: Las dimensiones de "APMX" se dan de acuerdo con R.04.

Note: Les dimensions de "APMX" sont donnés selon R.04.

Note: Dimensions of "APMX" are given according to R.0,4

Ejemplo de Pedido / Exemple de Commande / Ordering Example

1 Piezas / pcs. / pcs. S12K SDXCR 07

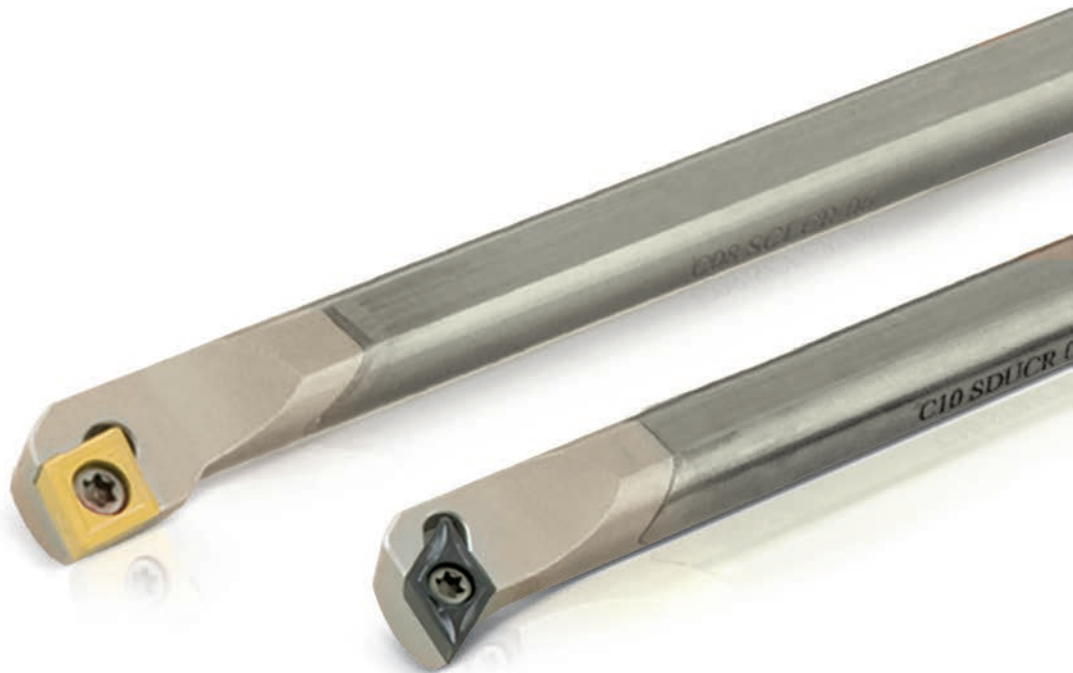

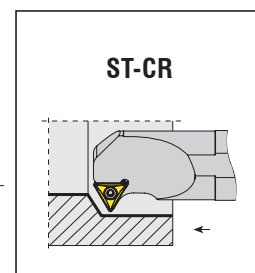
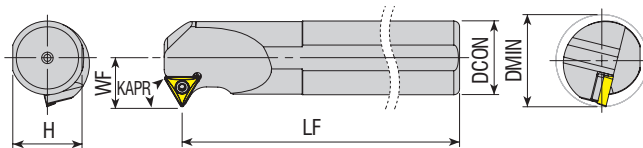

Código del Inserto Le Code de Commande Ordering Code	Stock		Dimension (mm) Dimension (mm)				Inserto Plaque Insert	Recambios / Pièces de Rechange / Spare Parts				
	R	L	DCON	H	LF	WF		DMIN	Tornillo Vis Screw	Cuñas Assise Shim	Tornillo de Placa Vis a Assise Shim Screw	Llave Torx Cle Torx Torx Wrench
S12K ST-CR/L 11	●	●	12	11	125	09	≥17			-	-	
S16P ST-CR/L 11	●	○	16	14.8	170	11	≥20					
S20R ST-CR/L 11	●	○	20	18.3	200	13	≥25		 	-	-	
S16P ST-CR/L 16	●	●	16	14.8	170	11	≥20					
S20R ST-CR/L 16	●	●	20	18.3	200	13	≥25			AATN-2-0001	AAV-08-M3.5x8 AAV-06-M3.5x11	
S25S ST-CR/L 16	●	●	25	23	250	17	≥32					
S32T ST-CR/L 16	●	●	32	30	300	22	≥40			AATN-2-0001	AAV-08-M3.5x8 AAV-06-M3.5x11	
S40U ST-CR/L 16	●	●	40	37.5	350	27	≥50					

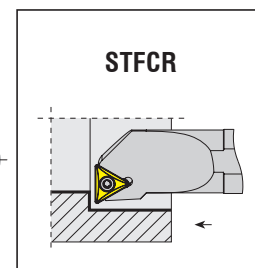
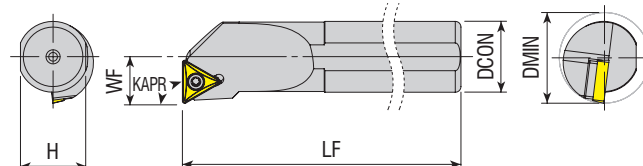

Código del Inserto Le Code de Commande Ordering Code	Stock		Dimension (mm) Dimension (mm)				Inserto Plaque Insert	Recambios / Pièces de Rechange / Spare Parts				
	R	L	DCON	H	LF	WF		DMIN	Tornillo Vis Screw	Cuñas Assise Shim	Tornillo de Placa Vis a Assise Shim Screw	Llave Torx Cle Torx Torx Wrench
S0610F STFCR/L06	●	●	10	09	80	4.5	≥08			-	-	
S08H STFCR/L 06	●	●	08	7.3	100	06	≥11					
S10K STFCR/L 09	●	●	10	09	125	07	≥13			-	-	
S12K STFCR/L 09	●	●	12	11	125	09	≥17					
S12K STFCR/L 11	●	●	12	11	125	09	≥17			-	-	
S16P STFCR/L 11	●	●	16	14.8	170	11	≥20					
S20R STFCR/L 11	●	●	20	18.3	200	13	≥25		 	-	-	
S16P STFCR/L 16	●	●	16	14.8	170	11	≥20					
S20R STFCR/L 16	●	●	20	18.3	200	13	≥25			AATN-2-0001	AAV-08-M3.5x8 AAV-06-M3.5x11	
S25S STFCR/L 16	●	●	25	23	250	17	≥32					
S32T STFCR/L 16	●	●	32	30	300	22	≥40			AATN-2-0001	AAV-08-M3.5x8 AAV-06-M3.5x11	
S40U STFCR/L 16	●	○	40	37.5	350	27	≥50					
A10H STFCR/L 11	●	●	10	09	100	07	≥13			-	-	
A12H STFCR/L 11	●	●	12	11	100	09	≥17					
A16M STFCR/L 11	●	●	16	14.8	150	11	≥20					

R: Derecha / Droite / Right L: Izquierda / Gauche / Left

● En Existencia / En stock / In Stock ○ Artículo sin Existencia / Indisponible en Stock / Non Stock Item

Ejemplo de Pedido / Exemple de Commande / Ordering Example

1 Piezas / pcs. / pcs. S12K ST-CR 11

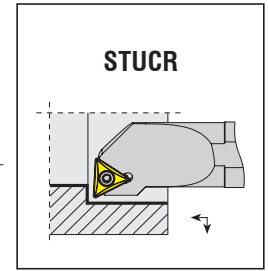
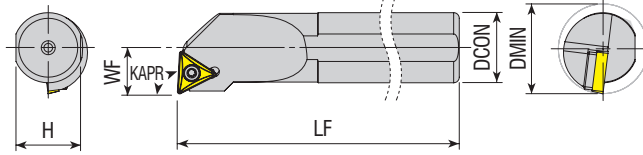

Código del Inserto
 Le Code de Commande
 Ordering Code

Stock
 Stock
 Stock

Dimension (mm)
 Dimension (mm)
 Dimension (mm)

Inserto
 Plaquette
 Insert

Tornillo
 Vis
 Screw

Cuñas
 Assise
 Shim

Tornillo de Placa
 Vis a Assise
 Shim Screw

Llave Torx
 Clé Torx
 Torx Wrench

Recambios / Pièces de Rechange / Spare Parts

Código del Inserto Le Code de Commande Ordering Code	Stock		Dimension (mm)				Inserto Plaquette Insert	Tornillo Vis Screw	Cuñas Assise Shim	Tornillo de Placa Vis a Assise Shim Screw	Llave Torx Clé Torx Torx Wrench	
	R	L	DCON	H	LF	WF						DMIN
S10K STUCR/L 09	●	●	10	09	125	07	≥13	TC.T 0902..	3007-M2.2x5		80-T07	
S12K STUCR/L 09	●	●	12	11	125	09	≥16					
S12K STUCR/L 11	●	●	12	11	125	09	≥17	TC.T 1102..	4008-M2.5x6		80-T08	
S16P STUCR/L 11	●	●	16	14.8	170	11	≥20					
S20R STUCR/L 11	●	●	20	18.3	200	13	≥25	TC.T 16T3..	4015-M3.5x9 4015-M3.5x11		80-T15	
S16P STUCR/L 16	●	●	16	14.8	170	11	≥20					
S20R STUCR/L 16	●	●	20	18.3	200	13	≥25	4015-M3.5x14	AATN-2-0001	AAV-08-M3.5x8 AAV-06-M3.5x11	80-T15	
S25S STUCR/L 16	●	●	25	23	250	17	≥32					
S32T STUCR/L 16	●	●	32	30	300	22	≥40	TC.T 0902..	3007-M2.2x5		80-T07	
S40U STUCR/L 16	●	●	40	37.5	350	27	≥50					
A10H STUCR/L 09	●	●	10	09	100	07	≥13	TC.T 1102..	4008-M2.5x6		80-T08	
A12H STUCR/L 09	●	●	12	11	100	09	≥16					
A12H STUCR/L 11	●	●	12	11	100	09	≥16	TC.T 16T3..	4015-M3.5x9 4015-M3.5x11		80-T15	
A16M STUCR/L 11	●	●	16	14.8	150	11	≥20					
A20P STUCR/L 11	●	●	20	18.3	170	13	≥25	4015-M3.5x14	AATN-2-0001	AAV-08-M3.5x8 AAV-06-M3.5x11	80-T15	
A16M STUCR/L 16	●	●	16	14.8	150	11	≥20					
A20P STUCR/L 16	●	●	20	18.3	170	13	≥25	TC.T 0902..	3007-M2.2x5		80-T07	
A25R STUCR/L 16	●	●	25	23	200	17	≥32					
A32S STUCR/L 16	●	●	32	30	250	22	≥40	TC.T 16T3..	4015-M3.5x14	AATN-2-0001	AAV-08-M3.5x8 AAV-06-M3.5x11	80-T15
A25R STUCR/L 16	●	●	25	23	200	17	≥32					

R: Derecha / Droite / Right L: Izquierda / Gauche / Left

● En Existencia / En stock / In Stock ○ Artículo sin Existencia / Indisponible en Stock / Non Stock Item

Ejemplo de Pedido / Exemple de Commande / Ordering Example

1 Piezas / pcs. / pcs. S10K STUCR 09



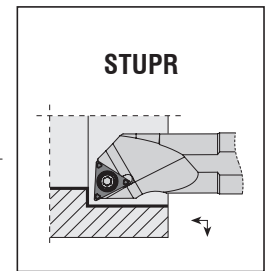
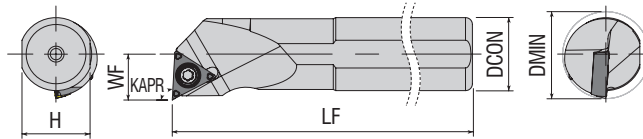

Código del Inserto
Le Code de Commande
Ordering Code

Stock Stock Stock	Dimension (mm) Dimension (mm) Dimension (mm)						Inserto Plaquette Insert	Recambios / Pièces de Rechange / Spare Parts				
	R	L	DCON	H	LF	WF		DMIN	Tornillo Vis Screw	Cuñas Assise Shim	Tornillo de Placa Vis a Assise Shim Screw	Llave Torx Cle Torx Torx Wrench
S08H STUPR/L 0802	● ○		08	7.3	100	05	≥10	TP. 1103..	3006-M2x4	-	-	80-T06
S10K STUPR/L 1103	● ○		10	09	125	06	≥12		4010-M3x6			
S12K STUPR/L 1103	● ●		12	11	125	09	≥16		4010-M3x8			
S12M STUPR/L 1103	● ●		12	11	150	08	≥16					
S16P STUPR/L 1103	● ●		16	14.8	170	10	≥20					
S16R STUPR/L 1103	● ●		16	14.8	200	10	≥20					
A20R STUPR/L 1103	● ○		20	18.3	200	13	≥25					

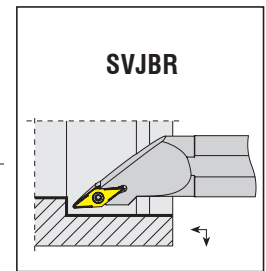
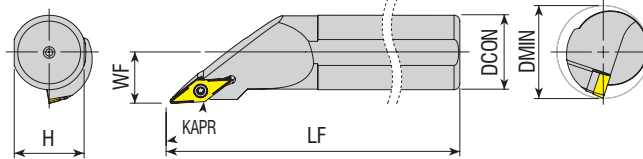

Código del Inserto
Le Code de Commande
Ordering Code

Stock Stock Stock	Dimension (mm) Dimension (mm) Dimension (mm)						Inserto Plaquette Insert	Recambios / Pièces de Rechange / Spare Parts				
	R	L	DCON	H	LF	WF		DMIN	Tornillo Vis Screw	Cuñas Assise Shim	Tornillo de Placa Vis a Assise Shim Screw	Llave Torx Cle Torx Torx Wrench
S25S SVJBR/L 16	● ●		25	23	250	17	≥32	VB.T 1604..	4015-M3.5x12	AAVN-2-0002	AAV-08-M3.5x8	80-T15
S32T SVJBR/L 16	● ●		32	30	300	22	≥40		4015-M3.5x14		AAV-06-M3.5x11	
S40U SVJBR/L 16	● ●		40	37.5	350	27	≥50					

R: Derecha / Droite / Right L: Izquierda / Gauche / Left

● En Existencia / En stock / In Stock ○ Artículo sin Existencia / Indisponible en Stock / Non Stock Item

Ejemplo de Pedido / Exemple de Commande / Ordering Example

1 Piezas / pcs. / pcs. S08H STUPR 0802

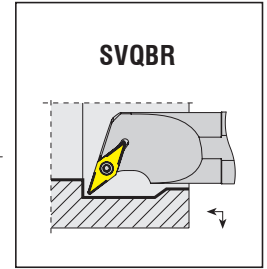
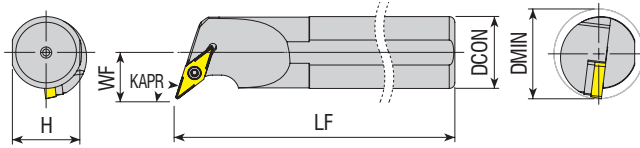

Código del Inserto Le Code de Commande Ordering Code	Stock		Dimension (mm) Dimension (mm) Dimension (mm)				Inserto Plaquette Insert	Recambios / Pièces de Rechange / Spare Parts				
	R	L	DCON	H	LF	WF		DMIN	Tornillo Vis Screw	Cuñas Assise Shim	Tornillo de Placa Vis a Assise Shim Screw	Llave Torx Clé Torx Torx Wrench
S16P SVQBR/L 11	●	●	16	14.8	170	11	≥20	VB.T 1103..	4008-M2.5x6	-	-	80-T08
S20R SVQBR/L 11	●	●	20	18.3	200	13	≥25					
S25S SVQBR/L 16	●	●	25	23	250	17	≥32	VB.T 1604..	4015-M3.5x14	AAVN-2-0002	AAV-08-M3.5x8	80-T15
S32T SVQBR/L 16	●	●	32	30	300	22	≥40				AAV-06-M3.5x11	
S40U SVQBR/L 16	●	●	40	37.5	350	27	≥50	VB.T 1103..	4008-M2.5x6	-	-	80-T08
A20Q SVQBR/L 11	●	●	20	18.5	180	13	≥25					
A20Q SVQBR/L 16	●	●	20	18.5	180	20	≥30	VB.T 1604..	4015-M3.5x11	AAVN-2-0002	AAV-06-M3.5x11	80-T15
A25S SVQBR/L 16	●	●	25	23	250	17	≥32		4015-M3.5x14			
A32S SVQBR/L 16	●	●	32	30	250	22	≥40					

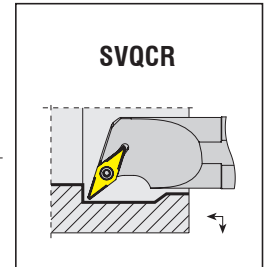
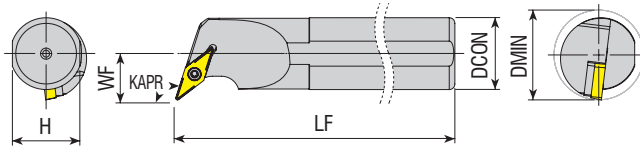

Código del Inserto Le Code de Commande Ordering Code	Stock		Dimension (mm) Dimension (mm) Dimension (mm)				Inserto Plaquette Insert	Recambios / Pièces de Rechange / Spare Parts				
	R	L	DCON	H	LF	WF		DMIN	Tornillo Vis Screw	Cuñas Assise Shim	Tornillo de Placa Vis a Assise Shim Screw	Llave Torx Clé Torx Torx Wrench
S16P SVQCR/L 11	●	●	16	14.8	170	11	≥20	VC.T 1103..	4008-M2.5x6	-	-	80-T08
S20R SVQCR/L 11	●	●	20	18.3	200	13	≥25					
S25S SVQCR/L 16	●	●	25	23	250	17	≥32	VC.T 1604..	4015-M3.5x14	AAVN-2-0002	AAV-08-M3.5x8	80-T15
S32T SVQCR/L 16	●	●	32	30	300	22	≥40				AAV-06-M3.5x11	
S40U SVQCR/L 16	●	●	40	37.5	350	27	≥50	VC.T 1103..	4008-M2.5x6	-	-	80-T08
A16M SVQCR/L 11	●	●	16	14.8	150	11	≥20					
A20P SVQCR/L 11	●	●	20	18.3	170	13	≥25	VC.T 1604..	4015-M3.5x14	AAVN-2-0002	AAV-08-M3.5x8	80-T15
A25R SVQCR/L 16	●	●	25	23	200	17	≥32				AAV-06-M3.5x11	
A32S SVQCR/L 16	●	●	32	30	250	22	≥40					
A40T SVQCR/L 16	●	●	40	37.5	300	27	≥50					

R: Derecha / Droite / Right L: Izquierda / Gauche / Left

● En Existencia / En stock / In Stock ○ Artículo sin Existencia / Indisponible en Stock / Non Stock Item

Ejemplo de Pedido / Exemple de Commande / Ordering Example

1 Piezas / pcs. / pcs. S16P SVQBR 11

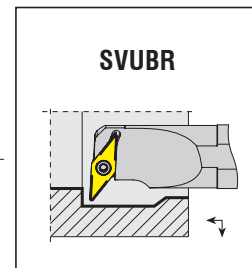
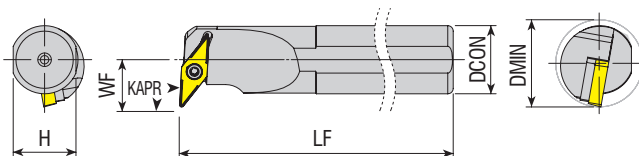

Código del Inserto
Le Code de Commande
Ordering Code

Stock
Stock

Dimension (mm)
Dimension (mm)

Inserto
Plaquette
Insert

Tornillo
Vis
Screw

Cuñas
Assise
Shim

Tornillo de Placa
Vis a Assise
Shim Screw

Llave Torx
Clé Torx
Torx Wrench

Recambios / Pièces de Rechange / Spare Parts

R	L	DCON	H	LF	WF	DMIN
---	---	------	---	----	----	------



S16P SVUBR/L 11	●	●	16	14.8	170	12.5	≥20	VB.T 1103..	4008-M2.5x6	-	-	80-T08
S20R SVUBR/L 11	●	●	20	18.3	200	13	≥25					
S25S SVUBR/L 16	●	●	25	23	250	19	≥32	VB.T 1604..	4015-M3.5x14	AAVN-2-0002	AAV-06-M3.5x11	80-T15
S32T SVUBR/L 16	●	●	32	30	300	22	≥40					
S40U SVUBR/L 16	●	●	40	37.5	350	27	≥50					
A20Q SVUBR/L 16	●	○	20	18.3	180	20	≥30					
A32S SVUBR/L 16	●	●	32	30	250	22	≥40	4015-M3.5x11	-	-		
								4015-M3.5x14	AAVN-2-0002	AAV-06-M3.5x11		

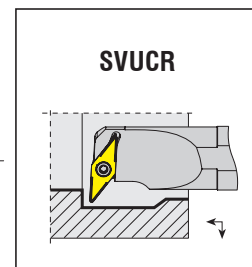
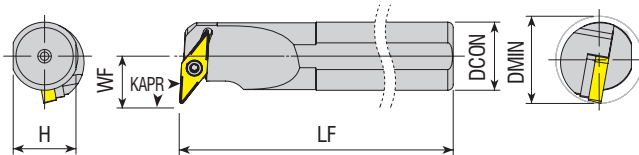

Código del Inserto
Le Code de Commande
Ordering Code

Stock
Stock

Dimension (mm)
Dimension (mm)

Inserto
Plaquette
Insert

Tornillo
Vis
Screw

Cuñas
Assise
Shim

Tornillo de Placa
Vis a Assise
Shim Screw

Llave Torx
Clé Torx
Torx Wrench

Recambios / Pièces de Rechange / Spare Parts

R	L	DCON	H	LF	WF	DMIN
---	---	------	---	----	----	------



S16P SVUCR/L 11	●	●	16	14.8	170	12.5	≥20	VC.T 1103..	4008-M2.5x6	-	-	80-T08
S20R SVUCR/L 11	●	●	20	18.3	200	13	≥25					
S25S SVUCR/L 16	●	●	25	23	250	19	≥32	VC.T 1604..	4015-M3.5x14	AAVN-2-0002	AAV-06-M3.5x11	80-T15
S32T SVUCR/L 16	●	●	32	30	300	22	≥40					
S40U SVUCR/L 16	●	●	40	37.5	350	27	≥50					
A12K SVUCR/L 07	●	●	12	11	125	9	≥16					
A20P SVUCR/L 11	●	○	20	18.3	170	13	≥25	VC.T 1103..	4008-M2.5x6	-	-	80-T08
A20Q SVUCR/L 11	●	●	20	18.3	180	13	≥25	VC.T 1103..	4008-M2.5x6	-	-	80-T08
A25R SVUCR/L 16	●	●	25	23	200	19	≥32	VC.T 1604..	4015-M3.5x14	AAVN-2-0002	AAV-06-M3.5x11	80-T15

R: Derecha / Droite / Right L: Izquierda / Gauche / Left

● En Existencia / En stock / In Stock ○ Artículo sin Existencia / Indisponible en Stock / Non Stock Item

Ejemplo de Pedido / Exemple de Commande / Ordering Example

1 Piezas / pcs. / pcs. S16P SVUBR 11

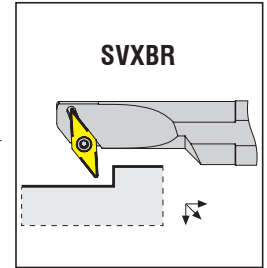
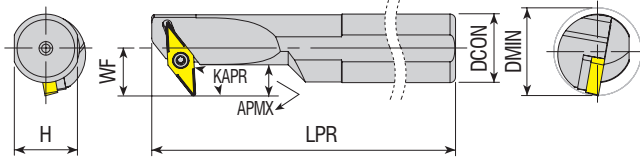

Código del Inserto Le Code de Commande Ordering Code	Stock		Dimension (mm) Dimension (mm) Dimension (mm)					Inserto Plaquette Insert	Recambios / Pièces de Rechange / Spare Parts				
	R	L	DCON	H	LPR	WF	APMX		DMIN	Tornillo Vis Screw	Cuñas Assise Shim	Tornillo de Placa Vis a Assise Shim Screw	Llave Torx Cle Torx Torx Wrench
S16P SVXBR/L 1102	●	○	16	14.8	170	12.5	7.2	≥20	VBM. 1102..	4008-M2.5x6	-	-	80-T08
S20R SVXBR/L 1102	●	●	20	18.3	200	13	5.7	≥25					
S16P SVXBR/L 11	●	●	16	14.8	170	12.5	7.2	≥20	VB.T 1103..				
S20R SVXBR/L 11	●	●	20	18.3	200	13	5.7	≥25					
S25S SVXBR/L 16	●	●	25	23	250	19	10.2	≥32	VB.T 1604..	4015-M3.5x14	AAVN-2-0002	AAV-06-M3.5x11	80-T15
S32T SVXBR/L 16	●	●	32	30	300	22	11.7	≥40					
S40U SVXBR/L 16	●	●	40	37.5	350	27	14.3	≥50					

Nota: Las dimensiones de "APMX" se dan de acuerdo con R.04.
 Note: Les dimensions de "APMX" sont donnés selon R04.
 Note: Dimensions of "APMX" are given according to R.0.4

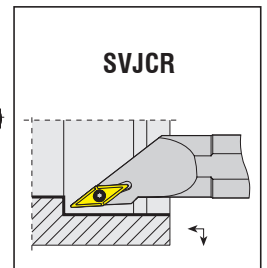
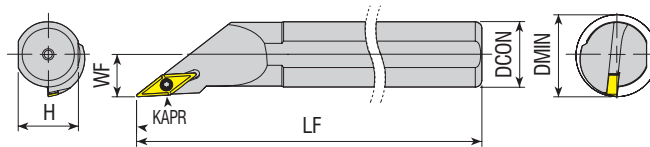

Código del Inserto Le Code de Commande Ordering Code	Stock		Dimension (mm) Dimension (mm) Dimension (mm)					Inserto Plaquette Insert	Recambios / Pièces de Rechange / Spare Parts			
	R	L	DCON	H	LF	WF	DMIN		Tornillo Vis Screw	Cuñas Assise Shim	Tornillo de Placa Vis a Assise Shim Screw	Llave Torx Cle Torx Torx Wrench
S12K SVJCR/L 11	●	●	12	11	125	7	≥13	VC.T 1103..	4008-M2.5x6	-	-	80-T08
S16P SVJCR/L 11	●	●	16	14.8	170	11	≥20					
S20R SVJCR/L 11	●	●	20	18.3	200	13	≥25					
A12H SVJCR/L 11	●	●	12	11	100	07	≥13					
A16M SVJCR/L 11	●	●	16	14.8	150	11	≥20					
A20P SVJCR/L 11	●	●	20	18.3	170	13	≥25					

R: Derecha / Droite / Right L: Izquierda / Gauche / Left
 ● En Existencia / En stock / In Stock ○ Artículo sin Existencia / Indisponible en Stock / Non Stock Item

Ejemplo de Pedido / Exemple de Commande / Ordering Example
 1 Piezas / pcs. / pcs. S16P SVXBR 1102

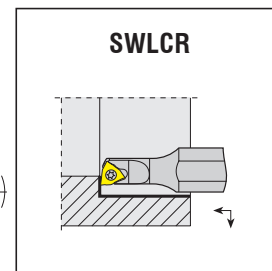
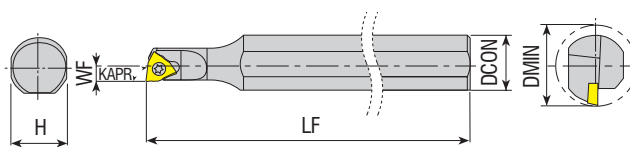

Código del Inserto Le Code de Commande Ordering Code	Stock Stock	Dimension (mm) Dimension (mm)						Inserto Plaquette Insert	Recambios / Pièces de Rechange / Spare Parts				
		DCON	H	LF	WF	DMIN	Tornillo Vis Screw		Cuñas Assise Shim	Tornillo de Placa Vis a Assise Shim Screw	Llave Torx Clé Torx Torx Wrench		
S0608H SWLCR 03	●	08	7.3	100	04	≥08	WC.. 0302..						
S0810K SWLCR 03	●	10	09	125	06	≥10							4008-M2.5x4.5

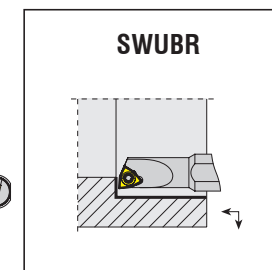
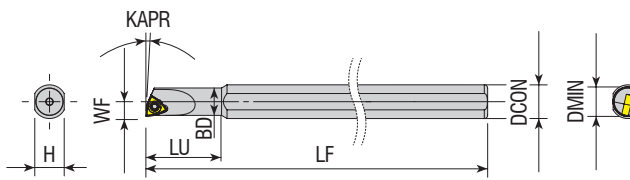

Código del Inserto Le Code de Commande Ordering Code	Stock Stock	Dimension (mm) Dimension (mm)							Inserto Plaquette Insert	Recambios / Pièces de Rechange / Spare Parts								
		DCON	BD	H	LU	LF	DMIN	WF		Tornillo Vis Screw	Cuñas Assise Shim	Tornillo de Placa Vis a Assise Shim Screw	Llave Torx Clé Torx Torx Wrench					
S0610H SWUBR 06	●	10	5	7.3	18	100	≥6	3	WBGT 060102-L									
S08H SWUBR 06-5.5	●	08	5	7.3	18	100	≥5.7	2.75							3006-M2x3.3	-	-	80-T06
S08H SWUBR 06-7	●	08	6.5	7.3	18	100	≥7	3.5							3006-M2x4	-	-	80-T06

R: Derecha / Droite / Right L: Izquierda / Gauche / Left
 ● En Existencia / En stock / In Stock ○ Artículo sin Existencia / Indisponible en Stock / Non Stock Item
 Compatible con el Inserto KYCR-ISCR. / Compatible avec KYCR-ISCR Plaquettes. / Compatible with KYCR-ISCR Insert.

Ejemplo de Pedido / Exemple de Commande / Ordering Example
 1 Piezas / pcs. / pcs. S0608H SWLCR 03

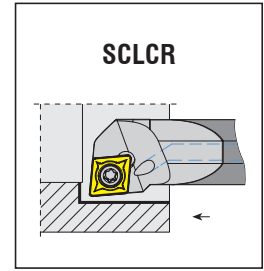
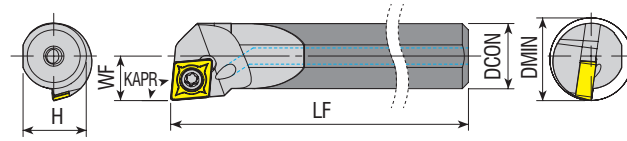

Código del Inserto Le Code de Commande Ordering Code	Stock		Dimension (mm) Dimension (mm)					Inserto Plaquette Insert	Recambios / Pièces de Rechange / Spare Parts			
	R	L	DCON	H	LF	WF	DMIN		Tornillo Vis Screw	Cuñas Assise Shim	Tornillo de Placa Vis a Assise Shim Screw	Llave Torx Clé Torx Torx Wrench
C06J SCLCR/L 06	●	○	6	5.7	110	4.5	≥8	CC.T 0602..				
E08K SCLCR/L 06	●	●	8	7.5	125	6	≥11					
E10M SCLCR/L 06	●	●	10	9.5	150	7	≥13					
E12Q SCLCR/L 06	●	●	12	11	180	9	≥16					
E16R SCLCR/L 09	●	●	16	15	200	11	≥20	CC.T 09T3..				
E20S SCLCR/L 09	●	●	20	19	250	13	≥24					

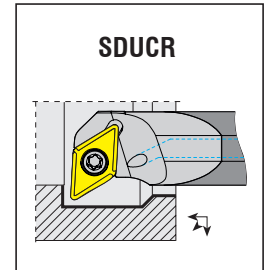
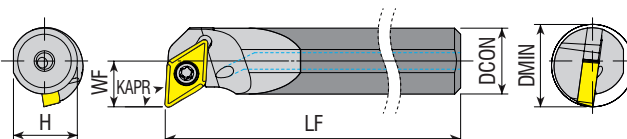

Código del Inserto Le Code de Commande Ordering Code	Stock		Dimension (mm) Dimension (mm)					Inserto Plaquette Insert	Recambios / Pièces de Rechange / Spare Parts			
	R	L	DCON	H	LF	WF	DMIN		Tornillo Vis Screw	Cuñas Assise Shim	Tornillo de Placa Vis a Assise Shim Screw	Llave Torx Clé Torx Torx Wrench
E10M SDUCR/L 07	●	●	10	9.5	150	8	≥13	DC.T 0702..				
E12Q SDUCR/L 07	●	●	12	11	180	9	≥16					
E16R SDUCR/L 11	●	●	16	15	200	11	≥20	DC.T 11T3..				
E20S SDUCR/L 11	●	●	20	18.3	250	12	≥23					

R: Derecha / Droite / Right L: Izquierda / Gauche / Left

● En Existencia / En stock / In Stock ○ Artículo sin Existencia / Indisponible en Stock / Non Stock Item

Ejemplo de Pedido / Exemple de Commande / Ordering Example

1 Piezas / pcs. / pcs. C06J SCLCR 06



KAPR=90°

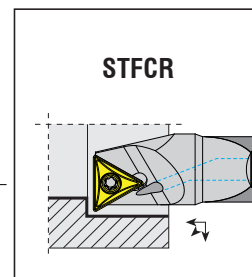
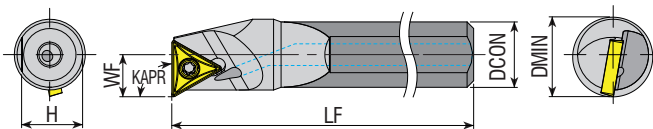

Código del Inserto
Le Code de Commande
Ordering Code

Stock
Stock
Stock

Dimension (mm)
Dimension (mm)
Dimension (mm)

Inserto
Plaque
Insert

Tornillo
Vis
Screw

Cuñas
Assise
Shim

Tornillo de Placa
Vis a Assise
Shim Screw

Llave Torx
Clé Torx
Torx Wrench

R L

DCON

H

LF

WF

DMIN

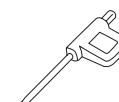

E10M STFCR/L 09

● ○

10

9.5

150

6

12

TC.T 0902..

3007-M2.2x5

E12Q STFCR/L 09

● ○

12

11

180

8

15

TC.T 1102..

4008-M2.5x6

E12Q STFCR/L 11

● ○

12

11

180

8

15

TC.T 1102..

4008-M2.5x6

80-T07

80-T08

Recambios / Pièces de Rechange / Spare Parts



KAPR=93°

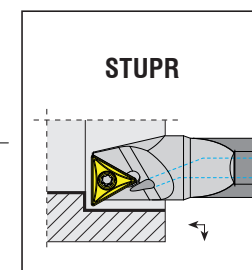
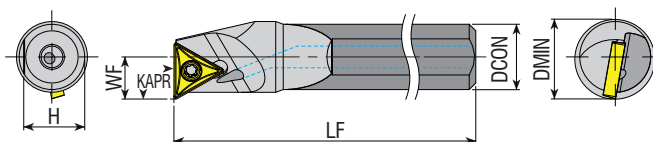

Código del Inserto
Le Code de Commande
Ordering Code

Stock
Stock
Stock

Dimension (mm)
Dimension (mm)
Dimension (mm)

Inserto
Plaque
Insert

Tornillo
Vis
Screw

Cuñas
Assise
Shim

Tornillo de Placa
Vis a Assise
Shim Screw

Llave Torx
Clé Torx
Torx Wrench

R L

DCON

H

LF

WF

DMIN



E12Q STUPR/L 1103

● ○

12

11

180

8

15

TP. 1103..

4010-M3x6

E16R STUPR/L 1103

● ○

16

15

200

11

20

TP. 1103..

4010-M3x8

80-T10

R: Derecha / Droite / Right L: Izquierda / Gauche / Left

● En Existencia / En stock / In Stock ○ Artículo sin Existencia / Indisponible en Stock / Non Stock Item

Ejemplo de Pedido / Exemple de Commande / Ordering Example

1 Piezas / pcs. / pcs. E10M STFCR 09

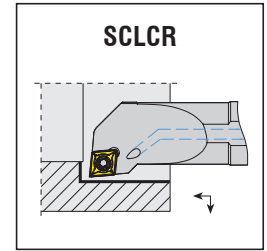
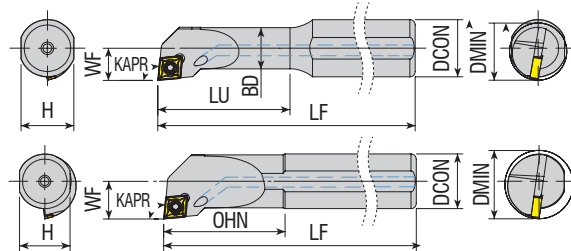

Código del Inserto
 Le Code de Commande
 Ordering Code

Stock Stock	Dimension (mm) Dimension (mm) Dimension (mm)									Inserto Plaquette Insert	Recambios / Pièces de Rechange / Spare Parts			
	R	L	DCON	BD	H	LU=OHN	LF	WF	DMIN		Tornillo Vis Screw	Cuñas Assise Shim	Tornillo de Placa Vis a Assise Shim Screw	Llave Torx Clé Torx Torx Wrench
●●	●●	8	8	7.3	20	100	6	≥11	CC.T 0602..	4008-M2.5x6	-	-	80-T08	
●●	●●	10	10	9	25	100	7	≥13						
●●	●●	12	12	11	25	100	9	≥16						
●●	●●	16	16	14.8	35	150	11	≥20						CC.T 09T3..

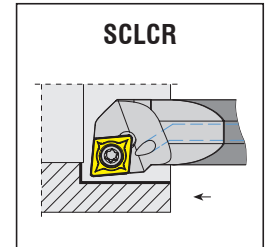
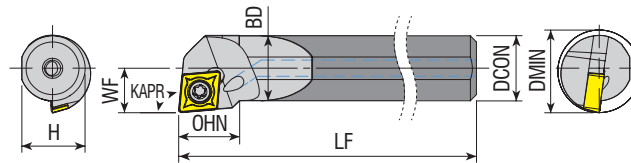

Código del Inserto
 Le Code de Commande
 Ordering Code

Stock Stock	Dimension (mm) Dimension (mm) Dimension (mm)									Inserto Plaquette Insert	Recambios / Pièces de Rechange / Spare Parts			
	R	L	DCON	BD	H	OHN	LF	WF	DMIN		Tornillo Vis Screw	Cuñas Assise Shim	Tornillo de Placa Vis a Assise Shim Screw	Llave Torx Clé Torx Torx Wrench
●○	○	8	8	7.5	10	125	6	≥11	CC.T 0602..	4008-M2.5x6	-	-	80-T08	
●○	○	10	10	9.5	10	150	7	≥13						
●○	○	12	12	11	12	180	9	≥16						
●○	○	16	16	15	15	200	11	≥20						CC.T 09T3..

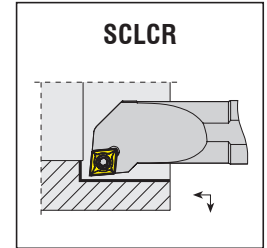
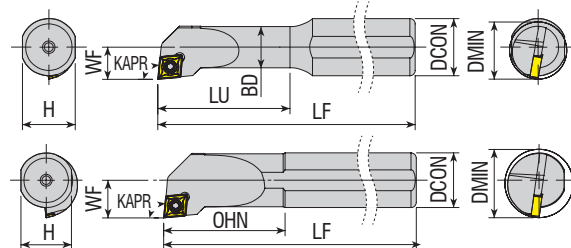

Código del Inserto
 Le Code de Commande
 Ordering Code

Stock Stock	Dimension (mm) Dimension (mm) Dimension (mm)									Inserto Plaquette Insert	Recambios / Pièces de Rechange / Spare Parts			
	R	L	DCON	BD	H	LU=OHN	LF	WF	DMIN		Tornillo Vis Screw	Cuñas Assise Shim	Tornillo de Placa Vis a Assise Shim Screw	Llave Torx Clé Torx Torx Wrench
●●	●●	8	8	7.3	20	100	6	≥11	CC.T 0602..	4008-M2.5x6	-	-	80-T08	
●●	●●	10	10	9	25	125	7	≥13						
●●	●●	12	12	11	25	125	9	≥16						
●●	●●	16	16	14.8	35	170	11	≥20						CC.T 09T3..

R: Derecha / Droite / Right L: Izquierda / Gauche / Left

● En Existencia / En stock / In Stock ○ Artículo sin Existencia / Indisponible en Stock / Non Stock Item

Ejemplo de Pedido / Exemple de Commande / Ordering Example

1 Piezas / pcs. / pcs. SET-A/SCLCR

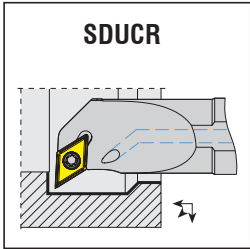
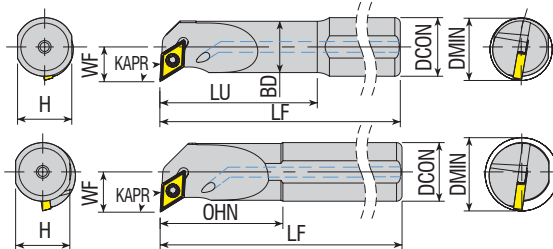

Código del Inserto Le Code de Commande Ordering Code	Stock		Dimension (mm) Dimension (mm) Dimension (mm)							Inserto Plaquette Insert	Recambios / Pièces de Rechange / Spare Parts			
	R	L	DCON	BD	H	LU=OHN	LF	WF	DMIN		Tornillo Vis Screw	Cuñas Assise Shim	Tornillo de Placa Vis a Assise Shim Screw	Llave Torx Clé Torx Torx Wrench
A10H SDUCR/L 07	●	●	10	10	09	25	100	08	≥13	DC.T 0702..	4008-M2.5x6	-	-	80-T08
A12H SDUCR/L 07	●	●	12	12	11	25	100	09	≥16					
A16M SDUCR/L 11	●	●	16	16	14.8	35	150	11	≥20					

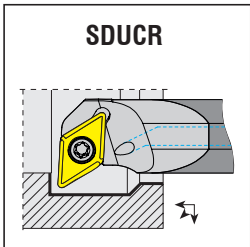
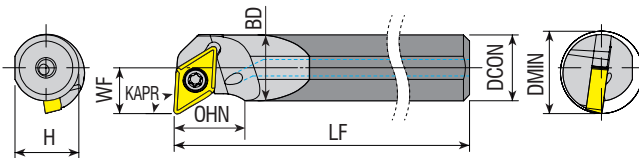

Código del Inserto Le Code de Commande Ordering Code	Stock		Dimension (mm) Dimension (mm) Dimension (mm)							Inserto Plaquette Insert	Recambios / Pièces de Rechange / Spare Parts			
	R	L	DCON	BD	H	OHN	LF	WF	DMIN		Tornillo Vis Screw	Cuñas Assise Shim	Tornillo de Placa Vis a Assise Shim Screw	Llave Torx Clé Torx Torx Wrench
E10M SDUCR/L 07	●	○	10	10	9.5	09	150	8	≥13	DC.T 0702..	4008-M2.5x6	-	-	80-T08
E12Q SDUCR/L 07	●	○	12	12	11	10	180	9	≥16					
E16R SDUCR/L 11	●	○	16	16	15	12	200	11	≥20					

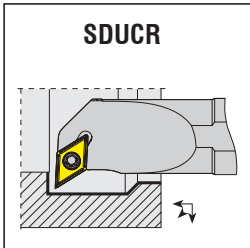
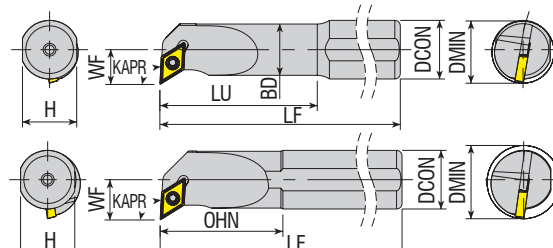
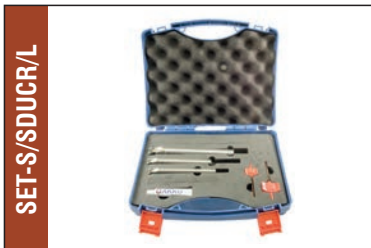

Código del Inserto Le Code de Commande Ordering Code	Stock		Dimension (mm) Dimension (mm) Dimension (mm)							Inserto Plaquette Insert	Recambios / Pièces de Rechange / Spare Parts			
	R	L	DCON	BD	H	LU=OHN	LF	WF	DMIN		Tornillo Vis Screw	Cuñas Assise Shim	Tornillo de Placa Vis a Assise Shim Screw	Llave Torx Clé Torx Torx Wrench
S10K SDUCR/L 07	●	●	10	10	9	25	125	8	≥13	DC.T 0702..	4008-M2.5x6	-	-	80-T08
S12K SDUCR/L 07	●	●	12	12	11	25	125	9	≥16					
S16P SDUCR/L 11	●	●	16	16	14.8	35	170	11	≥20					

R: Derecha / Droite / Right L: Izquierda / Gauche / Left

● En Existencia / En stock / In Stock ○ Artículo sin Existencia / Indisponible en Stock / Non Stock Item

Ejemplo de Pedido / Exemple de Commande / Ordering Example

1 Piezas / pcs. / pcs. SET-A/SDUCR



konusulan
the spoken kalite...
quality...

ANTIVIBRATION

HERRAMIENTAS ANTIVIBRACION
OUTILS ANTI VIBRATOIRES
ANTIVIBRATION TOOLS





AKKO **A** **TT** **B** **D16** **204** **10D** **H** **E**

2 Tipo de Herramienta <i>Type D'outil</i> <i>Tool Type</i>	3 Cuerpo <i>Corps</i> <i>Body</i>	4 Diámetro de Conexión <i>Diamètre de Connexion</i> <i>Connection Diameter</i>	5 Longitud Total <i>Longeur Totale</i> <i>Overall Length</i>	6 Maximo Permitido <i>Débord Maximale</i> <i>Overhang maximum</i>	7 Con Agujero de Refrigerante <i>Avec Trou D'arrosage</i> <i>With Coolant Hole</i>
Herramientas Antivibración <i>Outil Anti Vibratoire</i> <i>Anti Vibration Tool</i>					
8 Tipo de Cabezas de Perforación <i>Type de Barre D'alésage</i> <i>Type of Boring Bar</i>					
Carburo Reforzado <i>Carbure Renforcé</i> <i>Carbide Reinforced</i>					

AKKO **A** **TT** **C** **A** **16** **SDUCR11**

2 Tipo de Herramienta <i>Type D'outil</i> <i>Tool Type</i>	3 Código de Cartucho <i>Code de Cartouche</i> <i>Cartridge Code</i>	4 Con Agujero de Refrigerante <i>Avec Trou D'arrosage</i> <i>With Coolant Hole</i>	5 Diámetro de Conexión <i>Diamètre de Connexion</i> <i>Connection Diameter</i>
Cartucho de Herramientas Antivibración <i>Cartouche a Outils Antivibratoires</i> <i>Anti Vibration Tool Cartridge</i>	Cartucho <i>Cartouche</i> <i>Cartridge</i>		Ø16 - Ø20 - Ø25 Ø32 - Ø40
2 Tipo de Cartucho <i>Type de Cartouche</i> <i>Cartridge Type</i>			
SDUCR/L, SCLCR/L, SVUCR/L, TCLNR/L, TDUNR/L			

AKKO **A** **TT** **C** **16-25**

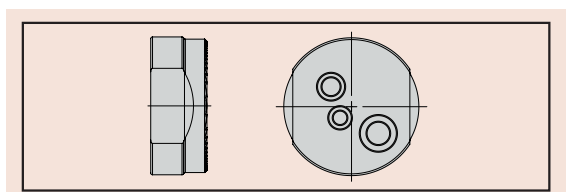

2 Tipo de Herramienta <i>Type D'outil</i> <i>Tool Type</i>	3 Cartucho <i>Cartouche</i> <i>Cartridge</i>	4 Rango de Diámetro Utilizable Para el Cuerpo <i>Intervalle de Diamètre Utile Pour le Corps</i> <i>Usable Diameter Range for Body</i>
Cartucho de Herramientas Antivibración <i>Cartouche a Outils Antivibratoires</i> <i>Anti Vibration Tool Cartridge</i>	Código de Cartucho de Centrado <i>Code de la Cartouche Centrage</i> <i>Centering Cartridge Code</i>	ATTB-D16/D20/D25 ATTB-D32/D40/D50/D60

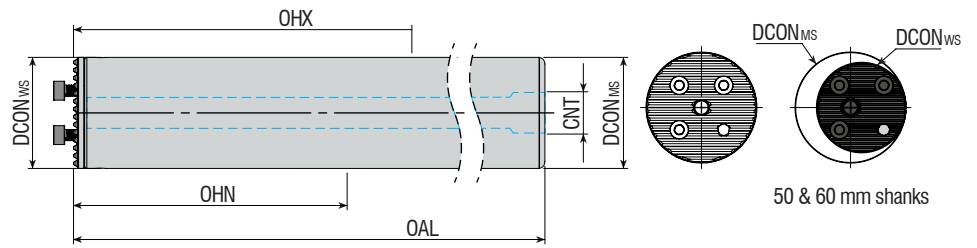

Código del Inserto
 Le Code de Commande
 Ordering Code

Stock
 Stock
 Stock

Dimension (mm)
 Dimension (mm)
 Dimension (mm)

Recambios / Pièces de Rechange / Spare Parts

Tornillo de Fijación
 Vis de Fixation
 Mounting Screw

Llaves Allen
 Clés Allen
 Allen Wrench

Código del Inserto Le Code de Commande Ordering Code	Stock Stock Stock	DCONMS	DCONWS	OAL	OHN	OHX	CNT	Dimension (mm) Dimension (mm) Dimension (mm)		Tornillo de Fijación Vis de Fixation Mounting Screw	Llaves Allen Clés Allen Allen Wrench
								DMIN	DCON		
ATTB-D16-156-7D-H	○	16	16	156	55	92	G1/8	16	20	2525-M3X10	AAL-02-2.5
ATTB-D16-204-10D-H-E	○	16	16	204	96	140	G1/8	16	20		
ATTB-D20-200-7D-H	○	20	20	200	70	120	G1/4	20	25	M3.5X10	AAL-02-2.5
ATTB-D20-260-10D-H-E	○	20	20	260	120	180	G1/4	20	25		
ATTB-D25-255-7D-H	○	25	25	255	88	158	G1/4	25	32	2503-M4X12	AAL-03-3
ATTB-D25-330-10D-H	○	25	25	330	155	230	G1/4	25	32		
ATTB-D32-320-7D-H	○	32	32	320	100	192	G3/8	32	40	2504-M5X16	AAL-05-4
ATTB-D32-416-10D-H	○	32	32	416	192	288	G3/8	32	40		
ATTB-D40-408-7D-H	○	40	40	408	128	248	G1/2	40	50	2505-M6X16	AAL-07-5
ATTB-D40-528-10D-H	○	40	40	528	248	368	G1/2	40	50		
ATTB-D50-519-7D-H	●	50	40	519	168	318	G1/2	40	63	2505-M6X16	AAL-07-5
ATTB-D50-669-10D-H	○	50	40	669	318	468	G1/2	40	63		
ATTB-D60-628-7D-H	○	60	40	628	208	388	G3/4	40	80	2505-M6X16	AAL-07-5
ATTB-D60-808-10D-H	○	60	40	808	388	568	G3/4	40	80		

R: Derecha / Droite / Right L: Izquierda / Gauche / Left

● En Existencia / En stock / In Stock ○ Artículo sin Existencia / Indisponible en Stock / Non Stock Item

Ejemplo de Pedido / Exemple de Commande / Ordering Example

1 Piezas / pcs. / pcs. ATTB-D16-156-7D-H





KAPR=93°

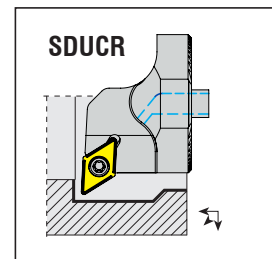
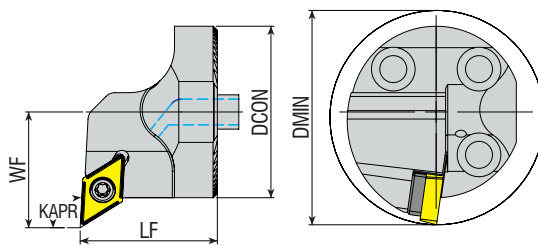

Código del Inserto
Le Code de Commande
Ordering Code

Stock Stock Stock	Dimension (mm) Dimension (mm) Dimension (mm)					Inserto Plaquette Insert	Recambios / Pièces de Rechange / Spare Parts			
	R	L	DCON	LF	WF		Tornillo Vis Screw	Cuñas Assise Shim	Tornillo de Placa Vis a Assise Shim Screw	Llave Torx Clé Torx Torx Wrench
						DC.T 0702..	4008-M2.5x6	-	-	80-T08
					4015-M3.5x11					
						DC.T 11T3..	4015-M3.5x12		AAV-08-M3.5x8	80-T15
					4015-M3.5x14		AADN-2-0001	AAV-06-M3.5x11		



KAPR=95°

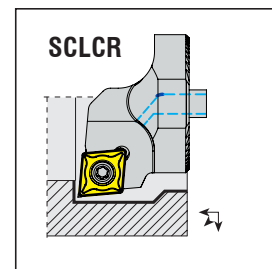
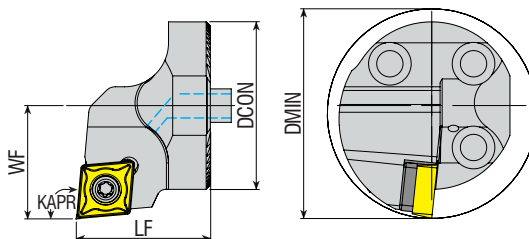

Código del Inserto
Le Code de Commande
Ordering Code

Stock Stock Stock	Dimension (mm) Dimension (mm) Dimension (mm)					Inserto Plaquette Insert	Recambios / Pièces de Rechange / Spare Parts			
	R	L	DCON	LF	WF		Tornillo Vis Screw	Cuñas Assise Shim	Tornillo de Placa Vis a Assise Shim Screw	Llave Torx Clé Torx Torx Wrench
						CC.T 0602..	4008-M2.5x6	-	-	80-T08
					4015-M3.5x9					
						CC.T 09T3..	4015-M3.5x12	AACN-2-0001	AAV-08-M3.5x8	80-T15
					4015-M3.5x12					
						CC.T 1204..	1020-M4.5x16	AACN-2-0003	AAV-07-M4.5x13	80-T20

R: Derecha / Droite / Right L: Izquierda / Gauche / Left

● En Existencia / En stock / In Stock ○ Artículo sin Existencia / Indisponible en Stock / Non Stock Item

Ejemplo de Pedido / Exemple de Commande / Ordering Example

1 Piezas / pcs. / pcs. ATTC-A16-SDUCR 07



KAPR=93°

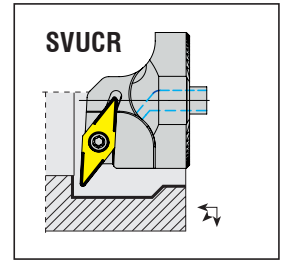
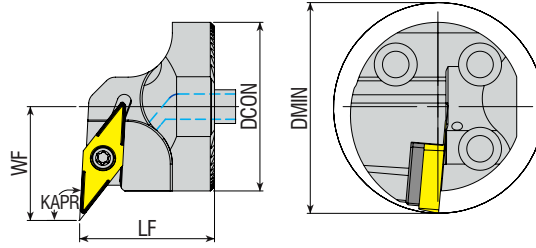

Código del Inserto
 Le Code de Commande
 Ordering Code

Stock
 Stock
 Stock

R L

DCON

Dimension (mm)
 Dimension (mm)
 Dimension (mm)

LF

WF

DMIN

Inserto
 Plaquette
 Insert



Recambios / Pièces de Rechange / Spare Parts

Tornillo
 Vis
 Screw



Cuñas
 Assise
 Shim

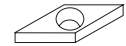

Tornillo de Placa
 Vis a Assise
 Shim Screw



Llave Torx
 Cle Torx
 Torx Wrench



ATTC-A20 SVUCR/L 11
 ATTC-A25 SVUCR/L 11
 ATTC-A32 SVUCR/L 16
 ATTC-A40 SVUCR/L 16

○ ○
 ○ ○
 ○ ○
 ● ●

20
 25
 32
 40

20
 23
 32
 32

15
 17
 22
 27

27
 32
 40
 50

VC.T 1103..
 VC.T 1604..

4008-M2.5x6
 4015-M3.5x14

-
 AAVN-2-0002

-
 AAV-06-M3.5x11

80-T08
 80-T15



KAPR=93°

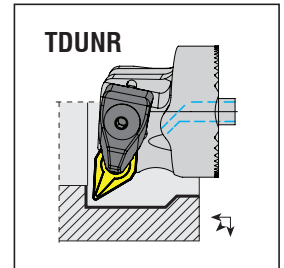
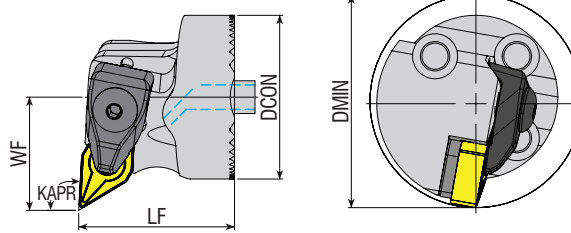

Código del Inserto
 Le Code de Commande
 Ordering Code

Stock
 Stock
 Stock

R L

DCON

Dimension (mm)
 Dimension (mm)
 Dimension (mm)

LF

WF

DMIN

Inserto
 Plaquette
 Insert



Abrazadera de Cuñas
 Mode de Fixation
 Wedge Clamp



Tornillo de Sujeción
 Vis de Fixation
 Wedge Screw



Cuñas
 Assise
 Shim



Tornillo de Placa
 Vis a Assise
 Shim Screw



Anillo
 Bague
 Ring



Arandela
 Timbre
 Washer



Llaves Allen
 Clés Allen
 Allen Wrench



ATTC-A32 TDUNR/L 11
 ATTC-A40 TDUNR/L 15

○ ○
 ● ●

32
 40

32
 38

22
 27

40
 50

DNM. 1104..
 DNM. 1506..

ATK-01
 ATK-02

AKV-01-M5x22
 AKV-30-M6x22

AADN-2-0001
 AADN-3-0001

AAV-04-M5x12
 AAV-02-M5x12

AS-01

ABPL-01

AAL-03-3

R: Derecha / Droite / Right L: Izquierda / Gauche / Left

● En Existencia / En stock / In Stock ○ Artículo sin Existencia / Indisponible en Stock / Non Stock Item

Ejemplo de Pedido / Exemple de Commande / Ordering Example

1 Piezas / pcs. / pcs. ATTC-A20 SVUCR 11

CARTUCHOS DE HERRAMIENTAS ANTI VIBRACIÒN
CARTOUCHE D'OUTILS ANTI VIBRATOIRES
ANTI VIBRATION TOOLS CARTRIDGES

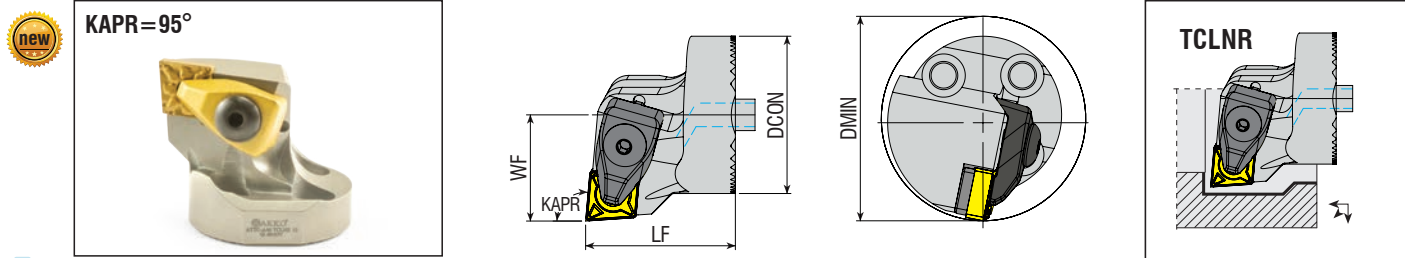

Código del Inserto Le Code de Commande Ordering Code	Stock Stock Stock		Dimension (mm) Dimension (mm) Dimension (mm)				Inserto Plaquette Insert	Recambios / Pièces de Rechange / Spare Parts						
	R	L	DCON	LF	WF	DMIN		Abrazadera de Cuñas Mode de Fixation Wedge Clamp	Tornillo de Sujeción Vis de Fixation Wedge Screw	Cuñas Assise Shim	Tornillo de Placa Vis a Assise Shim Screw	Anillo Bague Ring	Arandela Timbre Washer	Llaves Allen Clés Allen Allen Wrench
ATTC-A32 TCLNR/L 12	○	○	32	32	22	40	CNM. 1204..							
ATTC-A40 TCLNR/L 12	●	●	40	38	27	50		ATK-02	AKV-30-M6x22	AACN -3-0001	AAV-02-M5x12	AS-01	ABPL-01	AAL-03-3

INSTRUMENTO DE CENTRADO DE HERRAMIENTAS ANTIVIBRACIÒN
INSTRUMENT DE CENTRAGE D'OUTILS ANTI VIBRATOIRES
ANTI VIBRATION TOOLS CENTERING INSTRUMENT



Código del Inserto Le Code de Commande Ordering Code	Stock Stock Stock	Dimension (mm) Dimension (mm) Dimension (mm)				Art der Bohrstange Barre di Alesatura Body Type
		DCONWS	DCONMS	LF	H	
ATTC-16-25	●	28	25	15	22	 ATTB-D16/D20/D25 ATTB-D32/D40/D50/D60
ATTC-32-60	●	53	40	20	35	

R: Derecha / Droite / Right L: Izquierda / Gauche / Left

● En Existencia / En stock / In Stock ○ Artículo sin Existencia / Indisponible en Stock / Non Stock Item

Ejemplo de Pedido / Exemple de Commande / Ordering Example

1 Piezas / pcs. / pcs. ATTC-A32 TCLNR 12

1 Ensamblaje y Ajuste | Assemblage et Réglage | Assembly and Setting

Se debe limpiar la superficie del cartucho y el vástago a montar, así como la parte interna del portaherramientas. Verifique A y B en la imagen de abajo.

La surface de la cartouche et la tige à monter, ainsi que la partie intérieure du porte-outil doit être nettoyé. Voir A et B dans l'image de below./the tige et les surfaces de montage de la cartouche, en plus de l'intérieur du support, doit être nettoyé. Voir renvoie les surfaces sur les illustrations A et B.

The shank's and the cartridge's mounting surfaces, in addition to the inside of the holder, must be cleaned. See referred the surfaces on the illustrations A and B .

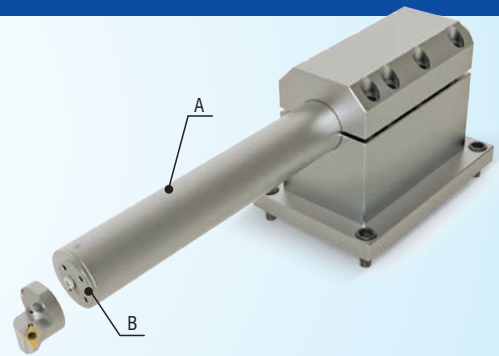

2 Ensamblaje Para el Mango | Assemblage et Montage de la Barre | Body Mounting

La longitud de sujeción no debe ser inferior a 4 L / D raio. Sugiera usar la cubierta de sujeción con el método de apertura y otros métodos de sujeción. (Tipo C). No utilice el método de sujeción por tornillo. Use enfriamiento interno por favor cuando trabaje mucho tiempo.

La longueur de serrage ne doit pas être Minumun 4xD. Suggere d'utiliser le couvercle de serrage avec la méthode d'ouverture et d'autres méthodes de serrage de maintien. (Type C). Ne pas utiliser la méthode de serrage à vis. Utiliser le refroidissement intérieur s'il vous plaît lorsque vous travaillez depuis longtemps.

The clamping length should not be Minumun 4xD. Suggest using the clamping cover with opening method and other holding clamping methods. (Type C). Do not use screw clamping method. Use inner cooling please when working a long time.

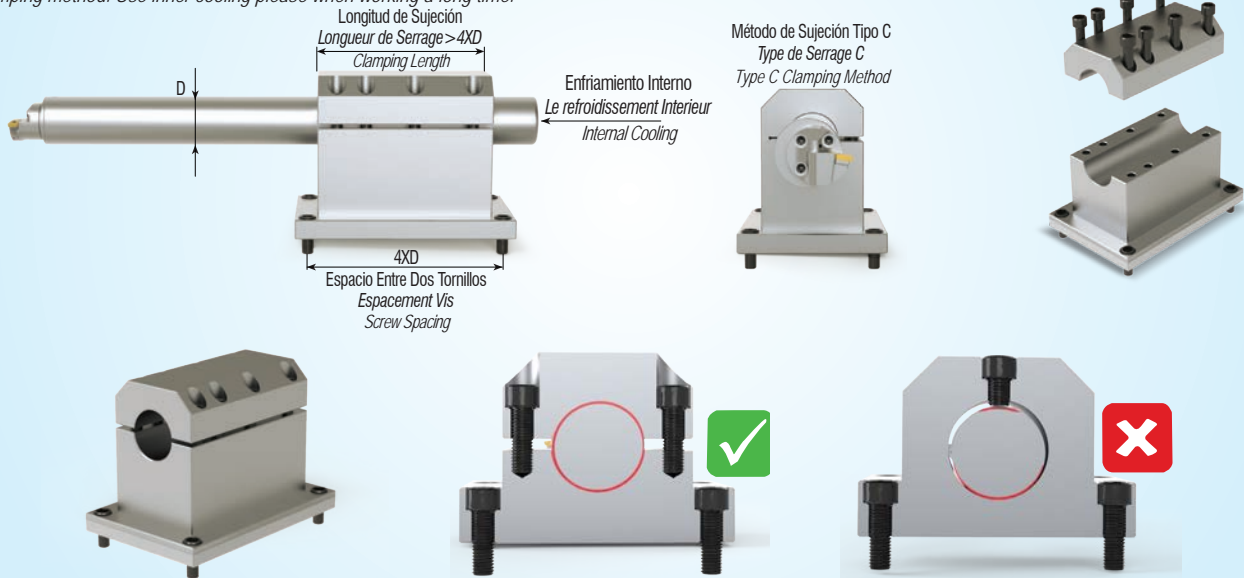

3 Ajuste de la Altura del Ensamblaje Central | Réglage de la Hauteur du Centre de Montage | Adjusting the Height of Centre Assembly

Al montar el cuerpo por primera vez, se debe utilizar una herramienta de calibración especial para la altura central. Primero monte el vástago en el soporte, luego calíbrelo con una tolerancia de 0.01 en la dirección del eje X. Realice el ajuste con el dispositivo indicador de cuadrante.

Lors du montage du corps pour la première fois, un outil d'étalonnage spécial doit être utilisé pour la hauteur du centre. Tout d'abord monter la tige sur le support, puis le calibre à l'intérieur de bod 0,01 tolérance sur la direction de l'axe X. S'il vous plaît effectuer le réglage avec le dispositif indicateur de cadran.

When mounting the body for the first time, a special calibration tool must be used for the center height. First mount the shank on the holder, then calibrate the bod within 0.01 tolerance on the X axis direction. Please make the adjustment with the dial indicator device.

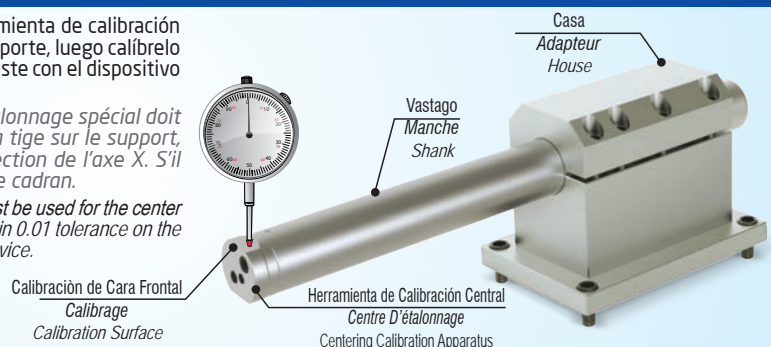

4 Ensamblar el Cartucho Correcto | Assemblée de la Cartouche Correcte | Correct Cartridge Mounting

Vea la Figura al Costado:
 Voir la Figure Sur le Côté:
 See The Figure on The Side:



Elegir el Inserto Correcto / Choisir la Bonne Plaquette / Choosing the Correct Insert

Elegir el inserto correcto puede tener una gran influencia en el éxito general de la amortiguación de vibraciones. La forma principal en que el inserto puede mejorar la estabilidad del mecanizado es minimizando las fuerzas de corte. Seguir las pautas a continuación debería ser su primer paso para eliminar las vibraciones: si es posible, utilícelo siempre con herramientas de perforación cortas. De lo contrario, reduzca sus velocidades para minimizar la vibración.

Le choix de l'insert correct peut avoir une grande influence sur le succès global de l'amortissement des vibrations. Le principal moyen de l'insert peut améliorer la stabilité d'usinage est en minimisant les efforts de coupe. En suivant les directives ci-dessous devrait être votre première étape pour éliminer les vibrations: Si possible, utilisez toujours courts outils de forage. Dans le cas contraire, réduire votre vitesse pour réduire au minimum vibration./Choosing l'insert droit a un impact majeur sur le succès global de l'amortissement des vibrations. Le principal moyen de l'insert peut améliorer la stabilité d'usinage est de minimiser les efforts de coupe. pour éliminer les vibrations: utilisation des outils courts et diminuer l'accélération, autant que possible. Choosing the right insert has a major impact on the overall success of vibration damping. The main way the insert can improve machining stability is to minimize the cutting forces. to eliminate the vibrations: use short tools and Decrease the acceleration as much as possible.

A Elija un ángulo de entrada lo más cercano posible a 90° para reducir las fuerzas radiales al mínimo.
 Choisir un outil avec un angle d'entrée qui est aussi proche que possible de 90° afin de réduire les forces radiales à un minimum.
 Choose a tool with an entry angle that is as close as possible to 90° to reduce the radial forces to a minimum.

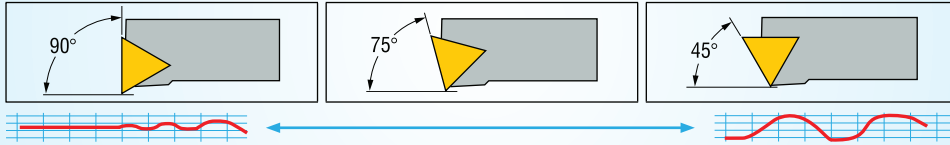

B Elija el ángulo de cabeza de inserción más pequeño posible. Esto reducirá las fuerzas generales de corte y aumentará el espacio libre.
 Choisissez l'angle de la tête d'insertion le plus petit possible. Cela permettra de réduire les forces globales de coupe et d'augmenter la qualité de surface.
 Choose the smallest insert head angle possible. This will reduce overall cutting forces and increase the surface quality.

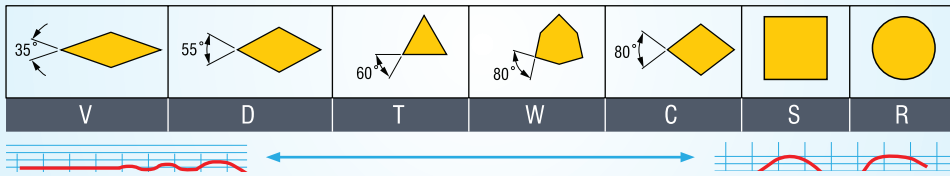

C Elija un radio de punta pequeño para reducir las fuerzas de corte y permitir el mecanizado en una profundidad de corte más baja.
 Choisissez un petit rayon de nez pour réduire les forces de coupe et pour permettre l'usinage d'une profondeur inférieure de cut.
 Choose a small nose radius to reduce the cutting forces and to enable machining in a lower depth of cut. To reduce the vibration, choose the smallest nose radius insert as possible.

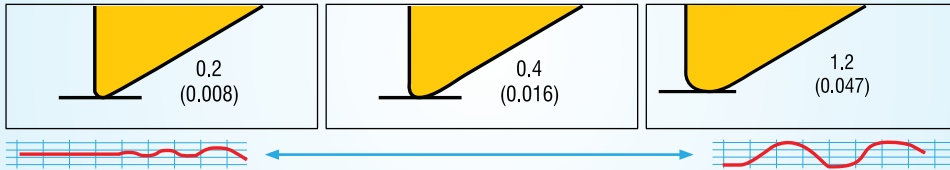

D La profundidad de mecanizado (ap) debe ser mayor que el radio de la punta.
 La profondeur d'usinage (ap) doit être supérieure au rayon du nez.
 Machining depth (ap) should be larger than the nose radius.

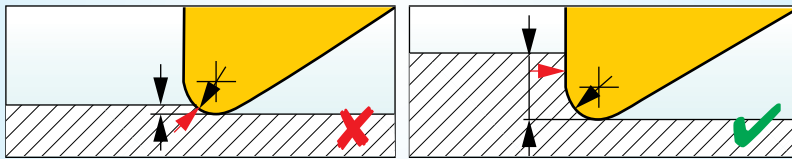

E Use un inserto con una geometría positiva general para reducir las fuerzas de corte:
 Utilisation d'un insert avec une géométrie positive globale à réduire les forces de coupe:
 Use an insert with an overall positive geometry to reduce the cutting forces:

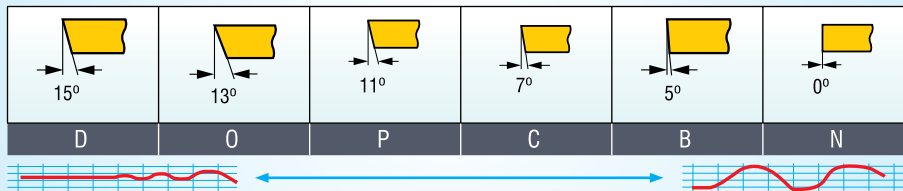

F Elija una geometría de rastrillo superior positiva:
 Choisir une géométrie de coupe positif haut:
 Choose a positive top rake geometry:

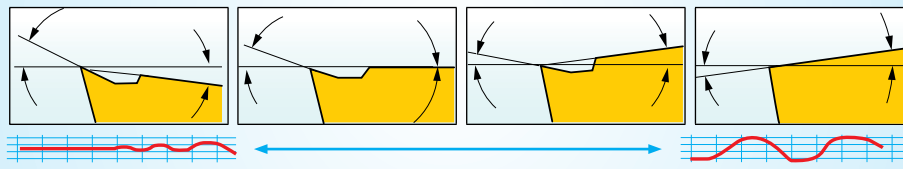

G For-dampened-straight-adaptor:

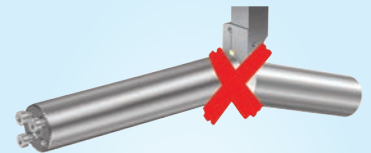

L, longitud mínima después del corte
 L, longueur min après coupure
 L, min length after cut off

Ø	Diseño Corto Conception Courte Short Design 4-7x Ø (mm)	Diseño Largo Conception Longue Long Design 7-10x Ø (mm)
16	100	155
20	125	200
25	155	255
32	190	320
40	240	410
50	305	520
60	380	630



konusulan
the spoken kalite...
quality...

CARTRIDGE

CARTUCHO
CARTOUCHE
CARTRIDGE





S
T
F
C
R
12
C
A
16

1 Método de Montaje del Inserto / Méthode de Montage de Plaquette / Clamping Method of Insert

 Sujeción Superior Sin Orificio Fixation Par Bride Top Clamping Without Hole	 Orificio de Sujeción (Bloqueo de Palanca) Fixation Par Trou Central (Lever de Verrouillage) Hole Clamping (Lever Lock)	 Atornillar Fixation Par Vis Screw on
C	P	S



2 Forma de Inserto / Forme de Plaquette / Insert Shape

 C	 S	 T
---	---	---

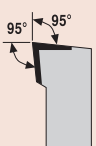
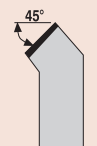
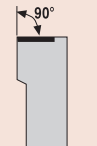
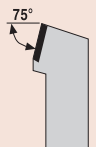
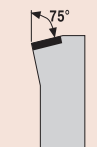
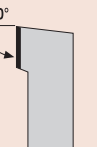
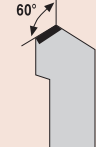
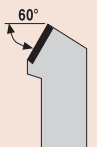
3 Portaherramientas Forma Geométrica de la Barra / Angle D'attaque / Tool Holder Shape Bar Geometry

 L	 S	 F
 R	 K	 G
 W	 T	

4 Inserto de ángulo libre Frietwinkel / Angle de Deposite de L'arete de Coupe Principale / Insert Clearance Ange Freiwinkel

 C	 P	 N
---	---	---

5 Dirección de Corte / Direction de Coupe / Cutting Direction

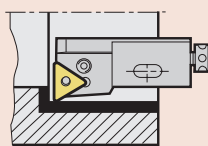
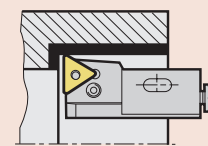
 R	 L
--	---

6 Altura del Filo / Hauteur de L'outil / Cutting Edge Height

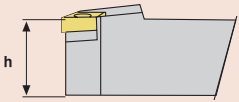
h



7 Código de Cartucho / Code de Cartouche / Cartridge Code

C
(Cartucho / Cartouche / Cartridge)

8 Tipo de Cartucho / Type de Cartouche / Cartridge Type

A
(ISO 5611)

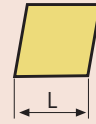
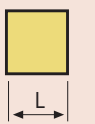
9 Longitud del Filo / Longueur de Coupe / Cutting Edge Length

 L	 L	 L
--	---	---



KAPR=90°

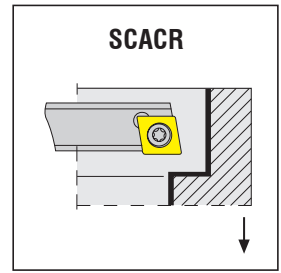
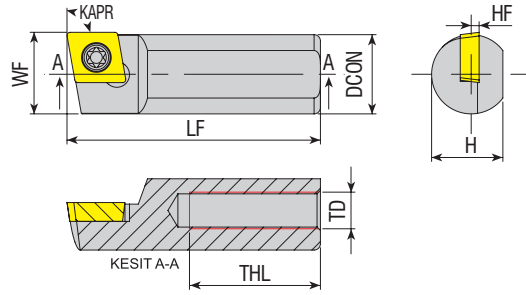

Código del Inserto
 Le Code de Commande
 Ordering Code

Stock
 Stock
 Stock

Dimension (mm)
 Dimension (mm)
 Dimension (mm)

Inserto
 Plaquette
 Insert

Recambios / Pièces de Rechange / Spare Parts

Tornillo
 Vis
 Screw

Llave Torx
 Clé Torx
 Torx Wrench

R L DCON H LF THL HF WF TD



S10X SCACR/L 06	●	●	10	9	25	10	1	10.3	M5x0.8
S10A SCACR/L 06	●	●	10	9	32	15	1	10.3	M5x0.8
S1018 SCACR/L 06	○	●	10	9	18	8	1	9.8	M5x0.8
S1065 SCACR/L 06	○	●	10	9	65	25	1	10.3	M5x0.8
S10C SCACR/L 06	●	●	10	9	50	25	1	10.3	M5x0.8
S12B SCACR/L 06	●	●	12	11	40	25	1	12.3	M5x0.8
S12D SCACR/L 06	●	●	12	11	60	25	1	12.3	M5x0.8
S12D SCACR/L 09	●	●	12	11	60	25	2	12.2	M5x0.8
S1265 SCACR/L 09	○	●	12	11	65	25	2	12.3	M5x0.8
S12H SCACR/L 09	●	●	12	11	100	25	2	12.2	M5x0.8
S15C SCACR/L 09	●	●	15	14	50	25	2	15.3	M8x1.25
S1554 SCACR/L 09	○	●	15	14	54	25	2	15.3	M8x1.25
S15E SCACR/L 09	○	●	15	14	70	45	2	15.3	M8x1.25
S15D SCACR/L 09	○	●	15	14	60	30	2	15.3	M8x1.25
S16A SCACR/L 09	●	●	16	15	32	15	2	16.5	M6x1
S16B SCACR/L 09	●	●	16	15	40	20	2	16.5	M6x1
S16C SCACR/L 09	○	●	16	15	50	25	2	16.5	M6x1
S16D SCACR/L 09	●	●	16	15	60	30	2	16.5	M6x1
S16E SCACR/L 09	○	●	16	15	70	30	2	16.5	M6x1
S16G SCACR/L 09	●	●	16	15	90	30	2	16.5	M6x1
S16H SCACR/L 09	○	●	16	15	100	35	4	16.5	M6x1
S1868 SCACR/L 09	○	●	18	17	68	30	2	18.5	M8x1.25
S18E SCACR/L 09	●	●	18	17	70	30	2	18.5	M8x1.25
S1888 SCACR/L 09	○	●	18	17	88	30	2	18.5	M8x1.25
S18105 SCACR/L 09	○	●	18	17	105	30	2	18.5	M8x1.25
S18175 SCACR/L 09	○	●	18	17	175	30	2	18.5	M8x1.25
S20E SCACR/L 09	●	●	20	18.3	70	30	2	20.5	M6x1
S20E SCACR/L 12	●	●	20	18.3	70	30	2	20.5	M6x1
S20H SCACR/L 12	●	●	20	18.3	100	30	2	20.5	M6x1

CC.T 0602..

4008-M2.5x6

80-T08

CC.T 09T3..

4015-M3.5x8

80-T15

CC.T 1204..

1020-M5x11

80-T20



R: Derecha / Droite / Right L: Izquierda / Gauche / Left

● En Existencia / En stock / In Stock ○ Artículo sin Existencia / Indisponible en Stock / Non Stock Item

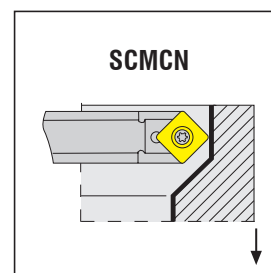
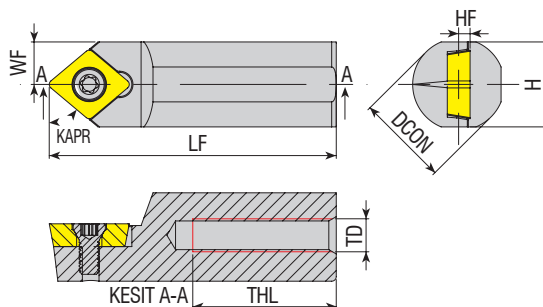

Ejemplo de Pedido / Exemple de Commande / Ordering Example

1 Piezas / pcs. / pcs. S10X SCACR 06

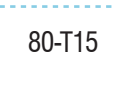

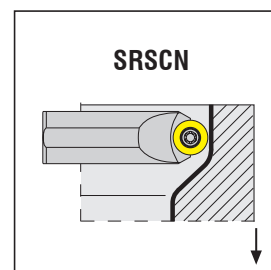
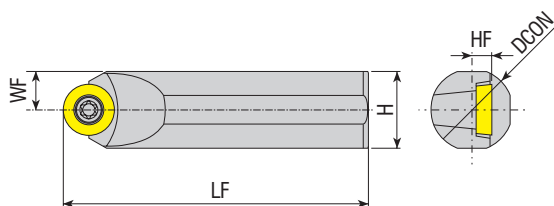
Código del Inserto Le Code de Commande Ordering Code	Stock Stock Stock	Dimension (mm) Dimension (mm) Dimension (mm)							Inserto Plaque Insert	Recambios / Pièces de Rechange / Spare Parts	
		DCON	H	LF	THL	HF	WF	TD		Tornillo Vis Screw	Llave Torx Clé Torx Torx Wrench
S10X SCMCN 06	●	10	9	25	10	1	5	M5x0.8			
S12D SCMCN 06	●	12	11	60	25	1	6	M5x0.8			
S16C SCMCN 09	●	16	15	50	25	2	8	M6x1			
S16D SCMCN 09	●	16	15	60	25	4	8	M6x1			



Código del Inserto Le Code de Commande Ordering Code	Stock Stock Stock	Dimension (mm) Dimension (mm) Dimension (mm)					Inserto Plaque Insert	Recambios / Pièces de Rechange / Spare Parts	
		DCON	H	WF	HF	LF		Tornillo Vis Screw	Llave Torx Clé Torx Torx Wrench
S12D SRSCN 10	●	12	11	6	3.9	60			
S14D SRSCN 10	●	14	13	7	3.9	60			
S16D SRSCN 10	●	16	15	8	3.9	60			

R: Derecha / Droite / Right L: Izquierda / Gauche / Left

● En Existencia / En stock / In Stock ○ Artículo sin Existencia / Indisponible en Stock / Non Stock Item

Ejemplo de Pedido / Exemple de Commande / Ordering Example

1 Piezas / pcs. / pcs. S10X SCMCN 06

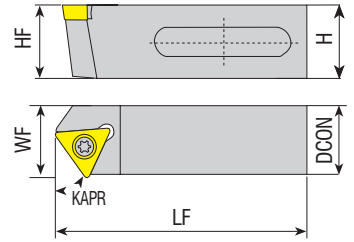

Código del Inserto Le Code de Commande Ordering Code	Stock		Dimension (mm) Dimension (mm)					Inserto Plaquette Insert	Recambios / Pièces de Rechange / Spare Parts		
	R	L	DCON	H	HF	LF	WF		Tornillo Vis Screw	Llave Torx Clé Torx Torx Wrench	
	○	●									
STXCR/L 2020 B16	○	●	20	20	20	45	20	TC.. 16T3..			
STXCR/L 2020 E16	○	●	20	20	20	70	20				
STXCR/L 2020 B16-SA	○	●	20	10	20	45	20				
STXCR/L 2020 E16-SA	○	●	20	10	20	70	20				
STXCR/L 2020 B16-PL	○	●	20	10	20	45	20				
STXCR/L 2020 E16-PL	○	●	20	10	20	70	20				
STXCR/L 2020 H16-PL	○	●	20	10	20	100	20				

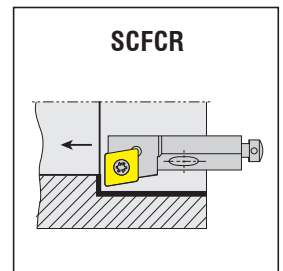
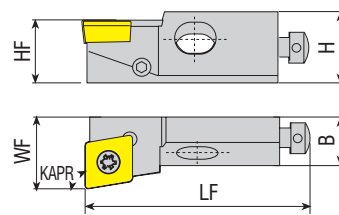
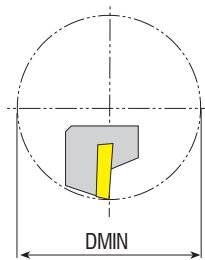

Código del Inserto Le Code de Commande Ordering Code	Stock		Dimension (mm) Dimension (mm)						Inserto Plaquette Insert	Recambios / Pièces de Rechange / Spare Parts			
	R	L	HF	H	B	LF	WF	DMIN		Cuñas Assise Shim	Tornillo de Placa Vis a Assise Shim Screw	Tornillo Vis Screw	Llave Torx Clé Torx Torx Wrench
	○	●											
SCFCR/L 06CA 06	●	●	6	8.5	6	25	8	≥20	CC.T 060204	-	-	4008-M2.5x6	80-T08
SCFCR/L 08CA 06	●	●	8	11	8	32	10	≥25					
SCFCR/L 10CA 09	●	●	10	15	11	50	14	≥40	CC.T 09T308	-	-	4015-M3.5x9	80-T15
SCFCR/L 12CA 12	●	○	12	20	15	55	20	≥50					
SCFCR/L 16CA 12	●	●	16	21	20	63	25	≥60	CC.T 120408	AACN-2-0003	AAV-10-M4.5x8	4020-M4.5x12	80-T20

R: Derecha / Droite / Right L: Izquierda / Gauche / Left

● En Existencia / En stock / In Stock ○ Artículo sin Existencia / Indisponible en Stock / Non Stock Item

Ejemplo de Pedido / Exemple de Commande / Ordering Example

1 Piezas / pcs. / pcs. STXCR 2020 B16

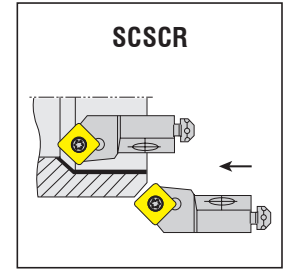
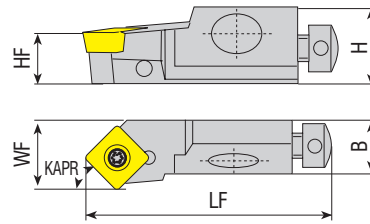
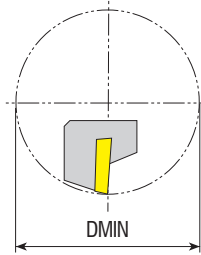

Código del Inserto Le Code de Commande Ordering Code	Stock		Dimension (mm) Dimension (mm)					Inserto Plaquette Insert	Recambios / Pièces de Rechange / Spare Parts				
	R	L	HF	H	B	LF	WF		DMIN	Cuñas Assise Shim	Tornillo de Placa Vis a Assise Shim Screw	Tornillo Vis Screw	Llave Torx Clé Torx Torx Wrench
SCSCR/L 06CA 06	●	○	6	8	6	30	8	≥20		-	-	4008-M2.5x6	80-T08
SCSCR/L 10CA 09	●	○	10	15	11	50	14	≥40		-	-	4015-M3.5x9	80-T15
SCSCR/L 12CA 12	○	○	12	20	15	55	20	≥50		-	-	1020-M5x11	80-T20

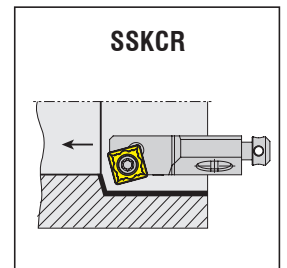
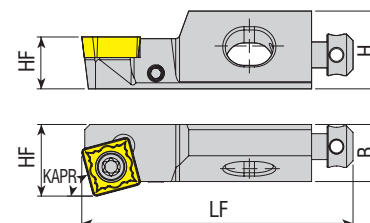
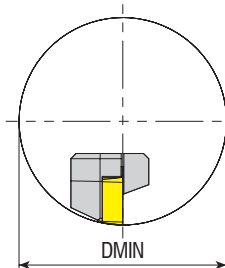

Código del Inserto Le Code de Commande Ordering Code	Stock		Dimension (mm) Dimension (mm)					Inserto Plaquette Insert	Recambios / Pièces de Rechange / Spare Parts				
	R	L	HF	H	B	LF	WF		DMIN	Cuñas Assise Shim	Tornillo de Placa Vis a Assise Shim Screw	Tornillo Vis Screw	Llave Torx Clé Torx Torx Wrench
SSKCR/L 10CA 09	●	○	10	15	11	50	14	≥40		-	-	4015-M3.5x9	80-T15
SSKCR/L 12CA 12	●	○	12	20	15	55	20	≥50		-	-	1020-M5x11	80-T20

R: Derecha / Droite / Right L: Izquierda / Gauche / Left

● En Existencia / En stock / In Stock ○ Artículo sin Existencia / Indisponible en Stock / Non Stock Item

Ejemplo de Pedido / Exemple de Commande / Ordering Example

1 Piezas / pcs. / pcs. SCSCR 06CA 06

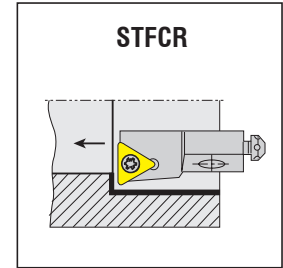
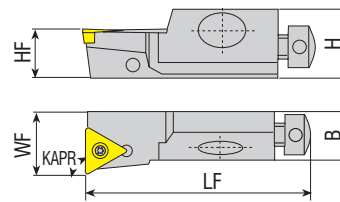
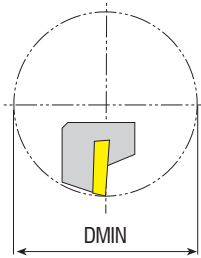

Código del Inserto Le Code de Commande Ordering Code	Stock		Dimension (mm) Dimension (mm) Dimension (mm)						Inserto Plaque Insert	Recambios / Pièces de Rechange / Spare Parts			
	R	L	HF	H	B	LF	WF	DMIN		Cuñas Assise Shim	Tornillo de Placa Vis a Assise Shim Screw	Tornillo Vis Screw	Llave Torx Cle Torx Torx Wrench
STFCR/L 08CA 09	●	●	8	11	8	32	10	≥25	TC.T 090204 TC.T 110204 TC.T 16T308	-	-	3007-M2.2x5	80-T07
STFCR/L 10CA 11	●	●	10	15	11	50	14	≥40		-	-	4008-M2.5x6	80-T08
STFCR/L 12CA 16	●	○	12	20	15	55	20	≥50		-	-	4015-M3.5x11	80-T15
STFCR/L 16CA 16	●	●	16	21	20	63	25	≥60		AATN-2-0001	AAV-06-M3.5x11	4015-M3.5x14	

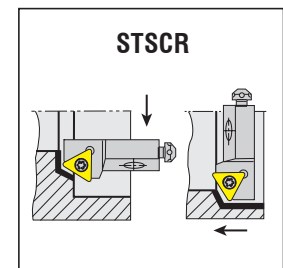
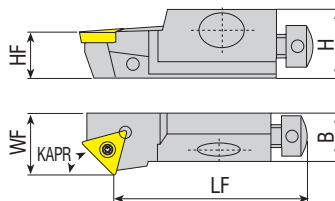
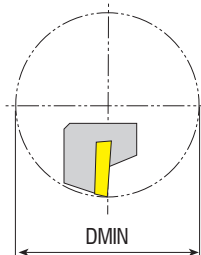

Código del Inserto Le Code de Commande Ordering Code	Stock		Dimension (mm) Dimension (mm) Dimension (mm)						Inserto Plaque Insert	Recambios / Pièces de Rechange / Spare Parts			
	R	L	HF	H	B	LF	WF	DMIN		Cuñas Assise Shim	Tornillo de Placa Vis a Assise Shim Screw	Tornillo Vis Screw	Llave Torx Cle Torx Torx Wrench
STSCR/L 08CA 09	●	○	8	11	8	28	10	≥25	TC.T 090204 TC.T 110204 TC.T 16T308	-	-	3007-M2.2x5	80-T07
STSCR/L 10CA 11	●	●	10	15	11	44	14	≥40		-	-	4008-M2.5x6	80-T08
STSCR/L 12CA 16	●	○	12	20	15	47	20	≥50		-	-	4015-M3.5x11	80-T15

R: Derecha / Droite / Right L: Izquierda / Gauche / Left

● En Existencia / En stock / In Stock ○ Artículo sin Existencia / Indisponible en Stock / Non Stock Item

Ejemplo de Pedido / Exemple de Commande / Ordering Example

1 Piezas / pcs. / pcs. STFCR 08CA 09

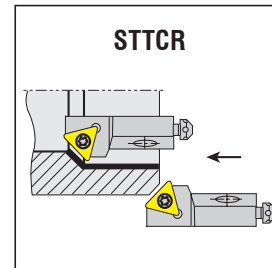
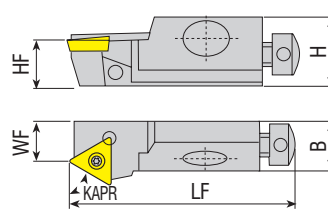
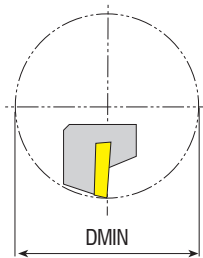

Código del Inserto Le Code de Commande Ordering Code	Stock Stock		Dimension (mm) Dimension (mm)					Inserto Plaquette Insert	Recambios / Pièces de Rechange / Spare Parts				
	R	L	HF	H	B	LF	WF		DMIN	Cuñas Assise Shim	Tornillo de Placa Vis a Assise Shim Screw	Tornillo Vis Screw	Llave Torx Clé Torx Torx Wrench
STTCR/L 08CA 09	●	●	8	11	8	32	6	≥25					
STTCR/L 10CA 11	●	●	10	15	11	50	9	≥40		-	-	3007-M2.2x5	80-T07
										-	-	4008-M2.5x6	80-T08

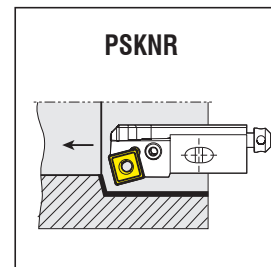
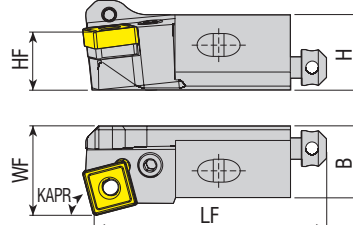
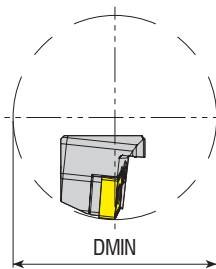

Código del Inserto Le Code de Commande Ordering Code	Stock Stock		Dimension (mm) Dimension (mm)					Inserto Plaquette Insert	Recambios / Pièces de Rechange / Spare Parts					
	R	L	HF	H	B	LF	WF		DMIN	Palanca Lever Lever	Tornillo de Palanca Lever Vis Lever Screw	Cuñas Assise Shim	Cuñas Resorte Ressort a Cale Shim Spring	Llaves Allen Cles Allen Allen Wrench
PSKNR/L 16CA 12	●	●	16	21	20	63	25	≥60						

R: Derecha / Droite / Right L: Izquierda / Gauche / Left

● En Existencia / En stock / In Stock ○ Artículo sin Existencia / Indisponible en Stock / Non Stock Item

Ejemplo de Pedido / Exemple de Commande / Ordering Example

1 Piezas / pcs. / pcs. STTCR 08CA 09

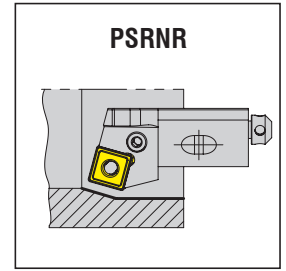
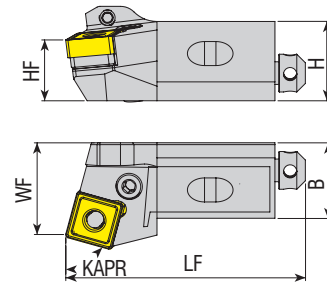
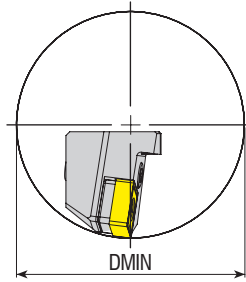

Código del Inserto Le Code de Commande Ordering Code	Stock		Dimension (mm) Dimension (mm) Dimension (mm)						Inserto Plaquette Insert	Recambios / Pièces de Rechange / Spare Parts				
	R	L	HF	H	B	LF	WF	DMIN		Palanca Lever	Tornillo de Palanca Lever Vis Lever Screw	Cuñas Assise Shim	Cuñas Resorte Resort a Cale Shim Spring	Llaves Allen Clés Allen Allen Wrench
PSRNR/L 16CA 12	○	●	16	21	20	63	25	≥60						

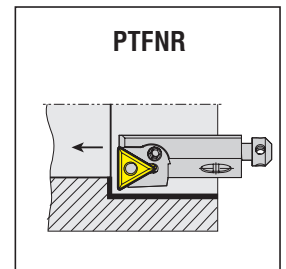
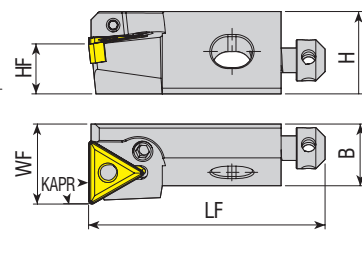
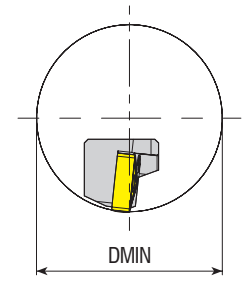

Código del Inserto Le Code de Commande Ordering Code	Stock		Dimension (mm) Dimension (mm) Dimension (mm)						Inserto Plaquette Insert	Recambios / Pièces de Rechange / Spare Parts				
	R	L	HF	H	B	LF	WF	DMIN		Palanca Lever	Tornillo de Palanca Lever Vis Lever Screw	Cuñas Assise Shim	Cuñas Resorte Resort a Cale Shim Spring	Llaves Allen Clés Allen Allen Wrench
PTFNR/L 12CA 16	●	●	12	20	15	47	20	≥50				-		
PTFNR/L 16CA 16	●	○	16	21	20	63	25	≥60						

R: Derecha / Droite / Right L: Izquierda / Gauche / Left

● En Existencia / En stock / In Stock ○ Artículo sin Existencia / Indisponible en Stock / Non Stock Item

Ejemplo de Pedido / Exemple de Commande / Ordering Example

1 Piezas / pcs. / pcs. PSRNR 16CA 12



KAPR=45°

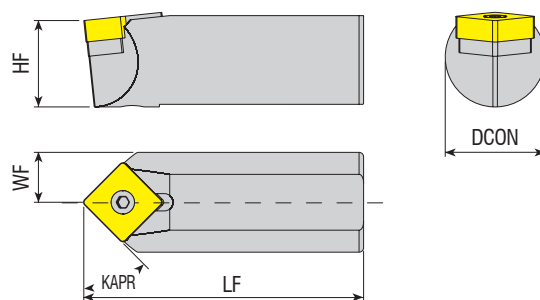

Código del Inserto Le Code de Commande Ordering Code	Stock Stock	Dimension (mm) Dimension (mm)				Inserto Plaquette Insert	Recambios / Pièces de Rechange / Spare Parts				
		DCON	HF	LF	WF		Cuñas Assise Shim	Tornillo Vis Screw	Abrazadera de Cuñas Mode de Fixation Wedge Clamp	Tornillo de Sujeción Vis de Fixation Wedge Screw	Llaves Allen Clés Allen Allen Wrench
S22D PSDNN 12C	●	22	19.5	65	11						

R: Derecha / Droite / Right L: Izquierda / Gauche / Left

● En Existencia / En stock / In Stock ○ Artículo sin Existencia / Indisponible en Stock / Non Stock Item

Ejemplo de Pedido / Exemple de Commande / Ordering Example

1 Piezas / pcs. / pcs. S22D PSDNN 12C

PIEZAS DE RECAMBIO DE CARTUCHO
PIÈCES DE RECHANGE DE CARTOUCHE
CARTRIDGE SPARE PARTS

Código del Inserto Le Code de Commande Ordering Code	Recambios / Pièces de Rechange / Spare Parts					
	Axial Adj. Tornillo Axiale Adj. Vis Axial Adjust Screw	Radial Adj. Tornillo Radiale Adj. Vis Radial Adjust Screw	Radial Adj. Tornillo Llave Allen Radiale Adj. Vis Clé Allen Radial Adjust Screw Wrench	Tornillo de Fijación Vis de Fixation Mounting Screw	Tornillo de Montaje Llave Allen Vis de Montage Clé Allen Mounting Screw Wrench	
SCFCR/L	06CA 06	2600-M4x9.5	2715-M3x5	AAL-09-1.5	AKV-23-M4x10	AAL-03-3
SCSCR/L	08CA 06	2600-M4x9.5	2715-M3x5	AAL-09-1.5	AKV-23-M4x10	AAL-03-3
SSKCR/L	10CA 09	2600-M5x13	2702-M4x10	AAL-01-2	2505-M6x16	AAL-03-3
	12CA 12	2600-M5x13	2702-M4x10	AAL-01-2	2505-M6x16	AAL-03-3
	16CA 12	2600-M6x18	2725-M5x12	AAL-02-2.5	2005-M8x25	AAL-07-5
STSCR/L	08CA 09	2600-M4x9.5	2715-M3x5	AAL-09-1.5	AKV-23-M4x10	AAL-03-3
STTCR/L	10CA 11	2600-M5x13	2702-M4x10	AAL-01-2	2505-M6x16	AAL-03-3
STFCR/L	12CA 16	2600-M5x13	2702-M4x10	AAL-01-2	2505-M6x16	AAL-03-3
	16CA 16	2600-M6x18	2725-M5x12	AAL-02-2.5	2005-M8x25	AAL-07-5
PTFNR/L	12CA 16	2600-M5x13	2702-M4x4	AAL-01-2	2505-M6x16	AAL-03-3
PSKNR/L	16CA 16	2600-M6x18	2725-M5x6	AAL-02-2.5	2005-M8x25	AAL-07-5
PSRNR/L	16CA 12	2600-M6x18	2725-M5x6	AAL-02-2.5	2005-M8x25	AAL-07-5



Código del Inserto Le Code de Commande Ordering Code	Stock Stock Stock	Rango de Perforación (mm) Plage de Perçage (mm) Size Range (mm)					Cartucho Cartouche Cartridge	Código del Cuerpo de la Herramienta Body Code de l'outil Body Tool Code	Dibujo Técnico Dessin Technique Technical Drawing
		D max		D min		Max (D out-D in)			
		D in	D out	D in	D out				
ACPBT-1	●	27-52	52	18-36	36	27	ÖTG-K-120-20		
ACPBT-2	●	27-49	52	25-36	36	27			
ACPBT-3	●	48-75	75	41	42	27			
ACPBT-4	●	51-75	75	51	52	27			
ACPBT-5	●	22-35	35	22	23	27			
ACPBT-6	●	15-35	35	15	16	27			
ACPBT-7	●	49-53	75	32-36	36	27			
ACPBT-8	●	49	75	33-37	37	27			

Código del Inserto Le Code de Commande Ordering Code	Stock Stock Stock	Rango de Perforación (mm) Plage de Perçage (mm) Size Range (mm)					Cartucho Cartouche Cartridge	Código del Cuerpo de la Herramienta Body Code de l'outil Body Tool Code	Dibujo Técnico Dessin Technique Technical Drawing
		D1		D2		Max (D dis-D ic) (D out-D in)			
		D max	D min	D max	D min				
ACPBT-9	●	38	24	15	1	-	ÖTG-K-120-20		
ACPBT-10	●	78	64	43	29	-			

R: Derecha / Droite / Right L: Izquierda / Gauche / Left

● En Existencia / En stock / In Stock ○ Artículo sin Existencia / Indisponible en Stock / Non Stock Item

Ejemplo de Pedido / Exemple de Commande / Ordering Example

1 Piezas / pcs. / pcs. ACPBT-1



*konusulan
the spoken kalite...
quality...*

THREADING

PORTA HERRAMIENTAS DE ROSCADO
PORTE-OUTILS A FILETER
THREADING TOOLHOLDERS





S **E** **R** **25 25** **M** **16** **C**

1 Método de Montaje del Inserto / Méthode de Montage de Plaquette
 Clamping Method of Insert

S: Tornillo de Sujeción
 S: Vis de Fixation / S: Screw Clamping
 T: Tornillo de Sujeción Con Angulo de Hélice
 T: Vis de Fixation Avec Angle D'hélice
 T: Screw Clamping with Helix Angle

2 Solicitud / Application
 Application Type

E: Externo / Exterieur
 External
 I: Interno / Interieur
 Internal

3 Dirección de Corte
 Sens de Coupe
 Cutting Direction

R: Mano Derecha L: Mano Izquierda
 R: Main Droite L: Main Gauche
 R: Right-Hand L: Left-Hand

4 Tipo de Mandrinadores / Type de Barre D'alésage / Type of Boring Bar

"A" Acero Sólido con Orificio de Refrigerante / "A" En Acier Massif Avec Trou d'arrosage
 "A" Solid Steel with Coolant Hole
 "E" Barra de Carburo con Cabezal de Acero Fijo y Orificio de Refrigerante / "E" Avec Barre Carbide Tête Fixe en Acier et Un Trou de Fluide de Refroidissement
 "E" Carbide Bar with Fixed Steel Head and Coolant Hole
 "C" Mango de Carburo / "C" Tige Carbide / "C" Carbide Shank
 "S" Vástago de Acero / "S" Tige en Acier / "S" Steel Shank

4-5 Siz Externo del Vástago
 Dimensions du Jarret
 External Shank Siz

Mango / Jarret / Shank : hxb
 2525 - 25 x 25 mm

5 Diámetro del Vástago / Diamètre de la Tige
 Shank Diameter

6 Longitud del Vástago / Longueur de L'outil LF(mm) / Shank Length

A - 32	H - 100	Q - 180	x-special
B - 40	J - 110	R - 200	
C - 50	K - 125	S - 250	
D - 60	L - 140	T - 300	
E - 70	M - 150	U - 350	
F - 80	N - 160	V - 400	
G - 90	P - 170	W - 450	

7 Tamañ del Inserto / Taille de Plaquette
 Insert Size

l (mm)	d
06	5/32"
08	3/16"
11	1/4"
16	3/8"
22	1/2"
27	5/8"

8 Abrazadera de Cuñas
 Mode de Fixation
 Wedge Clamp

S **I** **R** **S** **25** **R** **16** **C**

PORTA HERRAMIENTAS DE ROSCADO EXTERNO
 PORTE-OUTILS A FILETER EXTERIEUR
 EXTERNAL THREADING TOOLHOLDERS

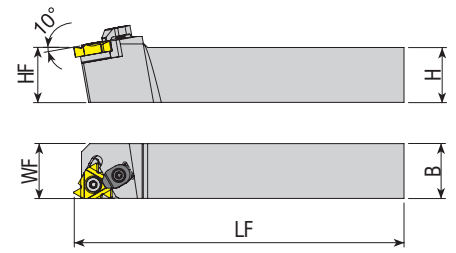
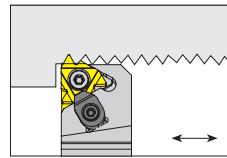
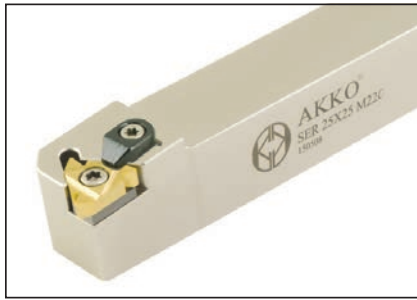

Código del Inserto Le Code de Commande Ordering Code	Stock Stock		Dimension (mm) Dimension (mm) Dimension (mm)				Inserto Plaquette Insert	Recambios / Pièces de Rechange / Spare Parts					
	R	L	HF=H	B	LF	WF		Tornillo Vis Screw	Cuñas Assise Shim	Tornillo de Placa Vis a Assise Shim Screw	Abrazadera de Cuñas Mode de Fixation Wedge Clamp	Tornillo de Sujeción Vis de Fixation Wedge Screw	Llave Torx Clé Torx Torx Wrench
SER/L 0808 E11	●	●	08	08	70	11	11 ER/EL	4008-M2.5x6	-	-	-	-	80-T08
SER/L 1010 E11	●	●	10	10	70	11							
SER/L 1212 F11	●	●	12	12	80	12							
SER/L 1616 H11	●	●	16	16	100	16							
SER/L 2020 H11	●	●	20	20	100	20							
SER/L 1616 H16C	●	●	16	16	100	16	16 ER/EL (0.35 - 3) ISO METRIC	4015-M3.5x14	AATN-2-0020	AAV-06-M3.5x11	-	-	80-T15
SER/L 2020 K16C	●	●	20	20	125	20							
SER/L 2525 M16C	●	●	25	25	150	25							
SER/L 3232 P16C	●	●	32	32	170	32	22 ER/EL (3.5 - 4.5) ISO METRIC	1020-M4.5x16	AATN-2-0004	AAV-07-M4.5x13	ACK-05	4015 M4x11	80-T20
SER/L 2525 M22C	●	●	25	25	150	25							
SER/L 3232 P22C	●	●	32	32	170	32	16 ER/L (1.5-3 TR)	4015-M3.5x14	-	-	-	-	80-T15
SER/L 4040 S22C	●	●	40	40	250	40							
SER/L 2525 M16C-T	●	●	25	25	150	25	22 ER/L (4-6 TR)	1020-M4.5x16	-	-	-	-	80-T20
SER/L 2020 K16C-S	●	●	20	20	125	25	SNDVK 166 ER/L16	4015-M3.5x14	AATN-2-0020	AAV-06-M3.5x11	-	-	80-T15
SER/L 2525 M16C-S	●	●	25	25	150	31							
SER/L 3232 P16C-S	●	●	32	32	170	38.5							

PORTA HERRAMIENTAS DE ROSCADO EXTERNO PARA TORNOS AUTOMÁTICOS CORREDIZO TIPO SUIZO
 PORTE-OUTILS DE RAINURAGE EXTERIEUR POUR MACHINES DE TYPES SWISS
 EXTERNAL THREADING TOOLHOLDERS FOR SWISS TYPE SLIDING AUTOMATIC LATHES

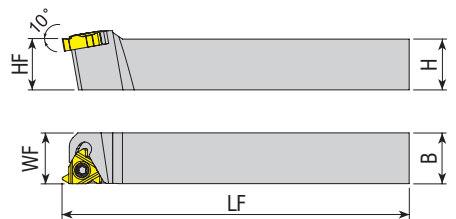
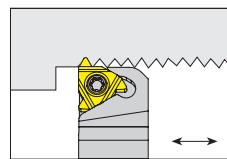

Código del Inserto Le Code de Commande Ordering Code	Stock Stock		Dimension (mm) Dimension (mm) Dimension (mm)				Inserto Plaquette Insert	Recambios / Pièces de Rechange / Spare Parts					
	R	L	HF=H	B	LF	WF		Tornillo Vis Screw	Cuñas Assise Shim	Tornillo de Placa Vis a Assise Shim Screw	Abrazadera de Cuñas Mode de Fixation Wedge Clamp	Tornillo de Sujeción Vis de Fixation Wedge Screw	Llave Torx Clé Torx Torx Wrench
SER/L 1010 K11-S	●	●	10	10	125	10	11 ER/EL	4008-M2.5x6	-	-	-	-	80-T08
SER/L 1212 K11-S	●	●	12	12	125	12							

R: Derecha / Droite / Right L: Izquierda / Gauche / Left

● En Existencia / En stock / In Stock ○ Artículo sin Existencia / Indisponible en Stock / Non Stock Item

Las herramientas tienen un ángulo de hélice de 1.5° incorporado. / Les outils ont un construit en angle d'hélice de 1,5°. / The tools have a built in 1.5° helix angle.

ADVERTENCIA / ATTENTION / WARNING: P130; La operación para B y D en la página 130 no se puede aplicar. / L'opération B et D à la page 130 ne peut pas être appliquée. / The operation for B and D on page 130 can not be applied.

Ejemplo de Pedido / Exemple de Commande / Ordering Example

1 Piezas / pcs. / pcs. SER 0808 E11



www.akkocom.tr

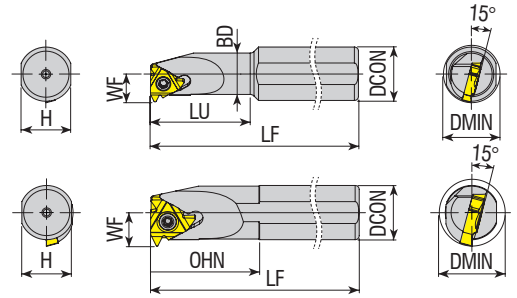
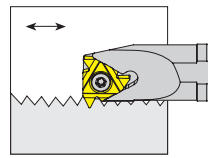

Código del Inserto Le Code de Commande Ordering Code	Stock Stock		Dimension (mm) Dimension (mm)					Inserto Plaquette Insert	Recambios / Pièces de Rechange / Spare Parts						
	R	L	DCON	BD	LF	LU=OHN	WF		DMIN	Tornillo Vis Screw	Cuñas Assise Shim	Tornillo de Placa Vis a Assise Shim Screw	Abrazadera de Cuñas Mode de Fixation Wedge Clamp	Tornillo de Sujeción Vis de Fixation Wedge Screw	Llave Torx Clé Torx Torx Wrench
SIR/L S12X05H 06	●	○	12	05	100	15	4.3	6.4	06 IR/L	3006-M2X3.6	-	-	-	-	80-T06
SIR/L S16X05H 06	○	●	16	05	100	15	4.3	6.4							
SIR/L S16X07M 08	●	●	16	07	150	18	5.3	7.8	08 IR/L	3007-M2.2x5	-	-	-	-	80-T07
SIR/L S10H 11	●	●	10	10	100	-	7.4	12	11 IR/L	4008-M2.5x6	-	-	-	-	80-T08
SIR/L S12K 11	●	●	12	12	125	-	8.4	16							
SIR/L S16X10M 11	●	●	16	10	150	25	7.4	12							
SIR/L S16X13M 11	●	●	16	13	150	32	8.9	15							
SIR/L S16M 11	●	●	16	16	150	-	11.7	19							
SIR/L S16X13M 16	●	●	16	13	150	32	10.2	16							
SIR/L S16M 16	●	●	16	16	150	-	11.7	19	16 IR/L (0.35 - 3) ISO METRIC	4015-M3.5x11	-	-	-	-	80-T15
SIR/L S20X16P 16	●	●	20	16	170	40	11.7	19							
SIR/L S20P 16	●	●	20	20	170	-	13.7	24							
SIR/L S25R 16C	●	●	25	25	200	-	16.2	29							
SIR/L S32S 16C	●	●	32	32	250	-	19.7	36							
SIR/L S40T 16C	●	●	40	40	300	-	23.7	44							
SIR/L S50U 16C	●	●	50	50	350	-	28.7	54	22 IR/L (3.5 - 4.5) ISO METRIC	1020-M4.5x16	AATN-2-0004	AAV-07-M4.5x13	ACK-05	4015-M4x11	80-T20
SIR/L S20P 22	●	●	20	20	170	-	15.7	24							
SIR/L S25R 22C	●	●	25	25	200	-	18.1	29							
SIR/L S32S 22C	●	●	32	32	250	-	21.6	38							
SIR/L S40T 22C	●	●	40	40	300	-	25.6	46							
SIR/L S50U 22C	●	●	50	50	350	-	30.6	58							
SIR/L S25R 16C-T	●	●	25	25	200	-	16.2	29	16 IR/L (1.5-3 TR)	4015-M3.5x14	-	-	-	-	80-T15
SIR/L S32S 16C-T	●	●	32	32	250	-	19.7	36	22 IR/L (4-6 TR)	1020-M4.5x16	-	-	-	-	80-T20
SIR/L S25R 22C-T	●	●	25	25	200	-	18.1	29							
SIR/L S32S 22C-T	●	●	32	32	250	-	21.6	38							

R: Derecha / Droite / Right L: Izquierda / Gauche / Left
 ● En Existencia / En stock / In Stock ○ Artículo sin Existencia / Indisponible en Stock / Non Stock Item
 ADVERTENCIA / ATTENTION / WARNING: P130: La operación para B y D en la página 130 no se puede aplicar. / L'opération B et D à la page 130 ne peut pas être appliquée. / The operation for B and D on page 130 can not be applied.
 Ejemplo de Pedido / Exemple de Commande / Ordering Example
 1 Piezas / pcs. / pcs. SIR S12X05H 06

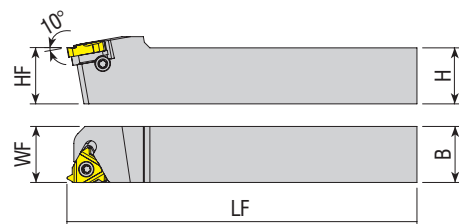
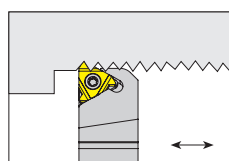

Código del Inserto Le Code de Commande Ordering Code	Stock		Dimension (mm) Dimension (mm)				Inserto Plaquette Insert	Recambios / Pièces de Rechange / Spare Parts					
	R	L	HF=H	B	LF	WF		Tornillo Vis Screw	Cuña Derecha Assise Droite Right Shim	Cuña Izquierda Assise Gauche Left Shim	Tornillo de Placa Vis a Assise Shim Screw	Anillo de Tornillo de Cuña Assise Bague à Vis Shim Screw Ring	Llave Torx Clé Torx Torx Wrench
TER/L 1616 H16	●	●	16	16	100	16	16 ER/EL	1710-U5-40x12.2	ATS-16E	ATS-16I	AAV-11-U5-40x4.5	ABPL-03	80-T10
TER/L 2020 K16	●	●	20	20	125	20							
TER/L 2525 M16	●	●	25	25	150	25							
TER/L 3232 P16	●	●	32	32	170	32	22 ER/EL	1720-U8-32x15	ATS-22E	ATS-22I	AAV-12-U8-32x5.5	ABPL-04	80-T20
TER/L 2525 M22	●	●	25	25	150	25							
TER/L 3232 P22	●	●	32	32	170	32							
TER/L 4040 S22	●	●	40	40	250	40	27 ER/EL	1620-M5x22	ATS-27E	ATS-27I	AAV-15-M5x5.7	ABPL-05	80-T20
TER/L 2525 M27	●	●	25	25	150	25							
TER/L 3232 P27	●	●	32	32	170	32							
TER/L 4040 S27	●	●	40	40	250	40							

R: Derecha / Droite / Right L: Izquierda / Gauche / Left
 ● En Existencia / En stock / In Stock ○ Artículo sin Existencia / Indisponible en Stock / Non Stock Item
 Las herramientas tienen un ángulo de hélice de 1.5° incorporado. / Les outils ont un construit en angle d'hélice de 1,5°. / The tools have a built in 1.5° helix angle.

Ejemplo de Pedido / Exemple de Commande / Ordering Example
 1 Piezas / pcs. / pcs. TER 1616 H16

OPERACIÓN DE ROSCADO EXTERNO DERECHO
EXTÉRIEUR DROITE FONCTIONNEMENT THREADING
EXTERNAL RIGHT HAND THREADING OPERATION

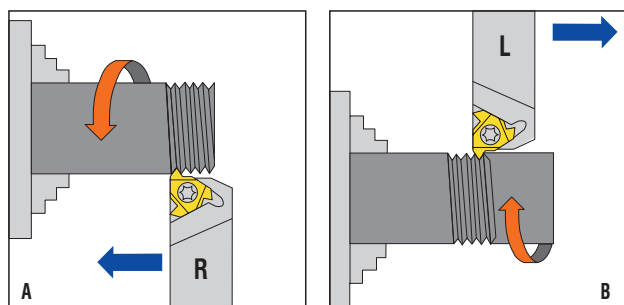

OPERACIÓN DE ROSCADO INTERNO IZQUIERDO
EXTÉRIEUR GAUCHE FONCTIONNEMENT THREADING
EXTERNAL LEFT HAND THREADING OPERATION

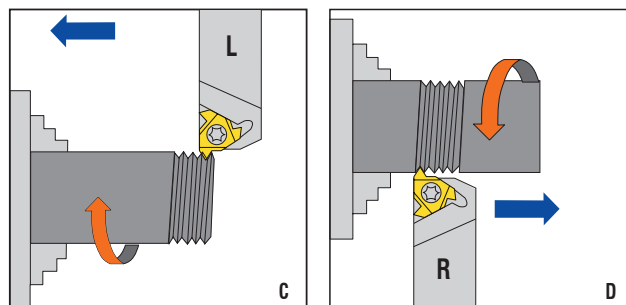

ADVERTENCIA / ATTENTION / WARNING

Para las figuras B y D; se debe usar una Calce negativa. / Pour la figure B et D; cale négative doit être utilisée. / For figure B and D; negative shim must be used.
 Las figuras B y D no se pueden aplicar en herramientas sin Calce. / Les chiffres B et D ne peuvent pas être appliqués sur les outils sans cale. / B and D figures can not be applied on tools without shim.

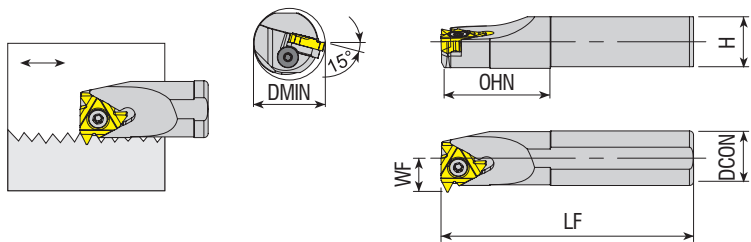

Código del Inserto Le Code de Commande Ordering Code	Stock		Dimension (mm) Dimension (mm)					Inserto Plaquette Insert	Recambios / Pièces de Rechange / Spare Parts						
	R	L	DCÓN	WF	LF	OHN	WF		DMIN	Tornillo Vis Screw	Cuña Derecha Assise Droite Right Shim	Cuña Izquierda Assise Gauche Left Shim	Tornillo de Placa Vis a Assise Shim Screw	Anillo de Tornillo de Cuña Assise Bague à Vis Shim Screw Ring	Llave Torx Clé Torx Torx Wrench
TIR/L S25R 16	●	●	25	25	200	-	16.2	29	16 IR/L	1710-U5-40x12.2	ATS-16E	ATS-16I	AAV-11-U5-40x4.5	ABPL-03	80-T10
TIR/L S32S 16	●	●	32	32	250	-	19.7	36							
TIR/L S40T 16	●	●	40	40	300	-	23.7	44							
TIR/L S50U 16	●	●	50	50	350	-	28.7	54							
TIR/L S25R 22	●	●	25	25	200	-	18.1	29	22 IR/L	1720-U8-32x15	ATS-22E	ATS-22I	AAV-12-U8-32x5.5	ABPL-04	80-T20
TIR/L S32S 22	●	●	32	32	250	-	21.6	38							
TIR/L S40T 22	●	●	40	40	300	-	25.6	46							
TIR/L S50U 22	●	●	50	50	350	-	30.6	58							
TIR/L S32S 27	●	●	32	32	250	-	22.6	40	27 IR/L	1620-M5x18	ATS-27E	ATS-27I	AAV-15-M5x5.7	ABPL-05	80-T20
TIR/L S40T 27	●	●	40	40	300	-	26.6	48		1620-M5x22					
TIR/L S50U 27	●	●	50	50	350	-	31.6	58							
TIR/L A25R 16	○	●	25	25	200	50	16.2	29	16 IR/L	1710-U5-40x12.2	ATS-16E	ATS-16I	AAV-11-U5-40x4.5	ABPL-03	80-T10
TIR/L A32S 16	○	●	32	32	250	60	19.7	36							
TIR/L A40T 16	○	●	40	40	300	65	23.9	44							

R: Derecha / Droite / Right L: Izquierda / Gauche / Left

● En Existencia / En stock / In Stock ○ Artículo sin Existencia / Indisponible en Stock / Non Stock Item

Las herramientas tienen un ángulo de hélice de 1.5° incorporado. / Les outils ont un construit en angle d'hélice de 1,5°. / The tools have a built in 1.5° helix angle.

Ejemplo de Pedido / Exemple de Commande / Ordering Example

1 Piezas / pcs. / pcs. TIR S25R 16

OPERACIÓN DE CORREA INTERNA DERECHA
DROIT Interieur MAIN OPERATION THREADING
INTERNAL RIGHT HAND THREADING OPERATION

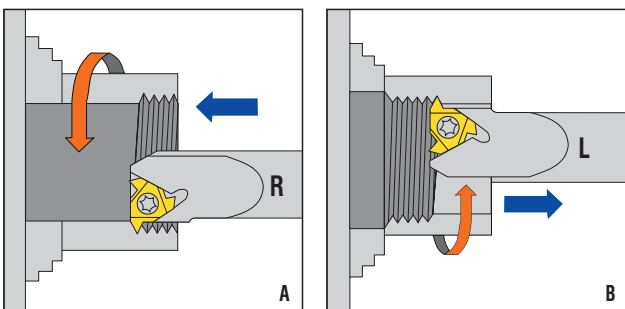

OPERACIÓN DE ROSCADO INTERNO IZQUIERDO
Interieur GAUCHE FONCTIONNEMENT THREADING
INTERNAL LEFT HAND THREADING OPERATION

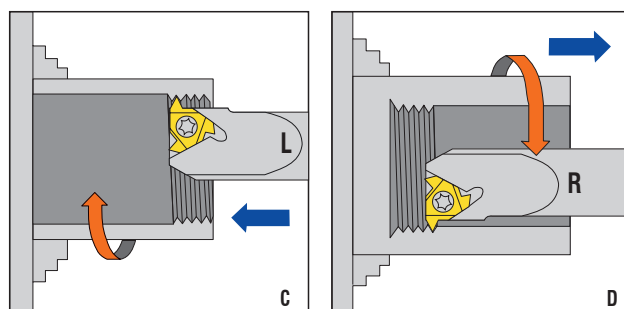

ADVERTENCIA / ATTENTION / WARNING

Para las figuras B y D; se debe usar una Calce negativa. / Pour la figure B et D; cale négative doit être utilisé. / For figure B and D; negative shim must be used.

Las figuras B y D no se pueden aplicar en herramientas sin Calce. / Les chiffres B et D ne peuvent pas être appliqués sur les outils sans cale. / B and D figures can not be applied on tools without shim.

Hilo de Ángulo de Hélice Enfilez Angle D'hélice Thread Helix Angle

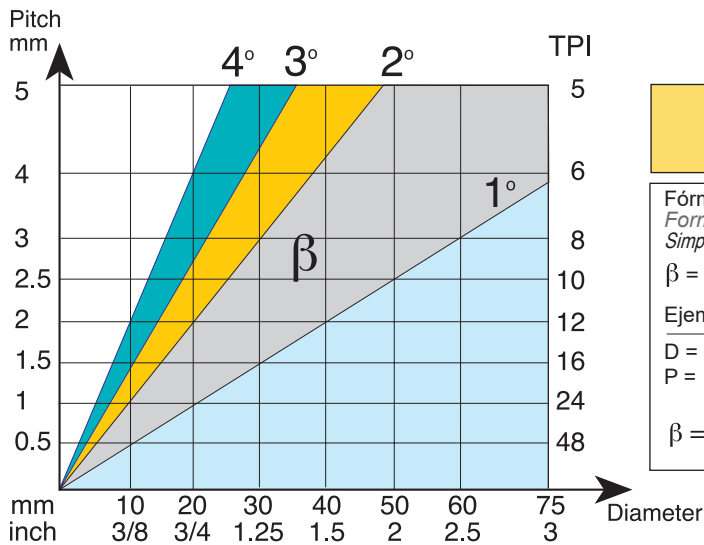

$$\tan \beta = \frac{P}{\pi \times D}$$

Fórmula Simplificada
 Formule Simplifiée
 Simplified Formula

$$\beta = 18.2 P/D$$

Ejemplo / Esempio / Example:

$$D = 25 \text{ mm (0.98")}$$

$$P = 1.5 \text{ mm (16 TPI)}$$

$$\beta = \frac{18.2 \times 1.5}{40} = 1.09^\circ$$

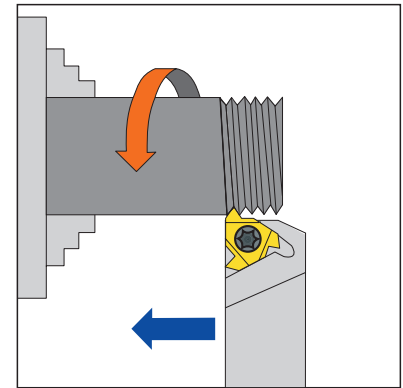

Calce Estándar e Inclinada Cale Standard Standard and Angular Shims

Los bolsillos para portaherramientas Akko tienen un ángulo de hélice de 1.5° incorporado. Este ángulo se puede ajustar para que coincida mejor con el ángulo de la hélice del hilo simplemente cambiando la Calce. La hélice negativa generalmente se usa al enhebrar el hilo derecho con el soporte izquierdo o el hilo izquierdo con el soporte derecho.

Les sièges des plaquettes des outils de filetage AKKO sont fabriqués avec un angle d'hélice de 1,5°. Si un filetage avec un angle d'hélice différent est souhaité, changer la cale peut aider à obtenir l'angle souhaité. Des cales à angle d'hélice négative sont utilisées lors du tournage de filetages à gauche avec des outils à droite.

Insert seats of Akko threading tools are produced with a 1.5° helix angle. If threading with a different helix angle is wanted, changing the shim can help with obtaining the wanted angle. Negative helix angled shims are used when turning left-hand threads with right-hand tools.

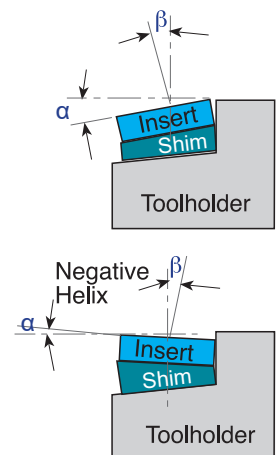

L	IC	Tipo de Herramienta Type D'outil Tool Type	Ángulo de Bolsillo (α) / Angle de Poche (α de) / Inserts Seat Angle (α)						
			4.5°	3.5°	2.5°	1.5°	0.5°	-0.5°	-1.5°
16	3/8	EX-RH or IN-LH	ATS-16E+4.5	ATS-16E+3.5	ATS-16E+2.5	ATS-16E	ATS-16E+0.5	ATS-16E-0.5	ATS-16E-1.5
16	3/8	EX-LH or IN-RH	ATS-16I+4.5	ATS-16I+3.5	ATS-16I+2.5	ATS-16I	ATS-16I+0.5	ATS-16I-0.5	ATS-16I-1.5
22	1/2	EX-RH or IN-LH	ATS-22E+4.5	ATS-22E+3.5	ATS-22E+2.5	ATS-22E	ATS-22E+0.5	ATS-22E-0.5	ATS-22E-1.5
22	1/2	EX-LH or IN-RH	ATS-22I+4.5	ATS-22I+3.5	ATS-22I+2.5	ATS-22I	ATS-22I+0.5	ATS-22I-0.5	ATS-22I-1.5
27	5/8	EX-RH or IN-LH	ATS-27E+4.5	ATS-27E+3.5	ATS-27E+2.5	ATS-27E	ATS-27E+0.5	ATS-27E-0.5	ATS-27E-1.5
27	5/8	EX-LH or IN-RH	ATS-27I+4.5	ATS-27I+3.5	ATS-27I+2.5	ATS-27I	ATS-27I+0.5	ATS-27I-0.5	ATS-27I-1.5

Recomendación de Cambio de Calce / Recommendation Pour le Changement de Cale

Shim Change Recommendation Table

Como se puede ver en la tabla, algunas combinaciones de Paso a Diámetro requieren un cambio de Cuña. Si se requiere un cambio, use una Cuña ATS-E para portaherramientas EX-RH e IN-LH y Cuñas ATS-I para portaherramientas IN-RH y EX-LH.
 Selon le tableau, les combinaisons de pas à diamètre peuvent nécessiter un changement de cale, lorsqu'un changement de cale est nécessaire, utilisez des cales ATS-E pour les outils EX-RH et IN-LH, et des cales ATS-I pour IN-RH et EX-LH outils.
 Based on the chart, Pitch to Diameter combinations can require a change of shim, when shim change is required, use ATS-E shims for EX-RH and IN-LH tools, and ATS-I shims for IN-RH and EX-LH tools.

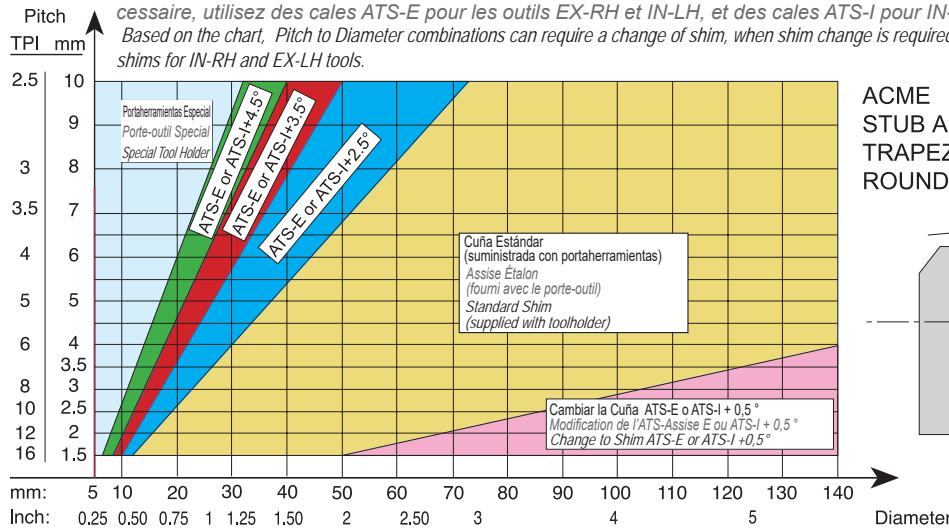

ACME
 STUB ACME
 TRAPEZ (DIN 103)
 ROUND (DIN 405)

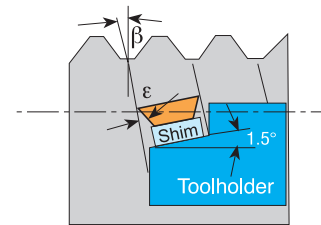

Como se puede ver en el cuadro, la mayoría de las aplicaciones no requieren un cambio de cuña. Si se requiere un cambio, use Cuñas ATS-E para portaherramientas EX-RH e IN-LH y Cuñas ATS-I para portaherramientas IN-RH y EX-LH.

D'après le graphe, la plupart des applications ne nécessitent pas de changement de cale. Si un changement de cale est nécessaire, utilisez des cales ATS-E pour les porte-outils EX-RH et IN-LH et des cales ATS-I pour les porte-outils IN-RH et EX-LH.

Based on the chart, most applications do not require a shim change. If shim change is required, use ATS-E shims for EX-RH and IN-LH tool holders and ATS-I shims for IN-RH and EX-LH tool holders.

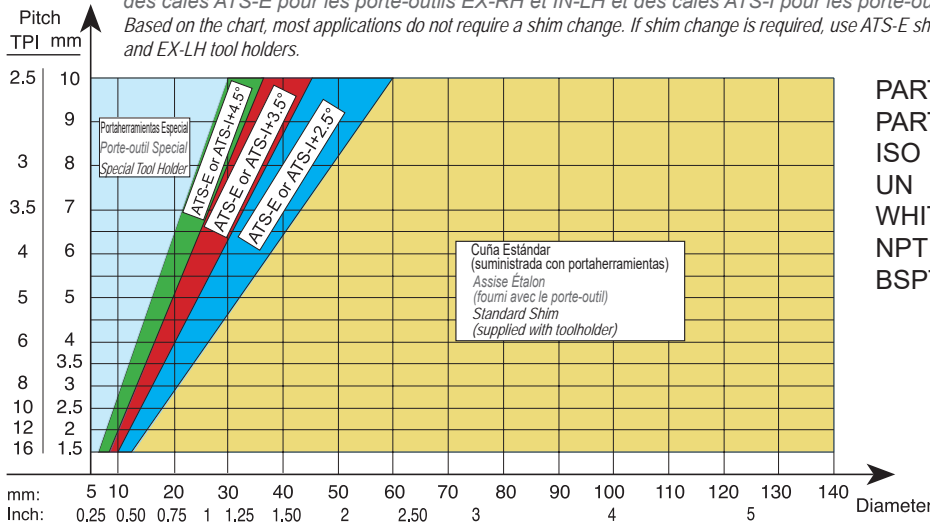

PARTIAL PROFILES 60°
 PARTIAL PROFILES 55°
 ISO
 UN
 WHIT.
 NPT
 BSPT

Como se puede ver en el cuadro, la mayoría de las aplicaciones requieren un cambio de Cuña. En la mayoría de los casos se requiere una Cuña negativa, use Cuñas ATS-E para portaherramientas EX-RH e IN-LH. Calzas ATS-I para portaherramientas IN-RH y EX-LH.

Comme on peut le voir sur le graphique, la plupart des applications nécessitent un changement de assise. Dans la plupart des cas une assise négative est nécessaire, utiliser des assises ATS-E pour EX-RH et IN-LH porte-outils. ATS-I assises pour IN-RH et EX-LH porte-outils.

Based on the chart, most applications require shim change. If shim change is required, use ATS-E shims for EX-RH and IN-LH tool holders and ATS-I shims for IN-RH and EX-LH tool holders.

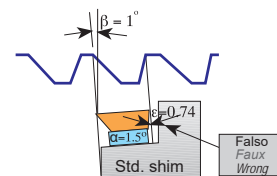
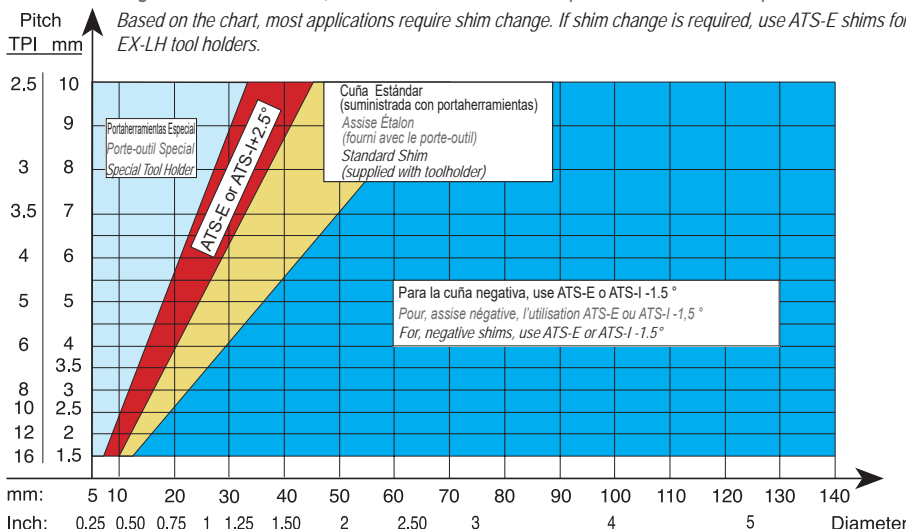

Antes de Cambiar la Cuñas
 Avant le Changement Assise
 Before Changing the Shim

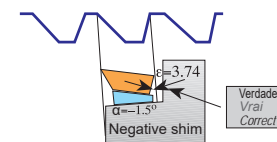

Después del Cambio de Cuñas
 Après le Changement Assise
 After Changing the Shim

AMERICAN
 BUTTRESS
 SAGENGWINDE
 (DIN 513)

Reemplazar el cuñas estándar con una cuñas que tiene ángulo negativo, eliminará el roce lateral.

Le remplacement de la assise standard par une assise à angle négatif éliminera le frottement latéral.

Replacing the standard shim with a shim has negative angle, will eliminate side rubbing.



konusulan
the spoken kalite...
quality...

GROOVING

HERRAMIENTAS DE ROSCADO
PORTE-OUTILS DE RAINURAGE
GROOVING TOOLHOLDERS





AKKO **A** **AKT** - **K** - **R** - **2525**

100 - 150 - **4** - **T22**

2 Estilo de Corte / Type D'outil / Cutter Style

DKT: Portaherramientas de Ranurado Externo / Exterieur Rainurage Porte-outils
External Grooving Tool holders
 IKT: Portaherramientas de Ranurado Interno / Rainurage Interieur Porte-outils
Internal Grooving Tool holders
 AKT: Portaherramientas de Ranurado Frontal / Visage Rainurage Porte-outils
Face Grooving Tool holders
 LKT: Portaherramientas de Ranurado Frontal Tipo L / L Type de Visage Rainurage Porte-outils
L Type Face Grooving Tool holders

3 Tipo de Inserto / Forme de Plaquette / Insert Type

KRLY / MGM. HRN / S312, S229, S224, S223 ISCR / DGN, GI, GTN SNDVK / 123, 151, 154.91 ZCC KM / A4. ARN / LOMR.	TGTC / TD.
--	------------

4 Dirección de Corte / Sens de Coupe
 Cutting Direction

R **L**

5 Altura de Borde de Corte y Ancho de Vástago
 Bord de Coupe Hauteur et Largeur Shank
 Cutting Edge Height and Shank Width

H
B
DCON

6 Rango del Corte
 Intervale de Coupe
 Cutting Range

DAXX (150)
DAXIN (100)

7 Ancho de Corte del Borde / Largeur de Coupe Bord
 Cutting Width Edge

E.G.:

- 2 = 2.0 mm
- 3 = 3.0 mm
- 4 = 4.0 mm
- 5 = 5.0 mm
- 6 = 6.0 mm
- 8 = 8.0 mm

CW

8 Profundidad de Corte / Profondeur de Coupe / Cutting Depth

CDX

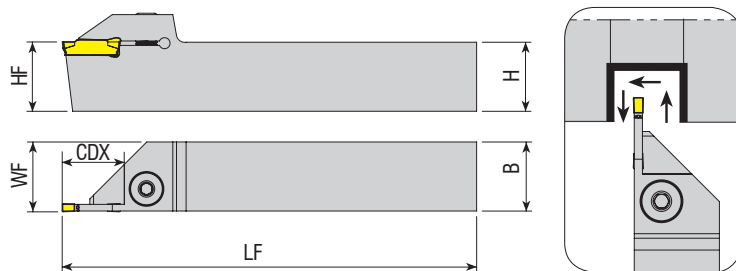

Código del Inserto Le Code de Commande Ordering Code	Stock Stock Stock		Dimension (mm) Dimension (mm) Dimension (mm)					Inserto Plaquette Insert	Recambios / Pièces de Rechange / Spare Parts		
	R	L	HF=H	B	LF	WF	CDX		Tornillo Vis Screw	Arandela Timbre Washer	Llaves Allen Clés Allen Allen Wrench
ADKT-K-R/L-1212-1.5-T15	●	●	12	12	100	12.2	15	MGM. - 1.5	AKV-02-M6x22	ABPL-01	AAL-03-3
ADKT-K-R/L-2020-1.5-T15	●	●	20	20	125	20.2	15				
ADKT-K-R/L-1212-2-T15	●	●	12	12	100	16.3	15				
ADKT-K-R/L-1616-2-T10	●	●	16	16	125	16.3	10	MGM. - 2	AKV-02-M6x22	ABPL-01	AAL-03-3
ADKT-K-R/L-1616-2-T15	●	●	16	16	125	16.3	15				
ADKT-K-R/L-2020-2-T15	●	●	20	20	150	20.3	15				
ADKT-K-R/L-2525-2-T15	●	●	25	25	150	25.3	15				
ADKT-K-R/L-3232-2-T15	●	●	32	32	170	32.3	15				
ADKT-K-R/L-1212-3-T15	●	●	12	12	100	12.3	15				
ADKT-K-R/L-1616-3-T15	●	●	16	16	125	16.3	15				
ADKT-K-R/L-2020-3-T10	●	●	20	20	125	20.3	10				
ADKT-K-R/L-2020-3-T20	●	●	20	20	125	20.3	20				
ADKT-K-R/L-2020-3-R28	●	●	20	20	125	20.3	28				
ADKT-K-R/L-2525-3-T10	●	●	25	25	150	25.3	10				
ADKT-K-R/L-2525-3-R15	●	●	25	25	150	25.3	15				
ADKT-K-R/L-2525-3-T22	●	●	25	25	150	25.3	22				
ADKT-K-R/L-3232-3-T10	●	●	32	32	170	32.3	10				
ADKT-K-R/L-3232-3-T22	●	●	32	32	170	32.3	22				
ADKT-K-R/L-2020-4-T10	●	●	20	20	125	20.4	10	MGM. - 4	2004-M8x1x20	-	AAL-05-4
ADKT-K-R/L-2020-4-T20	●	●	20	20	125	20.4	20				
ADKT-K-R/L-2020-4-R25	●	○	20	20	125	20.4	25				
ADKT-K-R/L-2525-4-T10	●	●	25	25	150	25.4	10				
ADKT-K-R/L-2525-4-T18	●	●	25	25	150	25.4	18				
ADKT-K-R/L-2525-4-T22	●	●	25	25	150	25.4	22				
ADKT-K-R/L-3232-4-T10	●	●	32	32	170	32.4	10				
ADKT-K-R/L-3232-4-T22	●	●	32	32	170	32.4	22				
ADKT-K-R/L-2020-5-T20	●	●	20	20	125	20.5	20	MGM. - 5			
ADKT-K-R/L-2525-5-T15	●	●	25	25	150	25.5	15				
ADKT-K-R/L-2525-5-T18	●	●	25	25	150	25.5	18				
ADKT-K-R/L-2525-5-T25	●	●	25	25	150	25.5	25				
ADKT-K-R/L-3232-5-T15	●	●	32	32	170	32.5	15				
ADKT-K-R/L-3232-5-T25	●	●	32	32	170	32.5	25	MGM. - 6			
ADKT-K-R/L-2525-6-T15	●	●	25	25	150	25.6	15				
ADKT-K-R/L-2525-6-T25	●	●	25	25	150	25.6	25				
ADKT-K-R/L-3232-6-T25	●	●	32	32	170	32.6	25	MGM. - 8			
ADKT-K-R/L-3232-8-T32	●	●	32	32	170	32.8	32				

R: Derecha / Droite / Right L: Izquierda / Gauche / Left

● En Existencia / En stock / In Stock ○ Artículo sin Existencia / Indisponible en Stock / Non Stock Item

Compatible con el Inserto KRLY - JD. / Compatible avec KRLY - JD Plaquettes. / Compatible with KRLY - JD Insert.

Ejemplo de Pedido / Exemple de Commande / Ordering Example

1 Piezas / pcs. / pcs. ADKT-K-R-1212-1.5-T15

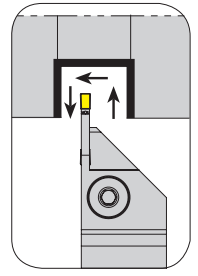
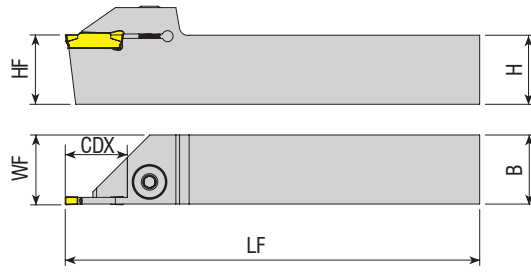
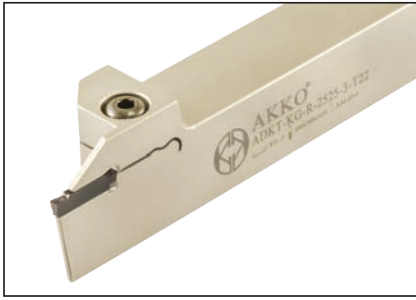

Código del Inserto
 Le Code de Commande
 Ordering Code

Código del Inserto Le Code de Commande Ordering Code	Stock Stock Stock		Dimension (mm) Dimension (mm) Dimension (mm)				Inserto Plaquette Insert	Recambios / Pièces de Rechange / Spare Parts			
	R	L	HF=H	B	LF	WF		CDX	Tornillo Vis Screw	Arandela Tembre Washer	Llaves Allen Clés Allen Allen Wrench
ADKT-KG-R/L-2020-2-T15	●	●	20	20	125	20.2	15	KG.. - 2	AKV-02-M6x22	ABPL-01	AAL-03-3
ADKT-KG-R/L-2525-2-T8	●	●	25	25	150	25.2	8				
ADKT-KG-R/L-2525-2-T15	●	○	25	25	150	25.2	15				
ADKT-KG-R/L-2525-2-T17	●	○	25	25	150	25.2	17	KG.. - 3			
ADKT-KG-R/L-1616-3-T20	●	●	16	16	125	16.3	20				
ADKT-KG-R/L-2020-3-T20	●	●	20	20	125	20.3	20				
ADKT-KG-R/L-2525-3-T10	●	●	25	25	150	25.3	10				
ADKT-KG-R/L-2525-3-T13	●	●	25	25	150	25.3	13				
ADKT-KG-R/L-2525-3-T22	●	●	25	25	150	25.3	22				
ADKT-KG-R/L-2020-4-T20	●	●	20	20	125	20.4	20	KG.. - 4	2004-M8x1x20	-	AAL-05-4
ADKT-KG-R/L-2525-4-T10	●	●	25	25	150	25.4	10				
ADKT-KG-R/L-2525-4-T16	●	○	25	25	150	25.4	16				
ADKT-KG-R/L-2525-4-T22	●	○	25	25	150	25.4	22				
ADKT-KG-R/L-2525-5-T12	●	●	25	25	150	25.5	12	KG.. - 5			
ADKT-KG-R/L-2525-5-T15	●	●	25	25	150	25.5	15				
ADKT-KG-R/L-2525-5-T25	●	○	25	25	150	25.5	25	KG.. - 6			
ADKT-KG-R/L-2525-6-T25	○	○	25	25	150	25.6	25				

R: Derecha / Droite / Right L: Izquierda / Gauche / Left

● En Existencia / En stock / In Stock ○ Artículo sin Existencia / Indisponible en Stock / Non Stock Item
 Compatible con el Inserto KRLY. / Compatible avec KRLY Plaquettes. / Compatible with KRLY Insert.

Ejemplo de Pedido / Exemple de Commande / Ordering Example

1 Piezas / pcs. / pcs. ADKT-KG-R-2020-2-T15



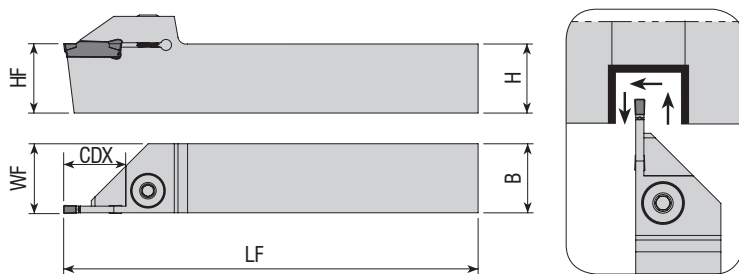

Código del Inserto Le Code de Commande Ordering Code	Stock Stock		Dimension (mm) Dimension (mm) Dimension (mm)				Inserto Plaquette Insert	Recambios / Pièces de Rechange / Spare Parts			
	R	L	HF=H	B	LF	WF		CDX	Tornillo Vis Screw	Arandela Timbre Washer	Llaves Allen Clés Allen Allen Wrench
ADKT-SGC-R/L-1212-2-R15	●	●	12	12	100	16.2	15	GCM N20	AKV-02-M6x22	ABPL-01	AAL-03-3
ADKT-SGC-R/L-1616-2-R15	●	●	16	16	125	16.2	15				
ADKT-SGC-R/L-2020-2-R20	●	●	20	20	125	20.2	20				
ADKT-SGC-R/L-2525-2-R20	●	●	25	25	150	25.2	20				
ADKT-SGC-R/L-1212-3-R15	●	●	12	12	100	16.3	15	GCM N30	2004-M8x1x20	-	AAL-05-4
ADKT-SGC-R/L-1616-3-R15	●	●	16	16	125	16.3	15				
ADKT-SGC-R/L-2020-3-R22	●	●	20	20	125	20.3	22				
ADKT-SGC-R/L-2525-3-R15	●	○	25	25	150	25.3	15				
ADKT-SGC-R/L-2525-3-R22	●	●	25	25	150	25.3	22	GCM N40			
ADKT-SGC-R/L-2525-4-R25	●	○	25	25	150	25.4	25				

Compatible con el Inserto SMTM. / Compatible avec SMTM Plaquettes. / Compatible with SMTM Insert.

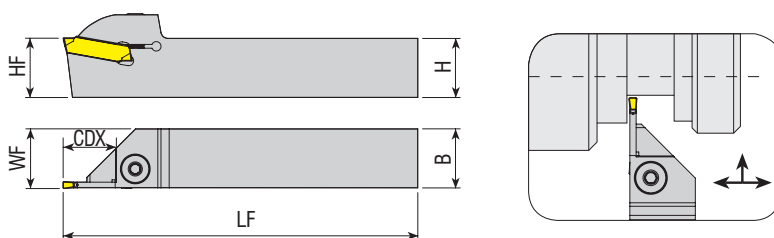

Código del Inserto Le Code de Commande Ordering Code	Stock Stock		Dimension (mm) Dimension (mm) Dimension (mm)				Inserto Plaquette Insert	Recambios / Pièces de Rechange / Spare Parts			
	R	L	HF=H	B	LF	WF		CDX	Tornillo Vis Screw	Arandela Timbre Washer	Llaves Allen Clés Allen Allen Wrench
ADKT-H-R/L-2020-3-T20	●	●	20	20	125	20.5	20	S229 - 3			
ADKT-H-R/L-2525-3-T22	●	●	25	25	150	25.5	22				
ADKT-H-R/L-2525-3-T26	●	●	25	25	150	25.5	26				
ADKT-H-R/L-2020-4-T20	●	●	20	20	125	20.5	20	S229 - 4	2004-M8x1x20	-	AAL-05-4
ADKT-H-R/L-2525-4-T22	●	●	25	25	150	25.5	22				
ADKT-H-R/L-3232-4-T22	●	●	32	32	170	32.5	22				
ADKT-H-R/L-2020-5-T20	●	●	20	20	125	20.5	20				
ADKT-H-R/L-2525-5-T25	●	●	25	25	150	25.5	25	S229 - 5			
ADKT-H-R/L-2525-6-T25	●	●	25	25	150	25.6	25				

R: Derecha / Droite / Right L: Izquierda / Gauche / Left

● En Existencia / En stock / In Stock ○ Artículo sin Existencia / Indisponible en Stock / Non Stock Item
 Compatible con el Inserto HRN. / Compatible avec HRN Plaquettes. / Compatible with HRN Insert.

Ejemplo de Pedido / Exemple de Commande / Ordering Example

1 Piezas / pcs. / pcs. ADKT-SGC-R-1212-2-R15

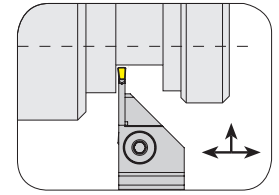
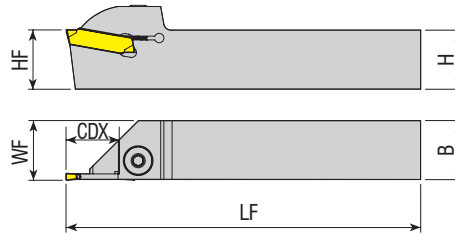

Código del Inserto Le Code de Commande Ordering Code	Stock Stock Stock		Dimension (mm) Dimension (mm) Dimension (mm)				Inserto Plaquette Insert	Recambios / Pièces de Rechange / Spare Parts			
	R	L	HF=H	B	LF	WF		CDX	Tornillo Vis Screw	Arandela Timbre Washer	Llaves Allen Clés Allen Allen Wrench
ADKT-HK-R/L-1616-2-T15	●	●	16	16	125	16.3	15	S224 - 2	AKV-02-M6x22	ABPL-01	AAL-03-3
ADKT-HK-R/L-2020-2-T15	●	●	20	20	125	20.3	15				
ADKT-HK-R/L-2525-2-T15	●	●	25	25	150	25.3	15				
ADKT-HK-R/L-1616-3-T15	○	○	16	16	125	16.3	15	S224 - 3	2004-M8x1x20	-	AAL-05-4
ADKT-HK-R/L-2020-3-T20	●	●	20	20	125	20.4	20				
ADKT-HK-R/L-2525-3-T22	●	●	25	25	150	25.4	22				
ADKT-HK-R/L-2020-4-T20	●	●	20	20	125	20.4	20				
ADKT-HK-R/L-2525-4-T22	●	●	25	25	150	25.4	22	S224 - 4			
ADKT-HS223-R/L-2020-2-T15	●	○	20	20	125	20.4	15				
ADKT-HS223-R/L-2020-3-T17	●	○	20	20	125	20.3	17	S223 - 3	2004-M8x1x20	-	AAL-05-4

Compatible con el Inserto HRN. / Compatible avec HRN Plaquettes. / Compatible with HRN Insert.

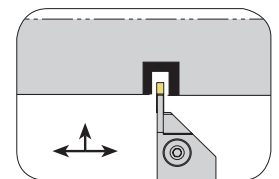
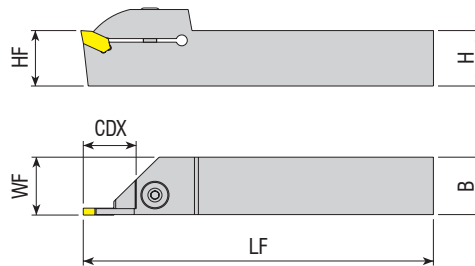

Código del Inserto Le Code de Commande Ordering Code	Stock Stock Stock		Dimension (mm) Dimension (mm) Dimension (mm)				Inserto Plaquette Insert	Recambios / Pièces de Rechange / Spare Parts			
	R	L	HF=H	B	LF	WF		CDX	Tornillo Vis Screw	Arandela Timbre Washer	Llaves Allen Clés Allen Allen Wrench
ADKT-ZCC1-R/L-2020-3-T20	●	○	20	20	125	20.3	20	ZQMX - 3	2004-M8x1x20	-	AAL-05-4
ADKT-ZCC1-R/L-2525-3-T22	●	○	25	25	150	25.3	22				
ADKT-ZCC1-R/L-2020-4-T20	●	○	20	20	125	20.4	20	ZQMX - 4			
ADKT-ZCC1-R/L-2525-4-T22	●	○	25	25	150	25.4	22				

R: Derecha / Droite / Right L: Izquierda / Gauche / Left

● En Existencia / En stock / In Stock ○ Artículo sin Existencia / Indisponible en Stock / Non Stock Item

Compatible con el Inserto ZCC. / Compatible avec ZCC Plaquettes. / Compatible with ZCC Insert.

Ejemplo de Pedido / Exemple de Commande / Ordering Example

1 Piezas / pcs. / pcs. ADKT-HK-R-1616-2-T15

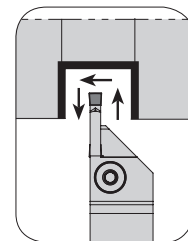
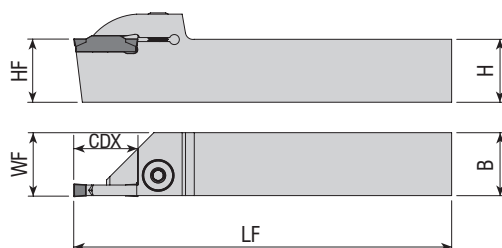

Código del Inserto Le Code de Commande Ordering Code	Stock Stock		Dimension (mm) Dimension (mm) Dimension (mm)					Inserto Plaquette Insert	Recambios / Pièces de Rechange / Spare Parts		
	R	L	HF=H	B	LF	WF	CDX		Tornillo Vis Screw	Arandela Timbre Washer	Llaves Allen Clés Allen Allen Wrench
ADKT-ZCC2-R/L-1616-2-T15	●	●	16	16	125	16.2	15	Z.BD - 2	AKV-02-M6x22	ABPL-01	AAL-03-3
ADKT-ZCC2-R/L-2020-2-T7	●	●	20	20	125	20.2	7				
ADKT-ZCC2-R/L-2020-2-T15	●	●	20	20	125	20.2	15				
ADKT-ZCC2-R/L-2525-2-T15	●	●	25	25	150	25.2	15	Z.ED - 2.5			
ADKT-ZCC2-R/L-1616-2.5-T15	●	●	16	16	125	16.3	15				
ADKT-ZCC2-R/L-2020-2.5-T17	●	●	20	20	125	20.3	17				
ADKT-ZCC2-R/L-2525-2.5-T15	●	●	25	25	150	25.3	15	Z.FD - 3			
ADKT-ZCC2-R/L-1616-3-T15	●	●	16	16	125	16.3	15				
ADKT-ZCC2-R/L-1616-3-T17	●	○	16	16	125	16.3	17				
ADKT-ZCC2-R/L-1616-3-T20	●	○	16	16	125	16.3	20	Z.GD - 4	2004-M8x1x20	-	AAL-05-4
ADKT-ZCC2-R/L-2020-3-T12	●	●	20	20	125	20.3	12				
ADKT-ZCC2-R/L-2020-3-T20	●	●	20	20	125	20.3	20				
ADKT-ZCC2-R/L-2020-3-R21	●	○	20	20	125	20.3	21	Z.HD - 5			
ADKT-ZCC2-R/L-2020-3-R25	●	●	20	20	125	20.3	25				
ADKT-ZCC2-R/L-2525-3-T12	●	○	25	25	150	25.3	12				
ADKT-ZCC2-R/L-2525-3-T22	●	●	25	25	150	25.3	22	Z.KD - 6			
ADKT-ZCC2-R/L-2525-3-R30	●	●	25	25	150	25.3	30				
ADKT-ZCC2-R/L-2020-4-T12	●	○	20	20	125	20.5	12				
ADKT-ZCC2-R/L-2020-4-T20	●	●	20	20	125	20.5	20	Z.HD - 5			
ADKT-ZCC2-R/L-2525-4-T12	●	●	25	25	150	25.5	12				
ADKT-ZCC2-R/L-2525-4-T22	●	●	25	25	150	25.5	22				
ADKT-ZCC2-R/L-2020-5-T12	●	○	20	20	125	20.5	12	Z.KD - 6			
ADKT-ZCC2-R/L-2020-5-T20	●	●	20	20	125	20.5	20				
ADKT-ZCC2-R/L-2525-5-T12	●	○	25	25	150	25.5	12				
ADKT-ZCC2-R/L-2525-5-T25	●	●	25	25	150	25.5	25	Z.KD - 6			
ADKT-ZCC2-R/L-3232-5-T25	●	●	32	32	170	32.5	25				
ADKT-ZCC2-R/L-2020-6-T20	●	●	20	20	125	20.6	20				
ADKT-ZCC2-R/L-2525-6-T25	●	●	25	25	150	25.6	25	Z.KD - 6			
ADKT-ZCC2-R/L-3232-6-T25	●	●	32	32	170	32.6	25				
ADKT-ZCC2-R/L-3232-6-T30	●	●	32	32	170	32.6	30				

R: Derecha / Droite / Right L: Izquierda / Gauche / Left

● En Existencia / En stock / In Stock ○ Artículo sin Existencia / Indisponible en Stock / Non Stock Item
 Compatible con el Inserto ZCC. / Compatible avec ZCC Plaquettes. / Compatible with ZCC Insert.

Ejemplo de Pedido / Exemple de Commande / Ordering Example

1 Piezas / pcs. / pcs. ADKT-ZCC2-R-1616-2-T15

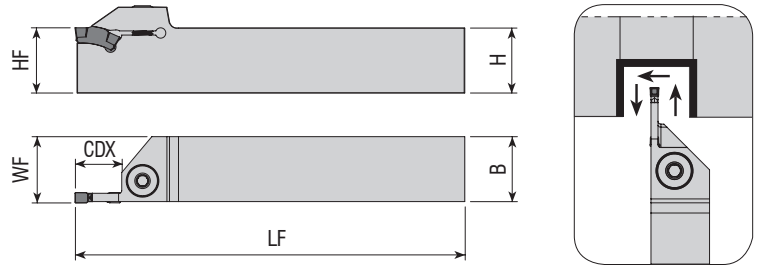

Código del Inserto Le Code de Commande Ordering Code	Stock Stock		Dimension (mm) Dimension (mm)				Inserto Plaquette Insert	Recambios / Pièces de Rechange / Spare Parts				
	R	L	HF=H	B	LF	WF		CDX	Tornillo Vis Screw	Arandela Timbre Washer	Llaves Allen Clés Allen Allen Wrench	
ADKT-ITG-R/L-2020-3-T8	●	●	20	20	125	20.3	8	TGM. - 3	2004-M8x1x20	-	AAL-05-4	
ADKT-ITG-R/L-2525-3-T8	●	●	25	25	150	25.3	8					
ADKT-ITG-R/L-3232-3-T8	●	○	32	32	170	32.3	8					
ADKT-ITG-R/L-2020-4-T9	●	●	20	20	125	20.4	9					TGM. - 4
ADKT-ITG-R/L-2525-4-T17	●	●	25	25	150	25.4	17					
ADKT-ITG-R/L-3232-4-T17	●	●	32	32	170	32.4	17					
ADKT-ITG-R/L-3232-5-T25	●	○	32	32	170	32.5	25	TGM. - 5				

Compatible con el Inserto ISCR. / Compatible avec ISCR Plaquettes. / Compatible with ISCR Insert.

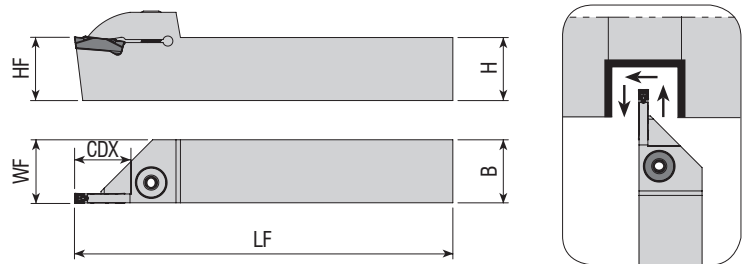

Código del Inserto Le Code de Commande Ordering Code	Stock Stock		Dimension (mm) Dimension (mm)				Inserto Plaquette Insert	Recambios / Pièces de Rechange / Spare Parts			
	R	L	HF=H	B	LF	WF		CDX	Tornillo Vis Screw	Arandela Timbre Washer	Llaves Allen Clés Allen Allen Wrench
ADKT-KM-R/L-2020-2-T15	●	●	20	20	125	20.3	15	A4. - 2	AKV-02-M6x22	ABPL-01	AAL-03-3
ADKT-KM-R/L-2525-2-T15	●	●	25	25	150	25.3	15				
ADKT-KM-R/L-2020-3-T20	●	●	20	20	125	20.4	20	A4. - 3	2004-M8x1x20	-	AAL-05-4
ADKT-KM-R/L-2525-3-T22	●	●	25	25	150	25.4	22				
ADKT-KM-R/L-2525-4-T22	●	●	25	25	150	25.5	22				

R: Derecha / Droite / Right L: Izquierda / Gauche / Left

● En Existencia / En stock / In Stock ○ Artículo sin Existencia / Indisponible en Stock / Non Stock Item

Compatible con el Inserto KNMTL. / Compatible avec KNMTL Plaquettes. / Compatible with KNMTL Insert.

Ejemplo de Pedido / Exemple de Commande / Ordering Example

1 Piezas / pcs. / pcs. ADKT-ITG-R-2020-3-T8

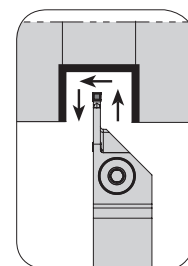
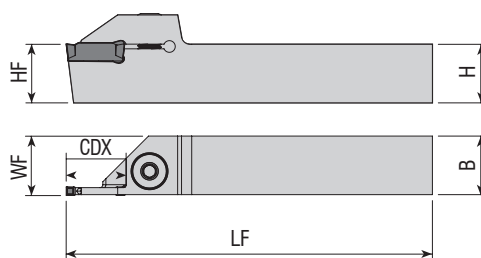

Código del Inserto Le Code de Commande Ordering Code	Stock Stock Stock		Dimension (mm) Dimension (mm) Dimension (mm)					Inserto Plaquette Insert	Recambios / Pièces de Rechange / Spare Parts		
	R	L	HF=H	B	LF	WF	CDX		Tornillo Vis Screw	Arandela Timbre Washer	Llaves Allen Clés Allen Allen Wrench
ADKT-I-R/L-1212-2-T15	●	●	12	12	125	16.3	15	DGN - 2	AKV-02-M6x22	ABPL-01	AAL-03-3
ADKT-I-R/L-1616-2-T15	●	●	16	16	100	16.3	15				
ADKT-I-R/L-2020-2-T15	●	●	20	20	125	20.3	15				
ADKT-I-R/L-2525-2-T15	●	●	25	25	150	25.3	15				
ADKT-I-R/L-3232-2-T15	●	●	32	32	170	32.3	15				
ADKT-I-R/L-1212-3-T15	●	●	12	12	100	16.3	15	DGN - 3			
ADKT-I-R/L-1616-3-T15	●	●	16	16	125	16.3	15				
ADKT-I-R/L-2020-3-T12	●	●	20	20	125	20.3	12				
ADKT-I-R/L-2020-3-T20	●	●	20	20	125	20.3	20				
ADKT-I-R/L-2525-3-T12	●	●	25	25	150	25.3	12				
ADKT-I-R/L-2525-3-T22	●	●	25	25	150	25.3	22	DGN / GRP - 4	2004-M8x1x20	-	AAL-05-4
ADKT-I-R/L-3232-3-T22	●	●	32	32	170	32.3	22				
ADKT-I-R/L-2020-4-T20	●	●	20	20	125	20.4	20				
ADKT-I-R/L-2525-4-T12	●	●	25	25	150	25.4	12				
ADKT-I-R/L-2525-4-T22	●	●	25	25	150	25.4	22				
ADKT-I-R/L-3232-4-T25	●	●	32	32	170	32.4	25	DGN / GRP - 5			
ADKT-I-R/L-2020-5-T20	●	●	20	20	125	20.5	20				
ADKT-I-R/L-2525-5-T12	●	●	25	25	150	25.5	12				
ADKT-I-R/L-2525-5-T25	●	●	25	25	150	25.5	25				
ADKT-IG-R/L-1616-3-T18	●	○	16	16	125	16.3	18				
ADKT-IG-R/L-2020-3-T12	●	●	20	20	125	20.3	12				
ADKT-IG-R/L-2020-3-R20	●	●	20	20	125	20.3	20				
ADKT-IG-R/L-2525-3-T12	●	●	25	25	150	25.3	12				
ADKT-IG-R/L-2525-3-T22	●	●	25	25	150	25.3	22				
ADKT-IGI-R/L-2020-2-T15	●	●	20	20	125	20.3	15	GIM / GIP - 2	AKV-02-M6x22	ABPL-01	AAL-03-3
ADKT-IGI-R/L-2525-2-T15	●	●	25	25	150	25.3	15				
ADKT-IGI-R/L-1616-3-T15	●	●	16	16	125	16.3	15	GIM / GIP - 3			
ADKT-IGI-R/L-2020-3-T20	●	●	20	20	125	20.3	20				
ADKT-IGI-R/L-2525-3-T9	●	●	25	25	150	25.3	9				
ADKT-IGI-R/L-2525-3-T22	●	●	25	25	150	25.3	22	GIM / GIP - 4	2004-M8x1x20	-	AAL-05-4
ADKT-IGI-R/L-2525-4-T22	●	●	25	25	150	25.4	22				
ADKT-IGI-R/L-2525-5-T25	●	●	25	25	150	25.5	25	GIM / GIP - 5			
ADKT-IGI-R/L-2525-8-T30	●	○	25	25	150	25.8	30	GIM / GIP - 8			
ADKT-IGTN-R/L-2525-5-T25	●	●	25	25	150	25.6	25	GTN - 5			
ADKT-IDC-R/L-2525-3-T21	●	○	25	25	150	25.4	21	DCE - 3			

R: Derecha / Droite / Right L: Izquierda / Gauche / Left

● En Existencia / En stock / In Stock ○ Artículo sin Existencia / Indisponible en Stock / Non Stock Item
 Compatible con el Inserto ISCR. / Compatible avec ISCR Plaquettes. / Compatible with ISCR Insert.

Ejemplo de Pedido / Exemple de Commande / Ordering Example

1 Piezas / pcs. / pcs. ADKT-I-R-1212-2-T15



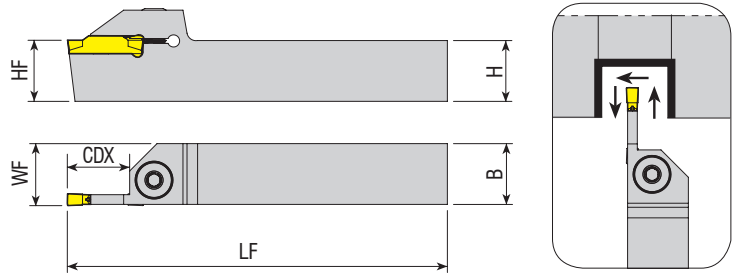

Código del Inserto Le Code de Commande Ordering Code	Stock		Dimension (mm) Dimension (mm)				Inserto Plaquette Insert	Recambios / Pièces de Rechange / Spare Parts			
	R	L	HF=H	B	LF	WF		CDX	Tornillo Vis Screw	Arandela Timbre Washer	Llaves Allen Clés Allen Allen Wrench
ADKT-123-R/L-1212-1.5-R15	●	●	12	12	100	12.2	15	123 - 1.5	AKV-02-M6x22	ABPL-01	AAL-03-3
ADKT-123-R/L-1616-1.5-R15	●	●	16	16	125	16.2	15				
ADKT-123-R/L-1616-2-T15	●	●	16	16	125	16.2	15				
ADKT-123-R/L-2020-2-T8	●	○	20	20	125	20.2	8				
ADKT-123-R/L-2020-2-T15	●	●	20	20	125	20.2	15				
ADKT-123-R/L-2525-2-T8	●	●	25	25	150	25.2	8				
ADKT-123-R/L-2525-2-T15	●	●	25	25	150	25.2	15				
ADKT-123-R/L-3232-2-T15	●	●	32	32	170	32.2	15				
ADKT-123-R-1616-3-T10	●	●	16	16	125	16.3	10	123 - 3	2004-M8x1x20	-	AAL-05-4
ADKT-123-R/L-1616-3-T15	●	●	16	16	125	16.3	15				
ADKT-123-R-2020-3-T10	●	●	20	20	125	20.3	10				
ADKT-123-R-2020-3-T15	●	●	20	20	125	20.3	15				
ADKT-123-R/L-2020-3-T20	●	●	20	20	125	20.3	20				
ADKT-123-R-2525-3-T10	●	●	25	25	150	25.3	10				
ADKT-123-R-2525-3-T15	●	●	25	25	150	25.3	15				
ADKT-123-R/L-2525-3-T22	●	●	25	25	150	25.3	22				
ADKT-123-R/L-2020-4-T20	●	●	20	20	125	20.4	20	123 - 4			
ADKT-123-R-2525-4-T13	●	●	25	25	150	25.4	13				
ADKT-123-R/L-2525-4-T22	●	●	25	25	150	25.4	22				
ADKT-123-R/L-3232-4-T25	●	●	32	32	170	32.4	25				
ADKT-123-R/L-2020-5-T20	●	●	20	20	125	20.5	20	123 - 5			
ADKT-123-R/L-2525-5-T25	●	●	25	25	150	25.5	25				
ADKT-123-R/L-3232-6-T15	●	●	32	32	170	32.5	15	123 - 6			

R: Derecha / Droite / Right L: Izquierda / Gauche / Left

● En Existencia / En stock / In Stock ○ Artículo sin Existencia / Indisponible en Stock / Non Stock Item

Compatible con el Inserto SNDVK. / Compatible avec SNDVK Plaquettes. / Compatible with SNDVK Insert.

Ejemplo de Pedido / Exemple de Commande / Ordering Example

1 Piezas / pcs. / pcs. ADKT-123-R-1212-1.5-R15

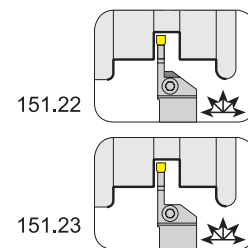
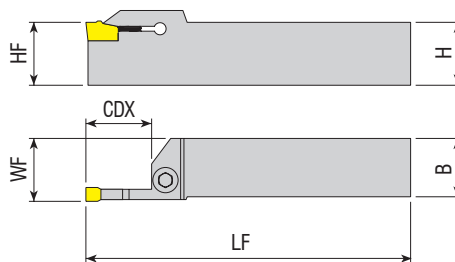

Código del Inserto Le Code de Commande Ordering Code	Stock Stock Stock		Dimension (mm) Dimension (mm) Dimension (mm)				Inserto Plaquette Insert	Recambios / Pièces de Rechange / Spare Parts			
	R	L	HF=H	B	LF	WF		CDX	Tornillo Vis Screw	Arandela Timbre Washer	Llaves Allen Clés Allen Allen Wrench
ADKT-151.22-R/L-1616-2-T15	●	●	16	16	125	16.3	15	151.2 - 2	AKV-02-M6x22	ABPL-01	AAL-03-3
ADKT-151.22-R/L-2020-2-T15	●	●	20	20	125	20.3	15				
ADKT-151.22-R/L-2525-2-T15	●	●	25	25	150	25.3	15				
ADKT-151.22-R/L-1616-3-T15	●	●	16	16	125	16.4	15	151.2 - 3	2004-M8x1x20	-	AAL-05-4
ADKT-151.22-R/L-2020-3-T20	●	●	20	20	125	20.4	20				
ADKT-151.22-R/L-2525-3-T22	●	●	25	25	150	25.4	22				
ADKT-151.22-R/L-1616-4-T15	●	●	16	16	125	16.4	15	151.2 - 4	2004-M8x1x20	-	AAL-05-4
ADKT-151.22-R/L-2020-4-T20	●	●	20	20	125	20.4	20				
ADKT-151.22-R/L-2525-4-T22	●	●	25	25	150	25.4	22				
ADKT-151.22-R/L-2020-5-T20	●	●	20	20	125	20.5	20	151.2 - 5	2004-M8x1x20	-	AAL-05-4
ADKT-151.22-R/L-2525-5-T25	●	●	25	25	150	25.5	25				
ADKT-151.23-R/L-1616-2-T15	●	●	16	16	125	16.3	15	151.2 - 2	AKV-02-M6x22	ABPL-01	AAL-03-3
ADKT-151.23-R/L-2020-2-T15	●	●	20	20	125	20.3	15				
ADKT-151.23-R/L-2525-2-T15	●	●	25	25	150	25.3	15				
ADKT-151.23-R/L-1616-2.5-T15	●	●	16	16	125	16.3	15	151.2 - 2.5	2004-M8x1x20	-	AAL-05-4
ADKT-151.23-R/L-2020-2.5-T15	●	●	20	20	125	20.3	15				
ADKT-151.23-R/L-2525-2.5-T15	●	●	25	25	150	25.3	15				
ADKT-151.23-R/L-1212-3-T15	●	●	12	12	100	16.4	15	151.2 - 3	2004-M8x1x20	-	AAL-05-4
ADKT-151.23-R/L-1616-3-T15	●	●	16	16	125	16.4	15				
ADKT-151.23-R/L-2020-3-T20	●	●	20	20	125	20.4	20				
ADKT-151.23-R/L-2525-3-T20	●	●	25	25	150	25.4	20	151.2 - 4	2004-M8x1x20	-	AAL-05-4
ADKT-151.23-R/L-2525-3-T22	●	●	25	25	150	25.4	22				
ADKT-151.23-R/L-1616-4-T15	●	●	16	16	125	16.4	15				
ADKT-151.23-R/L-2020-4-T20	●	●	20	20	125	20.4	20	151.2 - 5	2004-M8x1x20	-	AAL-05-4
ADKT-151.23-R/L-2525-4-T22	●	●	25	25	150	25.4	22				
ADKT-151.23-R/L-2020-5-T20	●	●	20	20	125	20.5	20	151.2 - 5	2004-M8x1x20	-	AAL-05-4
ADKT-151.23-R/L-2525-5-T25	●	●	25	25	150	25.5	25				

R: Derecha / Droite / Right L: Izquierda / Gauche / Left

● En Existencia / En stock / In Stock ○ Artículo sin Existencia / Indisponible en Stock / Non Stock Item

Compatible con el Inserto SNDVK. / Compatible avec SNDVK Plaquettes. / Compatible with SNDVK Insert.

Ejemplo de Pedido / Exemple de Commande / Ordering Example

1 Piezas / pcs. / pcs. ADKT-151.22-R-1616-2-T15

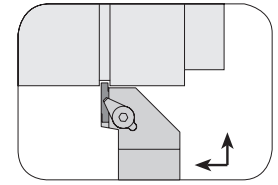
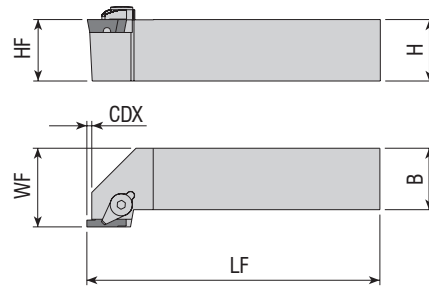

Código del Inserto Le Code de Commande Ordering Code	Stock		Dimension (mm) Dimension (mm) Dimension (mm)					Inserto Plaquelette Insert	Recambios / Pièces de Rechange / Spare Parts				
	R	L	HF=H	B	LF	WF	CDX		Abrazadera de Cuñas Mode de Fixation Wedge Clamp	Tornillo Vis Screw	Arandela Timbre Washer	Llaves Allen Clés Allen Allen Wrench	
ADKT-154.91-R/L-2020-3-T4	●	●	20	20	125	25	4						
ADKT-154.91-R/L-2525-3-T4	●	●	25	25	150	30.5	4						
ADKT-154.91-R/L-2020-5-T5	●	●	20	20	125	25	5		ACK-03	AKV-07-M6x22	APM-06	AAL-03-3	
ADKT-154.91-R/L-2525-5-T5	●	●	25	25	150	30.5	5						

Compatible con el Inserto SNDVK. / Compatible avec SNDVK Plaqueettes. / Compatible with SNDVK Insert.

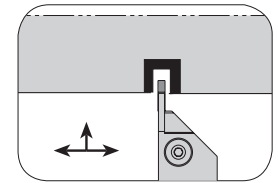
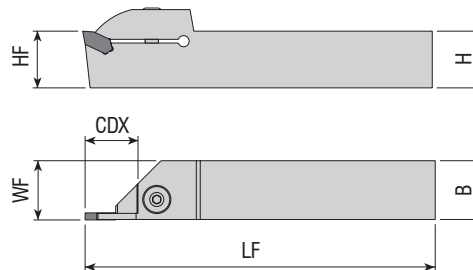

Código del Inserto Le Code de Commande Ordering Code	Stock		Dimension (mm) Dimension (mm) Dimension (mm)					Inserto Plaquelette Insert	Recambios / Pièces de Rechange / Spare Parts			
	R	L	HF=H	B	LF	WF	CDX		Tornillo Vis Screw	Arandela Timbre Washer	Llaves Allen Clés Allen Allen Wrench	
ADKT-ARN-R/L-2020-2-T15	●	●	20	20	125	20.3	15					
ADKT-ARN-R/L-2525-2-T15	●	●	25	25	150	25.3	15					
ADKT-ARN-R/L-2020-3-T20	●	●	20	20	125	20.4	20			-		
ADKT-ARN-R/L-2525-3-T22	●	●	25	25	150	25.4	22					

R: Derecha / Droite / Right L: Izquierda / Gauche / Left

● En Existencia / En stock / In Stock ○ Artículo sin Existencia / Indisponible en Stock / Non Stock Item

Compatible con el Inserto ARN. / Compatible avec ARN Plaqueettes. / Compatible with ARN Insert.

Ejemplo de Pedido / Exemple de Commande / Ordering Example

1 Piezas / pcs. / pcs. ADKT-154.91-R-2020-3-T4

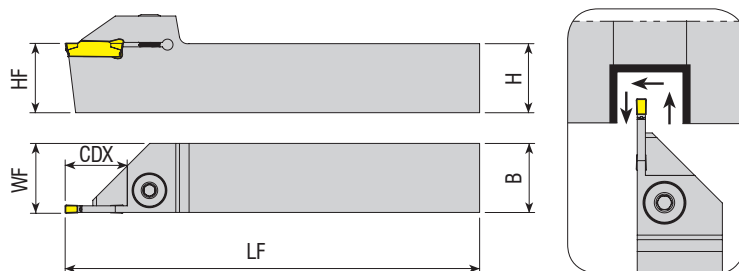

Código del Inserto Le Code de Commande Ordering Code	Stock Stock		Dimension (mm) Dimension (mm) Dimension (mm)				Inserto Plaquette Insert	Recambios / Pièces de Rechange / Spare Parts			
	R	L	HF=H	B	LF	WF		CDX	Tornillo Vis Screw	Arandela Timbre Washer	Llaves Allen Clés Allen Allen Wrench
ADKT-TD-R/L-1212-2-T15	●	●	12	12	100	12.2	15	TD. - 2	AKV-02-M6x22	ABPL-01	AAL-03-3
ADKT-TD-R/L-1616-2-T8	●	●	16	16	125	16.2	8				
ADKT-TD-R/L-1616-2-T15	●	●	16	16	125	16.2	15				
ADKT-TD-R/L-2020-2-T9	●	○	20	20	125	20.2	9				
ADKT-TD-R/L-2020-2-T15	●	●	20	20	125	20.2	15				
ADKT-TD-R/L-2020-2-T17	●	○	20	20	125	20.2	17				
ADKT-TD-R/L-2020-2-T20	●	○	20	20	125	20.2	20				
ADKT-TD-R/L-2525-2-T8	●	●	25	25	150	25.2	8				
ADKT-TD-R/L-2525-2-T17	●	●	25	25	150	25.2	17				
ADKT-TD-R/L-1212-3-T15	●	●	12	12	100	12.4	15				
ADKT-TD-R/L-1616-3-T15	●	●	16	16	125	16.4	15				
ADKT-TD-R/L-2020-3-T12	●	●	20	20	125	20.4	12				
ADKT-TD-R/L-2020-3-T20	●	●	20	20	125	20.4	20				
ADKT-TD-R/L-2020-3-T25	●	○	20	20	125	20.4	25				
ADKT-TD-R/L-2020-3-T30	●	●	20	20	125	20.4	30				
ADKT-TD-R/L-2525-3-T9	●	●	25	25	150	25.4	9				
ADKT-TD-R/L-2525-3-T12	●	●	25	25	150	25.4	12				
ADKT-TD-R/L-2525-3-T22	●	●	25	25	150	25.4	22				
ADKT-TD-R/L-2525-3-T25	●	●	25	25	150	25.4	25				
ADKT-TD-R/L-2525-3-T30	●	●	25	25	150	25.4	30				
ADKT-TD-R/L-3232-3-T25	●	○	32	32	170	32.4	25	TD. - 4			
ADKT-TD-R/L-2525-4-T10	●	●	25	25	150	25.5	10				
ADKT-TD-R/L-2525-4-T15	●	●	25	25	150	25.5	15				
ADKT-TD-R/L-2525-4-T22	●	●	25	25	150	25.5	22				
ADKT-TD-R/L-2525-4-T25	●	○	25	25	150	25.5	25				
ADKT-TD-R/L-2525-4-T30	●	○	25	25	150	25.5	30	TD. - 5			

R: Derecha / Droite / Right L: Izquierda / Gauche / Left

● En Existencia / En stock / In Stock ○ Artículo sin Existencia / Indisponible en Stock / Non Stock Item
 Compatible con el Inserto TGTC. / Compatible avec TGTC Plaquettes. / Compatible with TGTC Insert.

Ejemplo de Pedido / Exemple de Commande / Ordering Example

1 Piezas / pcs. / pcs. ADKT-TD-R-1212-2-T15

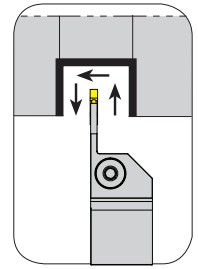
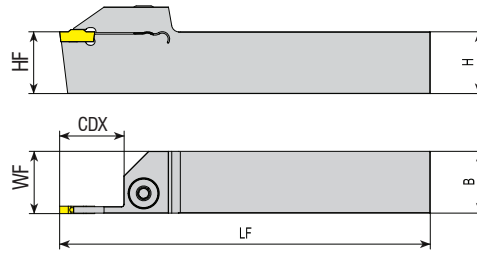

Código del Inserto
 Le Code de Commande
 Ordering Code

R	L	HF=H	B	Dimension (mm) Dimension (mm)			Inserto Plaquelette Insert	Recambios / Pièces de Rechange / Spare Parts		
				LF	WF	CDX		Tornillo Vis Screw	Arandela Timbre Washer	Llaves Allen Clés Allen Allen Wrench
●	○	16	16	125	16,2	17	RD. - 2	AKV-02-M6x22	ABPL-01	AAL-03-3
●	○	20	20	125	20,2	17				
●	●	25	25	150	25,2	17				
●	○	16	16	125	16,3	20	RD. - 3	2004-M8x1x20	-	AAL-05-4
●	○	20	20	125	20,3	25				
●	●	25	25	150	25,3	25				
●	○	20	20	125	20,5	30	RD. - 4	2004-M8x1x20	-	AAL-05-4
●	●	25	25	150	25,5	30				

Compatible con el Inserto TGTC. / Compatible avec TGTC Plaquettes. / Compatible with TGTC Insert.

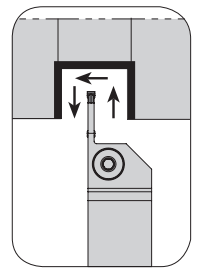
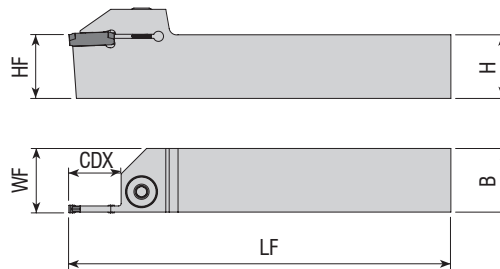

Código del Inserto
 Le Code de Commande
 Ordering Code

R	L	HF=H	B	Dimension (mm) Dimension (mm)			Inserto Plaquelette Insert	Recambios / Pièces de Rechange / Spare Parts		
				LF	WF	CDX		Tornillo Vis Screw	Arandela Timbre Washer	Llaves Allen Clés Allen Allen Wrench
●	●	16	16	125	16,2	20	GCTX - 2	AKV-02-M6x22	ABPL-01	AAL-03-3
●	●	20	20	125	20,2	20				
●	●	25	25	150	25,2	20				
●	●	16	16	125	16,3	20	GCTX - 3	2004-M8x1x20	-	AAL-05-4
●	●	20	20	125	20,3	20				
●	●	25	25	150	25,3	20				

R: Derecha / Droite / Right L: Izquierda / Gauche / Left

● En Existencia / En stock / In Stock ○ Artículo sin Existencia / Indisponible en Stock / Non Stock Item

Compatible con el Inserto LMN. / Compatible avec LMN Plaquettes. / Compatible with LMN Insert.

Ejemplo de Pedido / Exemple de Commande / Ordering Example

1 Piezas / pcs. / pcs. ADKT-RD-R-1616-2-T17

PORTA HERRAMIENTAS DE RANURADO EXTERNO
 PORTE-OUTILS EXTERIEUR A RAINURER
 EXTERNAL GROOVING TOOLHOLDERS

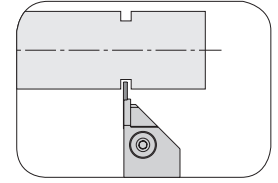
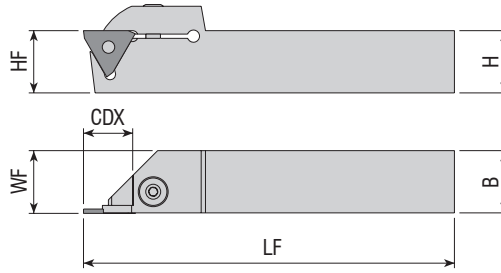

Código del Inserto Le Code de Commande Ordering Code	Stock Stock Stock		Dimension (mm) Dimension (mm) Dimension (mm)				Inserto Plaquette Insert	Recambios / Pièces de Rechange / Spare Parts				
	R	L	HF=H	B	LF	WF		CDX	Tornillo Vis Screw	Abrazadera de Cuñas Mode de Fixation Wedge Clamp	Arandela Timbre Washer	Llaves Allen Clés Allen Allen Wrench
ADKT-H22-R/L-1616-(0.5-2)-T4	●	●	16	16	125	16.2	4	S312 - (0.5-2)	AKV-29-M6x29	AKK-04	AS-01	AAL-03-3
ADKT-H22-R/L-2020-(0.5-2)-T4	●	●	20	20	125	20.2	4					
ADKT-H22-R/L-2525-(0.5-2)-T4	●	●	25	25	150	25.2	4					

Compatible con el Inserto HRN. / Compatible avec HRN Plaquettes. / Compatible with HRN Insert.

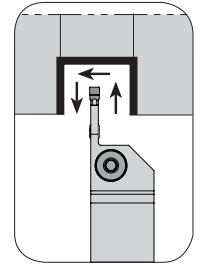
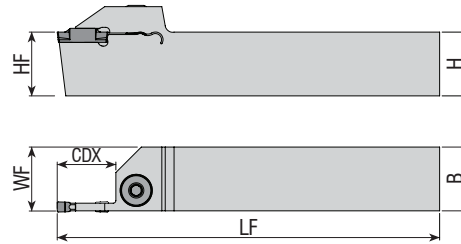
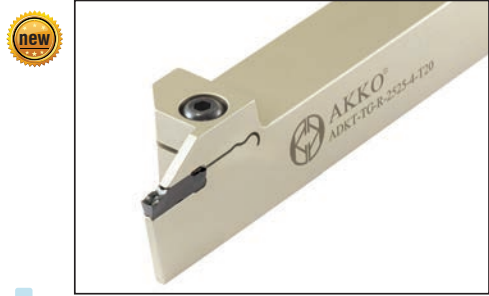

Código del Inserto Le Code de Commande Ordering Code	Stock Stock Stock		Dimension (mm) Dimension (mm) Dimension (mm)				Inserto Plaquette Insert	Recambios / Pièces de Rechange / Spare Parts			
	R	L	HF=H	B	LF	WF		CDX	Tornillo Vis Screw	Arandela Timbre Washer	Llaves Allen Clés Allen Allen Wrench
ADKT-TG-R/L-1616-2-R17	●	○	16	16	125	16.2	17	DGM2-020	AKV-02-M6x22	ABPL-01	AAL-03-3
ADKT-TG-R/L-2020-2-T8	●	○	20	20	125	20.2	8				
ADKT-TG-R/L-2020-2-R12	●	○	20	20	125	20.2	12				
ADKT-TG-R/L-2020-2-R17	●	○	20	20	125	20.2	17	DGM3-020	2004-M8x1x20	-	AAL-05-4
ADKT-TG-R/L-2525-2-R12	●	○	25	25	150	25.2	12				
ADKT-TG-R/L-2525-2-R17	●	○	25	25	150	25.2	17				
ADKT-TG-R/L-1616-3-T20	●	○	16	16	125	16.3	20	DGM4-030	2004-M8x1x20	-	AAL-05-4
ADKT-TG-R/L-2020-3-T12	●	○	20	20	125	20.3	12				
ADKT-TG-R/L-2020-3-T20	●	○	20	20	125	20.3	20				
ADKT-TG-R/L-2525-3-T9	●	○	25	25	150	25.3	9	DGM5-030	2004-M8x1x20	-	AAL-05-4
ADKT-TG-R/L-2525-3-T20	●	○	25	25	150	25.3	20				
ADKT-TG-R/L-2525-3-R25	●	○	25	25	150	25.3	25				
ADKT-TG-R/L-2525-4-T15	●	○	25	25	150	25.5	15	DGM5-030	2004-M8x1x20	-	AAL-05-4
ADKT-TG-R/L-2525-4-T20	●	○	25	25	150	25.5	20				
ADKT-TG-R/L-2525-4-T25	●	○	25	25	150	25.5	25				
ADKT-TG-R/L-2525-5-T12	●	○	25	25	150	25.5	12	DGM5-030	2004-M8x1x20	-	AAL-05-4
ADKT-TG-R/L-2525-5-T25	●	○	25	25	150	25.5	25				
ADKT-TG-R/L-2525-5-T32	●	○	25	25	150	25.5	32				

R: Derecha / Droite / Right L: Izquierda / Gauche / Left

● En Existencia / En stock / In Stock ○ Artículo sin Existencia / Indisponible en Stock / Non Stock Item
 Compatible con el Inserto TNGLY. / Compatible avec TNGLY Plaquettes. / Compatible with TNGLY Insert.

Ejemplo de Pedido / Exemple de Commande / Ordering Example

1 Piezas / pcs. / pcs. ADKT-H22-R-1616-(0.5-2)T4



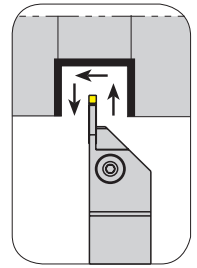
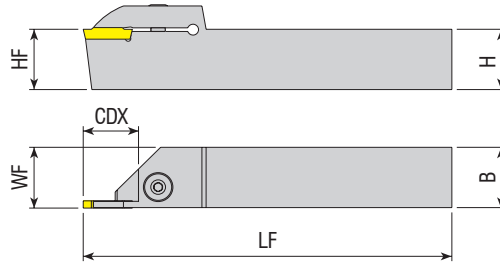

Código del Inserto Le Code de Commande Ordering Code	Stock Stock Stock		Dimension (mm) Dimension (mm) Dimension (mm)				Inserto Plaquette Insert	Recambios / Pièces de Rechange / Spare Parts			
	R	L	HF=H	B	LF	WF		CDX	Tornillo Vis Screw	Arandela Timbre Washer	Llaves Allen Cles Allen Allen Wrench
ADKT-WGX16-R/L-2020-2-R16	●	○	20	20	125	20.2	16	GX16. - 2	AKV-02-M6x22	ABPL-01	AAL-03-3
ADKT-WGX16-R/L-2525-2-R16	●	○	25	25	150	25.2	16				
ADKT-WGX24-R/L-2020-3-T20	●	●	20	20	125	20.4	20	GX24. - 3	2004-M8x1x20	-	AAL-05-4
ADKT-WGX24-R/L-2525-3-T12	●	●	25	25	150	25.4	12				
ADKT-WGX24-R/L-2525-3-T22	●	●	25	25	150	25.4	22				
ADKT-WGX24-R/L-3232-3-T22	●	○	32	32	170	32.4	22				
ADKT-WGX24-R/L-2525-4-T22	●	●	25	25	150	25.5	22				
ADKT-WGX24-R/L-2525-5-T25	●	●	25	25	150	25.5	25	GX24. - 5			
ADKT-WGX24-R/L-3232-5-T25	●	●	32	32	170	32.5	25				

Compatible con el Inserto WLTR. / Compatible avec WLTR Plaquettes. / Compatible with WLTR Insert.

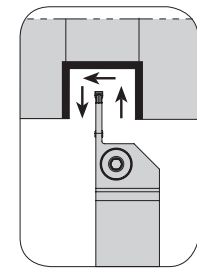
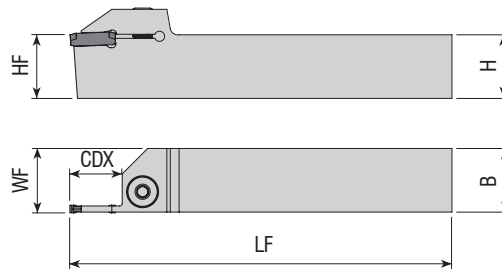

Código del Inserto Le Code de Commande Ordering Code	Stock Stock Stock		Dimension (mm) Dimension (mm) Dimension (mm)				Inserto Plaquette Insert	Recambios / Pièces de Rechange / Spare Parts			
	R	L	HF=H	B	LF	WF		CDX	Tornillo Vis Screw	Arandela Timbre Washer	Llaves Allen Cles Allen Allen Wrench
ADKT-GP-R/L-2020-2-T15	●	●	20	20	125	20.2	15	GP - 2	AKV-02-M6x22	ABPL-01	AAL-03-3
ADKT-GP-R/L-2525-2-T15	●	●	25	25	150	25.2	15				
ADKT-GP-R/L-2020-3-T20	●	●	20	20	125	20.3	20	GP - 3	2004-M8x1x20	-	AAL-05-4
ADKT-GP-R/L-2525-3-T22	●	●	25	25	150	25.3	22				
ADKT-GP-R/L-2525-4-T22	●	●	25	25	150	25.4	22				
ADKT-GP-R/L-2525-5-T25	●	●	25	25	150	25.5	25				
ADKT-GP-R/L-2525-5-T25	●	●	25	25	150	25.5	25				

R: Derecha / Droite / Right L: Izquierda / Gauche / Left

● En Existencia / En stock / In Stock ○ Artículo sin Existencia / Indisponible en Stock / Non Stock Item
Compatible con el Inserto PLBT. / Compatible avec PLBT Plaquettes. / Compatible with PLBT Insert.

Ejemplo de Pedido / Exemple de Commande / Ordering Example

1 Piezas / pcs. / pcs. ADKT-WGX16-R-2020-2-R16

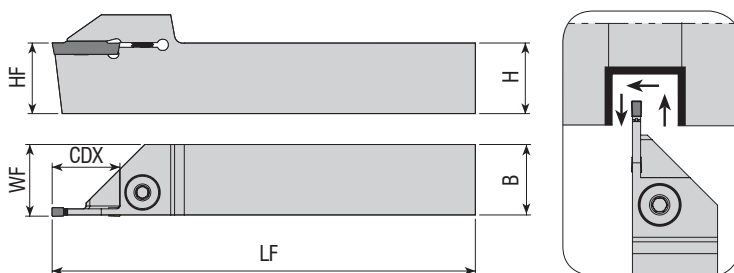

Código del Inserto Le Code de Commande Ordering Code	Stock Stock		Dimension (mm) Dimension (mm) Dimension (mm)				Inserto Plaquette Insert	Recambios / Pièces de Rechange / Spare Parts			
	R	L	HF=H	B	LF	WF		CDX	Tornillo Vis Screw	Arandela Timbre Washer	Llaves Allen Clés Allen Allen Wrench
ADKT-CD-R/L-2020-3-R20	●	○	20	20	125	20.3	20	GX24 0300	2004-M8x1x20	-	AAL-05-4
ADKT-CD-R/L-2525-3-R23	●	○	25	25	150	25.3	23				

Compatible con el Inserto CRTZT. / Compatible avec CRTZT Plaquettes. / Compatible with CRTZT Insert.

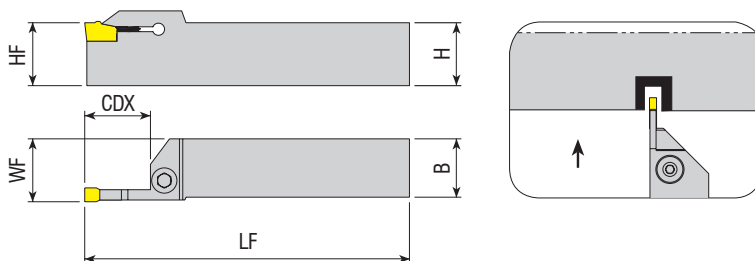

Código del Inserto Le Code de Commande Ordering Code	Stock Stock		Dimension (mm) Dimension (mm) Dimension (mm)				Inserto Plaquette Insert	Recambios / Pièces de Rechange / Spare Parts			
	R	L	HF=H	B	LF	WF		CDX	Tornillo Vis Screw	Arandela Timbre Washer	Llaves Allen Clés Allen Allen Wrench
ADKT-SWC-R/L-2020-2-T25	●	○	20	20	125	20.3	25	WCF - 2	AKV-02-M6x22	ABPL-01	AAL-03-3
ADKT-SWC-R/L-2020-3-T25	●	○	20	20	125	20.4	25				

R: Derecha / Droite / Right L: Izquierda / Gauche / Left

● En Existencia / En stock / In Stock ○ Artículo sin Existencia / Indisponible en Stock / Non Stock Item
 Compatible con el Inserto SMTM. / Compatible avec SMTM Plaquettes. / Compatible with SMTM Insert.

Ejemplo de Pedido / Exemple de Commande / Ordering Example

1 Piezas / pcs. / pcs. ADKT-CD-R-2020-3-R20

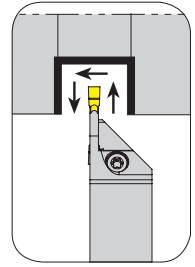
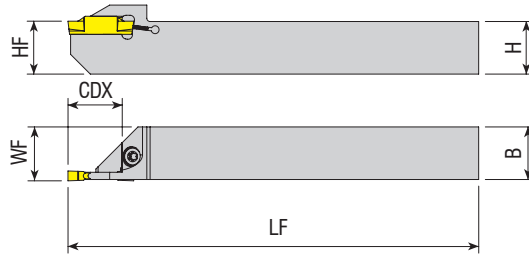

Código del Inserto Le Code de Commande Ordering Code	Stock Stock Stock		Dimension (mm) Dimension (mm) Dimension (mm)				Inserto Plaquette Insert	Recambios / Pièces de Rechange / Spare Parts			
	R	L	HF=H	B	LF	WF		CDX	Tornillo Vis Screw	Arandela Timbre Washer	Llave Torx Clé Torx Torx Wrench
	ADKT-TD-R/L-1212-2-T12-K-S	●	●	12	12	125		12.2	12	TD. - 2	4015-M4x11
ADKT-TD-R/L-1616-2-T16-K-S	●	●	16	16	125	16.2	16				
ADKT-TD-R/L-1212-3-T12-K-S	●	●	12	12	125	12.3	12	TD. - 3	4015-M4x11	-	80-T15
ADKT-TD-R/L-1616-3-T16-K-S	●	●	16	16	125	16.3	16				

Compatible con el Inserto TGTC. / Compatible avec TGTC Plaquettes. / Compatible with TGTC Insert.

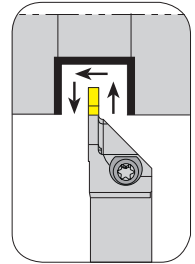
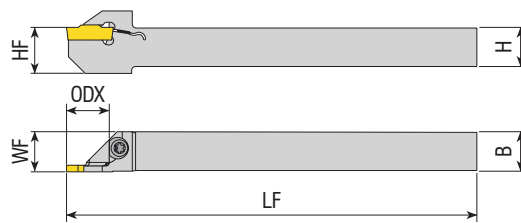

Código del Inserto Le Code de Commande Ordering Code	Stock Stock Stock		Dimension (mm) Dimension (mm) Dimension (mm)				Inserto Plaquette Insert	Recambios / Pièces de Rechange / Spare Parts			
	R	L	HF=H	B	LF	WF		CDX	Tornillo Vis Screw	Arandela Timbre Washer	Llave Torx Clé Torx Torx Wrench
	ADKT-RD-R/L-1212-2-T12-K-S	●	●	12	12	125		12.2	12	RD. - 2	4015-M4x11
ADKT-RD-R/L-1616-2-T17-K-S	○	●	16	16	125	16.2	17				
ADKT-RD-R/L-1212-3-T12-K-S	●	●	12	12	125	12.2	12	RD. - 3	4015-M4x11	-	80-T15

R: Derecha / Droite / Right L: Izquierda / Gauche / Left

● En Existencia / En stock / In Stock ○ Artículo sin Existencia / Indisponible en Stock / Non Stock Item
 Compatible con el Inserto TGTC. / Compatible avec TGTC Plaquettes. / Compatible with TGTC Insert.

Ejemplo de Pedido / Exemple de Commande / Ordering Example

1 Piezas / pcs. / pcs. ADKT-TD-R-1212-2-T12-K-S

PORTA HERRAMIENTAS DE RANURADO EXTERNO PARA TORNOS AUTOMÁTICOS CORREDIZOS TIPO SUIZO
 PORTE-OUTILS DE RAINURAGE EXTERIEUR POUR MACHINES DE TYPES SWISS
 EXTERNAL GROOVING TOOLHOLDERS FOR SWISS TYPE SLIDING AUTOMATIC LATHES

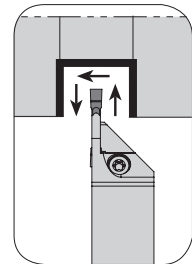
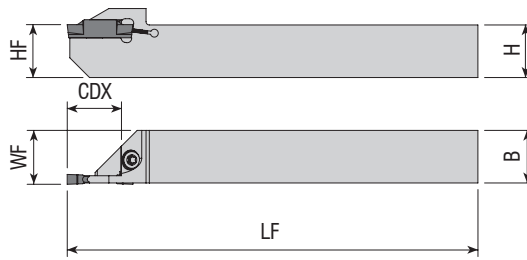

Código del Inserto Le Code de Commande Ordering Code	Stock Stock Stock		Dimension (mm) Dimension (mm) Dimension (mm)					Inserto Plaquette Insert	Recambios / Pièces de Rechange / Spare Parts		
	R	L	HF=H	B	LF	WF	CDX		Tornillo Vis Screw	Arandela Timbre Washer	Llave Torx Clé Torx Torx Wrench
ADKT-ZCC2-R/L-1010-2-T12-K-S	●	●	10	10	125	10.2	12	Z.BD - 2	4015-M4x11	-	80-T15
ADKT-ZCC2-R/L-1212-2-T12-K-S	●	●	12	12	125	12.2	12				
ADKT-ZCC2-R/L-1616-2-R16-K-S	●	●	16	16	125	16.2	16	Z.FD - 3			
ADKT-ZCC2-R/L-1212-3-T12-K-S	●	●	12	12	125	12.3	12				

Compatible con el Inserto ZCC. / Compatible avec ZCC Plaquettes. / Compatible with ZCC Insert.

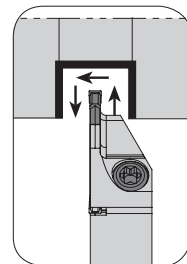
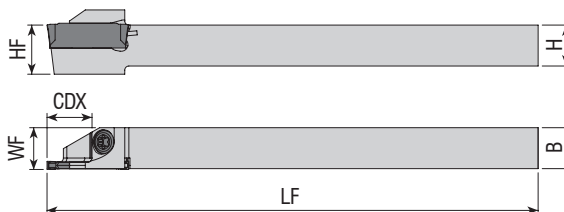
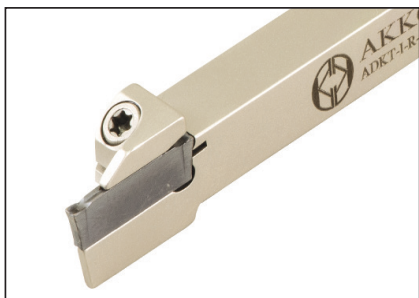

Código del Inserto Le Code de Commande Ordering Code	Stock Stock Stock		Dimension (mm) Dimension (mm) Dimension (mm)					Inserto Plaquette Insert	Recambios / Pièces de Rechange / Spare Parts		
	R	L	HF=H	B	LF	WF	CDX		Tornillo Vis Screw	Arandela Timbre Washer	Llave Torx Clé Torx Torx Wrench
ADKT-I-R/L-0808-2-R10-S	●	●	08	08	100	8.2	10	DGN - 2	4015-M4x11	-	80-T15
ADKT-I-R/L-1010-2-R10-K-S	●	●	10	10	125	10.2	10				
ADKT-I-R/L-1212-2-R12-K-S	●	●	12	12	125	12.2	12	DGN - 3			
ADKT-I-R/L-1616-3-R16-K-S	●	●	16	16	125	16.3	16				

R: Derecha / Droite / Right L: Izquierda / Gauche / Left

● En Existencia / En stock / In Stock ○ Artículo sin Existencia / Indisponible en Stock / Non Stock Item

Compatible con el Inserto SMTM. / Compatible avec SMTM Plaquettes. / Compatible with SMTM Insert.

Ejemplo de Pedido / Exemple de Commande / Ordering Example

1 Piezas / pcs. / pcs. ADKT-ZCC2-R-1010-2-T12-K-S

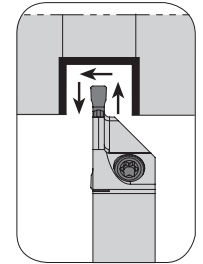
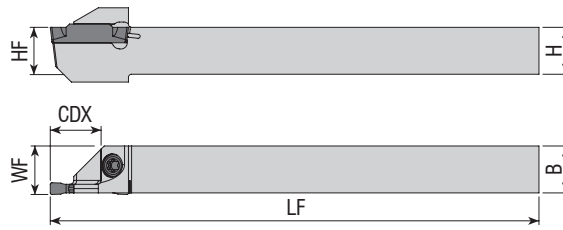

Código del Inserto Le Code de Commande Ordering Code	Stock Stock Stock		Dimension (mm) Dimension (mm) Dimension (mm)				Inserto Plaque Insert	Recambios / Pièces de Rechange / Spare Parts			
	R	L	HF=H	B	LF	WF		CDX	Tornillo Vis Screw	Arandela Timbre Washer	Llave Torx Clé Torx Torx Wrench
ADKT-KG-R/L-1212-2-R12-K-S	●	●	12	12	125	12.2	12	KG. - 2	4015-M4x11	-	80-T15
ADKT-KG-R/L-1616-2-R16-K-S	●	●	16	16	125	16.2	16				
ADKT-KG-R/L-1212-3-R12-K-S	●	●	12	12	125	12.3	12	KG. - 3	4015-M4x11	-	80-T15
ADKT-KG-R/L-1616-3-R16-K-S	●	●	16	16	125	16.3	16				

Compatible con el Inserto KRLY. / Compatible avec KRLY Plaquettes. / Compatible with KRLY Insert.

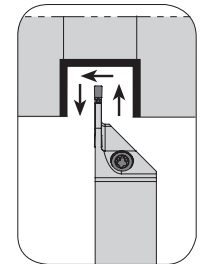
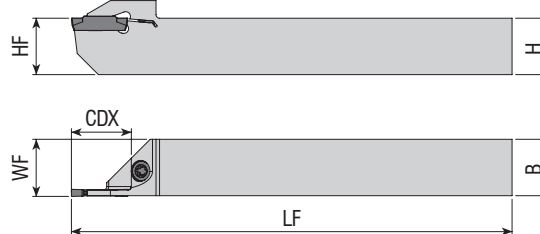

Código del Inserto Le Code de Commande Ordering Code	Stock Stock Stock		Dimension (mm) Dimension (mm) Dimension (mm)				Inserto Plaque Insert	Recambios / Pièces de Rechange / Spare Parts			
	R	L	HF=H	B	LF	WF		CDX	Tornillo Vis Screw	Arandela Timbre Washer	Llave Torx Clé Torx Torx Wrench
ADKT-K-R/L-1212-2-R12-K-S	●	●	12	12	125	12.20	12	MGM. - 2	4015-M4x11	-	80-T15
ADKT-K-R/L-1616-2-R16-K-S	●	●	16	16	125	16.20	16				
ADKT-K-R/L-1212-3-R12-K-S	●	●	12	12	125	12.30	12	MGM. - 3	4015-M4x11	-	80-T15
ADKT-K-R/L-1616-3-R16-K-S	●	●	16	16	125	16.30	16				

R: Derecha / Droite / Right L: Izquierda / Gauche / Left

● En Existencia / En stock / In Stock ○ Artículo sin Existencia / Indisponible en Stock / Non Stock Item
 Compatible con el Inserto KRLY. / Compatible avec KRLY Plaquettes. / Compatible with KRLY Insert.

Ejemplo de Pedido / Exemple de Commande / Ordering Example

1 Piezas / pcs. / pcs. ADKT-KG-R-1212-2-R12-K-S

PORTA HERRAMIENTAS DE RANURADO EXTERNO PARA TORNOS AUTOMÁTICOS CORREDIZOS TIPO SUIZO
 PORTE-OUTILS DE RAINURAGE EXTERIEUR POUR MACHINES DE TYPES SWISS
 EXTERNAL GROOVING TOOLHOLDERS FOR SWISS TYPE SLIDING AUTOMATIC LATHES

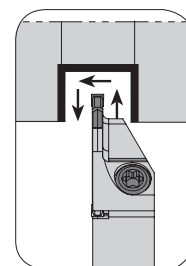
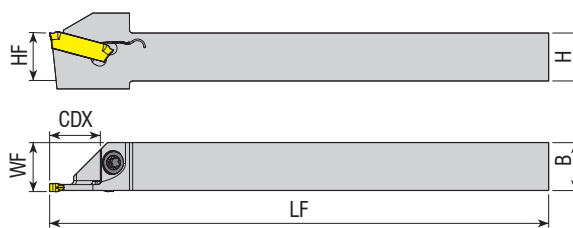

Código del Inserto Le Code de Commande Ordering Code	Stock Stock Stock		Dimension (mm) Dimension (mm) Dimension (mm)					Inserto Plaquette Insert	Recambios / Pièces de Rechange / Spare Parts						
	R	L	HF=H	B	LF	WF	CDX		Tornillo Vis Screw	Arandela Timbre Washer	Llave Torx Clé Torx Torx Wrench				
ADKT-WGX16-R/L-1212-2-R12-K-S	●	●	12	12	125	12.2	12								
ADKT-WGX16-R/L-1616-2-R16-K-S	●	○	16	16	125	16.2	16					GX16. - 2	4015-M4x11	-	80-T15
ADKT-WGX24-R/L-1616-3-R16-K-S	●	○	16	16	125	16.3	16								

Compatible con el Inserto WLTR. / Compatible avec WLTR Plaquettes. / Compatible with WLTR Insert.

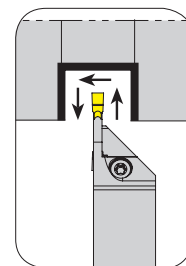
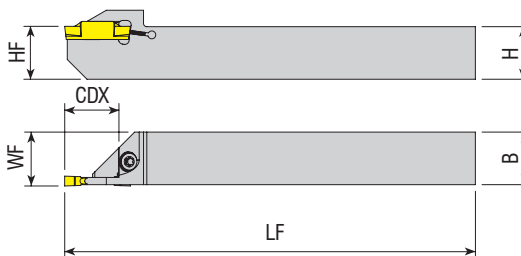

Código del Inserto Le Code de Commande Ordering Code	Stock Stock Stock		Dimension (mm) Dimension (mm) Dimension (mm)					Inserto Plaquette Insert	Recambios / Pièces de Rechange / Spare Parts		
	R	L	HF=H	B	LF	WF	CDX		Tornillo Vis Screw	Arandela Timbre Washer	Llave Torx Clé Torx Torx Wrench
ADKT-TG-R/L-1212-2-R12-K-S	●	○	12	12	125	12.2	12				
ADKT-TG-R/L-1212-3-R12-K-S	●	○	12	12	125	12.3	12				

R: Derecha / Droite / Right L: Izquierda / Gauche / Left

● En Existencia / En stock / In Stock ○ Artículo sin Existencia / Indisponible en Stock / Non Stock Item
 Compatible con el Inserto TNGLY. / Compatible avec TNGLY Plaquettes. / Compatible with TNGLY Insert.

Ejemplo de Pedido / Exemple de Commande / Ordering Example

1 Piezas / pcs. / pcs. ADKT-WGX16-R-1212-2-R12-K-S

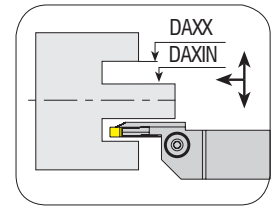
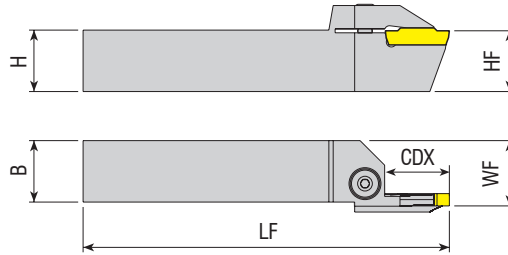

Código del Inserto Le Code de Commande Ordering Code	Stock		Dimension (mm) Dimension (mm)							Inserto Plaquette Insert	Recambios / Pièces de Rechange / Spare Parts		
	R	L	HF=H	B	LF	WF	CDX	DAXIN	DAXX		Tornillo Vis Screw	Arandela Timbre Washer	Llaves Allen Clés Allen Allen Wrench
AAKT-K-R/L-2525-34-45-3-T17	●	●	25	25	150	26.5	17	34	45	MGM. - 3			
AAKT-K-R/L-2525-39-55-3-T17	●	●	25	25	150	26.5	17	39	55				
AAKT-K-R/L-2525-49-80-3-T17	●	●	25	25	150	26.5	17	49	80				
AAKT-K-R/L-2525-70-110-3-T17	●	●	25	25	150	26.5	17	70	110				
AAKT-K-R/L-2525-100-150-3-T17	●	●	25	25	150	26.5	17	100	150				
AAKT-K-R/L-2525-80-180-3-T32	●	●	25	25	150	26.5	32	80	180				
AAKT-K-R/L-2525-175-215-3-T22	●	●	25	25	150	26.5	22	175	215				
AAKT-K-R/L-2525-700-800-3-T17	●	●	25	25	150	26.5	17	700	800	MGM. - 4	2004-M8x1x20	-	AAL-05-4
AAKT-K-R/L-2525-50-85-4-T22	●	●	25	25	150	26.5	22	50	85				
AAKT-K-R/L-2525-70-110-4-T22	●	●	25	25	150	26.5	22	70	110				
AAKT-K-R/L-2525-100-150-4-T22	●	●	25	25	150	26.5	22	100	150				
AAKT-K-R/L-2525-80-180-4-T32	●	●	25	25	150	26.5	32	80	180				
AAKT-K-R/L-2525-180-800-4-T32	●	●	25	25	150	26.5	32	180	800	MGM. - 5			
AAKT-K-R/L-2525-70-110-5-T25	●	●	25	25	150	26.5	25	70	110				
AAKT-K-R/L-2525-100-150-5-T25	●	●	25	25	150	26.5	25	100	150				
AAKT-K-R/L-2525-80-180-5-T32	●	●	25	25	150	26.5	32	80	180				
AAKT-K-R/L-2525-140-200-5-T25	●	●	25	25	150	26.5	25	140	200	MGM. - 6			
AAKT-K-R/L-2525-180-800-5-T32	●	●	25	25	150	26.5	32	180	800				
AAKT-K-R/L-2525-60-100-6-T25	●	●	25	25	150	26.5	25	60	100				
AAKT-K-R/L-2525-60-100-6-T35	●	○	25	25	150	26.5	35	60	100	MGM. - 8			
AAKT-K-R/L-2525-100-200-6-T25	●	○	25	25	150	26.5	25	100	200				
AAKT-K-R/L-2525-100-200-6-T35	●	○	25	25	150	26.5	35	100	200				
AAKT-K-R/L-2525-100-200-6-T45	●	○	25	25	150	26.5	45	100	200	MGM. - 8			
AAKT-K-R/L-2525-140-300-6-T35	●	●	25	25	150	26.5	35	140	300				
AAKT-K-R/L-2525-140-300-8-T35	●	○	25	25	150	26.5	35	140	300	MGM. - 8			
AAKT-K-R/L-3232-140-350-8-T35	●	○	32	32	150	33.5	35	140	350				

R: Derecha / Droite / Right L: Izquierda / Gauche / Left

● En Existencia / En stock / In Stock ○ Artículo sin existencia / Indisponible en Stock / Non Stock Item
 Compatible con el Inserto TNGLY. / Compatible avec TNGLY Plaquettes. / Compatible with TNGLY Insert.

Ejemplo de Pedido / Exemple de Commande / Ordering Example

1 Piezas / pcs. / pcs. AAKT-K-R-2525-34-45-3-T17

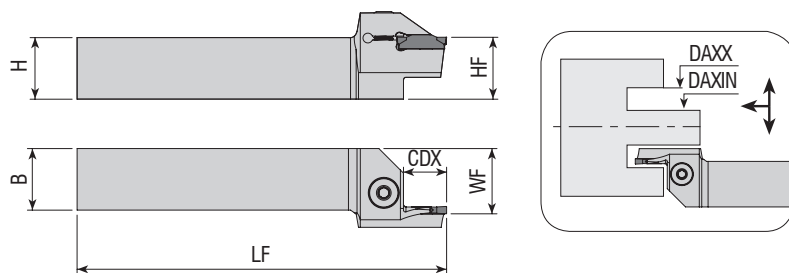

Código del Inserto Le Code de Commande Ordering Code	Stock		Dimension (mm) Dimension (mm) Dimension (mm)							Inserto Plaquette Insert	Recambios / Pièces de Rechange / Spare Parts			
	R	L	HF=H	B	LF	WF	CDX	DAXIN	DAXX		Tornillo Vis Screw	Arandela Timbre Washer	Llaves Allen Clés Allen Allen Wrench	
AAKT-ZCC2-R/L-2525-140-180-2-T4	●	○	25	25	150	26.5	4	140	180	Z.BD - 2	2004-M8x1x20	-	AAL-05-4	
AAKT-ZCC2-R/L-2525-35-45-3-T17	●	●	25	25	150	26.5	17	35	45	Z.FD - 3				
AAKT-ZCC2-R/L-2525-39-55-3-T17	●	○	25	25	150	26.5	17	39	55					
AAKT-ZCC2-R/L-2525-49-80-3-T17	●	●	25	25	150	26.5	17	49	80					
AAKT-ZCC2-R/L-2525-70-110-3-T15	●	○	25	25	150	26.5	15	70	110					
AAKT-ZCC2-R/L-2525-70-110-3-T17	●	●	25	25	150	26.5	17	70	110					
AAKT-ZCC2-R/L-2525-100-150-3-T17	●	●	25	25	150	26.5	17	100	150		Z.GD - 4			
AAKT-ZCC2-R/L-2525-40-60-4-T22	●	○	25	25	150	26.5	22	40	60					
AAKT-ZCC2-R/L-2525-52-80-4-T22	●	●	25	25	150	26.5	22	52	80					
AAKT-ZCC2-R/L-2525-72-110-4-T22	●	●	25	25	150	26.5	22	72	110					
AAKT-ZCC2-R/L-2525-100-150-4-T22	●	●	25	25	150	26.5	22	100	150					
AAKT-ZCC2-R/L-2525-140-200-4-T22	●	●	25	25	150	26.5	22	140	200					
AAKT-ZCC2-R/L-2525-55-95-5-T25	●	○	25	25	150	26.5	25	55	95	Z.HD - 5				
AAKT-ZCC2-R/L-2525-85-140-5-T25	●	●	25	25	150	26.5	25	85	140					
AAKT-ZCC2-R/L-2525-130-200-5-T25	●	○	25	25	150	26.5	25	130	200					
AAKT-ZCC2-R/L-2525-190-400-5-T25	●	●	25	25	150	26.5	25	190	400					
AAKT-ZCC2-R/L-2525-190-400-5-T35	●	○	25	25	150	26.5	35	190	400					
AAKT-ZCC2-R/L-2525-200-500-5-T17	●	●	25	25	150	26.5	17	200	500					
AAKT-ZCC2-R/L-2525-60-110-6-T15	●	○	25	25	150	26.5	15	60	110	Z.KD - 6				

Kompatibel mit ZCC Wendeplatten. / Compatible con Inserti ZCC. / Compatible with ZCC Insert.

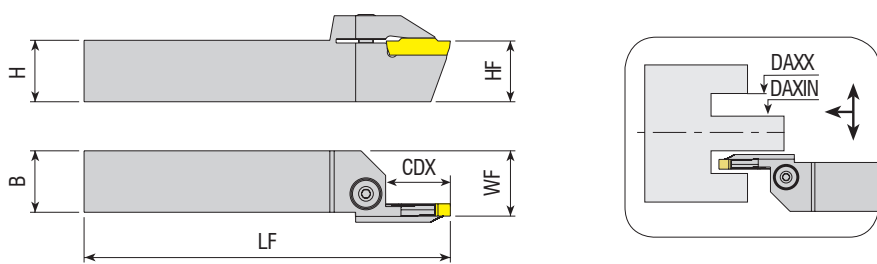

Código del Inserto Le Code de Commande Ordering Code	Stock		Dimension (mm) Dimension (mm) Dimension (mm)							Inserto Plaquette Insert	Recambios / Pièces de Rechange / Spare Parts			
	R	L	HF=H	B	LF	WF	CDX	DAXIN	DAXX		Tornillo Vis Screw	Arandela Timbre Washer	Llaves Allen Clés Allen Allen Wrench	
AAKT-KG-R/L-2525-44-70-4-T22	○	○	25	25	150	26.5	22	44	70	KG.. - 4	2004-M8x1x20	-	AAL-05-4	
AAKT-KG-R/L-2525-60-120-4-T22	○	○	25	25	150	26.5	22	60	120					
AAKT-KG-R/L-2525-112-200-4-T22	○	○	25	25	150	26.5	22	112	200					

R: Derecha / Droite / Right L: Izquierda / Gauche / Left
 ● En Existencia / En stock / In Stock ○ Artículo sin Existencia / Indisponible en Stock / Non Stock Item
 Compatible con el Inserto KRLY. / Compatible avec KRLY Plaquettes. / Compatible with KRLY Insert.

Ejemplo de Pedido / Exemple de Commande / Ordering Example
 1 Piezas / pcs. / pcs. AAKT-ZCC2-R-2525-140-180-2-T4

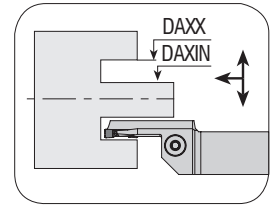
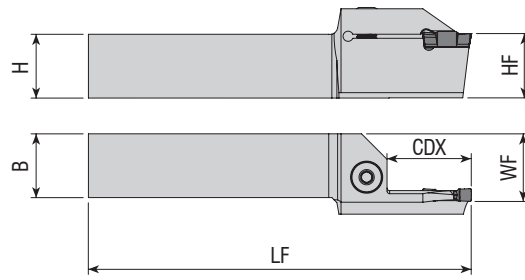

Código del Inserto
 Le Code de Commande
 Ordering Code

Stock Stock Stock	Dimension (mm) Dimension (mm) Dimension (mm)									Inserto Plaquette Insert	Recambios / Pièces de Rechange / Spare Parts		
	R	L	HF=H	B	LF	WF	CDX	DAXIN	DAXX		Tornillo Vis Screw	Arandela Timbre Washer	Llaves Allen Clés Allen Allen Wrench
AAKT-IG-R/L-2525-40-60-4-T25	●	●	25	25	150	26.5	25	40	60	DGN / GRP - 4	2004-M8x1x20	-	AAL-05-4
AAKT-IG-R/L-2525-52-80-4-T25	●	●	25	25	150	26.5	25	52	80				
AAKT-IG-R/L-2525-70-110-4-T28	●	●	25	25	150	26.5	28	70	110				
AAKT-IG-R/L-2525-72-110-4-T25	○	○	25	25	150	26.5	25	72	110				
AAKT-IG-R/L-2525-100-150-4-T25	●	○	25	25	150	26.5	25	100	150				
AAKT-IG-R/L-2525-110-200-4-T28	●	○	25	25	150	26.5	28	110	200				
AAKT-IG-R/L-2525-110-200-4-T32	●	●	25	25	150	26.5	32	110	200				
AAKT-IG-R/L-2525-140-200-4-T25	○	○	25	25	150	26.5	25	140	200				
AAKT-IG-R/L-2525-180-800-4-T28	●	●	25	25	150	26.5	28	180	800				
AAKT-IG-R/L-2525-200-800-4-T25	○	○	25	25	150	26.5	25	200	800				
AAKT-IG-R/L-2525-70-110-5-T32	●	●	25	25	150	26.5	32	70	110	DGN / GRP - 5			
AAKT-IG-R/L-2525-110-200-5-T9	●	○	25	25	150	26.5	9	110	200				
AAKT-IG-R/L-2525-110-200-5-T32	●	●	25	25	150	26.5	32	110	200				
AAKT-IG-R/L-2525-180-800-5-T32	●	●	25	25	150	26.5	32	180	800	DGN / GRP - 6			
AAKT-IG-R/L-2525-58-100-6-T32	●	○	25	25	150	26.5	32	58	100				
AAKT-IG-R/L-2525-88-180-6-T32	●	○	25	25	150	26.5	32	88	180				

R: Derecha / Droite / Right L: Izquierda / Gauche / Left
 ● En Existencia / En stock / In Stock ○ Artículo sin Existencia / Indisponible en Stock / Non Stock Item
 Compatible con el Inserto ISCR. / Compatible avec ISCR Plaquettes. / Compatible with ISCR Insert.

Ejemplo de Pedido / Exemple de Commande / Ordering Example
 1 Piezas / pcs. / pcs. AAKT-IG-R-2525-40-60-4-T25



SOPORTES EXTERIORES PARA HERRAMIENTAS DE RANURADO TIPO L
PORTE-OUTILS FACE EXTERIEUR A RAINURER TYPE-L
L TYPE FACE EXTERNAL GROOVING TOOLHOLDERS

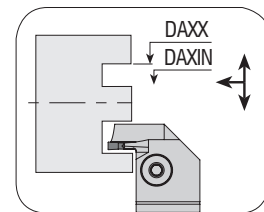
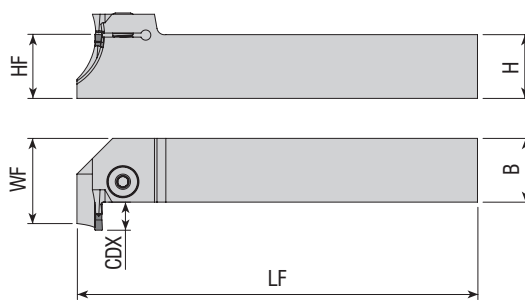

Código del Inserto Le Code de Commande Ordering Code	Stock Stock Stock		Dimension (mm) Dimension (mm) Dimension (mm)							Inserto Plaquette Insert	Recambios / Pièces de Rechange / Spare Parts		
	R	L	HF=H	B	LF	WF	CDX	DAXIN	DAXX		Tornillo Vis Screw	Arandela Timbre Washer	Llaves Allen Clés Allen Allen Wrench
ALKT-ZCC2-R/L-2525-35-45-3-T10	●	●	25	25	150	36	10	35	45	Z.FD - 3	2004-M8x1x20	-	AAL-05-4
ALKT-ZCC2-R/L-2525-39-55-3-T10	●	●	25	25	150	36	10	39	55				
ALKT-ZCC2-R/L-2525-35-∞-3-T4	●	●	25	25	150	30	4	35	∞	Z.GD - 4	2004-M8x1x20	-	AAL-05-4
ALKT-ZCC2-R/L-2525-40-60-4-T14	●	●	25	25	150	40	14	40	60				
ALKT-ZCC2-R/L-2525-52-80-4-T14	●	○	25	25	150	40	14	52	80	Z.GD - 4	2004-M8x1x20	-	AAL-05-4
ALKT-ZCC2-R/L-2525-72-110-4-T14	●	○	25	25	150	40	14	72	110				
ALKT-ZCC2-R/L-2525-100-230-4-T14	●	○	25	25	150	40	14	100	230	Z.GD - 4	2004-M8x1x20	-	AAL-05-4
ALKT-ZCC2-R/L-2525-40-∞-4-T4	●	●	25	25	150	30	4	40	∞				

Compatible con el Inserto ZCC. / Compatible avec ZCC Plaquettes. / Compatible with ZCC Insert.

CORTADORES PARA TROZADO Y RANURADO PROFUNDO
LAMES DE TRANÇONNAGE ET RAINURAGE PROFOND
BLADES FOR PARTING AND DEEP GROOVING

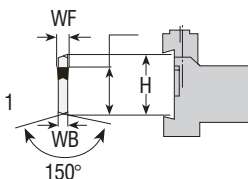
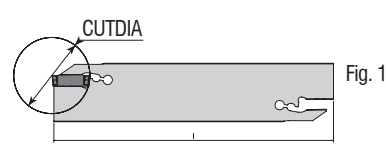
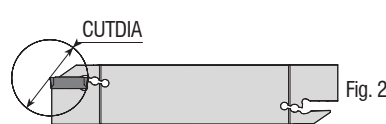
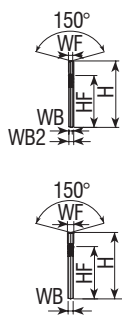

Código del Inserto Le Code de Commande Ordering Code	Stock Stock Stock		Dimension (mm) Dimension (mm) Dimension (mm)							Inserto Plaquette Insert	Recambios / Pièces de Rechange / Spare Parts
	H	WF	WB2	WB	I	HF	CUTDIA	Fig.	Llaves Allen Clés Allen Allen Wrench		
AKL-SGC-26-3	●	26	3	2.40	-	110	21.4	39	2	GCM N30	ALA-02
AKL-SGC-32-3	●	32	3	2.40	-	150	25	39	1		

R: Derecha / Droite / Right L: Izquierda / Gauche / Left

● En Existencia / En stock / In Stock ○ Artículo sin Existencia / Indisponible en Stock / Non Stock Item
 Compatible con el Inserto SMTM. / Compatible avec SMTM Plaquettes. / Compatible with SMTM Insert.

Ejemplo de Pedido / Exemple de Commande / Ordering Example

1 Piezas / pcs. / pcs. ALKT-ZCC2-R-2525-35-45-3-T10



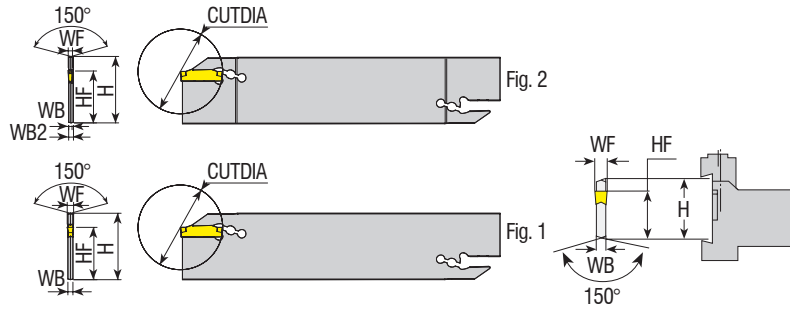

Código del Inserto Le Code de Commande Ordering Code	Stock Stock Stock	Dimension (mm) Dimension (mm) Dimension (mm)								Inserto Plaquette Insert	Recambios / Pièces de Rechange Spare Parts
		H	WF	WB2	WB	I	HF	CUTDIA	Fig.		Llaves Allen Clés Allen Allen Wrench
AKL-TD-32-2	●	32	2	2.4	1.6	150	25	39	2		ALA-02
AKL-TD-32-3	●	32	3	2.4	-	150	25	39	1		

Compatible con el Inserto TGTC. / Compatible avec TGTC Plaquettes. / Compatible with TGTC Insert.

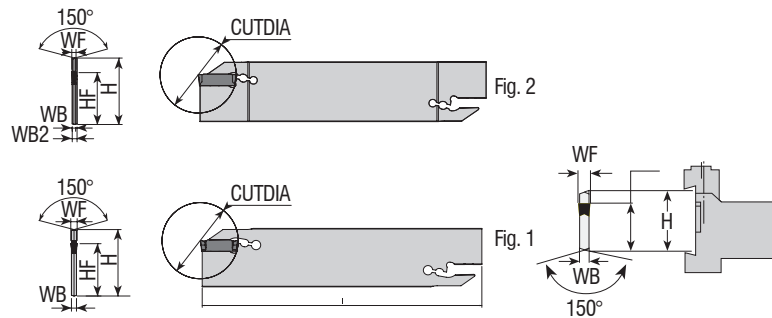

Código del Inserto Le Code de Commande Ordering Code	Stock Stock Stock	Dimension (mm) Dimension (mm) Dimension (mm)								Inserto Plaquette Insert	Recambios / Pièces de Rechange Spare Parts
		H	WF	WB2	WB	I	HF	CUTDIA	Fig.		Llaves Allen Clés Allen Allen Wrench
AKL-I-26-2	●	26	1.9-2.5	1.6	-	110	21.4	39	1		ALA-02
AKL-I-32-2	●	32	1.9-2.5	1.8	2.4	150	25	39	2		
AKL-I-26-3	●	26	3-3.18	2.4	-	110	21.4	39	1		
AKL-I-32-3	●	32	3-3.18	2.4	-	150	25	39	1		
AKL-I-26-4	●	26	4	3.2	-	110	21.4	80	1		
AKL-I-32-4	●	32	4	3.2	-	150	25	100	1		

R: Derecha / Droite / Right L: Izquierda / Gauche / Left

● En Existencia / En stock / In Stock ○ Artículo sin Existencia / Indisponible en Stock / Non Stock Item
Compatible con el Inserto ISCR. / Compatible avec ISCR Plaquettes. / Compatible with ISCR Insert.

Ejemplo de Pedido / Exemple de Commande / Ordering Example
1 Piezas / pcs. / pcs. AKL-TD-32-2

CORTADORES PARA TROZADO Y RANURADO PROFUNDO
LAMES DE TRANÇONNAGE ET RAINURAGE PROFOND
BLADES FOR PARTING AND DEEP GROOVING

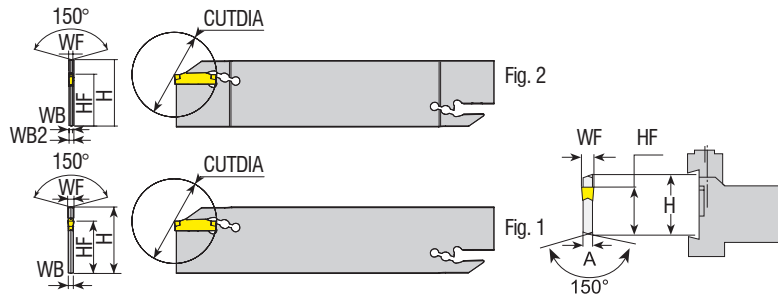

Código del Inserto Le Code de Commande Ordering Code	Stock Stock Stock	Dimension (mm) Dimension (mm) Dimension (mm)								Inserto Plaquette Insert	Recambios / Pièces de Rechange Spare Parts	
		H	WF	WB2	WB	I	HF	CUTDIA	Fig.		Liaves Allen Clés Allen Allen Wrench	
AKL-123-32-2	●	32	2	2.4	1.6	150	25	39	2			
AKL-123-32-3	●	32	3	2.4	-	150	25	39	1	123-3		
AKL-123-32-4	●	32	4	3.2	-	150	25	39	1	123-4		

Compatible con el Inserto SNDVK. / Compatible avec SNDVK Plaquettes. / Compatible with SNDVK Insert.

BLOQUE PARA TROZADO Y CORTADOR DE RANURADO PROFUNDO
BLOCS DE TRANÇONNAGE ET RAINURAGE PROFOND
BLOCKS FOR PARTING AND DEEP GROOVING BLADES

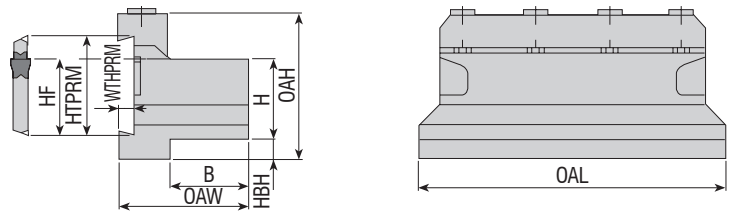

Código del Inserto Le Code de Commande Ordering Code	Stock Stock Stock	Dimension (mm) Dimension (mm) Dimension (mm)									Recambios / Pièces de Rechange / Spare Parts		
		HTPRM	HF	H	HBH	OAH	WTHPRM	OAL	B	OAW	Abrazadera Bride Wedge	Tornillo de Sujeción Vis de Fixation Wedge Screw	Liaves Allen Clés Allen Allen Wrench
ALBU-20-26	●	26	21.4	20	9	43	4	86	19	38		2505-M6x25	
ALBU-25-26	●	26	21.4	25	5	45	4	110	23	42	ABK-02		
ALBU-20-32	●	32	25	20	13	50	5.3	100	19	38	ABK-03	2505-M6x30	
ALBU-25-32	●	32	25	25	8	50	5.3	110	23	42	ABK-04		
ALBU-32-32	●	32	25	32	5	54	5.3	110	29	48			AAL-07-5

R: Derecha / Droite / Right L: Izquierda / Gauche / Left

● En Existencia / En stock / In Stock ○ Artículo sin Existencia / Indisponible en Stock / Non Stock Item

Ejemplo de Pedido / Exemple de Commande / Ordering Example

1 Piezas / pcs. / pcs. AKL-123-32-2



www.akko.com.tr

konusulan
the spoken kalite...
quality...



*konusulan
the spoken kalite...
quality...*

GROOVING

**PORTA HERRAMIENTAS DE RANURADO EXTERNO CON
AGUJERO REFRIGERANTE**

*PORTE-OUTILS DE RAINURAGE EXTERIEUR AVEC TROU D'ARROSAGE
PORTE-OUTILS À GORGE WITH COOLANT HOLES*



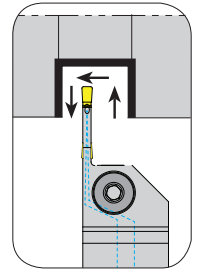
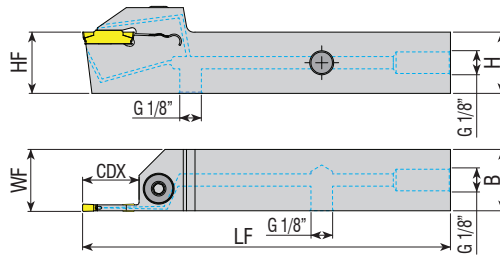

Código del Inserto
 Le Code de Commande
 Ordering Code

Stock Stock Stock		Dimension (mm) Dimension (mm) Dimension (mm)					Inserto Plaquette Insert	Recambios / Pièces de Rechange / Spare Parts					
R	L	HF=H	B	LF	WF	CDX		Tornillo Vis Screw	Arandela Timbre Washer	Llaves Allen Clés Allen Allen Wrench			
●	●	20	20	125	20.4	20	MGM. - 3						
ADKT-K-R/L-2020-3-T20-H													
●	●	25	25	150	25.4	22	MGM. - 4				2004-M8x1x20	-	AAL-05-4
ADKT-K-R/L-2525-3-T22-H													
●	●	20	20	125	20.4	20							
●	●	25	25	150	25.4	22	MGM. - 5						
ADKT-K-R/L-2020-4-T20-H													
ADKT-K-R/L-2525-4-T22-H													
ADKT-K-R/L-2525-5-T25-H													

Compatible con el Inserto KRLY. / Compatible avec KRLY Plaquettes. / Compatible with KRLY Insert.

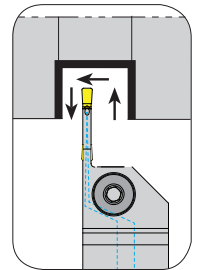
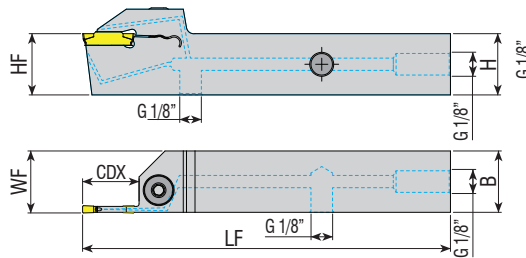

Código del Inserto
 Le Code de Commande
 Ordering Code

Stock Stock Stock		Dimension (mm) Dimension (mm) Dimension (mm)					Inserto Plaquette Insert	Recambios / Pièces de Rechange / Spare Parts		
R	L	HF=H	B	LF	WF	CDX		Tornillo Vis Screw	Arandela Timbre Washer	Llaves Allen Clés Allen Allen Wrench
●	●	20	20	125	20.5	30	TD. - 3			
ADKT-TD-R/L-2020-3-T30-H								2004-M8x1x20	-	AAL-05-4

R: Derecha / Droite / Right L: Izquierda / Gauche / Left

● En Existencia / En stock / In Stock ○ Artículo sin Existencia / Indisponible en Stock / Non Stock Item

Compatible con el Inserto TGTC. / Compatible avec TGTC Plaquettes. / Compatible with TGTC Insert.

Ejemplo de Pedido / Exemple de Commande / Ordering Example

1 Piezas / pcs. / pcs. ADKT-K-R-2020-3-T20-H

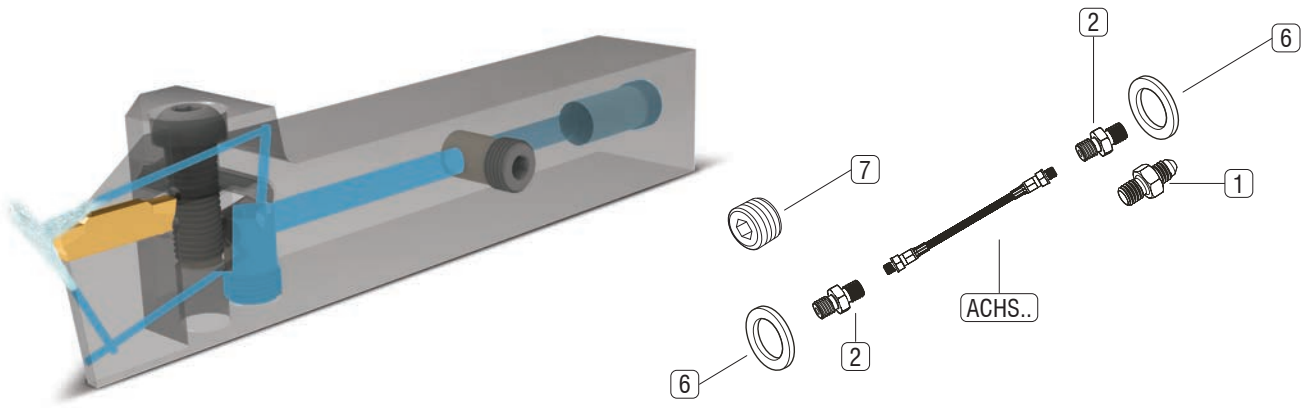

Nota: Se han diseñado 3 tipos de juegos de mangueras de refrigeración que se pueden utilizar en todos los tornos refrigerados internamente. Antes de usar las herramientas, se debe tener cuidado para asegurarse de que las conexiones no utilizadas estén cerradas con el tornillo en el juego y que el sellado esté asegurado. Los juegos de mangueras de refrigeración para herramientas de torno se pueden utilizar en el rango de presión de ACHS ... 10 bar hasta un máximo de 275 bar.

Note: 3 types d'ensembles de tuyaux de refroidissement sont conçus qui peuvent être utilisés dans tous les tours à refroidissement interne. Avant d'utiliser les outils, il faut veiller à ce que les connexions inutilisées sont fermées avec la vis dans l'ensemble et que l'étanchéité est assurée. ensembles de tuyaux de refroidissement pour tour d'outils peuvent être utilisés dans la plage de pression de CCSS ... 10 bar à la barre max 275.

Note: 3 types of cooling hose sets are designed that can be used in all internally cooled lathes. Before using the tools, care should be taken to ensure that the unused connections are closed with the screw in the set and that sealing is ensured. Cooling hose sets for lathe tools can be used in the pressure range of ACHS ... 10 bar to max 275 bar.

Partes En El Set Pièces Dans Le Jeu Parts In The Set				Código de Longitud / Code de Longueur / Length Code		
				Código del Set: Code de l'ensemble: Set Code: ACHS-1-250	Código del Set: Code de l'ensemble: Set Code: ACHS-2-250	Código del Set: Code de l'ensemble: Set Code: ACHS-3-250
	Imagen Image Picture	Código del Set Code de l'ensemble Set Code	Descripción del Producto Description du Produit Product Description			
1		AMP-01	Sujetador M10 M10 Fastener M10 Fastener	1x	-	-
2		AMP-02	Cierre Doble G 1/8 " G 1/8" Double Fastener G 1/8" Double Fastener	2x	1x	-
3		AMP-03	Angulo de Conexión G 1/8 " G 1/8" Connexion Angle G 1/8" Angle Connection	-	1x	2x
4		AMP-04	Angulo de Conexión M10" M10" Connexion Angle M10" Angle Connection	-	1x	1x
5		AMP-05	Pieza capilar G1 / 4 "-G1 / 8 " G1 / 4" -G1 / 8" Pièce Capillary G1 / 4"-G1/8" Capillary Piece	-	1x	1x
6		AG-01	Junta de Cobre Joint Cuivre Copper Gasket	2x	3x	4x
7		2705-G1/8-5.5	Perno de sellado G1 / 8 " G1 / 8" D'étanchéité Boulon G1/8" Sealing Bolt	1x	1x	1x
8		AH-1-250	Manguera Tuyau Hose	1x	-	-
9		AH-2-250	Manguera Tuyau Hose	-	1x	-
10		AH-3-250	Manguera Tuyau Hose	-	-	1x

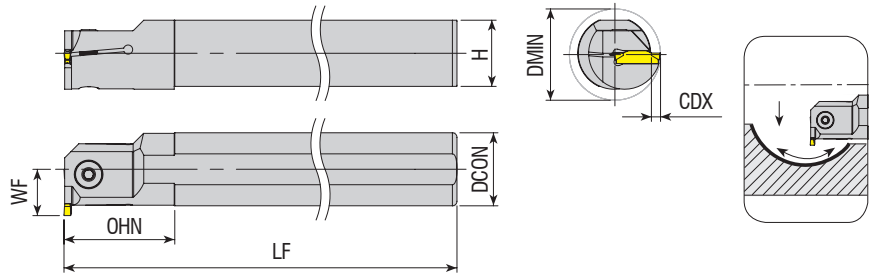

Código del Inserto
 Le Code de Commande
 Ordering Code

Código del Inserto Le Code de Commande Ordering Code	Stock Stock Stock		Dimension (mm) Dimension (mm) Dimension (mm)							Inserto Plaque Insert	Recambios / Pièces de Rechange / Spare Parts	
	R	L	DCON	DMIN	LF	OHN	CDX	H	WF		Tornillo Vis Screw	Llaves Allen Clés Allen Allen Wrench
AIKT-K-R/L-16-2-T4	●	●	16	21	150	28	4	14.8	12	MGM. - 2	2503-M4x10	AAL-03-3
AIKT-K-R/L-20-2-T4	●	●	20	25	170	30	4	18.3	14		2503-M4x12	
AIKT-K-R/L-25-2-T6	●	●	25	32	200	40	6	23	18.5		2504-M5x12	
AIKT-K-R/L-20-3-T6	●	●	20	27	170	30	6	18.3	16	MGM. - 3	2504-M5x12	AAL-05-4
AIKT-K-R/L-20-3-T7	●	●	20	25	170	38	7	18.3	13		2504-M5x16	
AIKT-K-R/L-25-3-T6	●	●	25	32	200	40	6	23	18.5		2504-M5x16	
AIKT-K-R/L-25-3-T10	●	●	25	32	200	48	10	23	17		2004-M8x1x20	
AIKT-K-R/L-32-3-T6	●	●	32	39	250	50	6	30	22		2504-M5x12	
AIKT-K-R/L-32-3-T12	●	●	32	39	250	53	12	30	22		2504-M5x16	
AIKT-K-R/L-40-3-T6	●	●	40	47	300	55	6	37.5	26		2004-M8x1x20	
AIKT-K-R/L-40-3-T12	●	○	40	48	300	63	12	37.5	27		2504-M5x12	
AIKT-K-R/L-20-4-T6	●	●	20	27	170	30	6	18.3	16		2504-M5x16	
AIKT-K-R/L-20-4-T7	●	○	20	25	170	38	7	18.3	13		2504-M5x16	
AIKT-K-R/L-25-4-T6	●	●	25	32	200	40	6	23	18.5	MGM. - 4	2004-M8x1x20	
AIKT-K-R/L-25-4-T10	●	●	25	32	200	49	10	23	17			
AIKT-K-R/L-32-4-T6	●	●	32	39	250	50	6	30	22			
AIKT-K-R/L-32-4-T12	●	●	32	39	250	53	12	30	22			
AIKT-K-R/L-40-4-T6	●	●	40	47	300	55	6	37.5	26			
AIKT-K-R/L-40-4-T12	●	●	40	48	300	63	12	37.5	27	MGM. - 5	2504-M5x16	
AIKT-K-R/L-25-5-T7	●	●	25	33	200	40	7	23	19.5			
AIKT-K-R/L-32-5-T7	●	●	32	40	250	50	7	30	23			2004-M8x1x20
AIKT-K-R/L-40-5-T7	●	●	40	48	300	55	7	37.5	27			
AIKT-K-R/L-40-5-T12	●	○	40	48	300	63	12	37.5	27			

R: Derecha / Droite / Right L: Izquierda / Gauche / Left
 ● En Existencia / En stock / In Stock ○ Artículo sin Existencia / Indisponible en Stock / Non Stock Item
 Compatible con el Inserto KRLY. / Compatible avec KRLY Plaquettes. / Compatible with KRLY Insert.

Ejemplo de Pedido / Exemple de Commande / Ordering Example
 1 Piezas / pcs. / pcs. AIKT-K-R-16-2-T4

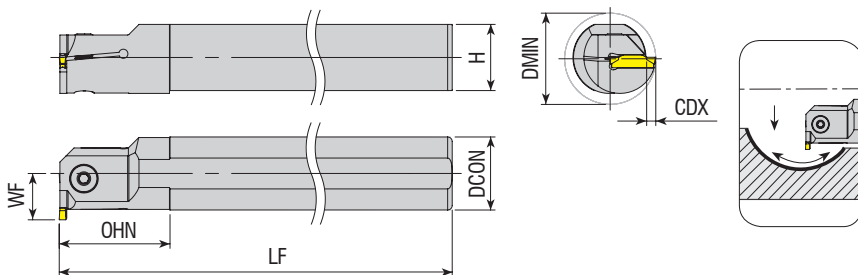

Código del Inserto Le Code de Commande Ordering Code	Stock Stock		Dimension (mm) Dimension (mm) Dimension (mm)							Inserto Plaquette Insert	Recambios / Pièces de Rechange / Spare Parts	
	R	L	DCON	DMIN	LF	OHN	CDX	H	WF		Tornillo Vis Screw	Llaves Allen Clés Allen Allen Wrench
AIKT-KG-R/L-25-2-T7	●	●	25	33	200	40	7	23	19.5	KG.. - 2	2504-M5x12	AAL-05-4
AIKT-KG-R/L-20-3-T6.5-H	●	○	20	27.5	170	30	6.5	18.3	16.5		2504-M5x16	
AIKT-KG-R/L-25-3-T7	○	○	25	33	200	40	7	23	19.5	2004-M8x1x20		
AIKT-KG-R/L-40-3-T8	●	○	40	50	300	55	8	37.5	28	2504-M5x16		
AIKT-KG-R/L-25-4-T8	●	●	25	34	200	40	8	23	20.5	KG.. - 4	2504-M5x16	

Compatible con el Inserto KRLY. / Compatible avec KRLY Plaquettes. / Compatible with KRLY Insert.

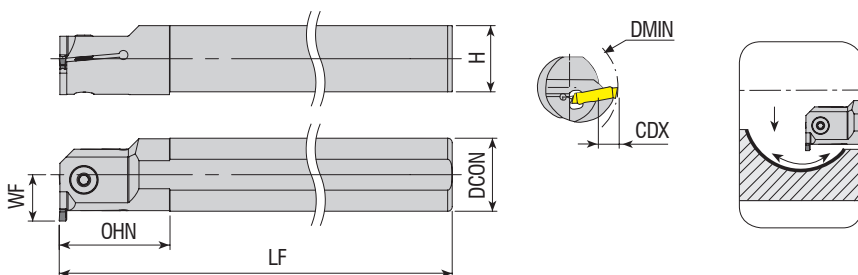

Código del Inserto Le Code de Commande Ordering Code	Stock Stock		Dimension (mm) Dimension (mm) Dimension (mm)							Inserto Plaquette Insert	Recambios / Pièces de Rechange / Spare Parts	
	R	L	DCON	DMIN	LF	OHN	CDX	H	WF		Tornillo Vis Screw	Llaves Allen Clés Allen Allen Wrench
AIKT-H-R/L-25-3-T8	●	●	25	34	200	40	8	23	20.5	S229 - 3	2504-M5x16	AAL-05-4
AIKT-H-R/L-32-3-T7	●	●	32	40	250	50	7	30	23		2004-M8x1x20	
AIKT-H-R/L-40-3-T7	●	●	40	48	300	55	7	37.5	27		2504-M5x16	
AIKT-H-R/L-25-4-T8	●	●	25	34	200	40	8	23	20.5	S229 - 4	2504-M5x16	
AIKT-H-R/L-32-4-T7	●	●	32	40	250	50	7	30	23		2004-M8x1x20	
AIKT-H-R/L-40-4-T7	●	●	40	48	300	55	7	37.5	27	2504-M5x16		
AIKT-H-R/L-25-5-T8	●	●	25	34	200	40	8	23	20.5	S229 - 5	2504-M5x16	
AIKT-H-R/L-32-5-T7	●	○	32	40	250	50	7	30	23		2004-M8x1x20	
AIKT-H-R/L-40-5-T7	●	○	40	48	300	55	7	37.5	27		2004-M8x1x20	

R: Derecha / Droite / Right L: Izquierda / Gauche / Left

● En Existencia / En stock / In Stock ○ Artículo sin Existencia / Indisponible en Stock / Non Stock Item

Compatible con el Inserto HRN. / Compatible avec HRN Plaquettes. / Compatible with HRN Insert.

Ejemplo de Pedido / Exemple de Commande / Ordering Example

1 Piezas / pcs. / pcs. AIKT-KG-R-25-2-T7

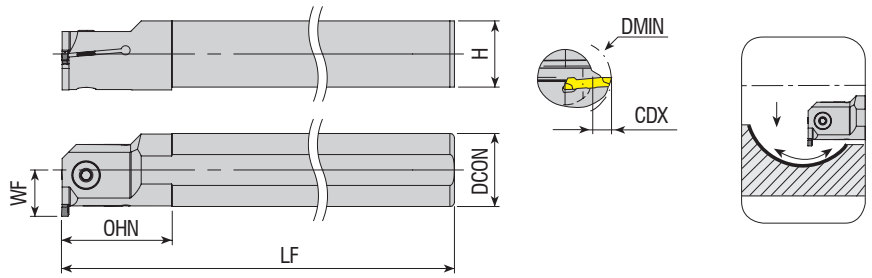

Código del Inserto Le Code de Commande Ordering Code	Stock Stock		Dimension (mm) Dimension (mm) Dimension (mm)							Inserto Plaque Insert	Recambios / Pièces de Rechange / Spare Parts	
	R	L	DCON	DMIN	LF	OHN	CDX	H	WF		Tornillo Vis Screw	Llaves Allen Clés Allen Allen Wrench
AIKT-HK-R/L-20-2-T6	●	●	20	26	170	30	6	18.3	16	S224 - 2	2503-M4x12	AAL-03-3
AIKT-HK-R/L-25-2-T6	●	○	25	32	200	40	6	23	18.5		2504-M5x16	
AIKT-HK-R/L-20-3-T6	●	○	20	27	170	30	6	18.3	16	S224 - 3	2504-M5x12	AAL-05-4
AIKT-HK-R/L-25-3-T6	●	●	25	32	200	40	6	23	18.5		2504-M5x16	
AIKT-HK-R/L-32-3-T6	●	●	32	39	250	50	6	30	22	S224 - 4	2004-M8x1x20	AAL-05-4
AIKT-HK-R/L-20-4-T6	●	○	20	27	170	30	6	18.3	16		2504-M5x12	
AIKT-HK-R/L-25-4-T6	●	○	25	32	200	40	6	23	18.5	2504-M5x16	2004-M8x1x20	
AIKT-HK-R/L-32-4-T6	●	○	32	39	250	50	6	30	22			
AIKT-HS223-R/L-20-2-T5	●	○	20	26	170	33	5	18.3	15	S223 - 2	2503-M4x12	AAL-03-3
AIKT-HS223-R/L-25-2-T5	●	○	25	31	200	40	5	23	17.5		2504-M5x16	
AIKT-HS223-R/L-20-3-T6	●	○	20	27	170	33	6	18.3	16	S223 - 3	2504-M5x12	AAL-05-4
AIKT-HS223-R/L-25-3-T6	●	○	25	32	200	40	6	23	18.5		2504-M5x16	

Compatible con el Inserto HRN. / Compatible avec HRN Plaquettes. / Compatible with HRN Insert.

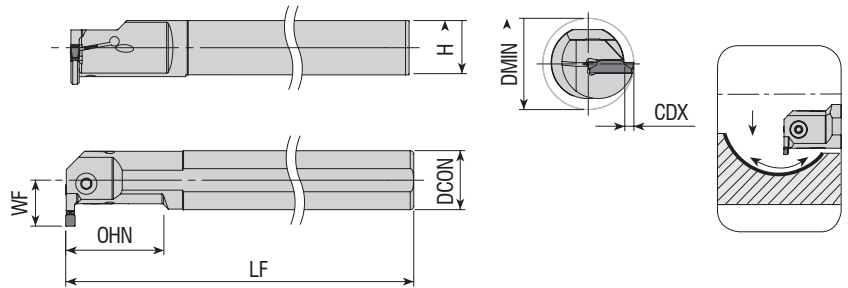

Código del Inserto Le Code de Commande Ordering Code	Stock Stock		Dimension (mm) Dimension (mm) Dimension (mm)							Inserto Plaque Insert	Recambios / Pièces de Rechange / Spare Parts	
	R	L	DCON	DMIN	LF	OHN	CDX	H	WF		Tornillo Vis Screw	Llaves Allen Clés Allen Allen Wrench
AIKT-KM-R/L-20-2-T7	●	●	20	25	170	40	7	18.3	13	A4. - 2	2503-M4x12	AAL-03-3
AIKT-KM-R/L-20-3-T7	●	○	20	25	170	40	7	18.3	13		2504-M5x12	AAL-05-4
AIKT-KM-R/L-25-3-T10	●	●	25	32	200	50	10	23	17	A4. - 3	2505-M6x16	AAL-07-5
AIKT-KM-R/L-32-3-T12	●	●	32	40	250	64	12	30	22		2505-M6x20	
AIKT-KM-R/L-40-3-T12	●	●	40	48	300	80	12	37.5	27	A4. - 4	2504-M5x12	AAL-05-4
AIKT-KM-R/L-20-4-T7	●	○	20	25	170	40	7	18.3	13		2504-M5x14	
AIKT-KM-R/L-32-4-T12.2-H	●	○	32	40	190	104	12.2	31	22			

R: Derecha / Droite / Right L: Izquierda / Gauche / Left

● En Existencia / En stock / In Stock ○ Artículo sin Existencia / Indisponible en Stock / Non Stock Item

Compatible con el Inserto KNMTL. / Compatible avec KNMTL Plaquettes. / Compatible with KNMTL Insert.

Ejemplo de Pedido / Exemple de Commande / Ordering Example

1 Piezas / pcs. / pcs. AIKT-HK-R-20-2-T6

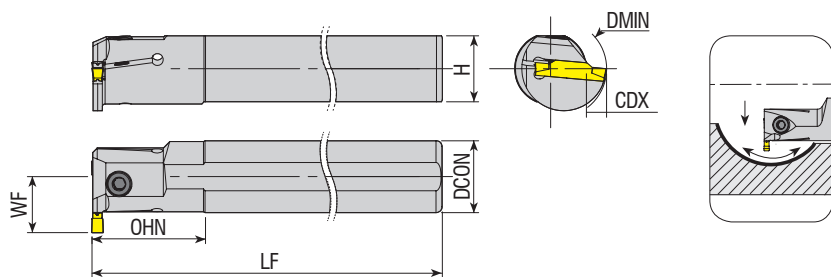

Código del Inserto Le Code de Commande Ordering Code	Stock Stock Stock		Dimension (mm) Dimension (mm) Dimension (mm)							Inserto Plaquette Insert	Recambios / Pièces de Rechange / Spare Parts			
	R	L	DCON	DMIN	LF	OHN	CDX	H	WF		Tornillo Vis Screw	Llaves Allen Clés Allen Allen Wrench		
AIKT-123-R/L-20-2-T6	●	○	20	32	170	30	6	18.3	16	123 - 2			AAL-03-3	
AIKT-123-R/L-25-2-T6	●	○	25	32	200	40	6	18.3	18.5					2504-M5x12
AIKT-123-R/L-32-2-T7	●	○	32	41	250	45	7	30	23					2004-M8x1x20
AIKT-123-R/L-20-3-T6	●	○	20	32	170	30	6	18.3	16	123 - 3			AAL-05-4	
AIKT-123-R/L-25-3-T7	●	○	25	32	200	40	7	23	19.5					2004-M8x1x20
AIKT-123-R/L-32-3-T9	●	○	32	41	250	50	9	30	25					2504-M5x16
AIKT-123-R/L-20-4-T8	●	○	20	29	170	30	8	18.3	18	123 - 4			AAL-05-4	
AIKT-123-R/L-25-4-T7	●	○	25	32	200	40	7	23	19.5					2004-M8x1x20
AIKT-123-R/L-32-4-T7	●	●	32	41	250	45	7	30	23					2504-M5x16
AIKT-123-R/L-32-4-T10	●	○	32	43	250	50	10	30	26	123 - 5			AAL-05-4	
AIKT-123-R/L-25-5-T8	●	○	25	34	200	40	8	23	20.5					2004-M8x1x20
AIKT-123-R/L-32-5-T11	●	●	32	43	250	50	11	30	27					2504-M5x16

Compatible con el Inserto SNDVK. / Compatible avec SNDVK Plaqueettes. / Compatible with SNDVK Insert.

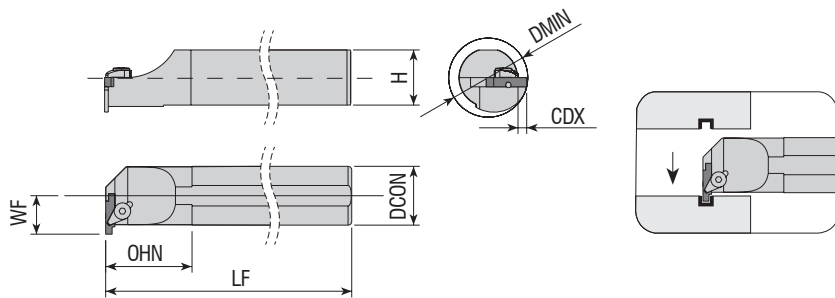

Código del Inserto Le Code de Commande Ordering Code	Stock Stock Stock		Dimension (mm) Dimension (mm) Dimension (mm)							Inserto Plaquette Insert	Recambios / Pièces de Rechange / Spare Parts					
	R	L	DCON	DMIN	LF	OHN	CDX	H	WF		Abrazadera de Cuñas Mode de Fixation Wedge Clamp	Tornillo Vis Screw	Pin Épingle Pin	Llaves Allen Clés Allen Allen Wrench		
AIKT-154.91-R/L-16-3-T3	●	●	16	20	150	35	3	14.8	11	154.91 - 3				APM-06	AAL-05-4	
AIKT-154.91-R/L-20-3-T4	●	●	20	25	170	38	4	18.3	14							AKV-21-M6x18
AIKT-154.91-R/L-25-3-T4	●	●	25	31	200	40	4	23	16.5							AKV-07-M6x22
AIKT-154.91-R/L-25-5-T5	●	●	25	31	200	45	5	23	17.5	154.91 - 5			APM-06	AAL-03-3		
AIKT-154.91-R/L-32-5-T5	●	●	32	38	250	50	5	30	21							

R: Derecha / Droite / Right L: Izquierda / Gauche / Left

● En Existencia / En stock / In Stock ○ Artículo sin Existencia / Indisponible en Stock / Non Stock Item

Compatible con el Inserto SNDVK. / Compatible avec SNDVK Plaqueettes. / Compatible with SNDVK Insert.

Ejemplo de Pedido / Exemple de Commande / Ordering Example

1 Piezas / pcs. / pcs. AIKT-123-R-20-2-T6

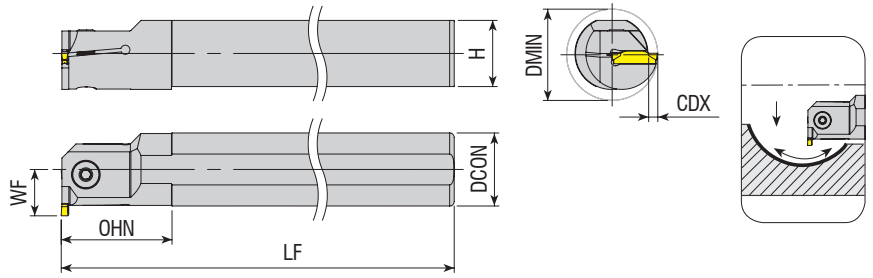

Código del Inserto Le Code de Commande Ordering Code	Stock Stock		Dimension (mm) Dimension (mm) Dimension (mm)							Inserto Plaquette Insert	Recambios / Pièces de Rechange / Spare Parts	
	R	L	DCON	DMIN	LF	OHN	CDX	H	WF		Tornillo Vis Screw	Llaves Allen Clés Allen Allen Wrench
AIKT-RD-R/L-16-2-T6	●	○	16	24	150	28	6	14.8	14	RD. - 2	2503-M4x10	AAL-03-3
AIKT-RD-R/L-20-2-T6	●	○	20	28	170	28	6	18.3	16			
AIKT-RD-R/L-25-2-T6	●	○	25	33	200	28	6	23	18.5			
AIKT-RD-R/L-16-3-T6	●	○	16	24	150	28	6	14.8	14	RD. - 3	2503-M4x10	AAL-05-4
AIKT-RD-R/L-20-3-T6	●	○	20	28	170	28	6	18.3	16			
AIKT-RD-R/L-25-3-T6	●	○	25	33	200	28	6	23	18.5			
AIKT-RD-R/L-32-3-T6	●	○	32	40	250	50	6	30	22	RD. - 4	2004-M8x1x20	
AIKT-RD-R/L-20-4-T6	●	○	20	28	170	28	6	18.3	16			
AIKT-RD-R/L-25-4-T6	●	○	25	33	200	28	6	23	18.5			
AIKT-RD-R/L-32-4-T6	●	○	32	40	250	50	6	30	22			

Compatible con el Inserto TGTC. / Compatible avec TGTC Plaquettes. / Compatible with TGTC Insert.

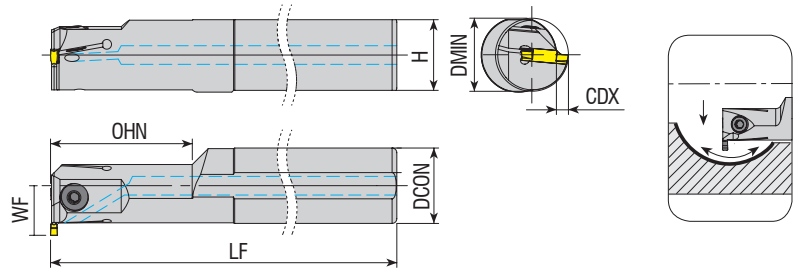

Código del Inserto Le Code de Commande Ordering Code	Stock Stock		Dimension (mm) Dimension (mm) Dimension (mm)							Inserto Plaquette Insert	Recambios / Pièces de Rechange / Spare Parts	
	R	L	DCON	DMIN	LF	OHN	CDX	H	WF		Tornillo Vis Screw	Llaves Allen Clés Allen Allen Wrench
AIKT-TD-R/L-16-2-T8.5-H	●	○	16	25	150	28	8.5	14.8	16.5	TD. - 2	2503-M4x10	AAL-03-3
AIKT-TD-R/L-20-3-T6-H	●	○	20	25	170	40	6	18.3	16	TD. - 3	2504-M5x12	AAL-05-4
AIKT-TD-R/L-25-3-T6-H	●	○	25	25	200	40	6	23	18.5		2504-M5x16	
AIKT-TD-R/L-32-3-T5-H	●	○	32	31	250	60	5	30	21		2004-M8x1x20	

R: Derecha / Droite / Right L: Izquierda / Gauche / Left

● En Existencia / En stock / In Stock ○ Artículo sin Existencia / Indisponible en Stock / Non Stock Item
 Compatible con el Inserto TGTC. / Compatible avec TGTC Plaquettes. / Compatible with TGTC Insert.

Ejemplo de Pedido / Exemple de Commande / Ordering Example
 1 Piezas / pcs. / pcs. AIKT-RD-R-16-2-T6

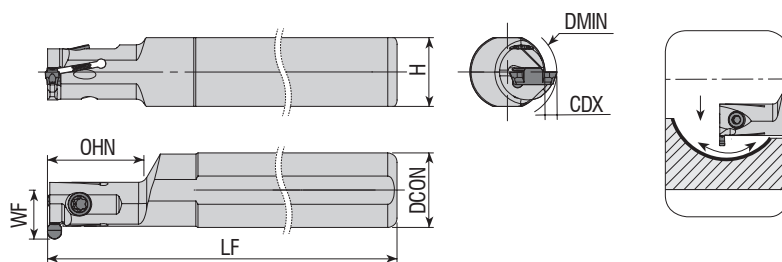

Código del Inserto Le Code de Commande Ordering Code	Stock Stock Stock		Dimension (mm) Dimension (mm) Dimension (mm)							Inserto Plaquette Insert	Recambios / Pièces de Rechange / Spare Parts	
	R	L	DCON	DMIN	LF	OHN	CDX	H	WF		Tornillo Vis Screw	Llave Torx Clé Torx Torx Wrench
AIKT-IGE-R/L-10-2-T3-H	●	○	10	11.5	125	25	3	9	8.3	GEPI - 2	3008-M3x8	80-T08
AIKT-IGE-R/L-16-2-T3-D11.5	●	○	16	11.5	125	20	3	14.8	11.1			
AIKT-IGE-R/L-16-2-T2.5-H	●	●	16	13	125	20	2.5	14.8	10.5	GEPI - 3	1315-M4x11	80-T15
AIKT-IGE-R/L-16-3-T2.5-H	●	○	16	13	125	20	2.5	14.8	10.5			
AIKT-IGE-R/L-16-3-T2.5-D20	●	○	16	20	125	28	2.5	14.8	10.5			

Compatible con el Inserto ISCR. / Compatible avec ISCR Plaquettes. / Compatible with ISCR Insert.

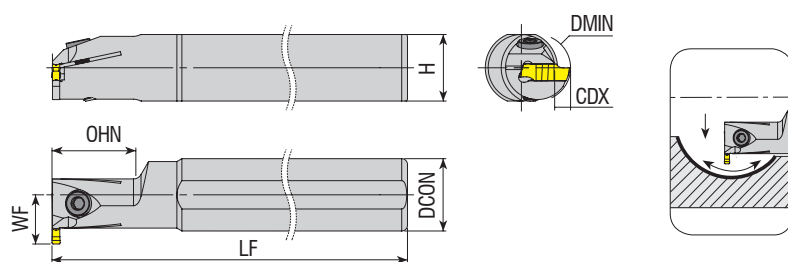

Código del Inserto Le Code de Commande Ordering Code	Stock Stock Stock		Dimension (mm) Dimension (mm) Dimension (mm)							Inserto Plaquette Insert	Recambios / Pièces de Rechange / Spare Parts		
	R	L	DCON	DMIN	LF	OHN	CDX	H	WF		Tornillo Vis Screw	Llave Torx Clé Torx Torx Wrench	Llaves Allen Clés Allen Allen Wrench
AIKT-IGI-R/L-20-3-T4	●	●	20	20	170	25	4	18.3	14.5	GIMIY / GIPI - 3	1020-M5x14	80-T20	
AIKT-IGI-R/L-25-3-T5	●	●	25	23	200	30	5	23	17		2504-M5x16		
AIKT-IGI-R/L-32-3-T5	●	●	32	31	250	30	5	30	21		2004-M8x1x20		AAL-05-4
AIKT-IGI-R/L-40-3-T5	●	○	40	50	300	50	5	37.5	25	GIMIY / GIPI - 4	1020-M5x14	80-T20	
AIKT-IGI-R/L-20-4-T4	●	●	20	20	170	25	4	18.3	14.5		GIMIY / GIPI - 5	2504-M5x16	AAL-05-4
AIKT-IGI-R/L-25-5-T10	●	○	25	32	200	25	10	23	22.5				
AIKT-IGI-R/L-25-5-T15	●	○	25	37	200	25	15	23	27.5				

R: Derecha / Droite / Right L: Izquierda / Gauche / Left
 ● En Existencia / En stock / In Stock ○ Artículo sin Existencia / Indisponible en Stock / Non Stock Item
 Compatible con el Inserto ISCR. / Compatible avec ISCR Plaquettes. / Compatible with ISCR Insert.

Ejemplo de Pedido / Exemple de Commande / Ordering Example
 1 Piezas / pcs. / pcs. AIKT-IGE-R-10-2-T3-H

Nota: Las longitudes de "OHN" se dan acorde a el diámetro D mínimo.
 Note: Longueurs de "OHN" sont donnés en fonction du diamètre D min.
 Note: Lengths of "OHN" are given according to D min diameter.

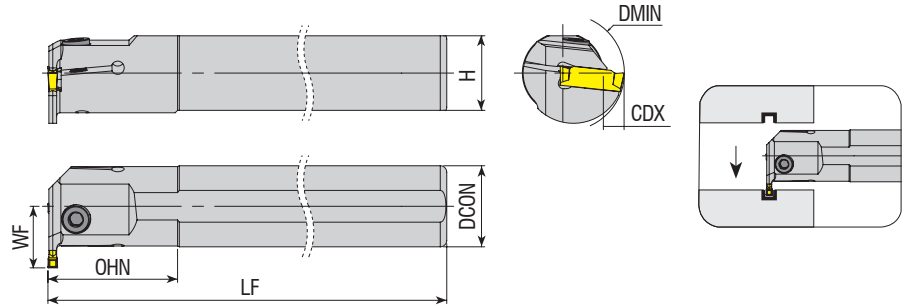

Código del Inserto
 Le Code de Commande
 Ordering Code

Stock Stock Stock	Dimension (mm) Dimension (mm) Dimension (mm)									Inserto Plaquette Insert	Recambios / Pièces de Rechange / Spare Parts	
	R	L	DCON	DMIN	LF	OHN	CDX	H	WF		Tornillo Vis Screw	Llaves Allen Clés Allen Allen Wrench
AIKT-I-R/L-20-3-T5	●	●	20	26	170	25	5	18.3	15.5	DGN - 3	2504-M5x12	AAL-05-4
AIKT-I-R/L-25-3-T6	●	●	25	32	200	40	6	23	19		2504-M5x16	

Compatible con el Inserto ISCR. / Compatible avec ISCR Plaquettes. / Compatible with ISCR Insert.

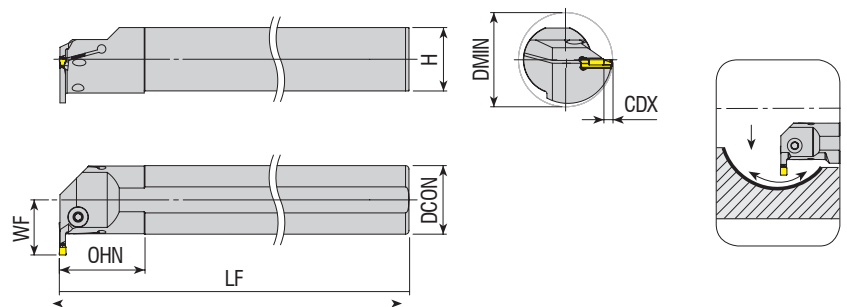

Código del Inserto
 Le Code de Commande
 Ordering Code

Stock Stock Stock	Dimension (mm) Dimension (mm) Dimension (mm)									Inserto Plaquette Insert	Recambios / Pièces de Rechange / Spare Parts	
	R	L	DCON	DMIN	LF	OHN	CDX	H	WF		Tornillo Vis Screw	Llaves Allen Clés Allen Allen Wrench
AIKT-IG-R/L-25-4-T10-H	●	●	25	36	200	40	10	23	22.7	DGN / GRP - 4	2504-M5X16	AAL-05-4
AIKT-IG-R/L-32-4-T10-H	●	●	32	43	250	45	10	30	26.2		2004-M8x1x20	
AIKT-IG-R/L-40-4-T12-H	●	●	40	53	250	50	12	37.5	32.2			
AIKT-IG-R/L-25-5-T10-H	●	○	25	36	200	40	10	23	22.7	DGN / GRP - 5	2504-M5X16	
AIKT-IG-R/L-32-5-T10-H	●	○	32	43	250	45	10	30	26.2		2004-M8x1x20	
AIKT-IG-R/L-40-5-T12-H	●	○	40	53	250	50	12	37.5	32.2			
AIKT-IG-R/L-50-5-T12-H	●	○	50	63	300	60	12	47	37.2			

R: Derecha / Droite / Right L: Izquierda / Gauche / Left

● En Existencia / En stock / In Stock ○ Artículo sin Existencia / Indisponible en Stock / Non Stock Item

Compatible con el Inserto ISCR. / Compatible avec ISCR Plaquettes. / Compatible with ISCR Insert.

Ejemplo de Pedido / Exemple de Commande / Ordering Example

1 Piezas / pcs. / pcs. AIKT-I-R-20-3-T5

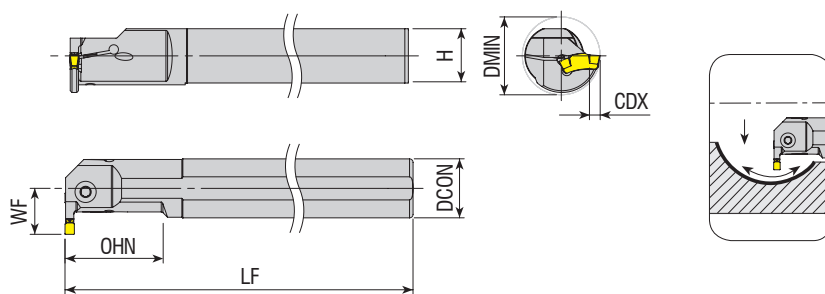

Código del Inserto Le Code de Commande Ordering Code	Stock		Dimension (mm) Dimension (mm) Dimension (mm)							Inserto Plaquette Insert	Recambios / Pièces de Rechange / Spare Parts		
	R	L	DCON	DMIN	LF	OHN	CDX	H	WF		Tornillo Vis Screw	Llave Torx Clé Torx Torx Wrench	Llaves Allen Clés Allen Allen Wrench
AIKT-ITG-R/L-16-3-T6-H	●	●	16	20	150	25	6	14.8	12	TGM. - 3		80-T20	
AIKT-ITG-R/L-20-3-T6-H	●	●	20	25	170	32	6	18.3	14.2				
AIKT-ITG-R/L-25-3-T8-H	●	●	25	32	200	40	8	23	18.8				
AIKT-ITG-R/L-32-3-T8-H	●	●	32	38	250	49	8	30	22				
AIKT-ITG-R/L-20-4-T6-H	●	●	20	25	170	33	6	18.3	14.2	TGM. - 4		80-T20	
AIKT-ITG-R/L-25-4-T7-H	●	●	25	31	200	41	7	23	17.5				
AIKT-ITG-R/L-25-4-T9-H	●	●	25	32.5	200	41	9	23	19.5				
AIKT-ITG-R/L-32-4-T11-H	●	●	32	42	250	50	11	30	25.5				
AIKT-ITG-R/L-40-4-T11-H	●	●	40	53	300	50	11	37.5	32	TGM. - 6.35		AAL-05-4	
AIKT-ITG-R/L-32-6.35-T17.5-H	●	●	32	57	250	50	17.5	30	29				

Compatible con el Inserto ISCR. / Compatible avec ISCR Plaquettes. / Compatible with ISCR Insert.

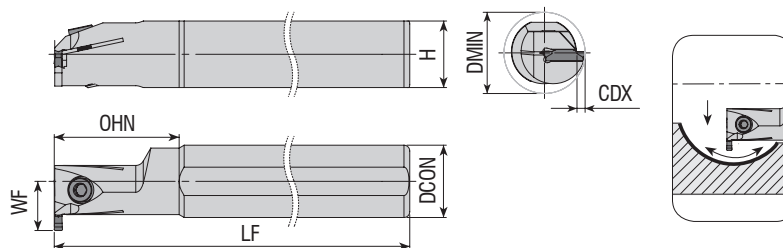

Código del Inserto Le Code de Commande Ordering Code	Stock		Dimension (mm) Dimension (mm) Dimension (mm)							Inserto Plaquette Insert	Recambios / Pièces de Rechange / Spare Parts	
	R	L	DCON	DMIN	LF	OHN	CDX	H	WF		Tornillo Vis Screw	Llaves Allen Clés Allen Allen Wrench
AIKT-GP-R/L-20-2-T4	●	○	20	25	170	30	4	18.3	14.5	GP - 2		AAL-03-3
AIKT-GP-R/L-25-2-T6	●	○	25	32	200	40	6	23	18.5			
AIKT-GP-R/L-20-3-T6	●	○	20	27	170	30	6	18.3	16	GP - 3		AAL-05-4
AIKT-GP-R/L-25-3-T6	●	○	25	32	200	40	6	23	18.5			
AIKT-GP-R/L-32-3-T6	●	○	32	39	250	50	6	30	22			
AIKT-GP-R/L-20-4-T6	●	○	20	27	170	30	6	18.3	16	GP - 4		AAL-05-4
AIKT-GP-R/L-25-4-T6	●	○	25	32	200	40	6	23	18.5			
AIKT-GP-R/L-32-4-T6	●	○	32	39	250	50	6	30	22			

R: Derecha / Droite / Right L: Izquierda / Gauche / Left

● En Existencia / En stock / In Stock ○ Artículo sin Existencia / Indisponible en Stock / Non Stock Item

Compatible con el Inserto PLBT. / Compatible avec PLBT Plaquettes. / Compatible with PLBT Insert.

Ejemplo de Pedido / Exemple de Commande / Ordering Example

1 Piezas / pcs. / pcs. AIKT-ITG-R-16-3-T6-H

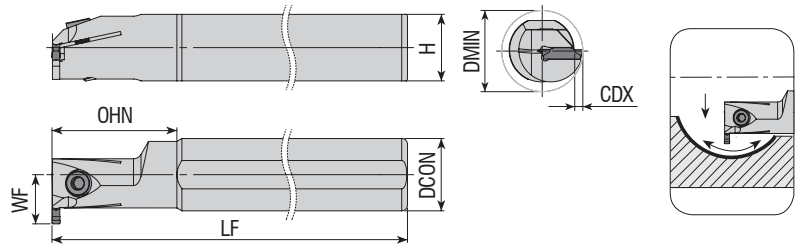

Código del Inserto
 Le Code de Commande
 Ordering Code

Código del Inserto Le Code de Commande Ordering Code	Stock Stock Stock		Dimension (mm) Dimension (mm) Dimension (mm)							Inserto Plaquette Insert	Recambios / Pièces de Rechange / Spare Parts		
	R	L	DCON	DMIN	LF	OHN	CDX	H	WF		Tornillo Vis Screw	Llave Torx Clé Torx Torx Wrench	
AIKT-TG-R/L-20-2-T6	●	○	20	28	160	28	6	18.3	15.8	DGM2-020	2503-M4x10	AAL-03-3	
AIKT-TG-R/L-20-3-T6	●	○	20	28	160	28	6	18.3	15.8		2504-M5x12		
AIKT-TG-R/L-25-3-T8	●	○	25	35	200	28	8	23	21.5	DTX3-030	2504-M5x16	AAL-05-4	
AIKT-TG-R/L-32-3-T10	●	○	32	43	250	50	10	30	27		2004-M8x1x20		
AIKT-TG-R/L-32-3-T12	●	○	32	45	250	50	12	30	27				
AIKT-TG-R/L-32-4-T10	●	○	32	43	250	50	10	30	27	DTX4-040			
AIKT-TG-R/L-32-5-T10	●	○	32	43	250	50	10	30	27	DTX5-040			

Compatible con el Inserto TNGLY. / Compatible avec TNGLY Plaquettes. / Compatible with TNGLY Insert.

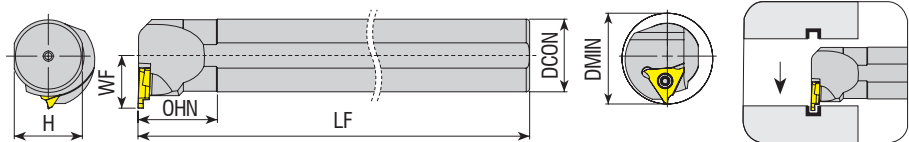

Código del Inserto
 Le Code de Commande
 Ordering Code

Código del Inserto Le Code de Commande Ordering Code	Stock Stock Stock		Dimension (mm) Dimension (mm) Dimension (mm)							Inserto Plaquette Insert	Recambios / Pièces de Rechange / Spare Parts		
	R	L	DCON	DMIN	LF	OHN	CDX	H	WF		Tornillo Vis Screw	Llave Torx Clé Torx Torx Wrench	
AIKT-QC11-R/L-20-(0.5-1.8)	●	○	20	16	150	40	-	18.3	12	QC11R/L (0.50-1.80)	3008 M2.5x6	80-T08	
AIKT-QC16-R/L-20-(0.5-1.8)	○	○	20	25	150	35	-	18.3	13.5	QC16R/L (0.50-1.80)	4015-M3.5x10	80-T15	
AIKT-QC16-R/L-20-(0.5-2.5)	●	○	20	25	150	35	-	18.3	13.5	QC16R/L (0.50-2.50)			
AIKT-QC22-R/L-25-(1-2.3)	○	○	25	35	150	35	-	23	18.2	QC22R/L (1.00-2.30)	1020 M5x11	80-T20	
AIKT-QC22-R/L-25-(2.5-3.3)	●	○	25	35	150	35	-	23	18.2	QC22R/L (2.50-3.30)			
AIKT-QC22-R/L-25-(3.3-4.8)	●	○	25	35	150	35	-	23	18.2	QC22R/L (3.30-4.80)			
AIKT-QC22-R/L-32-(1-2.3)	○	○	32	45	150	35	-	30	23.2	QC22R/L (1.00-2.30)			

R: Derecha / Droite / Right L: Izquierda / Gauche / Left

● En Existencia / En stock / In Stock ○ Artículo sin Existencia / Indisponible en Stock / Non Stock Item

Compatible con el Inserto ZCC. / Compatible avec ZCC Plaquettes. / Compatible with ZCC Insert.

Ejemplo de Pedido / Exemple de Commande / Ordering Example

1 Piezas / pcs. / pcs. AIKT-TG-R-20-2-T6

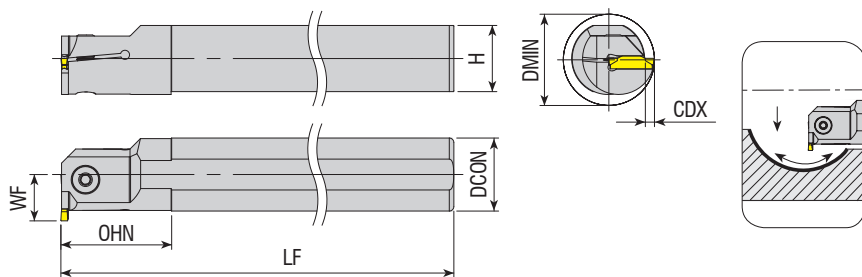

Código del Inserto Le Code de Commande Ordering Code	Stock		Dimension (mm) Dimension (mm) Dimension (mm)							Inserto Plaquette Insert	Recambios / Pièces de Rechange / Spare Parts	
	R	L	DCON	DMIN	LF	OHN	CDX	H	WF		Tornillo Vis Screw	Llaves Allen Clés Allen Allen Wrench
AIKT-ZCC2-R/L-16-2-T4	●	○	16	21	150	28	4	14.8	12	Z.BD - 2	2503-M4x10	AAL-03-3
AIKT-ZCC2-R/L-20-3-T5	●	●	20	27	170	30	5	18.3	15			
AIKT-ZCC2-R/L-20-3-T8	●	○	20	29	170	30	8	18.3	18	Z.FD - 3	2504-M5x12 2504-M5x16 2004-M8x1x20	AAL-05-4
AIKT-ZCC2-R/L-25-3-T5	●	○	25	31	200	40	5	23	17.5			
AIKT-ZCC2-R/L-25-3-T10	●	○	25	36	200	40	10	23	22.5			
AIKT-ZCC2-R/L-32-3-T6	●	○	32	39	250	50	6	30	22			
AIKT-ZCC2-R/L-32-3-T8	●	○	32	41	250	50	8	30	24			
AIKT-ZCC2-R/L-32-3-T13	●	○	32	46	250	50	13	30	29	Z.GD - 4	2504-M5x12 2504-M5x16	AAL-05-4
AIKT-ZCC2-R/L-40-3-T12	●	○	40	53	300	55	12	37.5	32			
AIKT-ZCC2-R/L-25-4-T6	●	○	25	32	200	40	6	23	18.5	Z.HD - 5	2004-M8x1x20	
AIKT-ZCC2-R/L-32-4-T7	●	○	32	40	250	50	7	30	23			
AIKT-ZCC2-R/L-32-4-T8	●	○	32	41	250	50	8	30	24			
AIKT-ZCC2-R/L-32-4-T10	●	○	32	43	250	50	10	30	26			
AIKT-ZCC2-R/L-32-5-T7	●	○	32	40	250	50	7	30	23			
AIKT-ZCC2-R/L-32-5-T8	●	○	32	41	250	50	8	30	24			
AIKT-ZCC2-R/L-40-5-T8	●	○	40	49	300	55	8	37.5	28			
AIKT-ZCC2-R/L-40-5-T10	●	○	40	51	300	55	10	37.5	30			

Compatible con el Inserto ZCC. / Compatible avec ZCC Plaquettes. / Compatible with ZCC Insert.

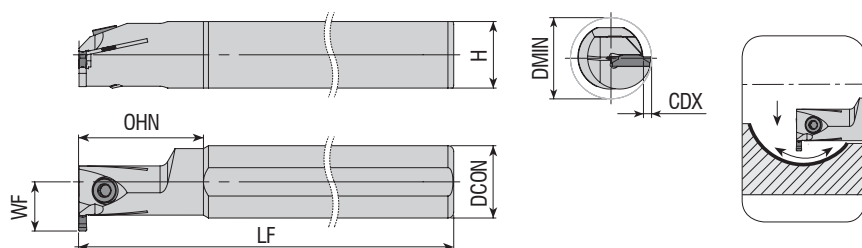

Código del Inserto Le Code de Commande Ordering Code	Stock		Dimension (mm) Dimension (mm) Dimension (mm)							Inserto Plaquette Insert	Recambios / Pièces de Rechange / Spare Parts	
	R	L	DCON	DMIN	LF	OHN	CDX	H	WF		Tornillo Vis Screw	Llaves Allen Clés Allen Allen Wrench
AIKT-SGC-R/L-25-3-T6	●	○	25	32	200	40	6	23	18.5	GCM N30	2504-M5x16 2004-M8x1x20	AAL-05-4
AIKT-SGC-R/L-32-3-T6	●	○	32	39	250	50	6	30	22			
AIKT-SGC-R/L-40-3-T6	●	○	40	47	300	55	6	37.5	26			

R: Derecha / Droite / Right L: Izquierda / Gauche / Left



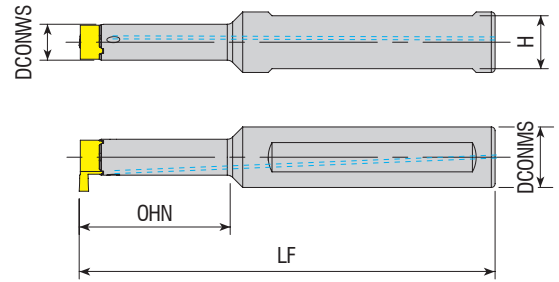

● En Existencia / En stock / In Stock ○ Artículo sin Existencia / Indisponible en Stock / Non Stock Item
 Compatible con el Inserto SMTM. / Compatible avec SMTM Plaquettes. / Compatible with SMTM Insert.

Ejemplo de Pedido / Exemple de Commande / Ordering Example

1 Piezas / pcs. / pcs. AIKT-ZCC2-R-16-2-T4



Código del Inserto
Le Code de Commande
Ordering Code

Stock Stock Stock	Dimension (mm) Dimension (mm) Dimension (mm)						Inserto Plaquette Insert	Recambios / Pièces de Rechange / Spare Parts	
	DCONMS	DCONWS	LF	OHN	H	Tornillo Vis Screw		Llave Torx Clé Torx Torx Wrench	
●	16	7.4	90	15	14				
●	16	7.4	90	22	14				
●	16	9.5	90	19	14		4015-M4x11	80-T15	
●	16	9.5	95	28	14				
●	16	9.5	110	40	14				

R: Derecha / Droite / Right L: Izquierda / Gauche / Left

● En Existencia / En stock / In Stock ○ Artículo sin Existencia / Indisponible en Stock / Non Stock Item

Compatible con el Inserto SNDVK. / Compatible avec SNDVK Plaquettes. / Compatible with SNDVK Insert.

Ejemplo de Pedido / Exemple de Commande / Ordering Example

1 Piezas / pcs. / pcs. AIKT-MB07-A16-090-15



konusulan
the spoken kalite...
quality...





HERRAMIENTAS DE PERFORACIÓN
OUTILS DE PERCAGE
DRILLING and HOLEMAKING TOOLS





*konusulan
the spoken kalite...
quality...*

U-DRILL

SISTEMA U DRILL
FORÊT SYSTÈME-U
U-DRILL SYSTEM

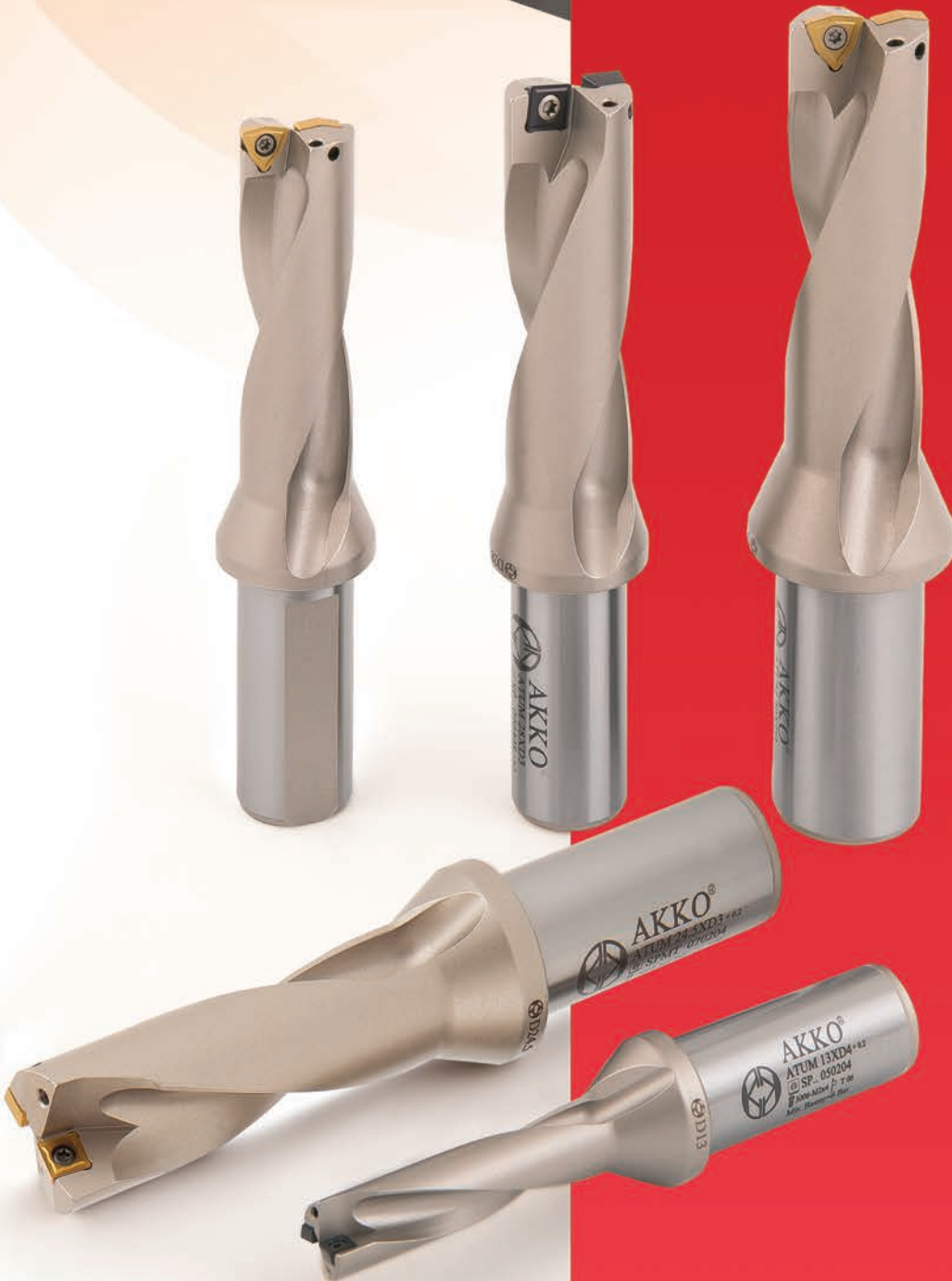



AKKO **A** **TUM** **16** x **D3**

S **P** **G** **T** **06** **02** **04**

2 Estilo de Corte / Type D'outil
Cutter Style

TUM: Taladro en U
U-Drill
U Drill

3 Diámetro de Herramienta / Diamètre de l'outil
Tool Diameter

4 Profundidad de Perforación / Profondeur du Perçage
Drilling Depth

5 Forma de Inserto / Forme de la Plaquette
Insert Shape

6 Inserto de ángulo libre Frietwinkel / Plaquettes Clearance Ange Freiwinkel
Insert Clearance Ange Freiwinkel

8 Tipo de Inserto / Type de Plaquette
Insert Type

X Especial
Spécial
Special

10 Grosor / Épaisseur
Thickness

01 s = 1.59
 T1 s = 1.98
 02 s = 2.38
 T2 s = 2.78
 03 s = 3.18
 T3 s = 3.97
 04 s = 4.76
 05 s = 5.56
 06 s = 6.35
 07 s = 7.94
 09 s = 9.52

7 Tolerancia / Tolérance
Tolerance

	IC	M	S
A	± 0.025	± 0.005	± 0.025
C	± 0.025	± 0.013	± 0.025
E	± 0.025	± 0.025	± 0.025
F	± 0.013	± 0.005	± 0.025
G	± 0.025	± 0.025	± 0.130
H	± 0.013	± 0.013	± 0.025
J	± 0.05-0.15	± 0.005	± 0.025
K	± 0.05-0.15	± 0.013	± 0.025
L	± 0.05-0.15	± 0.025	± 0.025
M	± 0.05-0.15	± 0.08-0.20	± 0.130
N	± 0.05-0.15	± 0.08-0.20	± 0.025
U	± 0.08-0.25	± 0.13-0.38	± 0.130

IC : Círculo Inscrito / Cercle Inscribed / Incribed Circle
 M : Remítase a la Figura / Reportez-vous à la Figure / Refer to Figure
 S : Grosor / Épaisseur / Thickness

9 Longitud del Filo / Longueur de Coupe
Cutting Edge Length

11 Radio de Esquina / Rayon de l'angle
Corner Radius

01 r = 0.1
 02 r = 0.2
 04 r = 0.4
 08 r = 0.8
 12 r = 1.2
 16 r = 1.6
 24 r = 2.4



Profundidad de Perforación = 2xDiámetro
Profondeur Perçage = 2xDiamètre
Drilling Depth = 2xDiameter

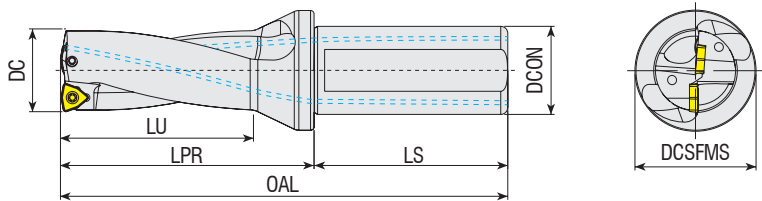

Código del Inserto Le Code de Commande Ordering Code	Stock Stock Stock	Dimension (mm) Dimension (mm) Dimension (mm)							Max. Desplazamiento (radial) Max. Offset (radial) Max. Offset (radial)		Inserto Plaquette Insert	Recambios / Pièces de Rechange / Spare Parts				
		DC	DCON	DCSFMS	OAL	LU	LPR	LS	X _{max}	DC _{max}		Tornillo Vis Screw	Llave Torx Cle Torx Torx Wrench			
ATUM 16XD2 WCM. 030208	●	16	25	34	110	32	54	56	1.5	19	WCM. 030208	3008-M2.5x6	80-T08			
ATUM 16.5XD2 WCM. 030208	●	16.5	25	34	110	32	54	56	1.5	19.5						
ATUM 17XD2 WCM. 030208	●	17	25	34	112	34	56	56	1.5	20						
ATUM 17.5XD2 WCM. 030208	●	17.5	25	34	112	34	56	56	1.5	20.5						
ATUM 18XD2 WCM. 030208	●	18	25	34	114	36	58	56	1.4	20.8						
ATUM 18.5XD2 WCM. 030208	●	18.5	25	34	114	36	58	56	1.3	21.1						
ATUM 19XD2 WCM. 030208	●	19	25	34	116	38	60	56	1.2	21.4						
ATUM 19.5XD2 WCM. 030208	●	19.5	25	34	116	38	60	56	1.2	21.9						
ATUM 20XD2 WCM. 040208	●	20	25	34	118	40	62	56	1.4	22.8				WCM. 040208	3008-M2.5x6	80-T08
ATUM 20.5XD2 WCM. 040208	●	20.5	25	34	118	40	62	56	1.4	23.3						
ATUM 21XD2 WCM. 040208	●	21	25	34	120	42	64	56	1	23						
ATUM 21.5XD2 WCM. 040208	●	21.5	25	34	120	42	64	56	1	23.5						
ATUM 22XD2 WCM. 040208	●	22	25	34	122	44	66	56	0.9	23.8						
ATUM 22.5XD2 WCM. 040208	●	22.5	25	34	122	44	66	56	0.9	24.3						
ATUM 23XD2 WCM. 040208	●	23	25	34	124	46	68	56	0.8	24.6						
ATUM 23.5XD2 WCM. 040208	●	23.5	25	34	124	46	68	56	0.8	25.1	WCM. 050308	3008-M3x8	80-T08			
ATUM 24XD2 WCM. 050308	●	24	25	34	126	48	70	56	1.4	26.8						
ATUM 24.5XD2 WCM. 050308	●	24.5	25	34	126	48	70	56	1.4	27.3						
ATUM 25XD2 WCM. 050308	●	25	25	34	128	50	72	56	1.4	27.8						
ATUM 25.5XD2 WCM. 050308	●	25.5	25	34	128	50	72	56	1.4	28.3						
ATUM 26XD2 WCM. 050308	●	26	25	34	130	52	74	56	1.4	28.8						
ATUM 26.5XD2 WCM. 050308	●	26.5	25	34	130	52	74	56	1.4	29.3						
ATUM 27XD2 WCM. 050308	●	27	25	34	132	54	76	56	1.4	29.8						
ATUM 27.5XD2 WCM. 050308	●	27.5	25	34	132	54	76	56	1.4	30.3						
ATUM 28XD2 WCM. 050308	●	28	25	34	134	56	78	56	1.4	30.8						
ATUM 28.5XD2 WCM. 050308	●	28.5	25	34	134	56	78	56	1.4	31.3						
ATUM 29XD2 WCM. 050308	●	29	25	34	136	58	80	56	1.4	31.8						
ATUM 29.5XD2 WCM. 050308	●	29.5	25	34	136	58	80	56	1.4	32.3						

R: Derecha / Droite / Right L: Izquierda / Gauche / Left

● En Existencia / En stock / In Stock ○ Artículo sin Existencia / Indisponible en Stock / Non Stock Item
Compatible con el Inserto ISO. / Compatible avec ISO Plaquettes. / Compatible with ISO Insert.

Ejemplo de Pedido / Exemple de Commande / Ordering Example

1 Piezas / pcs. / pcs. ATUM 16XD2 WCM. 030208

Guía del Usuario Para Taladros en U P: 367 / Guide de l'utilisateur Pour U-Drill P: P 367
User's Guide For U-Drills : P 368



Profundidad de Perforación = 2xDiámetro
Profondeur Perçage = 2xDiamètre
Drilling Depth = 2xDiameter

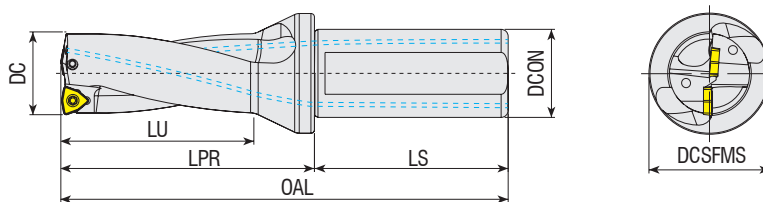

Código del Inserto Le Code de Commande Ordering Code	Stock Stock Stock	Dimension (mm) Dimension (mm) Dimension (mm)							Max. Desplazamiento (radial) Max. Offset (radial) Max. Offset (radial)		Inserto Plaquette Insert	Recambios / Pièces de Rechange / Spare Parts	
		DC	DCON	DCSFMS	OAL	LU	LPR	LS	X _{max}	DC _{max}		Tornillo Vis Screw	Llave Torx Clé Torx Torx Wrench
ATUM 30XD2 WCM. 06T308	●	30	32	44	147	60	87	60	2.4	34.8	WCM. 06T308	3010-M3.5x9	80-T10
ATUM 31XD2 WCM. 06T308	●	31	32	44	149	62	89	60	2.3	35.6			
ATUM 32XD2 WCM. 06T308	●	32	32	44	151	64	91	60	2.1	36.2			
ATUM 33XD2 WCM. 06T308	●	33	32	44	153	66	93	60	1.9	36.8			
ATUM 34XD2 WCM. 06T308	●	34	32	44	155	68	95	60	1.9	37.8			
ATUM 35XD2 WCM. 06T308	●	35	32	44	157	70	97	60	1.8	38.6			
ATUM 36XD2 WCM. 06T308	●	36	32	44	159	72	99	60	1.7	39.4			
ATUM 37XD2 WCM. 06T308	●	37	32	44	161	74	101	60	1.6	40.2			
ATUM 38XD2 WCM. 06T308	●	38	32	44	163	76	103	60	1.5	41			
ATUM 39XD2 WCM. 06T308	●	39	32	44	165	78	105	60	1.3	41.6			
ATUM 40XD2 WCM. 06T308	●	40	32	44	167	80	107	60	1	42			
ATUM 41XD2 WCM. 06T308	●	41	32	44	169	82	109	60	0.8	42.6			
ATUM 42XD2 WCM. 06T308	●	42	32	44	171	84	111	60	0.5	43			
ATUM 43XD2 WCM. 06T308	●	43	32	44	173	86	113	60	0.3	43.6			
ATUM 44XD2 WCM. 06T308	●	44	32	44	175	88	115	60	0	44			
ATUM 45XD2 WCM. 080412	●	45	40	54	192	90	122	70	3.3	51.6	WCM. 080412	4015-M4x11	80-T15
ATUM 46XD2 WCM. 080412	●	46	40	54	194	92	124	70	3	52			
ATUM 47XD2 WCM. 080412	●	47	40	54	196	94	126	70	2.8	52.6			
ATUM 48XD2 WCM. 080412	●	48	40	54	198	96	128	70	2.5	53			
ATUM 49XD2 WCM. 080412	●	49	40	54	200	98	130	70	2.2	53.4			
ATUM 50XD2 WCM. 080412	●	50	40	54	202	100	132	70	2	54			
ATUM 51XD2 WCM. 080412	●	51	40	54	204	102	134	70	1.8	54.6			
ATUM 52XD2 WCM. 080412	●	52	40	54	206	104	136	70	1.5	55			
ATUM 53XD2 WCM. 080412	●	53	40	54	208	106	138	70	1.3	55.6			
ATUM 54XD2 WCM. 080412	●	54	40	54	210	108	140	70	1	56			
ATUM 55XD2 WCM. 080412	●	55	40	54	212	110	142	70	0.8	56.6			
ATUM 56XD2 WCM. 080412	●	56	40	64	214	112	144	70	0.5	57			
ATUM 57XD2 WCM. 080412	●	57	40	64	216	114	146	70	0.3	57.6			
ATUM 58XD2 WCM. 080412	●	58	40	64	218	116	148	70	0	58			
ATUM 59XD2 WCM. 080412	●	59	40	64	220	118	150	70	0	59			
ATUM 60XD2 WCM. 080412	●	60	40	64	222	120	152	70	0	60			

R: Derecha / Droite / Right L: Izquierda / Gauche / Left

● En Existencia / En stock / In Stock ○ Artículo sin Existencia / Indisponible en Stock / Non Stock Item
Compatible con el Inserto ISO. / Compatible avec ISO Plaquettes. / Compatible with ISO Insert.

Ejemplo de Pedido / Exemple de Commande / Ordering Example

1 Piezas / pcs. / pcs. ATUM 30XD2 WCM. 06T308

Guía del Usuario Para Taladros en U P: 367 / Guide de l'utilisateur Pour U-Drill P: P 367 / User's Guide For U-Drills : P 368



Profundidad de Perforación = 3xDiámetro
Profondeur Perçage = 3xDiamètre
Drilling Depth = 3xDiameter

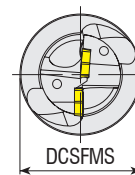
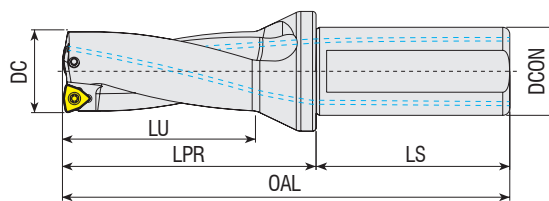

Código del Inserto Le Code de Commande Ordering Code	Stock Stock Stock	Dimension (mm) Dimension (mm) Dimension (mm)							Max. Desplazamiento (radial) Max. Offset (radial) Max. Offset (radial)		Inserto Plaquette Insert	Recambios / Pièces de Rechange / Spare Parts	
		DC	DCON	DCSFMS	OAL	LU	LPR	LS	X _{max}	DC _{max}		Tornillo Vis Screw	Llave Torx Cle Torx Torx Wrench
ATUM 16XD3 WCM. 030208	●	16	25	34	126	48	70	56	1.5	19	WCM. 030208	3008-M2.5x6	80-T08
ATUM 16.5XD3 WCM. 030208	●	16.5	25	34	126	48	70	56	1.5	19.5			
ATUM 17XD3 WCM. 030208	●	17	25	34	129	51	73	56	1.5	20			
ATUM 17.5XD3 WCM. 030208	●	17.5	25	34	129	51	73	56	1.5	20.5			
ATUM 18XD3 WCM. 030208	●	18	25	34	132	54	76	56	1.4	20.8			
ATUM 18.5XD3 WCM. 030208	●	18.5	25	34	132	54	76	56	1.3	21.1			
ATUM 19XD3 WCM. 030208	●	19	25	34	135	57	79	56	1.2	21.4			
ATUM 19.5XD3 WCM. 030208	●	19.5	25	34	135	57	79	56	1.2	21.9			
ATUM 20XD3 WCM. 040208	●	20	25	34	138	60	82	56	1.4	22.8	WCM. 040208	3008-M2.5x6	80-T08
ATUM 20.5XD3 WCM. 040208	●	20.5	25	34	138	60	82	56	1.4	23.3			
ATUM 21XD3 WCM. 040208	●	21	25	34	141	63	85	56	1	23			
ATUM 21.5XD3 WCM. 040208	●	21.5	25	34	141	63	85	56	1	23.5			
ATUM 22XD3 WCM. 040208	●	22	25	34	144	66	88	56	0.9	23.8			
ATUM 22.5XD3 WCM. 040208	●	22.5	25	34	144	66	88	56	0.9	24.3			
ATUM 23XD3 WCM. 040208	●	23	25	34	147	69	91	56	0.8	24.6			
ATUM 23.5XD3 WCM. 040208	●	23.5	25	34	147	69	91	56	0.8	25.1			
ATUM 24XD3 WCM. 050308	●	24	25	34	150	72	94	56	1.4	26.8	WCM. 050308	3008-M3x8	80-T08
ATUM 24.5XD3 WCM. 050308	●	24.5	25	34	150	72	94	56	1.4	27.3			
ATUM 25XD3 WCM. 050308	●	25	25	34	153	75	97	56	1.4	27.8			
ATUM 25.5XD3 WCM. 050308	●	25.5	25	34	153	75	97	56	1.4	28.3			
ATUM 26XD3 WCM. 050308	●	26	25	34	156	78	100	56	1.4	28.8			
ATUM 26.5XD3 WCM. 050308	●	26.5	25	34	156	78	100	56	1.4	29.3			
ATUM 27XD3 WCM. 050308	●	27	25	34	159	81	103	56	1.4	29.8			
ATUM 27.5XD3 WCM. 050308	●	27.5	25	34	159	81	103	56	1.4	30.3			
ATUM 28XD3 WCM. 050308	●	28	25	34	162	84	106	56	1.4	30.8			
ATUM 28.5XD3 WCM. 050308	●	28.5	25	34	162	84	106	56	1.4	31.3			
ATUM 29XD3 WCM. 050308	●	29	25	34	165	87	109	56	1.4	31.8			
ATUM 29.5XD3 WCM. 050308	●	29.5	25	34	165	87	109	56	1.4	32.3			
ATUM 30XD3 WCM. 06T308	●	30	32	44	177	90	117	60	2.4	34.8	WCM. 06T308	3010-M3.5x9	80-T10
ATUM 30.5XD3 WCM. 06T308	●	30.5	32	44	177	90	117	60	2.4	35.3			
ATUM 31XD3 WCM. 06T308	●	31	32	44	180	93	120	60	2.3	35.6			
ATUM 31.5XD3 WCM. 06T308	●	31.5	32	44	180	93	120	60	2.3	36.1			
ATUM 32XD3 WCM. 06T308	●	32	32	44	183	96	123	60	2.1	36.2			
ATUM 32.5XD3 WCM. 06T308	●	32.5	32	44	183	96	123	60	2.1	36.7			
ATUM 33XD3 WCM. 06T308	●	33	32	44	186	99	126	60	1.9	36.8			
ATUM 33.5XD3 WCM. 06T308	●	33.5	32	44	186	99	126	60	1.9	37.3			
ATUM 34XD3 WCM. 06T308	●	34	32	44	189	102	129	60	1.9	37.8			
ATUM 34.5XD3 WCM. 06T308	●	34.5	32	44	189	102	129	60	1.9	38.3			

R: Derecha / Droite / Right L: Izquierda / Gauche / Left

● En Existencia / En stock / In Stock ○ Artículo sin Existencia / Indisponible en Stock / Non Stock Item
Compatible con el Inserto ISO. / Compatible avec ISO Plaquettes. / Compatible with ISO Insert.

Ejemplo de Pedido / Exemple de Commande / Ordering Example

1 Piezas / pcs. / pcs. ATUM 16XD3 WCM. 030208

Guía del Usuario Para Taladros en U P: 367 / Guide de l'utilisateur Pour U-Drill P: P 367

User's Guide For U-Drills : P 368



Profundidad de Perforación = 3xDiámetro
 Profondeur Perçage = 3xDiamètre
 Drilling Depth = 3xDiameter

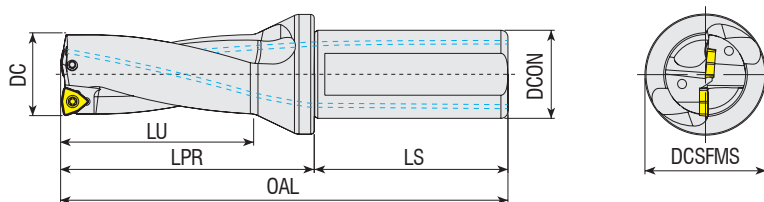

Código del Inserto
 Le Code de Commande
 Ordering Code

Stock Stock Stock	Dimension (mm) Dimension (mm) Dimension (mm)								Max. Desplazamiento (radial) Max. Offset (radial) Max. Offset (radial)		Inserto Plaquette Insert	Recambios / Pièces de Rechange / Spare Parts	
	DC	DCON	DCSFMS	OAL	LU	LPR	LS	X _{max}	DC _{max}	Tornillo Vis Screw		Llave Torx Clé Torx Torx Wrench	
●	35	32	44	192	105	132	60	1.8	38.6	WCM. 06T308	3010-M3.5x9	80-T10	
●	35.5	32	44	192	105	132	60	1.8	39.1				
●	36	32	44	195	108	135	60	1.7	39.4				
●	36.5	32	44	195	108	135	60	2	40.5				
●	37	32	44	198	111	138	60	1.6	40.2				
●	37.5	32	44	198	111	138	60	1.8	41.1				
●	38	32	44	201	114	141	60	1.5	41				
●	38.5	32	44	201	114	141	60	1.5	41.5				
●	39	32	44	204	117	144	60	1.3	41.6				
●	39.5	32	44	204	117	144	60	1.3	42.1				
●	40	32	44	207	120	147	60	1	42				
●	40.5	32	44	207	120	147	60	1	42.5				
●	41	32	44	210	123	150	60	0.8	42.6				
●	41.5	32	44	210	123	150	60	0.8	43.1				
●	42	32	44	213	126	153	60	0.5	43				
●	42.5	32	44	213	126	153	60	0.5	43.5				
●	43	32	44	216	129	156	60	0.3	43.6				
●	43.5	32	44	216	129	156	60	0.3	44.1				
●	44	32	44	219	132	159	60	0	44				
●	44.5	32	44	219	132	159	60	0	44.5				
●	45	40	54	237	135	167	70	3.3	51.6	WCM. 080412	4015-M4x11	80-T15	
●	45.5	40	54	237	135	167	70	3.3	52.1				
●	46	40	54	240	138	170	70	3	52				
●	47	40	54	243	141	173	70	2.8	52.6				
●	48	40	54	246	144	176	70	2.5	53				
●	49	40	54	249	147	179	70	2.2	53.4				
●	50	40	54	252	150	182	70	2	54				
●	51	40	54	255	153	185	70	1.8	54.6				
●	52	40	54	258	156	188	70	1.5	55				
●	53	40	54	261	159	191	70	1.3	55.6				
●	54	40	54	264	162	194	70	1	56				
●	55	40	54	267	165	197	70	0.8	56.6				
●	56	40	64	270	168	200	70	0.5	57				
●	57	40	64	273	171	203	70	0.3	57.6				
●	58	40	64	276	174	206	70	0	58				
●	59	40	64	279	177	209	70	0	59				
●	60	40	64	282	180	212	70	0	60				

R: Derecha / Droite / Right L: Izquierda / Gauche / Left
 ● En Existencia / En stock / In Stock ○ Artículo sin Existencia / Indisponible en Stock / Non Stock Item
 Compatible con el Inserto ISO. / Compatible avec ISO Plaquettes. / Compatible with ISO Insert.

Ejemplo de Pedido / Exemple de Commande / Ordering Example
 1 Piezas / pcs. / pcs. ATUM 35XD3 WCM. 06T308
 Guía del Usuario Para Taladros en U P: 367 / Guide de l'utilisateur Pour U-Drill P: P 367
 User's Guide For U-Drills : P 368



Profundidad de Perforación = 4xDiámetro
Profondeur Perçage = 4xDiamètre
Drilling Depth = 4xDiameter

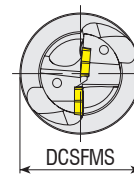
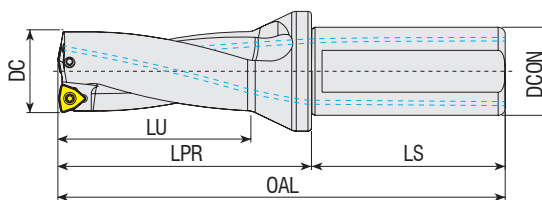

Código del Inserto Le Code de Commande Ordering Code	Stock Stock Stock	Dimension (mm) Dimension (mm) Dimension (mm)							Max. Desplazamiento (radial) Max. Offset (radial) Max. Offset (radial)		Inserto Plaquette Insert	Recambios / Pièces de Rechange / Spare Parts	
		DC	DCON	DCSFMS	OAL	LU	LPR	LS	X _{max}	DC _{max} [mm]		Tornillo Vis Screw	Llave Torx Clé Torx Torx Wrench
ATUM 16XD4 WCM. 030208	●	16	25	34	142	64	86	56	1.5	19	WCM. 030208		
ATUM 16.5XD4 WCM. 030208	○	16.5	25	34	142	64	86	56	1.5	19.5			
ATUM 17XD4 WCM. 030208	●	17	25	34	146	68	90	56	1.5	20			
ATUM 17.5XD4 WCM. 030208	●	17.5	25	34	146	68	90	56	1.5	20.5			
ATUM 18XD4 WCM. 030208	●	18	25	34	150	72	94	56	1.4	20.8			
ATUM 18.5XD4 WCM. 030208	○	18.5	25	34	150	72	94	56	1.3	21.1			
ATUM 19XD4 WCM. 030208	●	19	25	34	154	76	98	56	1.2	21.4			
ATUM 19.5XD4 WCM. 030208	○	19.5	25	34	154	76	98	56	1.2	21.9			
ATUM 20XD4 WCM. 040208	●	20	25	34	158	80	102	56	1.4	22.8			
ATUM 20.5XD4 WCM. 040208	○	20.5	25	34	158	80	102	56	1.4	23.3			
ATUM 21XD4 WCM. 040208	●	21	25	34	162	84	106	56	1	23			
ATUM 21.5XD4 WCM. 040208	○	21.5	25	34	162	84	106	56	1	23.5			
ATUM 22XD4 WCM. 040208	●	22	25	34	166	88	110	56	0.9	23.8			
ATUM 22.5XD4 WCM. 040208	●	22.5	25	34	166	88	110	56	0.9	24.3			
ATUM 23XD4 WCM. 040208	●	23	25	34	170	92	114	56	0.8	24.6			
ATUM 23.5XD4 WCM. 040208	○	23.5	25	34	170	92	114	56	0.8	25.1	WCM. 050308	3008-M3x8	
ATUM 24XD4 WCM. 050308	●	24	25	34	174	96	118	56	1.4	26.8			
ATUM 24.5XD4 WCM. 050308	○	24.5	25	34	174	96	118	56	1.4	27.3			
ATUM 25XD4 WCM. 050308	●	25	25	34	178	100	122	56	1.4	27.8			
ATUM 25.5XD4 WCM. 050308	○	25.5	25	34	178	100	122	56	1.4	28.3			
ATUM 26XD4 WCM. 050308	●	26	25	34	182	104	126	56	1.4	28.8			
ATUM 26.5XD4 WCM. 050308	●	26.5	25	34	182	104	126	56	1.4	29.3			
ATUM 27XD4 WCM. 050308	●	27	25	34	186	108	130	56	1.4	29.8			
ATUM 27.5XD4 WCM. 050308	○	27.5	25	34	186	108	130	56	1.4	30.3			
ATUM 28XD4 WCM. 050308	●	28	25	34	190	112	134	56	1.4	30.8			
ATUM 28.5XD4 WCM. 050308	●	28.5	25	34	190	112	134	56	1.4	31.3			
ATUM 29XD4 WCM. 050308	●	29	25	34	194	116	138	56	1.4	31.8			
ATUM 29.5XD4 WCM. 050308	○	29.5	25	34	194	116	138	56	1.4	32.3			

R: Derecha / Droite / Right L: Izquierda / Gauche / Left
● En Existencia / En stock / In Stock ○ Artículo sin Existencia / Indisponible en Stock / Non Stock Item
Compatible con el Inserto ISO. / Compatible avec ISO Plaquettes. / Compatible with ISO Insert.

Ejemplo de Pedido / Exemple de Commande / Ordering Example
1 Piezas / pcs. / pcs. ATUM 16XD4 WCM. 030208
Guía del Usuario Para Taladros en U P: 367 / Guide de l'utilisateur Pour U-Drill P: P.367
User's Guide For U-Drills : P.368



Profundidad de Perforación = 4xDiámetro
 Profondeur Perçage = 4xDiètre
 Drilling Depth = 4xDiameter

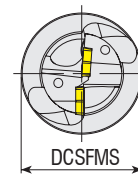
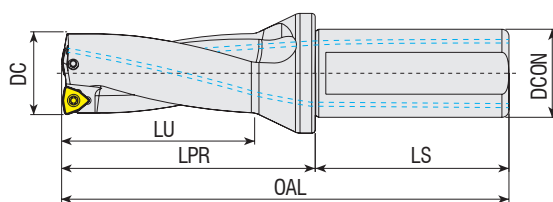

Código del Inserto Le Code de Commande Ordering Code	Stock Stock Stock	Dimension (mm) Dimension (mm) Dimension (mm)							Max. Desplazamiento (radial) Max. Offset (radial) Max. Offset (radial)		Inserto Plaquette Insert	Recambios / Pièces de Rechange / Spare Parts	
		DC	DCON	DCSFMS	OAL	LU	LPR	LS	X _{max} [mm] DC _{max} [mm]			Tornillo Vis Screw	Llave Torx Clé Torx Torx Wrench
									X _{max}	DC _{max}			
ATUM 30XD4 WCM. 06T308	●	30	32	44	207	120	147	60	2.4	34.8	WCM. 06T308	3010-M3.5x9	80-T10
ATUM 31XD4 WCM. 06T308	●	31	32	44	211	124	151	60	2.3	35.6			
ATUM 32XD4 WCM. 06T308	●	32	32	44	215	128	155	60	2.1	36.2			
ATUM 33XD4 WCM. 06T308	●	33	32	44	219	132	159	60	1.9	36.8			
ATUM 33.5XD4 WCM. 06T308	●	33.5	32	44	219	132	159	60	1.9	37.3			
ATUM 34XD4 WCM. 06T308	●	34	32	44	223	136	163	60	1.9	37.8			
ATUM 35XD4 WCM. 06T308	●	35	32	44	227	140	167	60	1.8	38.6			
ATUM 36XD4 WCM. 06T308	●	36	32	44	231	144	171	60	1.7	39.4			
ATUM 37XD4 WCM. 06T308	●	37	32	44	235	148	175	60	1.6	40.2			
ATUM 38XD4 WCM. 06T308	●	38	32	44	239	152	179	60	1.5	41			
ATUM 38.5XD4 WCM. 06T308	●	38.5	32	44	239	152	179	60	1.5	41.5			
ATUM 39XD4 WCM. 06T308	●	39	32	44	243	156	183	60	1.3	41.6			
ATUM 40XD4 WCM. 06T308	●	40	32	44	247	160	187	60	1	42			
ATUM 41XD4 WCM. 06T308	●	41	32	44	251	164	191	60	0.8	42.6			
ATUM 42XD4 WCM. 06T308	●	42	32	44	255	168	195	60	0.5	43			
ATUM 43XD4 WCM. 06T308	●	43	32	44	259	172	199	60	0.3	43.6			
ATUM 44XD4 WCM. 06T308	●	44	32	44	263	176	203	60	0	44			
ATUM 45XD4 WCM. 080412	●	45	40	54	282	180	212	70	3.3	51.6	WCM. 080412	4015-M4x11	80-T15
ATUM 46XD4 WCM. 080412	●	46	40	54	286	184	216	70	3	52			
ATUM 47XD4 WCM. 080412	●	47	40	54	290	188	220	70	2.8	52.6			
ATUM 48XD4 WCM. 080412	●	48	40	54	294	192	224	70	2.5	53			
ATUM 49XD4 WCM. 080412	●	49	40	54	298	196	228	70	2.2	53.4			
ATUM 50XD4 WCM. 080412	●	50	40	54	302	200	232	70	2	54			

R: Derecha / Droite / Right L: Izquierda / Gauche / Left
 ● En Existencia / En stock / In Stock ○ Artículo sin Existencia / Indisponible en Stock / Non Stock Item
 Compatible con el Inserto ISO. / Compatible avec ISO Plaquettes. / Compatible with ISO Insert.

Ejemplo de Pedido / Exemple de Commande / Ordering Example
 1 Piezas / pcs. / pcs. ATUM 30XD4 WCM. 06T308
 Guía del Usuario Para Taladros en U P: 367 / Guide de l'utilisateur Pour U-Drill P: P 367
 User's Guide For U-Drills : P 368



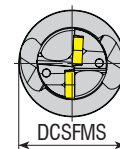
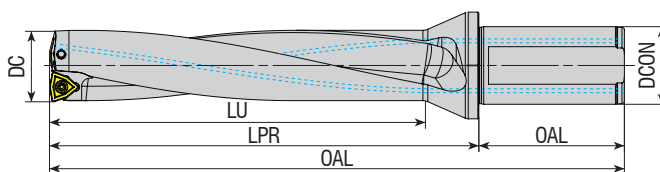

Profundidad de Perforación = 5xDiámetro
Profondeur Perçage = 5xDiamètre
Drilling Depth = 5xDiameter

Código del Inserto Le Code de Commande Ordering Code	Stock Stock Stock	Dimension (mm) Dimension (mm) Dimension (mm)							Max. Desplazamiento (radial) Max. Offset (radial) Max. Offset (radial)	Inserto Plaquette Insert	Recambios / Pièces de Rechange / Spare Parts		
		DC	DCON	DCSFMS	OAL	LU	LPR	LS			Tornillo Vis Screw	Llave Torx Clé Torx Torx Wrench	
ATUM 20XD5 WCM. 040208	●	20	25	34	178	100	122	56	1.4	22.8	WCM. 040208	3008-M2.5x6	80-T08
ATUM 21XD5 WCM. 040208	●	21	25	34	183	105	127	56	1	23			
ATUM 22XD5 WCM. 040208	●	22	25	34	188	110	132	56	0.9	23.8			
ATUM 23XD5 WCM. 040208	●	23	25	34	193	115	137	56	0.8	24.6			
ATUM 24XD5 WCM. 050308	●	24	25	34	198	120	142	56	1.4	26.8	WCM. 050308	3008-M3x8	80-T08
ATUM 25XD5 WCM. 050308	●	25	25	34	203	125	147	56	1.4	27.8			
ATUM 26XD5 WCM. 050308	●	26	25	34	208	130	152	56	1.4	28.8			
ATUM 27XD5 WCM. 050308	●	27	25	34	213	135	157	56	1.4	29.8			
ATUM 28XD5 WCM. 050308	●	28	25	34	218	140	162	56	1.4	30.8			
ATUM 29XD5 WCM. 050308	●	29	25	34	223	145	167	56	1.4	31.8			
ATUM 30XD5 WCM. 06T308	●	30	32	44	237	150	177	60	2.4	34.8	WCM. 06T308	3010-M3.5x9	80-T10
ATUM 31XD5 WCM. 06T308	●	31	32	44	242	155	182	60	2.3	35.6			
ATUM 32XD5 WCM. 06T308	●	32	32	44	247	160	187	60	2.1	36.2			
ATUM 33XD5 WCM. 06T308	●	33	32	44	252	165	192	60	1.9	36.8			
ATUM 34XD5 WCM. 06T308	●	34	32	44	257	170	197	60	1.9	37.8			
ATUM 35XD5 WCM. 06T308	●	35	32	44	262	175	202	60	1.8	38.6			
ATUM 37XD5 WCM. 06T308	●	37	32	44	272	185	212	60	1.6	40.2			
ATUM 38XD5 WCM. 06T308	●	38	32	44	277	190	217	60	1.5	41			
ATUM 46XD5 WCM. 080412	●	46	40	54	332	230	262	70	3	52	WCM. 080412	4015-M4x11	80-T15

R: Derecha / Droite / Right L: Izquierda / Gauche / Left

● En Existencia / En stock / In Stock ○ Artículo sin Existencia / Indisponible en Stock / Non Stock Item
Compatible con el Inserto ISO. / Compatible avec ISO Plaquettes. / Compatible with ISO Insert.

Ejemplo de Pedido / Exemple de Commande / Ordering Example

1 Piezas / pcs. / pcs. ATUM 20XD5 WCM. 040208

Guía del Usuario Para Taladros en U.P. 367 / Guide de l'utilisateur Pour U-Drill P: P 367
User's Guide For U-Drills : P 368



Profundidad de Perforación = 2xDiámetro
 Profondeur Perçage = 2xDiamètre
 Drilling Depth = 2xDiameter

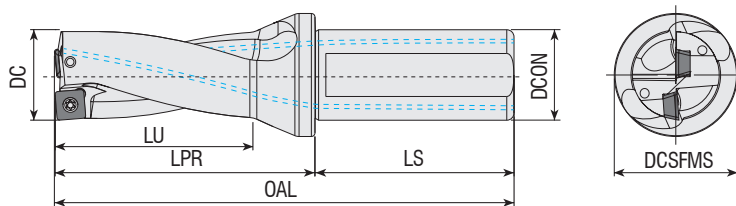

Código del Inserto Le Code de Commande Ordering Code	Stock Stock Stock	Dimension (mm) Dimension (mm) Dimension (mm)								Max. Desplazamiento (radial) Max. Offset (radial) Max. Offset (radial)		Inserto Plaquette Insert	Recambios / Pièces de Rechange / Spare Parts	
		DC	DCON	DCSFMS	OAL	LU	LPR	LS	X _{max}	DC _{max}	Tornillo Vis Screw		Llave Torx Clé Torx Torx Wrench	
ATUM 12.5XD2 SP. 050204	●	12.5	20	25	96	24	46	50	0.5	13.5	SP. 050204	3006-M2x4	80-T06	
ATUM 13XD2 SP. 050204	●	13	20	25	98	26	48	50	0.5	14				
ATUM 13.5XD2 SP. 050204	●	13.5	20	25	98	26	48	50	0.5	14.5				
ATUM 14XD2 SP. 050204	●	14	20	25	100	28	50	50	0.5	15				
ATUM 14.5XD2 SP. 050204	●	14.5	20	25	100	28	50	50	0.5	15.5				
ATUM 15XD2 SP. 050204	●	15	20	25	102	30	52	50	0.5	16				
ATUM 15.5XD2 SP. 060204	●	15.5	20	25	102	30	52	50	0.5	16.5	SP. 060204	3007-M2.2x5	80-T07	
ATUM 16XD2 SP. 060204	●	16	25	34	110	32	54	56	0.5	17				
ATUM 16.5XD2 SP. 060204	●	16.5	25	34	110	32	54	56	0.5	17.5				
ATUM 17XD2 SP. 060204	●	17	25	34	112	34	56	56	0.5	18				
ATUM 17.5XD2 SP. 060204	●	17.5	25	34	112	34	56	56	0.5	18.5				
ATUM 18XD2 SP. 060204	●	18	25	34	114	36	58	56	0.5	19				
ATUM 18.5XD2 SP. 060204	●	18.5	25	34	114	36	58	56	0.5	19.5				
ATUM 19XD2 SP. 060204	●	19	25	34	116	38	60	56	0.25	19.5				
ATUM 19.5XD2 SP. 060204	●	19.5	25	34	116	38	60	56	0.25	20				
ATUM 20XD2 SP. 060204	●	20	25	34	118	40	62	56	0	20				
ATUM 20.5XD2 SP. 060204	●	20.5	25	34	118	40	62	56	0	20.5				
ATUM 21XD2 SP. 060204	●	21	25	34	120	42	64	56	0	21				
ATUM 21.5XD2 SP. 060204	●	21.5	25	34	120	42	64	56	0	21.5				
ATUM 22XD2 SP. 07T308	●	22	25	34	122	44	66	56	0.5	23	SP. 07T308	3008-M2.5x6	80-T08	
ATUM 22.5XD2 SP. 07T308	●	22.5	25	34	122	44	66	56	0.5	23.5				
ATUM 23XD2 SP. 07T308	●	23	25	34	124	46	68	56	0.5	24				
ATUM 23.5XD2 SP. 07T308	●	23.5	25	34	124	46	68	56	0.5	24.5				
ATUM 24XD2 SP. 07T308	●	24	25	34	126	48	70	56	0.5	25				
ATUM 24.5XD2 SP. 07T308	●	24.5	25	34	126	48	70	56	0.5	25.5				
ATUM 25XD2 SP. 07T308	●	25	25	34	128	50	72	56	0.25	25.5				
ATUM 25.5XD2 SP. 07T308	●	25.5	25	34	128	50	72	56	0.25	26				
ATUM 26XD2 SP. 07T308	●	26	25	34	130	52	74	56	0	26				
ATUM 26.5XD2 SP. 07T308	●	26.5	25	34	130	52	74	56	0	26.5				
ATUM 27XD2 SP. 07T308	●	27	25	34	132	54	76	56	0	27				
ATUM 27.5XD2 SP. 07T308	●	27.5	25	34	132	54	76	56	0	27.5				

R: Derecha / Droite / Right L: Izquierda / Gauche / Left

● En Existencia / En stock / In Stock ○ Artículo sin Existencia / Indisponible en Stock / Non Stock Item
 Compatible con el Inserto TGTC. / Compatible avec TGTC Plaquettes. / Compatible with TGTC Insert.

Ejemplo de Pedido / Exemple de Commande / Ordering Example

1 Piezas / pcs. / pcs. ATUM 12.5XD2 SP. 050204

Guía del Usuario Para Taladros en U P: 367 / Guide de l'utilisateur Pour U-Drill P: P 367

User's Guide For U-Drills : P 368



Profundidad de Perforación = 2xDiámetro
 Profondeur Perçage = 2xDiamètre
 Drilling Depth = 2xDiameter

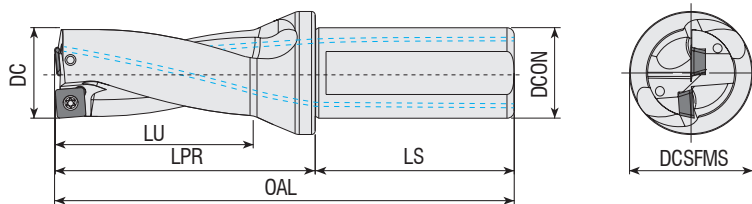

Código del Inserto Le Code de Commande Ordering Code	Stock Stock Stock	Dimension (mm) Dimension (mm) Dimension (mm)								Max. Desplazamiento (radial) Max. Offset (radial) Max. Offset (radial)		Inserto Plaquette Insert	Recambios / Pièces de Rechange / Spare Parts	
		DC	DCON	DCSFMS	OAL	LU	LPR	LS	X _{max}	DC _{max} [mm]	Tornillo Vis Screw		Llave Torx Clé Torx Torx Wrench	
ATUM 28XD2 SP. 090408	●	28	25	34	134	56	78	56	0.5	29	SP. 090408	4015-M3.5x9	80-T15	
ATUM 28.5XD2 SP. 090408	●	28.5	25	34	134	56	78	56	0.5	29.5				
ATUM 29XD2 SP. 090408	●	29	25	34	136	58	80	56	0.5	30				
ATUM 29.5XD2 SP. 090408	●	29.5	25	34	136	58	80	56	0.5	30.5				
ATUM 30XD2 SP. 090408	●	30	32	44	147	60	87	60	0.5	31				
ATUM 31XD2 SP. 090408	●	31	32	44	149	62	89	60	0.25	31.5				
ATUM 32XD2 SP. 090408	●	32	32	44	151	64	91	60	0	32				
ATUM 33XD2 SP. 090408	●	33	32	44	153	66	93	60	0	33				
ATUM 34XD2 SP. 110408	●	34	32	44	155	68	95	60	0.5	35	SP. 110408	4015-M4x11	80-T15	
ATUM 35XD2 SP. 110408	●	35	32	44	157	70	97	60	0.5	36				
ATUM 36XD2 SP. 110408	●	36	32	44	159	72	99	60	0.5	37				
ATUM 37XD2 SP. 110408	●	37	32	44	161	74	101	60	0.5	38				
ATUM 38XD2 SP. 110408	●	38	32	44	163	76	103	60	0.5	39				
ATUM 39XD2 SP. 110408	●	39	32	44	165	78	105	60	0.5	40				
ATUM 40XD2 SP. 110408	●	40	32	44	167	80	107	60	0.25	40.5				
ATUM 41XD2 SP. 110408	●	41	32	44	169	82	109	60	0	41				
ATUM 42XD2 SP. 140512	●	42	32	44	171	84	111	60	0.5	43	SP. 140512	1020-M5x11	80-T20	
ATUM 43XD2 SP. 140512	●	43	32	44	173	86	113	60	0.5	44				
ATUM 44XD2 SP. 140512	●	44	32	44	175	88	115	60	0.5	45				
ATUM 45XD2 SP. 140512	●	45	40	54	192	90	122	70	0.5	46				
ATUM 46XD2 SP. 140512	●	46	40	54	194	92	124	70	0.5	47				
ATUM 47XD2 SP. 140512	●	47	40	54	196	94	126	70	0.5	48				
ATUM 48XD2 SP. 140512	●	48	40	54	198	96	128	70	0.25	48.5				
ATUM 49XD2 SP. 140512	●	49	40	54	200	98	130	70	0	49				
ATUM 50XD2 SP. 140512	●	50	40	54	202	100	132	70	0	50				

R: Derecha / Droite / Right L: Izquierda / Gauche / Left

● En Existencia / En stock / In Stock ○ Artículo sin Existencia / Indisponible en Stock / Non Stock Item
 Compatible con el Inserto TGTC. / Compatible avec TGTC Plaquettes. / Compatible with TGTC Insert.

Ejemplo de Pedido / Exemple de Commande / Ordering Example
 1 Piezas / pcs. / pcs. ATUM 28XD2 SP. 090408
 Guía del Usuario Para Taladros en U P: 367 / Guide de l'utilisateur Pour U-Drill P: P 367
 User's Guide For U-Drills : P 368



Profundidad de Perforación = 3xDiámetro
Profondeur Perçage = 3xDiamètre
Drilling Depth = 3xDiameter

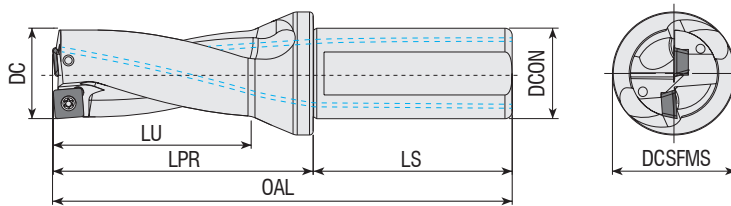

Código del Inserto Le Code de Commande Ordering Code	Stock Stock Stock	Dimension (mm) Dimension (mm) Dimension (mm)								Max. Desplazamiento (radial) Max. Offset (radial) Max. Offset (radial)	Inserto Plaque Insert	Recambios / Pièces de Rechange / Spare Parts		
		DC	DCON	DCSFMS	OAL	LU	LPR	LS	X _{max} X _{max} [mm]			DC _{max} DC _{max} [mm]	Tornillo Vis Screw	Llave Torx Clé Torx Torx Wrench
ATUM 12.5XD3 SP. 050204	●	12.5	20	25	108	36	58	50	0.5	13.5	SP. 050204	3006-M2x4	80-T06	
ATUM 13XD3 SP. 050204	●	13	20	25	111	39	61	50	0.5	14				
ATUM 13.5XD3 SP. 050204	●	13.5	20	25	111	39	61	50	0.5	14.5				
ATUM 14XD3 SP. 050204	●	14	20	25	114	42	64	50	0.5	15				
ATUM 14.5XD3 SP. 050204	●	14.5	20	25	114	42	64	50	0.5	15.5				
ATUM 15XD3 SP. 050204	●	15	20	25	117	45	67	50	0.5	16				
ATUM 15.5XD3 SP. 060204	●	15.5	20	25	117	45	67	50	0.5	16.5	SP. 060204	3007-M2.2x5	80-T07	
ATUM 16XD3 SP. 060204	●	16	25	34	126	48	70	56	0.5	17				
ATUM 16.5XD3 SP. 060204	●	16.5	25	34	126	48	70	56	0.5	17.5				
ATUM 17XD3 SP. 060204	●	17	25	34	129	51	73	56	0.5	18				
ATUM 17.5XD3 SP. 060204	●	17.5	25	34	129	51	73	56	0.5	18.5				
ATUM 18XD3 SP. 060204	●	18	25	34	132	54	76	56	0.5	19				
ATUM 18.5XD3 SP. 060204	●	18.5	25	34	132	54	76	56	0.5	19.5				
ATUM 19XD3 SP. 060204	●	19	25	34	135	57	79	56	0.25	19.5				
ATUM 19.5XD3 SP. 060204	●	19.5	25	34	135	57	79	56	0.25	20				
ATUM 20XD3 SP. 060204	●	20	25	34	138	60	82	56	0	20				
ATUM 20.5XD3 SP. 060204	●	20.5	25	34	138	60	82	56	0	20.5				
ATUM 21XD3 SP. 060204	●	21	25	34	141	63	85	56	0	21				
ATUM 21.5XD3 SP. 060204	●	21.5	25	34	141	63	85	56	0	21.5				
ATUM 22XD3 SP. 07T308	●	22	25	34	144	66	88	56	0.5	23	SP. 07T308	3008-M2.5x6	80-T08	
ATUM 22.5XD3 SP. 07T308	●	22.5	25	34	144	66	88	56	0.5	23.5				
ATUM 23XD3 SP. 07T308	●	23	25	34	147	69	91	56	0.5	24				
ATUM 23.5XD3 SP. 07T308	●	23.5	25	34	147	69	91	56	0.5	24.5				
ATUM 24XD3 SP. 07T308	●	24	25	34	150	72	94	56	0.5	25				
ATUM 24.5XD3 SP. 07T308	●	24.5	25	34	150	72	94	56	0.5	25.5				
ATUM 25XD3 SP. 07T308	●	25	25	34	153	75	97	56	0.25	25.5				
ATUM 25.5XD3 SP. 07T308	●	25.5	25	34	153	75	97	56	0.25	26				
ATUM 26XD3 SP. 07T308	●	26	25	34	156	78	100	56	0	26				
ATUM 26.5XD3 SP. 07T308	●	26.5	25	34	156	78	100	56	0	26.5				
ATUM 27XD3 SP. 07T308	●	27	25	34	159	81	103	56	0	27				
ATUM 27.5XD3 SP. 07T308	●	27.5	25	34	159	81	103	56	0	27.5				
ATUM 28XD3 SP. 090408	●	28	25	34	162	84	106	56	0.5	29	SP. 090408	4015-M3.5x9	80-T15	
ATUM 28.5XD3 SP. 090408	●	28.5	25	34	162	84	106	56	0.5	29.5				
ATUM 29XD3 SP. 090408	●	29	25	34	165	87	109	56	0.5	30				
ATUM 29.5XD3 SP. 090408	●	29.5	25	34	165	87	109	56	0.5	30.5				
ATUM 30XD3 SP. 090408	●	30	32	44	177	90	117	60	0.5	31				
ATUM 30.5XD3 SP. 090408	●	30.5	32	44	177	90	117	60	0.5	31.5				
ATUM 31XD3 SP. 090408	●	31	32	44	180	93	120	60	0.25	31.5				
ATUM 31.5XD3 SP. 090408	●	31.5	32	44	180	93	120	60	0.25	32				
ATUM 32XD3 SP. 090408	●	32	32	44	183	96	123	60	0	32				
ATUM 32.5XD3 SP. 090408	●	32.5	32	44	183	96	123	60	0	32.5				
ATUM 33XD3 SP. 090408	●	33	32	44	186	99	126	60	0	33				
ATUM 33.5XD3 SP. 090408	●	33.5	32	44	186	99	126	60	0	33.5				

R: Derecha / Droite / Right L: Izquierda / Gauche / Left

● En Existencia / En stock / In Stock ○ Artículo sin Existencia / Indisponible en Stock / Non Stock Item

Compatible con el Inserto TGTC. / Compatible avec TGTC Plaquettes. / Compatible with TGTC Insert.

Ejemplo de Pedido / Exemple de Commande / Ordering Example

1 Piezas / pcs. / pcs. ATUM 12.5XD3 SP. 050204

Guía del Usuario Para Taladros en U P: 367 / Guide de l'utilisateur Pour U-Drill P: 367 / User's Guide For U-Drills : P 368



Profundidad de Perforación = 3xDiámetro
 Profondeur Perçage = 3xDiamètre
 Drilling Depth = 3xDiameter

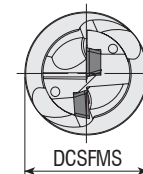
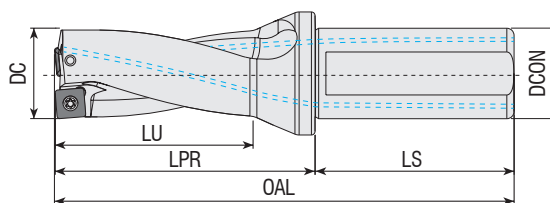

Código del Inserto
Le Code de Commande
Ordering Code

Stock Stock Stock	Dimension (mm) Dimension (mm) Dimension (mm)								Max. Desplazamiento (radial) Max. Offset (radial) Max. Offset (radial)		Inserto Plaquette Insert	Recambios / Pièces de Rechange / Spare Parts	
	DC	DCON	DCSFMS	OAL	LU	LPR	LS	X _{max}	DC _{max}	Tornillo Vis Screw		Llave Torx Clé Torx Torx Wrench	
●	34	32	44	189	102	129	60	1.4	30.8	SP. 110408	4015-M4x11	80-T15	
●	34.5	32	44	189	102	129	60	1.4	31.3				
●	35	32	44	192	105	132	60	1.4	31.8				
●	35.5	32	44	192	105	132	60	1.4	32.3				
●	36	32	44	195	108	135	60	2.4	34.8				
●	36.5	32	44	195	108	135	60	2.3	35.6				
●	37	32	44	198	111	138	60	2.1	36.2				
●	37.5	32	44	198	111	138	60	1.9	36.8				
●	38	32	44	201	114	141	60	1.9	37.8				
●	38.5	32	44	201	114	141	60	1.8	38.6				
●	39	32	44	204	117	144	60	1.7	39.4				
●	39.5	32	44	204	117	144	60	1.6	40.2				
●	40	32	44	207	120	147	60	1.5	41				
●	40.5	32	44	207	120	147	60	1.3	41.6				
●	41	32	44	210	123	150	60	1	42				
●	41.5	32	44	210	123	150	60	0.8	42.6				
●	42	32	44	213	126	153	60	0.5	43				SP. 140512
●	42.5	32	44	213	126	153	60	0.3	43.6				
●	43	32	44	216	129	156	60	0	44				
●	43.5	32	44	216	129	156	60	3.3	51.6				
●	44	32	44	219	132	159	60	3	52				
●	44.5	32	44	219	132	159	60	2.8	52.6				
●	45	40	54	237	135	167	70	2.5	53				
●	45.5	40	54	237	135	167	70	2.2	53.4				
●	46	40	54	240	138	170	70	2	54				
●	47	40	54	243	141	173	70	0.2	47.4				
●	48	40	54	246	144	176	70	0	48				
●	49	40	54	249	147	179	70	0	49				
●	50	40	54	252	150	182	70	0	50				
●	51	40	54	255	153	185	70	0	51				
●	52	40	54	258	156	188	70	0	52				

R: Derecha / Droite / Right L: Izquierda / Gauche / Left

● En Existencia / En stock / In Stock ○ Artículo sin Existencia / Indisponible en Stock / Non Stock Item
 Compatible con el Inserto TGTC. / Compatible avec TGTC Plaquettes. / Compatible with TGTC Insert.

Ejemplo de Pedido / Exemple de Commande / Ordering Example

1 Piezas / pcs. / pcs. ATUM 34XD3 SP. 110408

Guía del Usuario Para Taladros en U P: 367 / Guide de l'utilisateur Pour U-Drill P: P.367

User's Guide For U-Drills : P.368



Profundidad de Perforación = 4xDiámetro
Profondeur Perçage = 4xDiamètre
Drilling Depth = 4xDiameter

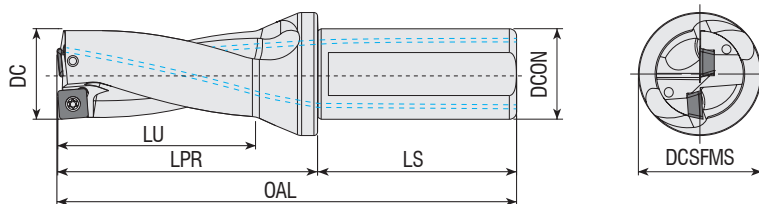

Código del Inserto Le Code de Commande Ordering Code				Stock Stock Stock	Dimension (mm) Dimension (mm) Dimension (mm)								Max. Desplazamiento (radial) Max. Offset (radial) Max. Offset (radial)	Inserto Plaquette Insert	Recambios / Pièces de Rechange / Spare Parts	
					DC	DCON	DCSFMS	OAL	LU	LPR	LS	Tornillo Vis Screw			Llave Torx Clé Torx Torx Wrench	
ATUM 13XD4 SP. 050204	●	13	20	25	124	52	74	50	0.5	14	SP. 050204	3006-M2x4	80-T06			
ATUM 14XD4 SP. 050204	●	14	20	25	128	56	78	50	0.5	15						
ATUM 15XD4 SP. 050204	●	15	20	25	132	60	82	50	0.5	16						
ATUM 16XD4 SP. 060204	●	16	25	34	142	64	86	56	0.5	17						
ATUM 17XD4 SP. 060204	●	17	25	34	146	68	90	56	0.5	18						
ATUM 17.5XD4 SP. 060204	●	17	25	34	146	68	90	56	0.5	18.5						
ATUM 18XD4 SP. 060204	●	18	25	34	150	72	94	56	0.5	19	SP. 060204	3007-M2.2x5	80-T07			
ATUM 19XD4 SP. 060204	●	19	25	34	154	76	98	56	0.25	19.5						
ATUM 19.5XD4 SP. 060204	●	19.5	25	34	154	76	98	56	0.25	20						
ATUM 20XD4 SP. 060204	●	20	25	34	158	80	102	56	0	20						
ATUM 21XD4 SP. 060204	●	21	25	34	162	84	106	56	0	21						
ATUM 22XD4 SP. 07T308	●	22	25	34	166	88	110	56	0.5	23				SP. 07T308	3008-M2.5x6	80-T08
ATUM 23XD4 SP. 07T308	●	23	25	34	170	92	114	56	0.5	24						
ATUM 23.5XD4 SP. 07T308	●	23.5	25	34	170	92	114	56	0.5	24.5						
ATUM 24XD4 SP. 07T308	●	24	25	34	174	96	118	56	0.5	25						
ATUM 25XD4 SP. 07T308	●	25	25	34	178	100	122	56	0.25	25.5						
ATUM 26XD4 SP. 07T308	●	26	25	34	182	104	126	56	0	26						
ATUM 27XD4 SP. 07T308	●	27	25	34	186	108	130	56	0	27	SP. 090408	4015-M3.5x9	80-T15			
ATUM 27.5XD4 SP. 07T308	●	27.5	25	34	186	108	130	56	0	27.5						
ATUM 28XD4 SP. 090408	●	28	25	34	190	112	134	56	0.5	29						
ATUM 29XD4 SP. 090408	●	29	25	34	194	116	138	56	0.5	30						
ATUM 30XD4 SP. 090408	●	30	32	44	207	120	147	60	0.5	31						
ATUM 31XD4 SP. 090408	●	31	32	44	211	124	151	60	0.25	31.5						
ATUM 32XD4 SP. 090408	●	32	32	44	215	128	155	60	0	32	SP. 110408	4015-M4x11	80-T15			
ATUM 33XD4 SP. 090408	●	33	32	44	219	132	159	60	0	33						
ATUM 33.5XD4 SP. 090408	●	33.5	32	44	219	132	159	60	0	33.5						
ATUM 34XD4 SP. 110408	●	34	32	44	223	136	163	60	0.5	35						
ATUM 35XD4 SP. 110408	●	35	32	44	227	140	167	60	0.5	36						
ATUM 36XD4 SP. 110408	●	36	32	44	231	144	171	60	0.5	37						
ATUM 37XD4 SP. 110408	●	37	32	44	235	148	175	60	0.5	38	SP. 140512	1020-M5x11	80-T20			
ATUM 38XD4 SP. 110408	●	38	32	44	239	152	179	60	0.5	39						
ATUM 39XD4 SP. 110408	●	39	32	44	243	156	183	60	0.5	40						
ATUM 40XD4 SP. 110408	●	40	32	44	247	160	187	60	0.25	40.5						
ATUM 41XD4 SP. 110408	●	41	32	44	251	164	191	60	0	41						
ATUM 42XD4 SP. 140512	●	42	32	44	255	168	195	60	0.5	43						
ATUM 43XD4 SP. 140512	●	43	32	44	259	172	199	60	0.5	44						
ATUM 44XD4 SP. 140512	●	44	32	44	263	176	203	60	0.5	45						

R: Derecha / Droite / Right L: Izquierda / Gauche / Left

● En Existencia / En stock / In Stock ○ Artículo sin Existencia / Indisponible en Stock / Non Stock Item
Compatible con el Inserto TGTC. / Compatible avec TGTC Plaquettes. / Compatible with TGTC Insert.

Ejemplo de Pedido / Exemple de Commande / Ordering Example

1 Piezas / pcs. / pcs. ATUM 13XD4 SP. 050204

Guía del Usuario Para Taladros en U P: 367 / Guide de l'utilisateur Pour U-Drill P: P 367

User's Guide For U-Drills : P 368

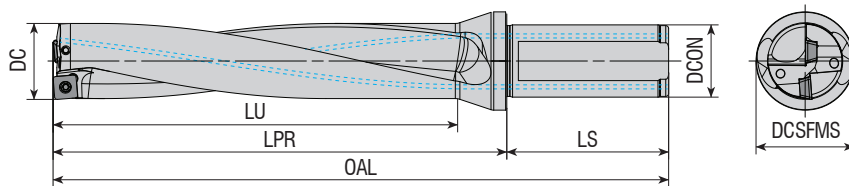

Profundidad de Perforación = 5xDiámetro
Profondeur Perçage = 5xDiamètre
Drilling Depth = 5xDiameter

Código del Inserto
Le Code de Commande
Ordering Code

Stock
Stock
Stock

Dimension (mm)
Dimension (mm)
Dimension (mm)

Max. Desplazamiento (radial)
Max. Offset (radial)
Max. Offset (radial)

Inserto
Plaquette
Insert

Recambios / Pièces de Rechange / Spare Parts

Tornillo
Vis
Screw

Llave Torx
Clé Torx
Torx Wrench

Código del Inserto Le Code de Commande Ordering Code	Stock Stock Stock	Dimension (mm) Dimension (mm) Dimension (mm)							Max. Desplazamiento (radial) Max. Offset (radial) Max. Offset (radial)		Inserto Plaquette Insert	Tornillo Vis Screw	Llave Torx Clé Torx Torx Wrench
		DC	DCON	DCSFMS	OAL	LU	LPR	LS	X _{max} X _{max} [mm]	DC _{max} [mm]			
ATUM 14XD5 SP. 050204	●	14	20	25	142	70	92	50	0.5	15.00	SP. 050204	3006-M2x4	80-T06
ATUM 16XD5 SP. 060204	●	16	25	34	158	80	102	56	0.5	17.00			
ATUM 17XD5 SP. 060204	●	17	25	34	163	85	107	56	0.5	18.00			
ATUM 18XD5 SP. 060204	●	18	25	34	168	90	112	56	0.5	19.00			
ATUM 19XD5 SP. 060204	●	19	25	34	173	95	117	56	0.25	19.50			
ATUM 20XD5 SP. 060204	●	20	25	34	178	100	122	56	0	20.00			
ATUM 21XD5 SP. 060204	●	21	25	34	183	105	127	56	0	21.00	SP. 060204	3007-M2.2x5	80-T07
ATUM 22XD5 SP. 07T308	●	22	25	34	188	110	132	56	0.5	23.00			
ATUM 22XD5 SP. 07T308-32	●	22	32	44	197	110	137	60	0.5	23.00			
ATUM 23XD5 SP. 07T308	●	23	25	34	193	115	137	56	0.5	24.00			
ATUM 23XD5 SP. 07T308-32	●	23	32	44	202	115	142	60	0.5	24.00			
ATUM 24XD5 SP. 07T308-32	●	24	32	44	207	120	147	60	0.5	25.00			
ATUM 25XD5 SP. 07T308	●	25	25	34	203	125	147	56	0.25	25.50	SP. 07T308	3008-M2.5x6	80-T08
ATUM 25XD5 SP. 07T308-32	●	25	32	44	212	125	152	60	0.25	25.50			
ATUM 26XD5 SP. 07T308	●	26	25	34	208	130	152	56	0	26.00			
ATUM 26XD5 SP. 07T308-32	●	26	32	44	217	130	157	60	0	26.00			
ATUM 27XD5 SP. 07T308	●	27	25	34	213	135	157	56	0	27.00			
ATUM 27XD5 SP. 07T308-32	●	27	32	44	222	135	162	60	0	27.00			
ATUM 28XD5 SP. 090408-32	●	28	32	44	227	140	167	60	0.5	29.00	SP. 090408	4015-M3.5x9	80-T15
ATUM 29XD5 SP. 090408-32	●	29	32	44	232	145	172	60	0.5	30.00			
ATUM 30XD5 SP. 090408	●	30	32	44	237	150	177	60	0.5	31.00			
ATUM 31XD5 SP. 090408	●	31	32	44	242	155	182	60	0.25	31.50			
ATUM 32XD5 SP. 090408	●	32	32	44	247	160	187	60	0	32.00			
ATUM 33XD5 SP. 090408	●	33	32	44	252	165	192	60	0	33.00			

R: Derecha / Droite / Right L: Izquierda / Gauche / Left

● En Existencia / En stock / In Stock ○ Artículo sin Existencia / Indisponible en Stock / Non Stock Item
Compatible con el Inserto TGTC. / Compatible avec TGTC Plaquettes. / Compatible with TGTC Insert.

Ejemplo de Pedido / Exemple de Commande / Ordering Example

1 Piezas / pcs. / pcs. ATUM 14XD5 SP. 050204

Guía del Usuario Para Taladros en U P: 367 / Guide de l'utilisateur Pour U-Drill P: P 367

User's Guide For U-Drills : P 368



Profundidad de Perforación = 2xDiámetro
 Profondeur Perçage = 2xDiamètre
 Drilling Depth = 2xDiameter

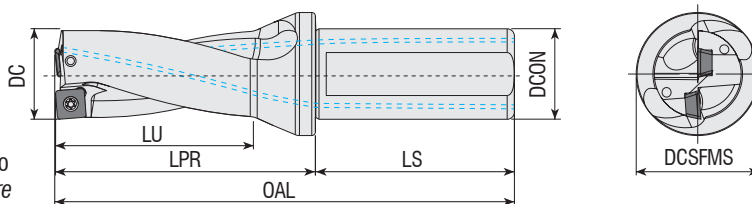

Código del Inserto
 Le Code de Commande
 Ordering Code

Stock Stock Stock	Dimension (mm) Dimension (mm) Dimension (mm)								Max. Desplazamiento (radial) Max. Offset (radial) Max. Offset (radial)	Inserto Plaque Insert	Recambios / Pièces de Rechange / Spare Parts		
	DC	DCON	DCSFMS	OAL	LU	LPR	LS	Tornillo Vis Screw			Llave Torx Clé Torx Torx Wrench		
ATUM 12.5XD2 SPGT 050204	●	12.5	20	25	96	24	46	50	0.5	13.5	SPGT 050204	3006-M2x4	80-T06
ATUM 13XD2 SPGT 050204	●	13	20	25	98	26	48	50	0.5	14			
ATUM 13.5XD2 SPGT 050204	●	13.5	20	25	98	26	48	50	0.5	14.5			
ATUM 14XD2 SPGT 050204	●	14	20	25	100	28	50	50	0.5	15			
ATUM 15XD2 SPGT 050204	●	15	20	25	102	30	52	50	0.5	16			
ATUM 16XD2 SPGT 060204	●	16	25	34	110	32	54	56	0.5	17	SPGT 060204	3007-M2.2x5	80-T07
ATUM 16.5XD2 SPGT 060204	●	16.5	25	34	110	32	54	56	0.5	17.5			
ATUM 17XD2 SPGT 060204	●	17	25	34	112	34	56	56	0.5	18			
ATUM 17.5XD2 SPGT 060204	●	17.5	25	34	112	34	56	56	0.5	18.5			
ATUM 18XD2 SPGT 060204	●	18	25	34	114	36	58	56	0.5	19			
ATUM 19XD2 SPGT 060204	●	19	25	34	116	38	60	56	0.25	19.5			
ATUM 20XD2 SPGT 060204	●	20	25	34	118	40	62	56	0	20			
ATUM 22XD2 SPGT 07T308	●	22	25	34	122	44	66	56	0.5	23	SPGT 07T308	3008-M2.5x6	80-T08
ATUM 22.5XD2 SPGT 07T308	●	22.5	25	34	122	44	66	56	0.5	23.5			
ATUM 23XD2 SPGT 07T308	●	23	25	34	124	46	68	56	0.5	24			
ATUM 24XD2 SPGT 07T308	●	24	25	34	126	48	70	56	0.5	25			
ATUM 25XD2 SPGT 07T308	●	25	25	34	128	50	72	56	0.25	25.5			
ATUM 26XD2 SPGT 07T308	●	26	25	34	130	52	74	56	0	26	SPGT 090408	4015-M3.5x9	80-T15
ATUM 28XD2 SPGT 090408	●	28	25	34	134	56	78	56	0.5	29			
ATUM 29XD2 SPGT 090408	●	29	25	34	136	58	80	56	0.5	30			
ATUM 30XD2 SPGT 090408	●	30	32	44	147	60	87	60	0.5	31	SPGT 110408	4015-M4x11	80-T15
ATUM 32XD2 SPGT 090408	●	32	32	44	151	64	91	60	0	32			
ATUM 35XD2 SPGT 110408	●	35	32	44	157	70	97	60	0.5	36	SPGT 110408	4015-M4x11	80-T15
ATUM 36XD2 SPGT 110408	●	36	32	44	159	72	99	60	0.5	37			
ATUM 40XD2 SPGT 110408	●	40	32	44	167	80	107	60	0.25	40.5			

R: Derecha / Droite / Right L: Izquierda / Gauche / Left
 ● En Existencia / En stock / In Stock ○ Artículo sin Existencia / Indisponible en Stock / Non Stock Item
 Compatible con el Inserto ZCC. / Compatible avec ZCC Plaquettes. / Compatible with ZCC Insert.

Ejemplo de Pedido / Exemple de Commande / Ordering Example
 1 Piezas / pcs. / pcs. ATUM 12.5XD2 SPGT 050204
 Guía del Usuario Para Taladros en U P: 367 / Guide de l'utilisateur Pour U-Drill P: P 367
 User's Guide For U-Drills : P 368





Profundidad de Perforación = 3xDiámetro
Profondeur Perçage = 3xDiamètre
Drilling Depth = 3xDiameter

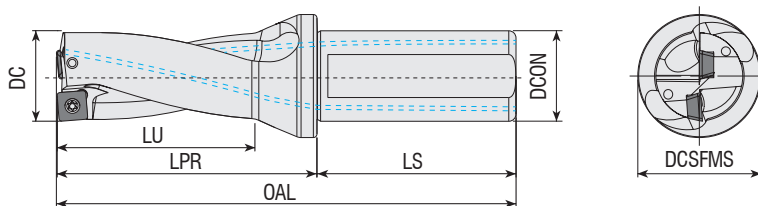

Código del Inserto
Le Code de Commande
Ordering Code

Stock
Stock
Stock

Dimension (mm)
Dimension (mm)
Dimension (mm)

Max. Desplazamiento (radial)
Max. Offset (radial)
Max. Offset (radial)

Inserto
Plaquette
Insert

Recambios / Pièces de Rechange / Spare Parts

Tornillo
Vis
Screw

Llave Torx
Cle Torx
Torx Wrench

DC

DCON

DCSFMS

OAL

LU

LPR

LS

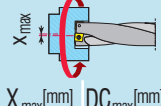

X_{max} [mm] DC_{max} [mm]

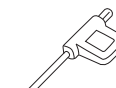

ATUM 12.5XD3 SPGT 050204	●	12.5	20	25	108	36	58	50	0.5	13.5	SPGT 050204	3006-M2x4	80-T06
ATUM 13XD3 SPGT 050204	●	13	20	25	111	39	61	50	0.5	14			
ATUM 13.5XD3 SPGT 050204	●	13.5	20	25	111	39	61	50	0.5	14.5			
ATUM 14XD3 SPGT 050204	●	14	20	25	114	42	64	50	0.5	15			
ATUM 14.5XD3 SPGT 050204	●	14.5	20	25	114	42	64	50	0.5	15.5			
ATUM 15XD3 SPGT 050204	●	15	20	25	117	45	67	50	0.5	16			
ATUM 15.5XD3 SPGT 060204	●	15.5	20	25	117	45	67	50	0.5	16.5	SPGT 060204	3007-M2.2x5	80-T07
ATUM 16XD3 SPGT 060204	●	16	25	34	126	48	70	56	0.5	17			
ATUM 16.5XD3 SPGT 060204	●	16.5	25	34	126	48	70	56	0.5	17.5			
ATUM 17XD3 SPGT 060204	●	17	25	34	129	51	73	56	0.5	18			
ATUM 17.5XD3 SPGT 060204	●	17.5	25	34	129	51	73	56	0.5	18.5			
ATUM 18XD3 SPGT 060204	●	18	25	34	132	54	76	56	0.5	19			
ATUM 18.5XD3 SPGT 060204	●	18.5	25	34	132	54	76	56	0.5	19.5			
ATUM 19XD3 SPGT 060204	●	19	25	34	135	57	79	56	0.25	19.5			
ATUM 19.5XD3 SPGT 060204	●	19.5	25	34	135	57	79	56	0.25	20			
ATUM 20XD3 SPGT 060204	●	20	25	34	138	60	82	56	0	20			
ATUM 20.5XD3 SPGT 060204	●	20.5	25	34	138	60	82	56	0	20.5			
ATUM 21XD3 SPGT 060204	●	21	25	34	141	63	85	56	0	21			
ATUM 21.5XD3 SPGT 060204	●	21.5	25	34	141	63	85	56	0	21.5			
ATUM 22XD3 SPGT 07T308	●	22	25	34	144	66	88	56	0.5	23	SPGT 07T308	3008-M2.5x6	80-T08
ATUM 22.5XD3 SPGT 07T308	●	22.5	25	34	144	66	88	56	0.5	23.5			
ATUM 23XD3 SPGT 07T308	●	23	25	34	147	69	91	56	0.5	24			
ATUM 23.5XD3 SPGT 07T308	●	23.5	25	34	147	69	91	56	0.5	24.5			
ATUM 24XD3 SPGT 07T308	●	24	25	34	150	72	94	56	0.5	25			
ATUM 24.5XD3 SPGT 07T308	●	24.5	25	34	150	72	94	56	0.5	25.5			
ATUM 25XD3 SPGT 07T308	●	25	25	34	153	75	97	56	0.25	25.5			
ATUM 25.5XD3 SPGT 07T308	●	25.5	25	34	153	75	97	56	0.25	26			
ATUM 26XD3 SPGT 07T308	●	26	25	34	156	78	100	56	0	26			
ATUM 26.5XD3 SPGT 07T308	●	26.5	25	34	156	78	100	56	0	26.5			
ATUM 27XD3 SPGT 07T308	●	27	25	34	159	81	103	56	0	27			
ATUM 27.5XD3 SPGT 07T308	●	27.5	25	34	159	81	103	56	0	27.5			
ATUM 28XD3 SPGT 090408	●	28	25	34	162	84	106	56	0.5	29	SPGT 090408	4015-M3.5x9	80-T15
ATUM 28.5XD3 SPGT 090408	●	28.5	25	34	162	84	106	56	0.5	29.5			
ATUM 29XD3 SPGT 090408	●	29	25	34	165	87	109	56	0.5	30			
ATUM 29.5XD3 SPGT 090408	●	29.5	25	34	165	87	109	56	0.5	30.5			
ATUM 30XD3 SPGT 090408	●	30	32	44	177	90	117	60	0.5	31			
ATUM 31XD3 SPGT 090408	●	31	32	44	180	93	120	60	0.25	31.5			
ATUM 32XD3 SPGT 090408	●	32	32	44	183	96	123	60	0	32			
ATUM 33XD3 SPGT 090408	●	33	32	44	186	99	126	60	0	33			

R: Derecha / Droite / Right L: Izquierda / Gauche / Left

● En Existencia / En stock / In Stock ○ Artículo sin Existencia / Indisponible en Stock / Non Stock Item
Compatible con el Inserto ZCC. / Compatible avec ZCC Plaquettes. / Compatible with ZCC Insert.

Ejemplo de Pedido / Exemple de Commande / Ordering Example

1 Piezas / pcs. / pcs. ATUM 12.5XD3 SPGT 050204

Guía del Usuario Para Taladros en U P: 367 / Guide de l'utilisateur Pour U-Drill P: P 367

User's Guide For U-Drills : P 367





Profundidad de Perforación = 3xDiámetro
 Profondeur Perçage = 3xDiamètre
 Drilling Depth = 3xDiameter

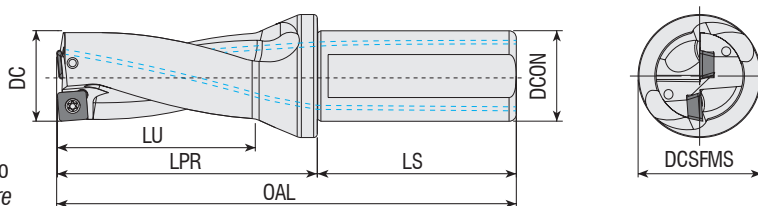

Código del Inserto
Le Code de Commande
Ordering Code

Stock Stock Stock	Dimension (mm) Dimension (mm) Dimension (mm)								Max. Desplazamiento (radial) Max. Offset (radial) Max. Offset (radial)		Inserto Plaquette Insert	Recambios / Pièces de Rechange / Spare Parts	
	DC	DCON	DCSFMS	OAL	LU	LPR	LS	X _{max}	DC _{max}	Tornillo Vis Screw		Llave Torx Clé Torx Torx Wrench	
●	34	32	44	189	102	129	60	0.5	35	SPGT 110408	4015-M4x11	80-T15	
●	35	32	44	192	105	132	60	0.5	36				
●	37	32	44	198	111	138	60	0.5	38				
●	38	32	44	201	114	141	60	0.5	39				
●	39	32	44	204	117	144	60	0.5	40				
●	40	32	44	207	120	147	60	0.25	40.5				
●	42	32	44	213	126	153	60	0.5	43	SPGT 140512	1020-M5x11	80-T20	
●	43	32	44	216	129	156	60	0.5	44				
●	44	32	44	219	132	159	60	0.5	45				
●	49	40	54	249	147	179	70	0	49				
●	49	40	54	249	147	179	70	0	49				
●	50	40	54	252	150	182	70	0	50				

R: Derecha / Droite / Right L: Izquierda / Gauche / Left
 ● En Existencia / En stock / In Stock ○ Artículo sin Existencia / Indisponible en Stock / Non Stock Item
 Compatible con el Inserto ZCC. / Compatible avec ZCC Plaquettes. / Compatible with ZCC Insert.

Ejemplo de Pedido / Exemple de Commande / Ordering Example
 1 Piezas / pcs. / pcs. ATUM 34XD3 SPGT 110408
 Guía del Usuario Para Taladros en U P: 367 / Guide de l'utilisateur Pour U-Drill P: P 367
 User's Guide For U-Drills : P 368





Profundidad de Perforación = 4xDiámetro
 Profondeur Perçage = 4xDiamètre
 Drilling Depth = 4xDiameter

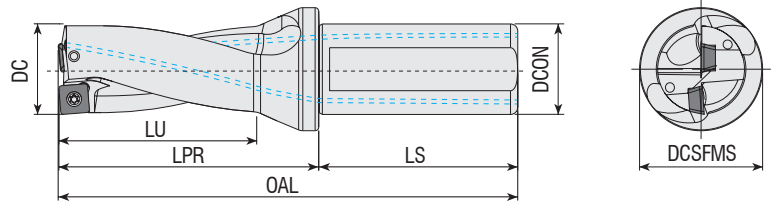

Código del Inserto
Le Code de Commande
Ordering Code

Stock Stock Stock	Dimension (mm) Dimension (mm) Dimension (mm)								Max. Desplazamiento (radial) Max. Offset (radial) Max. Offset (radial)		Inserto Plaquette Insert	Recambios / Pièces de Rechange / Spare Parts	
	DC	DCON	DCSFMS	OAL	LU	LPR	LS	X _{max}	DC _{max}	Tornillo Vis Screw		Llave Torx Clé Torx Torx Wrench	
●	13	20	25	124	52	74	50	0.5	14	SPGT 050204	3006-M2x4	80-T06	
●	14	20	25	128	56	78	50	0.5	15				
●	15	20	25	132	60	82	50	0.5	16				
●	16	25	34	142	64	86	56	0.5	17				
●	17	25	34	146	68	90	56	0.5	18	SPGT 060204	3007-M2.2x5	80-T07	
●	17.5	25	34	146	68	90	56	0.5	18.5				
●	18	25	34	150	72	94	56	0.5	19				
●	19	25	34	154	76	98	56	0.25	19.5				
●	19.5	25	34	154	76	98	56	0.25	20				
●	20	25	34	158	80	102	56	0	20				
●	21	25	34	162	84	106	56	0	21	SPGT 07T308	3008-M2.5x6	80-T08	
●	22	25	34	166	88	110	56	0.5	23				
●	23	25	34	170	92	114	56	0.5	24				
●	23.5	25	34	170	92	114	56	0.5	24.5				
●	24	25	34	174	96	118	56	0.5	25				
●	25	25	34	178	100	122	56	0.25	25.5				
●	26	25	34	182	104	126	56	0	26				
●	27.5	25	34	186	108	130	56	0	27.5				
●	28	25	34	190	112	134	56	0.5	29	SPGT 090408	4015-M3.5x9	80-T15	
●	29	25	34	194	116	138	56	0.5	30				
●	30	32	44	207	120	147	60	0.5	31				
●	33.5	32	44	219	132	159	60	0	33.5				
●	38	32	44	239	152	179	60	0.5	39	SPGT 110408	4015-M4x11	80-T15	

R: Derecha / Droite / Right L: Izquierda / Gauche / Left

● En Existencia / En stock / In Stock ○ Artículo sin Existencia / Indisponible en Stock / Non Stock Item
 Compatible con el Inserto ZCC. / Compatible avec ZCC Plaquettes. / Compatible with ZCC Insert.

Ejemplo de Pedido / Exemple de Commande / Ordering Example

1 Piezas / pcs. / pcs. ATUM 13XD4 SPGT 050204

Guía del Usuario Para Taladros en U P: 367 / Guide de l'utilisateur Pour U-Drill P: P 367

User's Guide For U-Drills : P 368





Profundidad de Perforación = 3xDiámetro
 Profondeur Perçage = 3xDiamètre
 Drilling Depth = 3xDiameter

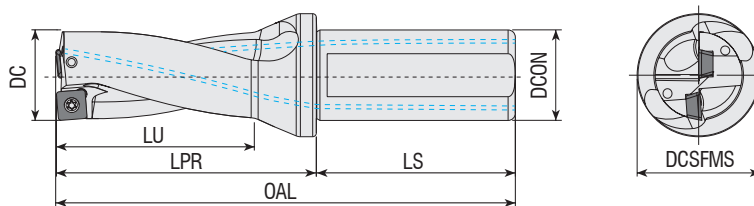

Código del Inserto Le Code de Commande Ordering Code	Stock Stock Stock	Dimension (mm) Dimension (mm) Dimension (mm)								Max. Desplazamiento (radial) Max. Offset (radial) Max. Offset (radial)	Inserto Plaquette Insert	Recambios / Pièces de Rechange / Spare Parts	
		DC	DCON	DCSFMS	OAL	LU	LPR	LS	Tornillo Vis Screw			Llave Torx Clé Torx Torx Wrench	
ATUM 14XD3 SO.. 050204	●	14	20	25	114	42	64	50	1.4	16.8	SO.. 050204	3006-M2x4	80-T06
ATUM 15XD3 SO.. 050204	●	15	20	25	117	45	67	50	1.2	17.4			
ATUM 16XD3 SO.. 050204	●	16	25	34	126	48	70	56	0.9	17.8			
ATUM 16.5XD3 SO.. 050204	●	16.5	25	34	126	48	70	56	0.8	18.1			
ATUM 17XD3 SO.. 050204	●	17	25	34	129	51	73	56	0.65	18.3			
ATUM 17.5XD3 SO.. 050204	●	17.5	25	34	129	51	73	56	0.5	18.5	SO.. 060304	3007-M2.2x5	80-T07
ATUM 18XD3 SO.. 060304	●	18	25	34	132	54	76	56	1.15	20.3			
ATUM 19XD3 SO.. 060304	●	19	25	34	135	57	79	56	0.9	20.8			
ATUM 20XD3 SO.. 060304	●	20	25	34	138	60	82	56	0.65	21.3			
ATUM 21XD3 SO.. 070305	●	21	25	34	141	63	85	56	1.75	24.5			
ATUM 22XD3 SO.. 070305	●	22	25	34	144	66	88	56	1.5	25			
ATUM 22.5XD3 SO.. 070305	●	22.5	25	34	144	66	88	56	1.35	25.2			
ATUM 23XD3 SO.. 070305	●	23	25	34	147	69	91	56	1.25	25.5			
ATUM 24XD3 SO.. 070305	●	24	25	34	150	72	94	56	1	26	SO.. 09T306	4010-M3x8	80-T10
ATUM 25XD3 SO.. 09T306	●	25	25	34	153	75	97	56	2.25	29.5			
ATUM 26XD3 SO.. 09T306	●	26	25	34	156	78	100	56	2	30			
ATUM 27XD3 SO.. 09T306	●	27	25	34	159	81	103	56	1.75	30.5			
ATUM 29XD3 SO.. 09T306	●	29	25	34	174	87	114	56	1.25	31.5			
ATUM 30XD3 SO.. 09T306	●	30	32	44	177	90	117	60	1	32			
ATUM 31XD3 SO.. 09T306	●	31	32	44	200	93	120	60	0.75	32.5			
ATUM 33XD3 SO.. 09T306	●	33	32	44	186	99	126	60	0.5	34			
ATUM 35XD3 SO.. 120408	●	35	32	44	192	105	132	60	2.75	40.5			
ATUM 36XD3 SO.. 120408	●	36	32	44	195	108	135	60	2.5	41	SO.. 120408	4015-M4X11	80-T15
ATUM 37XD3 SO.. 120408	●	37	32	44	198	111	138	60	2.25	41.5			
ATUM 38XD3 SO.. 120408	●	38	32	44	201	114	141	60	1.75	41.5			
ATUM 39XD3 SO.. 120408	●	39	32	44	204	117	144	60	1.75	42.5			
ATUM 40XD3 SO.. 120408	●	40	32	44	207	120	147	60	1.5	43			
ATUM 43XD3 SO.. 120408	●	43	32	44	216	129	156	60	0.75	44.5			

R: Derecha / Droite / Right L: Izquierda / Gauche / Left
 ● En Existencia / En stock / In Stock ○ Artículo sin Existencia / Indisponible en Stock / Non Stock Item
 Compatible con el Inserto ISCR. / Compatible avec ISCR Plaquettes. / Compatible with ISCR Insert.

Ejemplo de Pedido / Exemple de Commande / Ordering Example
 1 Piezas / pcs. / pcs. ATUM 14XD3 SO.. 050204
 Guía del Usuario Para Taladros en U P: 367 / Guide de l'utilisateur Pour U-Drill P: P 367
 User's Guide For U-Drills : P 368



Profundidad de Perforación = 4xDiámetro
 Profondeur Perçage = 4xDiamètre
 Drilling Depth = 4xDiameter

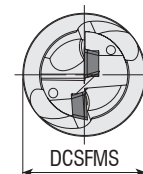
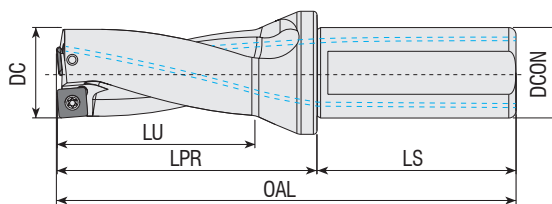

Código del Inserto Le Code de Commande Ordering Code	Stock Stock Stock	Dimension (mm) Dimension (mm) Dimension (mm)							Max. Desplazamiento (radial) Max. Offset (radial) Max. Offset (radial)		Inserto Plaquette Insert	Recambios / Pièces de Rechange / Spare Parts		
		DC	DCON	DCSFMS	OAL	LU	LPR	LS	X _{max}	DC _{max} [mm]		Tornillo Vis Screw	Llave Torx Clé Torx Torx Wrench	
ATUM 14XD4 SO.. 050204	●	14	20	25	128	56	78	50	1.4	16.8	SO.. 050204	3006-M2x4	80-T06	
ATUM 14.5XD4 SO.. 050204	●	14.5	20	25	128	56	78	50	1.3	17.1				
ATUM 15XD4 SO.. 050204	●	15	20	25	132	60	62	50	1.2	17.4				
ATUM 15.5XD4 SO.. 050204	●	15.5	20	25	132	60	82	50	1	17.5				
ATUM 17XD4 SO.. 050204	●	17	25	34	146	68	90	56	0.65	18.3	SO.. 060304	3007-M2.2x5	80-T07	
ATUM 19XD4 SO.. 060304	●	19	25	34	154	76	98	56	0.9	20.8				
ATUM 19.5XD4 SO.. 060304	●	19.5	25	34	154	76	98	56	0.75	21				
ATUM 20XD4 SO.. 060304	●	20	25	34	158	80	102	56	0.65	21.3				
ATUM 21XD4 SO.. 070305	●	21	25	34	162	84	106	56	1.75	24.5	SO.. 070305	3008-M2.5x6	80-T08	
ATUM 22XD4 SO.. 070305	●	22	25	34	166	88	110	56	1.5	25				
ATUM 22.5XD4 SO.. 070305	●	22.5	25	34	166	88	110	56	1.35	25.2				
ATUM 23XD4 SO.. 070305	●	23	25	34	170	92	114	56	1.25	25.5				
ATUM 24XD4 SO.. 070305	●	24	25	34	174	96	118	56	1	26	SO.. 09T306	4010-M3x8	80-T10	
ATUM 25XD4 SO.. 09T306	●	25	25	34	178	100	122	56	2.25	29.5				
ATUM 27XD4 SO.. 09T306	●	27	25	34	186	108	130	56	1.75	30.5				
ATUM 28XD4 SO.. 09T306	●	28	25	34	190	112	134	56	1.5	31				
ATUM 29XD4 SO.. 09T306	●	29	25	34	194	116	138	56	1.25	31.5	SO.. 120408	4015-M4X11	80-T15	
ATUM 30XD4 SO.. 09T306	●	30	32	44	207	120	147	60	1	32				
ATUM 31XD4 SO.. 09T306	●	31	32	44	211	124	151	60	0.75	32.5				
ATUM 33XD4 SO.. 09T306	●	33	32	44	219	132	159	60	0.5	34				
ATUM 34XD4 SO.. 09T306	●	34	32	44	223	136	163	60	0.25	34.5				
ATUM 35XD4 SO.. 120408	●	35	32	44	227	140	167	60	2.75	40.5				

R: Derecha / Droite / Right L: Izquierda / Gauche / Left

● En Existencia / En stock / In Stock ○ Artículo sin Existencia / Indisponible en Stock / Non Stock Item
 Compatible con el Inserto ISCR. / Compatible avec ISCR Plaquettes. / Compatible with ISCR Insert.

Ejemplo de Pedido / Exemple de Commande / Ordering Example

1 Piezas / pcs. / pcs. ATUM 14XD4 SO.. 050204

Guía del Usuario Para Taladros en U P: 367 / Guide de l'utilisateur Pour U-Drill P: P 367

User's Guide For U-Drills : P 368



Profundidad de Perforación = 2xDiámetro
Profondeur Perçage = 2xDiamètre
Drilling Depth = 2xDiameter

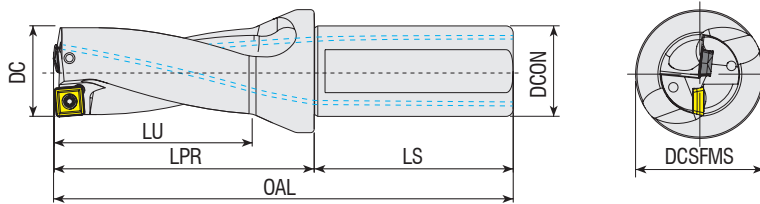

Código del Inserto Le Code de Commande Ordering Code				Stock Stock Stock	Dimension (mm) Dimension (mm) Dimension (mm)				Max. Desplazamiento (radial) Max. Offset (radial) Max. Offset (radial)		Inserto Plaquette Insert	Recambios / Pièces de Rechange / Spare Parts		
					DC	DCON	DCSFMS	OAL	LU	LPR		LS	X _{max}	DC _{max}
ATUM 14XD2	KDR 0502..	●	14	20	25	100	28	50	50	0.25	14.5	SPMT 050204-XOMT 050204	3006-M2x4	80-T06
ATUM 18XD2	KDR 0602..	●	18	25	34	114	36	58	56	0.5	19	SPMT 060205-XOMT 060204	3007-M2.2x5	80-T07
ATUM 20XD2	KDR 07T2..	●	20	25	34	118	40	62	56	0.3	20.6	SPMT 07T208 XOMT 07T205	3008-M2.5x6	80-T08
ATUM 22XD2	KDR 07T2..	●	22	25	34	122	44	66	56	0.3	22.6			
ATUM 24XD2	KDR 0903..	●	24	25	34	126	48	70	56	0.3	24.6	SPMT 090308 XOMT 090305	3008-M3x7	80-T08
ATUM 25XD2	KDR 0903..	●	25	25	34	128	50	72	56	0.3	25.6			
ATUM 26XD2	KDR 0903..	●	26	25	34	130	52	74	56	0.3	26.6	SPMT 11T308 XOMT 11T306	4015-M3.5x9	80-T15
ATUM 28XD2	KDR 0903..	●	28	25	34	134	56	78	56	0.3	28.6			
ATUM 30XD2	KDR 11T3..	●	30	25	34	147	60	87	60	0.35	30.7	SPMT 130410 - XOMT 130406	4015-M4x11	80-T15
ATUM 32XD2	KDR 11T3..	●	32	32	44	151	64	91	60	0.35	32.7			
ATUM 34XD2	KDR 11T3..	●	34	32	44	155	68	95	60	0.35	34.7			
ATUM 37XD2	KDR 1304..	●	37	32	44	161	74	101	60	0.35	37.7			

Compatible con el Inserto KRLY. / Compatible avec KRLY Plaquettes. / Compatible with KRLY Insert.



Profundidad de Perforación = 4xDiámetro
Profondeur Perçage = 4xDiamètre
Drilling Depth = 4xDiameter

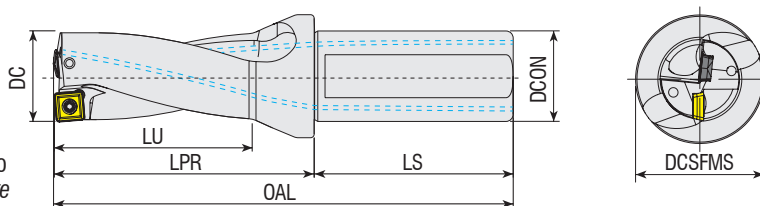

Código del Inserto Le Code de Commande Ordering Code				Stock Stock Stock	Dimension (mm) Dimension (mm) Dimension (mm)				Max. Desplazamiento (radial) Max. Offset (radial) Max. Offset (radial)		Inserto Plaquette Insert	Recambios / Pièces de Rechange / Spare Parts		
					DC	DCON	DCSFMS	OAL	LU	LPR		LS	X _{max}	DC _{max}
ATUM 14XD4	KDR 0502..	●	14	20	25	128	56	78	50	0.25	14.5	SPMT 050204 XOMT 050204	3006-M2x4	80-T06
ATUM 14.5XD4	KDR 0502..	●	14.5	20	25	128	56	78	50	0.25	15			
ATUM 15XD4	KDR 0502..	●	15	20	25	132	60	82	50	0.25	15.5	SPMT 060205 XOMT 060204	3007-M2.2x5	80-T07
ATUM 15.5XD4	KDR 0502..	●	15.5	20	25	132	60	82	50	0.25	16			
ATUM 16XD4	KDR 0502..	●	16	25	34	142	64	86	56	0.25	16.5	SPMT 07T208 XOMT 07T205	3008-M2.5x6	80-T08
ATUM 17XD4	KDR 0602..	●	17	25	34	146	68	90	56	0.5	18			
ATUM 17.5XD4	KDR 0602..	●	17.5	25	34	146	68	90	56	0.5	18.5	SPMT 090308 XOMT 090305	3008-M3x7	80-T08
ATUM 18XD4	KDR 0602..	●	18	25	34	150	72	94	56	0.5	19			
ATUM 18.5XD4	KDR 0602..	●	18.5	25	34	150	72	94	56	0.5	19.5			
ATUM 19XD4	KDR 0602..	●	19	25	34	154	76	98	56	0.5	20	SPMT 090308 XOMT 090305	3008-M3x7	80-T08
ATUM 20XD4	KDR 07T2..	●	20	25	34	158	80	102	56	0.3	20.6			
ATUM 21XD4	KDR 07T2..	●	21	25	34	162	84	106	56	0.3	21.6			
ATUM 22XD4	KDR 07T2..	●	22	25	34	166	88	110	56	0.3	22.6			
ATUM 24XD4	KDR 0903..	●	24	25	34	174	96	118	56	0.3	24.6			
ATUM 25XD4	KDR 0903..	●	25	25	34	178	100	122	56	0.3	25.6			

R: Derecha / Droite / Right L: Izquierda / Gauche / Left

● En Existencia / En stock / In Stock ○ Artículo sin Existencia / Indisponible en Stock / Non Stock Item

Compatible con el Inserto KRLY. / Compatible avec KRLY Plaquettes. / Compatible with KRLY Insert.

Ejemplo de Pedido / Exemple de Commande / Ordering Example

1 Piezas / pcs. / pcs. ATUM 14XD2 KDR.. 0502..

Guía del Usuario Para Taladros en U P: 367 / Guide de l'utilisateur Pour U-Drill P: P 367 / User's Guide For U-Drills : P 368



Profundidad de Perforación = 3xDiámetro
Profondeur Perçage = 3xDiamètre
Drilling Depth = 3xDiameter

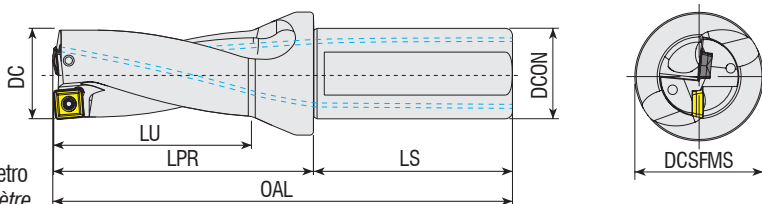

Código del Inserto
Le Code de Commande
Ordering Code

Stock
Stock
Stock

Dimension (mm)
Dimension (mm)
Dimension (mm)

Max. Desplazamiento (radial)
Max. Offset (radial)
Max. Offset (radial)

Inserto
Plaquette
Insert

Recambios / Pièces de Rechange / Spare Parts

Tornillo
Vis
Screw

Llave Torx
Clé Torx
Torx Wrench

Código del Inserto Le Code de Commande Ordering Code	Stock Stock Stock	DC	DCON	DCSFMS	OAL	LU	LPR	LS	Max. Desplazamiento (radial) Max. Offset (radial) Max. Offset (radial)		Inserto Plaquette Insert	Tornillo Vis Screw	Llave Torx Clé Torx Torx Wrench
									X _{max} X _{max} [mm]	DC _{max} DC _{max} [mm]			
ATUM 12.5XD3 KDR 0402..	●	12.5	20	25	108	36	58	50	0.2	12.9	SPMT 040204 XOMT 040204		
ATUM 13XD3 KDR 0402..	●	13	20	25	111	39	61	50	0.2	13.4			
ATUM 14XD3 KDR 0502..	●	14	20	25	114	42	64	50	0.25	14.5			
ATUM 14.5XD3 KDR 0502..	●	14.5	20	25	114	42	64	50	0.25	15	SPMT 050204 XOMT 050204	3006-M2x4	80-T06
ATUM 15XD3 KDR 0502..	●	15	20	25	117	45	67	50	0.25	15.5			
ATUM 15.5XD3 KDR 0502..	●	15.5	20	25	117	45	67	50	0.25	16			
ATUM 16XD3 KDR 0502..	●	16	25	34	126	48	70	56	0.25	16.5			
ATUM 16.5XD3 KDR 0602..	●	16.5	25	34	126	48	70	56	0.5	17.5			
ATUM 17XD3 KDR 0602..	●	17	25	34	129	51	73	56	0.5	18			
ATUM 17.5XD3 KDR 0602..	●	17.5	25	34	129	51	73	56	0.5	18.5			
ATUM 18XD3 KDR 0602..	●	18	25	34	132	54	76	56	0.5	19	SPMT 060205 XOMT 060204	3007-M2.2x5	80-T07
ATUM 18.5XD3 KDR 0602..	●	18.5	25	34	132	54	76	56	0.5	19.5			
ATUM 19XD3 KDR 0602..	●	19	25	34	135	57	79	56	0.5	20			
ATUM 19.5XD3 KDR 0602..	●	19.5	25	34	135	57	79	56	0.5	20.5			
ATUM 20XD3 KDR 07T2..	●	20	25	34	138	60	82	56	0.3	20.6			
ATUM 20.5XD3 KDR 07T2..	●	20.5	25	34	138	60	82	56	0.3	21.1			
ATUM 21XD3 KDR 07T2..	●	21	25	34	141	63	85	56	0.3	21.6	SPMT 07T208 XOMT 07T205	3008-M2.5x6	
ATUM 22XD3 KDR 07T2..	●	22	25	34	144	66	88	56	0.3	22.6			
ATUM 23XD3 KDR 07T2..	●	23	25	34	147	69	91	56	0.3	23.6			
ATUM 23.5XD3 KDR 07T2..	●	23.5	25	34	147	69	91	56	0.3	24.1			
ATUM 24XD3 KDR 0903..	●	24	25	34	150	72	94	56	0.3	24.6			80-T08
ATUM 24.5XD3 KDR 0903..	●	24.5	25	34	150	72	94	56	0.3	25.1			
ATUM 25XD3 KDR 0903..	●	25	25	34	153	75	97	56	0.3	25.6			
ATUM 26XD3 KDR 0903..	●	26	25	34	156	78	100	56	0.3	26.6	SPMT 090308 XOMT 090305	3008-M3x7	
ATUM 27XD3 KDR 0903..	●	27	25	34	159	81	103	56	0.3	27.6			
ATUM 28XD3 KDR 0903..	●	28	25	34	162	84	106	56	0.3	28.6			
ATUM 29XD3 KDR 0903..	●	29	25	34	165	87	109	56	0.3	29.6			
ATUM 30XD3 KDR 11T3..	●	30	32	44	177	90	117	60	0.35	30.7			
ATUM 32XD3 KDR 11T3..	●	32	32	44	183	96	123	60	0.35	32.7			
ATUM 33XD3 KDR 11T3..	●	33	32	44	186	99	126	60	0.35	33.7	SPMT 11T308 XOMT 11T306	4015-M3.5x9	
ATUM 34XD3 KDR 11T3..	●	34	32	44	189	102	129	60	0.35	34.7			
ATUM 35XD3 KDR 11T3..	●	35	32	44	192	105	132	60	0.35	35.7			80-T15
ATUM 37XD3 KDR 1304..	●	37	32	44	198	111	138	60	0.35	37.7			
ATUM 38XD3 KDR 1304..	●	38	32	44	201	114	141	60	0.35	38.7	SPMT 130410 XOMT 130406	4015-M4x11	
ATUM 39XD3 KDR 1304..	●	39	32	44	204	117	144	60	0.35	39.7			
ATUM 40XD3 KDR 1304..	●	40	32	44	207	120	147	60	0.35	40.7			

R: Derecha / Droite / Right L: Izquierda / Gauche / Left

● En Existencia / En stock / In Stock ○ Artículo sin Existencia / Indisponible en Stock / Non Stock Item
Compatible con el Inserto KRLY. / Compatible avec KRLY Plaquettes. / Compatible with KRLY Insert.

Ejemplo de Pedido / Exemple de Commande / Ordering Example

1 Piezas / pcs. / pcs. ATUM 12.5XD3 KDR 0402..

Guía del Usuario Para Taladros en U P: 367 / Guide de l'utilisateur Pour U-Drills P: P 367

User's Guide For U-Drills : P 368



Profundidad de Perforación = 2xDiámetro
Profondeur Perçage = 2xDiamètre
Drilling Depth = 2xDiameter

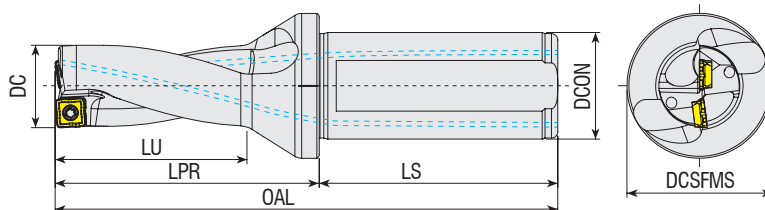

Código del Inserto Le Code de Commande Ordering Code	Stock Stock Stock	Dimension (mm) Dimension (mm) Dimension (mm)								Max. Desplazamiento (radial) Max. Offset (radial) Max. Offset (radial)	Inserto Plaquette Insert	Recambios / Pièces de Rechange / Spare Parts	
		DC	DCON	DCSFMS	OAL	LU	LPR	LS	Tornillo Vis Screw			Llave Torx Clé Torx Torx Wrench	
ATUM 14XD2 SOMT 050204	●	14	20	25	100	28	50	50	0.5	15	SOMT 050204	3006-M2x4	80-T06
ATUM 16XD2 SOMT 050204	●	16	25	34	110	32	54	56	0.3	16.6	SOMT 060204	3007-M2.2x5	80-T07
ATUM 17XD2 SOMT 060204	●	17	25	34	112	34	56	56	0.5	18			
ATUM 18XD2 SOMT 060204	●	18	25	34	114	36	58	56	0.4	18.8	SOMT 070306	3008-M2.5x6	80-T08
ATUM 20XD2 SOMT 070306	●	20	25	34	118	40	62	56	0.5	21			
ATUM 22XD2 SOMT 070306	●	22	25	34	122	44	66	56	0.3	22.6	SOMT 08T306	4015-M3.5x9	80-T15
ATUM 23XD2 SOMT 08T306	●	23	25	34	124	46	68	56	0.5	24			
ATUM 24XD2 SOMT 08T306	●	24	25	34	126	48	70	56	0.5	25	SOMT 09T308	4015-M4x11	80-T20
ATUM 25XD2 SOMT 08T306	●	25	25	34	128	50	72	56	0.4	25.8			
ATUM 26XD2 SOMT 08T306	●	26	25	34	130	52	74	56	0.3	26.6	SOMT 11T308	1020-M5x11	80-T20
ATUM 27XD2 SOMT 09T308	●	27	25	34	132	54	76	56	0.5	28			
ATUM 28XD2 SOMT 09T308	●	28	25	34	134	56	78	56	0.5	29	SOMT 130408	1020-M5x11	80-T20
ATUM 29XD2 SOMT 09T308	●	29	25	34	136	58	80	56	0.5	30			
ATUM 30XD2 SOMT 09T308	●	30	32	44	147	60	87	60	0.5	31	SOMT 150510	1020-M5x11	80-T20
ATUM 32XD2 SOMT 11T308	●	32	32	44	151	64	91	60	0.5	33			
ATUM 33XD2 SOMT 11T308	●	33	32	44	153	66	93	60	0.5	34	SOMT 150510	1020-M5x11	80-T20
ATUM 34XD2 SOMT 11T308	●	34	32	44	155	68	95	60	0.5	35			
ATUM 35XD2 SOMT 11T308	●	35	32	44	157	70	97	60	0.5	36	SOMT 150510	1020-M5x11	80-T20
ATUM 37XD2 SOMT 130408	●	37	32	44	161	74	101	60	0.5	38			
ATUM 38XD2 SOMT 130408	●	38	32	44	163	76	103	60	0.5	39	SOMT 150510	1020-M5x11	80-T20
ATUM 40XD2 SOMT 130408	●	40	32	44	167	80	107	60	0.5	41			
ATUM 45XD2 SOMT 150510	●	45	40	54	192	90	122	70	0.5	46	SOMT 150510	1020-M5x11	80-T20
ATUM 47XD2 SOMT 150510	●	47	40	54	196	94	126	70	0.5	48			

R: Derecha / Droite / Right L: Izquierda / Gauche / Left

● En Existencia / En stock / In Stock ○ Artículo sin Existencia / Indisponible en Stock / Non Stock Item
Compatible con el Inserto TGTC. / Compatible avec TGTC Plaquettes. / Compatible with TGTC Insert.

Ejemplo de Pedido / Exemple de Commande / Ordering Example

1 Piezas / pcs. / pcs. ATUM 14XD2 SOMT 050204

Guía del Usuario Para Taladros en U P: 367 / Guide de l'utilisateur Pour U-Drill P: 367

User's Guide For U-Drills : P 368



Profundidad de Perforación = 3xDiámetro
 Profondeur Perçage = 3xDiamètre
 Drilling Depth = 3xDiameter

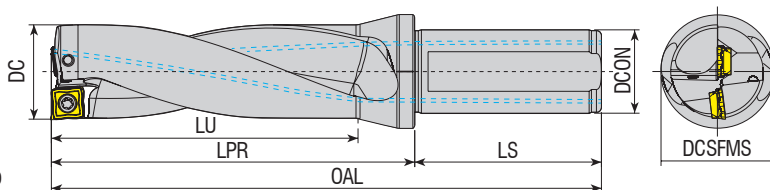

Código del Inserto Le Code de Commande Ordering Code	Stock Stock Stock	Dimension (mm) Dimension (mm) Dimension (mm)							Max. Desplazamiento (radial) Max. Offset (radial) Max. Offset (radial)		Inserto Plaquette Insert	Recambios / Pièces de Rechange / Spare Parts	
		DC	DCON	DCSFMS	OAL	LU	LPR	LS	X _{max} [mm]	DC _{max} [mm]		Tornillo Vis Screw	Llave Torx Clé Torx Torx Wrench
ATUM 14XD3 SOMT 050204	●	14	20	25	114	42	64	50	0.5	15	SOMT 050204	3006-M2x4	80-T06
ATUM 14.5XD3 SOMT 050204	●	14.5	20	25	114	42	64	50	0.4	15.3			
ATUM 15XD3 SOMT 050204	●	15	20	25	117	45	67	50	0.4	15.8			
ATUM 15.5XD3 SOMT 050204	●	15.5	20	25	117	45	67	50	0.3	16.1			
ATUM 16XD3 SOMT 050204	●	16	25	34	126	48	70	56	0.3	16.6	SOMT 060204	3007-M2.2x5	80-T07
ATUM 16.5XD3 SOMT 060204	●	16.5	25	34	126	48	70	56	0.5	17.5			
ATUM 17XD3 SOMT 060204	●	17	25	34	129	51	73	56	0.5	18			
ATUM 17.5XD3 SOMT 060204	●	17.5	25	34	129	51	73	56	0.4	18.3			
ATUM 18XD3 SOMT 060204	●	18	25	34	132	54	76	56	0.4	18.8	SOMT 070306	3008-M2.5x6	80-T08
ATUM 18.5XD3 SOMT 060204	●	18.5	25	34	132	54	76	56	0.3	19.1			
ATUM 19XD3 SOMT 060204	●	19	25	34	135	57	79	56	0.3	19.6			
ATUM 19.5XD3 SOMT 070306	●	19.5	25	34	135	57	79	56	0.5	20.5			
ATUM 20XD3 SOMT 070306	●	20	25	34	138	60	82	56	0.5	21	SOMT 08T306	4015-M3.5x9	80-T15
ATUM 20.5XD3 SOMT 070306	●	20.5	25	34	138	60	82	56	0.4	21.3			
ATUM 21XD3 SOMT 070306	●	21	25	34	141	63	85	56	0.4	21.8			
ATUM 21.5XD3 SOMT 070306	●	21.5	25	34	141	63	85	56	0.3	22.6			
ATUM 22XD3 SOMT 070306	●	22	25	34	144	66	88	56	0.5	23.5	SOMT 09T308	4015-M4x11	80-T20
ATUM 22.5XD3 SOMT 08T306	●	22.5	25	34	144	66	88	56	0.5	24			
ATUM 23XD3 SOMT 08T306	●	23	25	34	147	69	91	56	0.5	24.5			
ATUM 23.5XD3 SOMT 08T306	●	23.5	25	34	147	69	91	56	0.5	25			
ATUM 24XD3 SOMT 08T306	●	24	25	34	150	72	94	56	0.5	25.3	SOMT 11T308	1020-M5x11	80-T20
ATUM 24.5XD3 SOMT 08T306	●	24.5	25	34	150	72	94	56	0.4	25.8			
ATUM 25XD3 SOMT 08T306	●	25	25	34	153	75	97	56	0.4	26.6			
ATUM 25.5XD3 SOMT 08T306	●	25.5	25	34	153	75	97	56	0.3	28			
ATUM 26XD3 SOMT 08T306	●	26	25	34	156	78	100	56	0.3	28	SOMT 130408	4015-M4x11	80-T15
ATUM 27XD3 SOMT 09T308	●	27	25	34	159	81	103	56	0.5	27.5			
ATUM 27.5XD3 SOMT 09T308	●	27.5	25	34	159	81	103	56	0.5	29			
ATUM 28XD3 SOMT 09T308	●	28	25	34	162	84	106	56	0.5	29			
ATUM 28.5XD3 SOMT 09T308	●	28.5	25	34	162	84	106	56	0.5	30	SOMT 150510	1020-M5x11	80-T20
ATUM 29XD3 SOMT 09T308	●	29	25	34	165	87	109	56	0.5	31			
ATUM 29.5XD3 SOMT 09T308	●	29.5	25	34	165	87	109	56	0.5	33			
ATUM 30XD3 SOMT 09T308	●	30	32	44	177	90	117	60	0.5	34			
ATUM 30.5XD3 SOMT 09T308	●	30.5	32	44	177	90	117	60	0.5	35	SOMT 130408	4015-M4x11	80-T15
ATUM 31XD3 SOMT 09T308	●	31	32	44	183	96	123	60	0.5	36			
ATUM 32XD3 SOMT 11T308	●	32	32	44	183	96	123	60	0.5	36.8			
ATUM 32.5XD3 SOMT 11T308	●	32.5	32	44	183	96	123	60	0.4	38			
ATUM 33XD3 SOMT 11T308	●	33	32	44	186	99	126	60	0.5	38	SOMT 130408	4015-M4x11	80-T15
ATUM 33.5XD3 SOMT 11T308	●	33.5	32	44	186	99	126	60	0.5	39			
ATUM 34XD3 SOMT 11T308	●	34	32	44	189	102	129	60	0.5	40			
ATUM 34.5XD3 SOMT 11T308	●	34.5	32	44	189	102	129	60	0.5	41			
ATUM 35XD3 SOMT 11T308	●	35	32	44	192	105	132	60	0.5	41	SOMT 150510	1020-M5x11	80-T20
ATUM 35.5XD3 SOMT 11T308	●	35.5	32	44	192	105	132	60	0.5	46			
ATUM 36XD3 SOMT 11T308	●	36	32	44	195	108	135	60	0.4	46			
ATUM 36.5XD3 SOMT 11T308	●	36.5	32	44	195	108	135	60	0.4	46			
ATUM 37XD3 SOMT 130408	●	37	32	44	198	111	138	60	0.5	46	SOMT 150510	1020-M5x11	80-T20
ATUM 37.5XD3 SOMT 130408	●	37.5	32	44	198	111	138	60	0.5	46			
ATUM 38XD3 SOMT 130408	●	38	32	44	201	114	141	60	0.5	50			
ATUM 38.5XD3 SOMT 130408	●	38.5	32	44	201	114	141	60	0.5	50			
ATUM 39XD3 SOMT 130408	●	39	32	44	204	117	144	60	0.5	50	SOMT 150510	1020-M5x11	80-T20
ATUM 39.5XD3 SOMT 130408	●	39.5	32	44	204	117	144	60	0.5	50			
ATUM 40XD3 SOMT 130408	●	40	32	44	207	120	147	60	0.5	51			
ATUM 40.5XD3 SOMT 130408	●	40.5	32	44	207	120	147	60	0.5	51			
ATUM 45XD3 SOMT 150510	●	45	40	54	237	135	167	70	0.5	46	SOMT 150510	1020-M5x11	80-T20
ATUM 45.5XD3 SOMT 150510	●	45.5	40	54	237	135	167	70	0.5	46			
ATUM 49XD3 SOMT 150510	●	49	40	54	249	147	179	70	0.5	50			
ATUM 49.5XD3 SOMT 150510	●	49.5	40	54	249	147	179	70	0.5	50			
ATUM 50XD3 SOMT 150510	●	50	40	54	252	150	182	70	0.5	51	SOMT 150510	1020-M5x11	80-T20
ATUM 50.5XD3 SOMT 150510	●	50.5	40	54	252	150	182	70	0.5	51			
ATUM 51XD3 SOMT 150510	●	51	40	54	255	153	185	70	0.5	51			
ATUM 51.5XD3 SOMT 150510	●	51.5	40	54	255	153	185	70	0.5	51			

R: Derecha / Droite / Right L: Izquierda / Gauche / Left

● En Existencia / En stock / In Stock ○ Artículo sin Existencia / Indisponible en Stock / Non Stock Item
 Compatible con el Inserto TGTC. / Compatible avec TGTC Plaquettes. / Compatible with TGTC Insert.

Ejemplo de Pedido / Exemple de Commande / Ordering Example

1 Piezas / pcs. / pcs. ATUM 14XD3 SOMT 050204

Guía del Usuario Para Taladros en U P: 367 / Guide de l'utilisateur Pour U-Drill P: P 367

User's Guide For U-Drills : P 368



Profundidad de Perforación = 4xDiámetro
 Profondeur Perçage = 4xDiamètre
 Drilling Depth = 4xDiameter

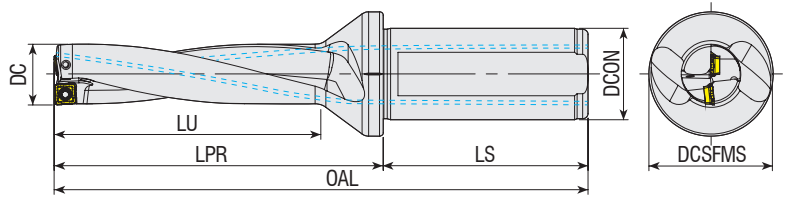

Código del Inserto Le Code de Commande Ordering Code	Stock Stock Stock	Dimension (mm) Dimension (mm) Dimension (mm)								Max. Desplazamiento (radial) Max. Offset (radial) Max. Offset (radial)	Inserto Plaquette Insert	Recambios / Pièces de Rechange / Spare Parts	
		DC	DCON	DCSFMS	OAL	LU	LPR	LS	Tornillo Vis Screw			Llave Torx Clé Torx Torx Wrench	
ATUM 14XD4 SOMT 050204	●	14	20	25	128	56	78	50	0.5	15	SOMT 050204	3006-M2x4	80-T06
ATUM 14.5XD4 SOMT 050204	●	14.5	20	25	128	56	78	50	0.4	15.3			
ATUM 16XD4 SOMT 050204	●	16	25	34	142	64	86	56	0.3	16.6			
ATUM 17XD4 SOMT 060204	●	17	25	34	146	68	90	56	0.5	18	SOMT 060204	3007-M2.2x5	80-T07
ATUM 17.5XD4 SOMT 060204	●	17.5	25	34	146	68	90	56	0.4	18.3			
ATUM 18XD4 SOMT 060204	●	18	25	34	150	72	94	56	0.4	18.8			
ATUM 19XD4 SOMT 060204	●	19	25	34	154	76	98	56	0.3	19.6			
ATUM 20XD4 SOMT 070306	●	20	25	34	158	80	102	56	0.5	21	SOMT 070306		
ATUM 21XD4 SOMT 070306	●	21	25	34	162	84	106	56	0.4	21.8			
ATUM 22XD4 SOMT 070306	●	22	25	34	166	88	110	56	0.3	22.6	SOMT 08T306	3008-M2.5x6	80-T08
ATUM 24XD4 SOMT 08T306	●	24	25	34	174	96	118	56	0.5	25			
ATUM 25XD4 SOMT 08T306	●	25	25	34	178	100	122	56	0.4	25.8			

R: Derecha / Droite / Right L: Izquierda / Gauche / Left
 ● En Existencia / En stock / In Stock ○ Artículo sin Existencia / Indisponible en Stock / Non Stock Item
 Compatible con el Inserto TGTC. / Compatible avec TGTC Plaquettes. / Compatible with TGTC Insert.

Ejemplo de Pedido / Exemple de Commande / Ordering Example
 1 Piezas / pcs. / pcs. ATUM 14XD4 SOMT 050204
 Guía del Usuario Para Taladros en U P: 367 / Guide de l'utilisateur Pour U-Drill P: P 367
 User's Guide For U-Drills : P 368





Profundidad de Perforación = 5xDiámetro
 Profondeur Perçage = 5xDiámetro
 Drilling Depth = 5xDiameter

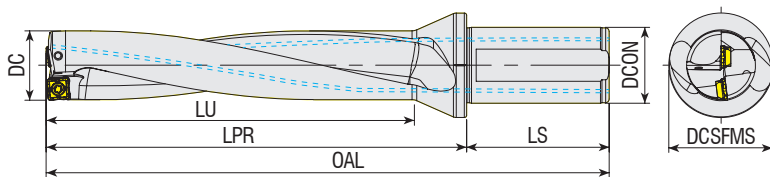

Código del Inserto Le Code de Commande Ordering Code	Stock Stock Stock	Dimension (mm) Dimension (mm) Dimension (mm)								Max. Desplazamiento (radial) Max. Offset (radial) Max. Offset (radial)	Inserto Plaquette Insert	Recambios / Pièces de Rechange / Spare Parts	
		DC	DCON	DCSFMS	OAL	LU	LPR	LS	Tornillo Vis Screw			Llave Torx Clé Torx Torx Wrench	
ATUM 14XD5 SOMT 050204	●	14	20	25	142	70	92	50	0.5	15	SOMT 050204	3006-M2x4	80-T06
ATUM 15XD5 SOMT 050204	●	15	20	25	147	75	97	50	0.4	15.8			
ATUM 15.5XD5 SOMT 050204	●	15.5	20	25	147	75	97	50	0.3	16.1			
ATUM 16XD5 SOMT 050204	●	16	25	34	158	80	102	56	0.3	16.6	SOMT 060204	3007-M2.2x5	80-T07
ATUM 16.5XD5 SOMT 060204	●	16.5	25	34	158	80	102	56	0.5	17.5			
ATUM 17.5XD5 SOMT 060204	●	17.5	25	34	163	85	107	56	0.4	18.3			
ATUM 18XD5 SOMT 060204	●	18	25	34	168	90	112	56	0.4	18.8	SOMT 070306	3008-M2.5x6	80-T08
ATUM 18.5XD5 SOMT 060204	●	18.5	25	34	168	90	112	56	0.3	19.1			
ATUM 19XD5 SOMT 060204	●	19	25	34	173	95	117	56	0.3	19.6			
ATUM 19.5XD5 SOMT 070306	●	19.5	25	34	173	95	117	56	0.5	20.5	SOMT 08T306	4015-M3.5x9	80-T15
ATUM 20XD5 SOMT 070306	●	20	25	34	178	100	122	56	0.5	21			
ATUM 21XD5 SOMT 070306	●	21	25	34	183	105	127	56	0.4	21.8			
ATUM 22XD5 SOMT 070306	●	22	25	34	188	110	132	56	0.3	22.6	SOMT 09T308	80-T15	
ATUM 23XD5 SOMT 08T306	●	23	25	34	193	115	137	56	0.5	24			
ATUM 24XD5 SOMT 08T306	●	24	25	34	198	120	142	56	0.5	25			
ATUM 25XD5 SOMT 08T306	●	25	25	34	203	125	147	56	0.4	25.8	SOMT 11T308	80-T15	
ATUM 26XD5 SOMT 08T306	●	26	25	34	208	130	152	56	0.3	26.6			
ATUM 27XD5 SOMT 09T308	●	27	25	34	213	135	157	56	0.5	28			
ATUM 28XD5 SOMT 09T308	●	28	25	34	218	140	162	56	0.5	29	SOMT 11T308	80-T15	
ATUM 29XD5 SOMT 09T308	●	29	25	34	223	145	167	56	0.5	30			
ATUM 30XD5 SOMT 09T308	●	30	32	44	237	150	177	60	0.5	31			
ATUM 33XD5 SOMT 11T308	●	33	32	44	252	165	192	60	0.5	34	SOMT 11T308	80-T15	
ATUM 34XD5 SOMT 11T308	●	34	32	44	257	170	197	60	0.5	35			
ATUM 35XD5 SOMT 11T308	●	35	32	44	262	175	202	60	0.5	36			
ATUM 36XD5 SOMT 11T308	●	36	32	44	267	180	207	60	0.4	36.8			

R: Derecha / Droite / Right L: Izquierda / Gauche / Left
 ● En Existencia / En stock / In Stock ○ Artículo sin Existencia / Indisponible en Stock / Non Stock Item
 Compatible con el Inserto TGTC. / Compatible avec TGTC Plaquettes. / Compatible with TGTC Insert.

Ejemplo de Pedido / Exemple de Commande / Ordering Example
 1 Piezas / pcs. / pcs. ATUM 14XD5 SOMT 050204
 Guía del Usuario Para Taladros en U P: 367 / Guide de l'utilisateur Pour U-Drill P: P 367
 User's Guide For U-Drills : P 368



Bohrtiefe = 3xDurchmesser
 Profondità di Foratura = 3xDiametro
 Drilling Depth = 3xDiameter

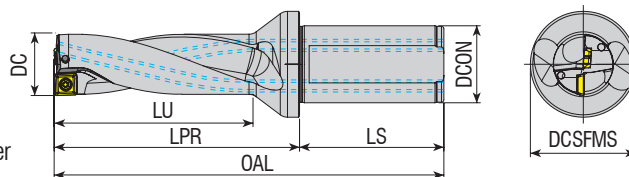

Código del Inserto Le Code de Commande Ordering Code	Stock Stock Stock	Dimension (mm) Dimension (mm) Dimension (mm)								Max. Desplazamiento (radial) Max. Offset (radial) Max. Offset (radial)		Inserto Plaquette Insert	Recambios / Pièces de Rechange / Spare Parts	
		DC	DCON	DCSFMS	OAL	LU	LPR	LS	X _{max} X _{max} [mm]	DC _{max} DC _{max} [mm]	Tornillo Vis Screw		Llave Torx Cle Torx Torx Wrench	
ATUM 14XD3 880-0202..	●	14	20	25	108	42	58	50	0.5	15	880-02...C/P	3006-M2x4	80-T06	
ATUM 14.5XD3 880-0202..	●	14.5	20	25	110	46	60	50	0.45	15.4				
ATUM 15XD3 880-0202..	●	15	20	25	112	48	62	50	0.4	15.8				
ATUM 15.5XD3 880-0202..	●	15.5	20	25	114	50	64	50	0.3	16.1				
ATUM 16XD3 880-0202..	●	16	20	25	116	51	66	50	0.3	16.6				
ATUM 16.5XD3 880-0303..	●	16.5	20	25	118	53	68	50	0.6	17.7				
ATUM 17XD3 880-0303..	●	17	20	25	119	54	69	50	0.6	18.2				
ATUM 17.5XD3 880-0303..	●	17.5	25	32	128	56	72	56	0.5	18.5				
ATUM 18XD3 880-0303..	●	18	25	32	129	57	73	56	0.4	18.8				
ATUM 18.5XD3 880-0303..	●	18.5	25	32	131	59	75	56	0.4	19.3				
ATUM 19XD3 880-0303..	●	19	25	32	132	60	76	56	0.3	19.6				
ATUM 19.5XD3 880-0303..	●	19.5	25	32	135	62	79	56	0.3	20.1				
ATUM 20XD3 880-0403..	●	20	25	32	137	64	81	56	0.9	21.8				
ATUM 20.5XD3 880-0403..	●	20.5	25	32	138	65	82	56	0.8	22.1				
ATUM 21XD3 880-0403..	●	21	25	32	140	66	84	56	0.8	22.6				
ATUM 21.5XD3 880-0403..	●	21.5	25	32	142	68	86	56	0.7	22.9				
ATUM 22XD3 880-0403..	●	22	25	32	143	69	87	56	0.6	23.2				
ATUM 22.5XD3 880-0403..	●	22.5	25	32	146	71	90	56	0.5	23.5				
ATUM 23XD3 880-0403..	●	23	25	32	147	72	91	56	0.5	24				
ATUM 24XD3 880-0503..	●	24	25	32	151	76	95	56	1.1	26.2				
ATUM 25XD3 880-0503..	●	25	25	32	155	79	99	56	1	27				
ATUM 26XD3 880-0503..	●	26	32	44	162	81	102	60	0.9	27.8				
ATUM 27XD3 880-0503..	●	27	32	44	165	84	105	60	0.7	28.4				
ATUM 28XD3 880-0503..	●	28	32	44	169	87	109	60	0.6	29.2				
ATUM 29XD3 880-0503..	●	29	32	44	172	90	112	60	0.5	30				
ATUM 30XD3 880-0604..	●	30	32	44	177	94	117	60	1.1	32.2				
ATUM 31XD3 880-0604..	●	31	40	54	191	97	121	70	1	33				
ATUM 32XD3 880-0604..	●	32	40	54	194	100	124	70	0.9	33.8				
ATUM 33XD3 880-0604..	●	33	40	54	198	103	128	70	0.7	34.4				
ATUM 34XD3 880-0604..	●	34	40	54	201	106	131	70	0.5	35				
ATUM 35XD3 880-0604..	●	35	40	54	205	109	135	70	0.4	35.8				
ATUM 36XD3 880-0704..	●	36	40	54	209	112	139	70	1.3	38.6				
ATUM 38XD3 880-0704..	●	38	40	54	216	118	146	70	1.1	40.2				
ATUM 39XD3 880-0704..	●	39	40	54	219	121	149	70	1	41				
ATUM 40XD3 880-0704..	●	40	40	54	223	124	153	70	0.8	41.6				
ATUM 41XD3 880-0704..	●	41	40	54	227	127	157	70	0.7	42.4				
ATUM 42XD3 880-0704..	●	42	40	54	230	130	160	70	0.6	43.2				
ATUM 45XD3 880-0805..	●	45	40	54	242	140	172	70	1.4	47.8				
ATUM 46XD3 880-0805..	●	46	40	54	246	143	176	70	1.3	48.6				
ATUM 48XD3 880-0805..	●	48	40	54	253	149	183	70	1	50				
ATUM 50XD3 880-0805..	●	50	40	54	260	155	190	70	0.8	51.6				

R: Derecha / Droite / Right L: Izquierda / Gauche / Left

● En Existencia / En stock / In Stock ○ Artículo sin Existencia / Indisponible en Stock / Non Stock Item
 Kompatibel mit SNDVK Wendepplatten. / Compatible con Inserti SNDVK. / Compatible with SNDVK Insert.

Ejemplo de Pedido / Exemple de Commande / Ordering Example

1 Piezas / pcs. / pcs. ATUM 14XD3 880-0202..

Guía del Usuario Para Taladros en U P: 367 / Guide de l'utilisateur Pour U-Drill P: 367

User's Guide For U-Drills : P 368

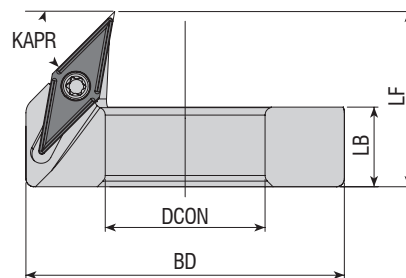

Código del Inserto
Le Code de Commande
Ordering Code

Stock Stock Stock	Dimension (mm) Dimension (mm) Dimension (mm)				Diámetro ATUM compatible Compatible ATUM Diamètre Compatible ATUM Diameter	Recambios / Pièces de Rechange / Spare Parts				
	BD	DCON	LB	LF		ATUM Ø	Inserto Plaquette Insert	Tornillo Vis Screw	Llave Torx Clé Torx Torx Wrench	Tornillo de Fijación Vis de Fixation Mounting Screw
●	32	12	10	22	12.5	VB.T 1103..	4008-M2.5x6	80-T08	AAV-14-M5x14	AAL-03-3
●	32.5	12.5	10	22	13					
●	33	13	10	22	13.5					
●	33.5	13.5	10	22	14					
●	34	14	10	22	14.5					
●	34.5	14.5	10	22	15					
●	35	15	10	22	15.5 -16					
●	35.5	15.5	10	22	16.5					
●	36	16	10	22	17					
●	36.5	16.5	10	22	17.5					
●	37	17	10	22	18					
●	37.5	17.5	10	22	18.5					
●	38	18	10	22	19					
●	38.5	18.5	10	22	19.5					
●	39	19	10	22	20					
●	39.5	19.5	10	22	20.5					
●	40	20	10	22	21					
●	40.5	20.5	10	22	21.5					
●	41	21	10	22	22					
●	41.5	21.5	10	22	22.5					
●	42	22	10	22	23					
●	42.5	22.5	10	22	23.5					
●	43	23	10	22	24					
●	43.5	23.5	10	22	24.5					
●	44	24	10	22	25					
●	44.5	24.5	10	22	25.5					
●	45	25	10	22	26					
●	45.5	25.5	10	22	26.5					
●	46	26	10	22	27					
●	46.5	26.5	10	22	27.5					
●	47	27	10	22	28					
●	47.5	27.5	10	22	28.5					
●	48	28	10	22	29					
●	48.5	28.5	10	22	29.5					
●	49	29	10	22	30					
●	49.5	29.5	10	22	30.5					
●	50	30	10	22	31					

R: Derecha / Droite / Right L: Izquierda / Gauche / Left

● En Existencia / En stock / In Stock ○ Artículo sin Existencia / Indisponible en Stock / Non Stock Item
 Compatible con el Inserto ISO. / Compatible avec ISO Plaquettes. / Compatible with ISO Insert.

Ejemplo de Pedido / Exemple de Commande / Ordering Example

1 Piezas / pcs. / pcs. ADCR-120-VB1103

Guía del Usuario Para Taladros en U P: 367 / Guide de l'utilisateur Pour U-Drill P: P 367

User's Guide For U-Drills : P 368



Recomendado / Conseillé / Recommended

A

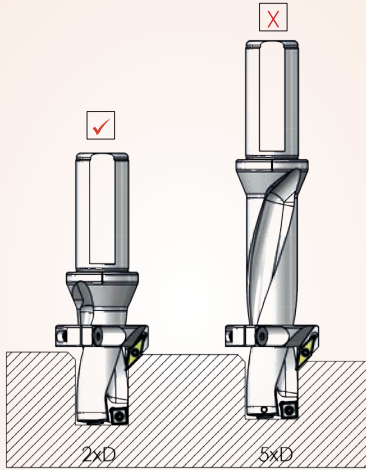

Si es posible, utilícelo siempre con herramientas de perforación cortas. De lo contrario, reduzca sus velocidades para minimizar la vibración.

Si possible, utiliser des outils de forage toujours court. Dans le cas contraire, réduire votre vitesse pour minimiser les vibrations.

Always use short drilling tools, if not possible reduce the cutting speed to minimize the vibration.

B

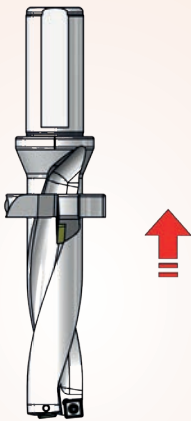

Acérquese lo más posible al eje de montaje del anillo de achaflanado.

Rapprochez de l'arbre de montage de la bague de chanfreinage possible.

Mount the chamfering ring as close as possible to the shaft.

C

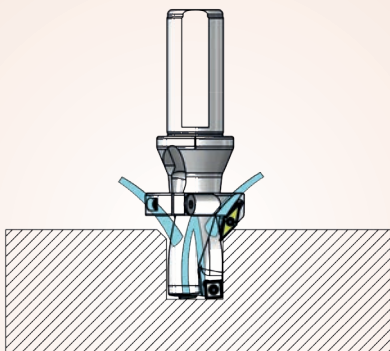

Aplique enfriamiento externo y taladro de refrigerante interno para una mejor vida útil de los insertos.

Appliquer le refroidissement Extérieur et forage de refroidissement interieur pour une vie meilleure pour les plaquettes.

For better insert live apply external coolant and drill insert internal coolant.

Sistema de Montaje / Système de Montage / Mounting System

1



Coloque el anillo de achaflanado para perforar el cuerpo.

Mettez l'anneau chanfreinage au corps de forage.

Insert the chamfering ring on the drill body.

2

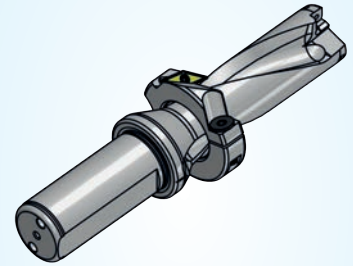

Deslice el anillo de achaflanado a la posición deseada.

S'il vous plaît coulisser bague chanfreinage dans la position souhaitée.

Slide chamfering ring to the desired position.

3

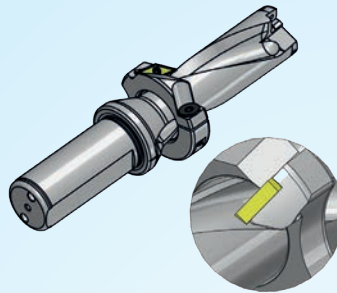

Mantenga la posición del anillo de achaflanado que no resistirá a las virutas fluidas e intente ser igual a los puntos de inicio de la hélice.

S'il vous plaît garder la position de l'anneau chanfreinage qui ne résistera pas à fluiding puces et essayer d'être égal aux points de départ de l'hélice. Make sure the chamfering ring is matching the helix start and not preventing the chip flow.

4

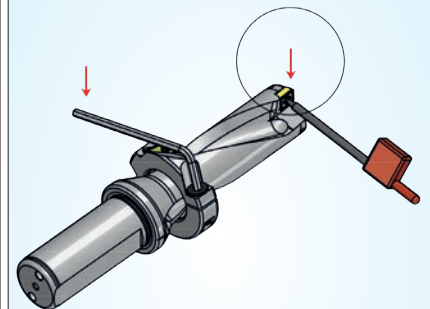

Apriete el anillo de achaflanado y coloque la broca.

Serrage de la bague biseautage et de mettre l'plaque de forage.

Tightening the ring's screw and mount the drill's inserts.

Correcta instalación de los anillos de achaflanado.

Une installation correcte des anneaux chanfering.

Proper installation of chamfering rings.

✓

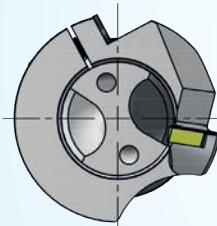

✗

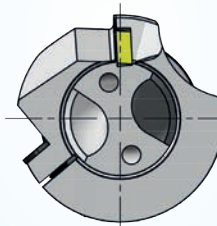

✗

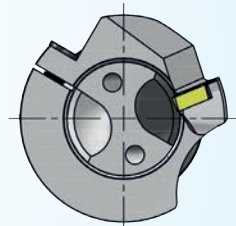

ADAPTADOR ECCENTRICO PARA TALADROS EN U- DRILL
ADAPTEUR EXCENTRIQUE POUR U-DRILL
ECCENTRIC ADAPTOR FOR U-DRILLS

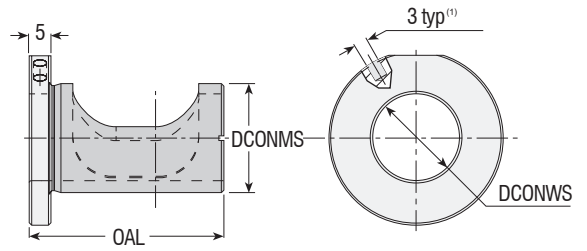

Código del Inserto Le Code de Commande Ordering Code	Stock Stock Stock	Dimension (mm) Dimension (mm) Dimension (mm)		
		DCON	BD	LF
AET-2025	●	20	25	44
AET-2532	●	25	32	46
AET-3240	●	32	40	55

■ (1) Orificios para insertar un pasador, utilizados para facilitar el ajuste radial del manguito (pasador no suministrado). / Des trous pour l'ajustement d'une broche, qui sert à faciliter l'ajustement radial du manchon (broche non fourni).
 The hole is used to make an easier adjustment of the adapter, with the help of a thin metal pin.

En una fresadora, el diámetro nominal del taladro se puede cambiar desplazando el eje del taladro fuera del eje de la herramienta.

Sur une machine de fraisage diamètre nominal de la perceuse peut être modifiée en déplaçant l'axe de l'exercice de la broche d'outil.

In milling machines, the diameter of the insert drill can be changed by shifting the axis of the drill relative to the spindle axis.

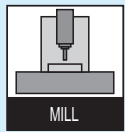

Taladro en U
U-Drill
U-Drill

Herramienta
Titulaire
Holder

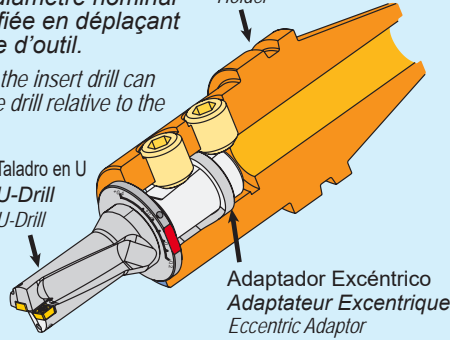

Adaptador Excéntrico
Adaptateur Excentrique
Eccentric Adaptor

Perno de ajuste radial.
(no incluido)

Broche de réglage radial. (non fourni)

Radial adjustment pin.
(not included)

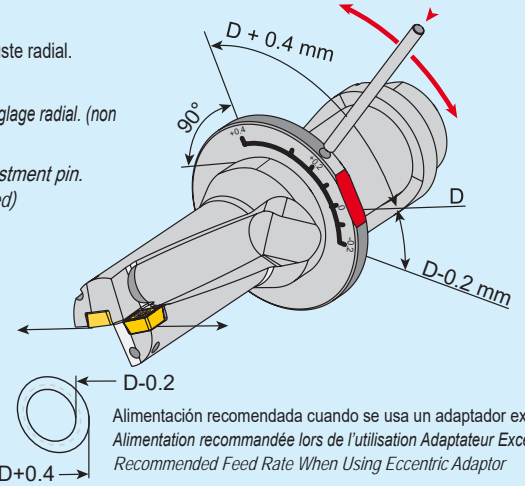

Alimentación recomendada cuando se usa un adaptador excéntrico
 Alimentation recommandée lors de l'utilisation Adaptateur Excentrique
 Recommended Feed Rate When Using Eccentric Adaptor

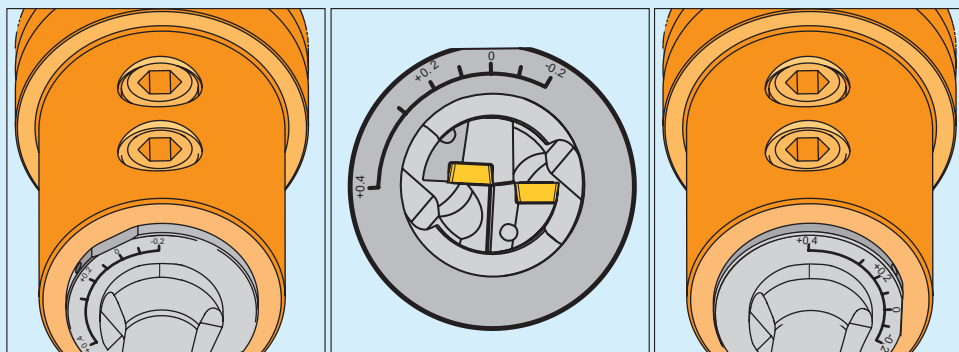

Diámetro del Agujero
24.8 mm
Diamètre du Trou
Hole Diameter

Diámetro del Agujero
25 mm
Diamètre du Trou
Hole Diameter

Diámetro del Agujero
25.4 mm
Diamètre du Trou
Hole Diameter

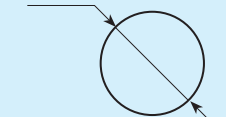
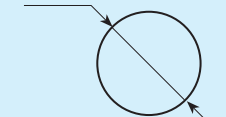
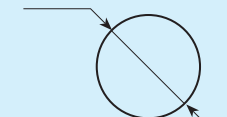

Diámetro del Taladro = 25 mm
Diamètre de Perçage = 25 mm
Drill Diameter = 25mm

Diámetro del Taladro = 25 mm
Diamètre de Perçage = 25 mm
Drill Diameter = 25mm

Diámetro del Taladro = 25 mm
Diamètre de Perçage = 25 mm
Drill Diameter = 25mm

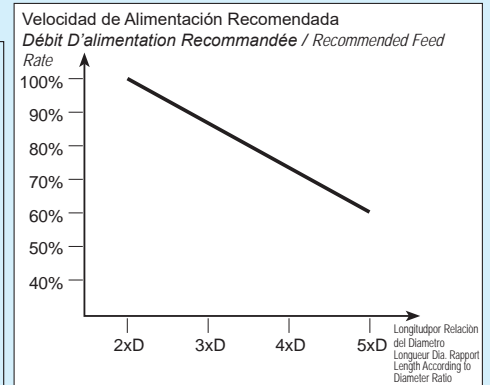

Las marcas de ajuste deben ubicarse perpendiculares al plano en la circunferencia de la brida U-DRILL. Para facilitar la rotación del adaptador, se puede insertar una varilla metálica o una llave de tornillo en un orificio en la brida del adaptador.

Les marques d'ajustement doivent être situées perpendiculairement au plat sur la circonférence de la brida en U DRILL. Pour faciliter la rotation de l'adaptateur, une tige métallique ou une clé à vis peuvent être insérées dans un trou sur la brida d'adaptation excentrique. Déverrouillage de la vis de l'adaptateur avant que l'adaptateur de réglage.

The adjustment markings should be located perpendicular to the flat on the circumference of the U-DRILL flange. To facilitate the rotation of the adaptor, a metal rod or a screw key may be inserted into a hole on the excentric adaptor flange. Unlock adapter screw before adjusting adaptor.

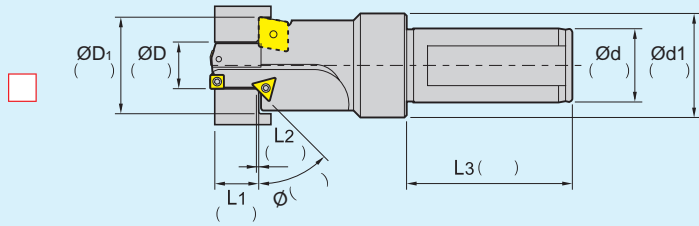

• Tipo de Refrigerante / Type de Liquide de Refroidissement / Coolant Type

- Kühlmittelzuführung über den Bund Kühlmittelbohrung durch den Schaft
 Fori di Lubrificazione Sulla Parte Immersa Fori di Lubrificazione Sullo Stelo
 Oil Hole On the Drill Part Oil hole On the Shank

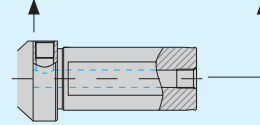

• Tipo de Agujero / Type de Trou / Hole Type

- Agujero Ciego A Través del Agujero
 Trou Borgne Trou Traversant
 Blind Hole Through Hole

• Tipos de Vástago / Types de Manche / Types of Shank

- Tipo Plano
 Type de Plat
 Flat Type

- Tipo Weldon
 Weldon Type
 Weldon Type

- Tipo Corte de Silbato
 Sifflet de Type Notch
 Whistle Notch Type

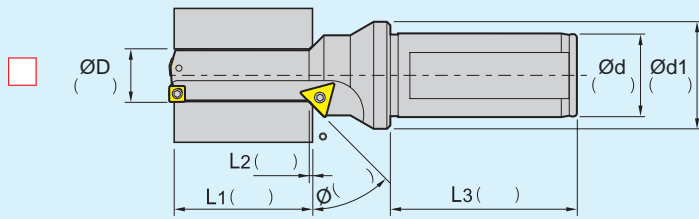

• Ubicación del Bloqueo Lateral / Emplacement du Côté de la Serrure / Location of Side Lock

- Paralelo al Inserto Periférico (estándar)
 Parallèle à Périphérique Plaquettes (Standard)
 Parallel to Peripheral Insert (Standard)

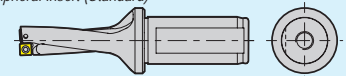

- Ángulo de 90° del Inserto Periférico
 90° Angle de Plaquette Périphérique
 90° Angle to Peripheral Insert

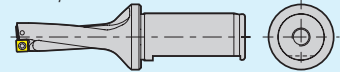

- Ángulo de 150° del Inserto Periférico.
 150° Angle de Plaquette Périphérique
 150° Angle to Peripheral Insert



- Ángulo de 180° del Inserto Periférico
 180° Angle de Plaquette Périphérique
 180° Angle to Peripheral Insert

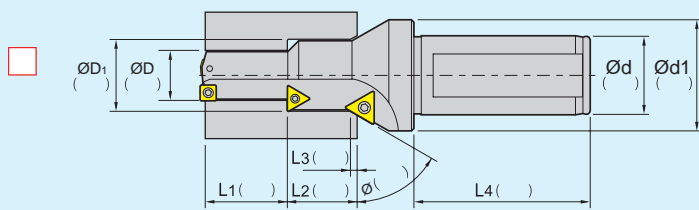
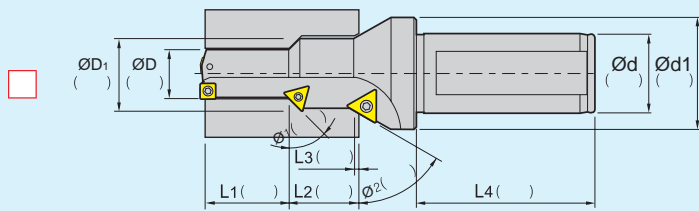
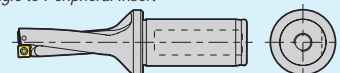

• Nota / Note / Note :

- Actualmente Usando la Herramienta / À l'heure Actuelle en Utilisant l'outil
 • Currently Using Tool
- Condición de Corte Actual / Condition de Coupe Actuelle
 • Current Cutting Condition
- RPM o vc (m / min) / - RPM ou vc (m / min)
 - RPM or vc (m/min)
- Vf(mm/min) or Fn(mm/rev)
 - Vf (mm / min) ou Fn (mm / rev) / Vf(mm/min) or Fn(mm/rev)
- Profundidad de Corte (mm) / Profondeur de Coupe (mm)
 - Depth of Cut(mm)
- Estándar Medición de la Vida Útil de la Herramienta / Norme de Mesure Outil Vie
 • Standard Measured Tool Life
- Actualmente Utilizando la Máquina / À l'heure Actuelle en Utilisant la Machine
 • Currently Using Machine
- Centro de Mecanizado / Centre D'usinage
 - Machining Center
- Torno General / Tour Générale
 - General Lathe
- Torno CNC / Tour CNC
 - CNC Lathe

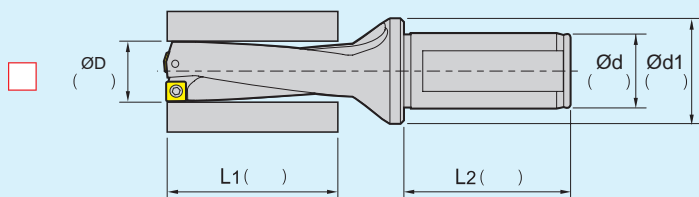



konusulan
the spoken kalite...
quality...

ECONOMIC CUTTING TOOLS

HERRAMIENTAS DE CORTE ECONÓMICAS
OUTILS DE COUPE ÉCONOMIQUE
ECONOMIC CUTTING TOOLS





AKKO **A** **EK** **R** - **D2.25** x **20**

X **C** **.** **.** **10** **T3** **04**

2 Estilo de Corte / Type D'outil / Cutting Style

EK : Corte Económico / Découpage Économique
 Economic Cutter

3 Dirección de Corte / Direction de Coupe / Cutting Direction

11 Grosor / Épaisseur / Thickness

01	s = 1.59
T1	s = 1.98
O2	s = 2.38
T2	s = 2.78
O3	s = 3.18
T3	s = 3.97
O4	s = 4.76
O5	s = 5.56
O6	s = 6.35
O7	s = 7.94
O9	s = 9.52

4 Profundidad de Perforación / Profondeur Perçage / Drilling Depth

5 Diámetro de Herramienta / Diamètre de l'outil / Tool Diameter

6 Plattenform / Forma Inserto / Insert Shape

8 Tolerancia / Tolérance / Tolerance

	IC	M	S
A	± 0.025	± 0.005	± 0.025
C	± 0.025	± 0.013	± 0.025
E	± 0.025	± 0.025	± 0.025
F	± 0.013	± 0.005	± 0.025
G	± 0.025	± 0.025	± 0.130
H	± 0.013	± 0.013	± 0.025
J	± 0.05-0.15	± 0.005	± 0.025
K	± 0.05-0.15	± 0.013	± 0.025
L	± 0.05-0.15	± 0.025	± 0.025
M	± 0.05-0.15	± 0.08-0.20	± 0.130
N	± 0.05-0.15	± 0.08-0.20	± 0.025
U	± 0.08-0.25	± 0.13-0.38	± 0.130

IC: Circulo Inscrito / Cercle Inscrit / Inscribed Circle
 M: Remítase a la Figura / Reportez-vous à la Figure / Refer to Figure
 S: Grosor / Épaisseur / Thickness

9 Tipo de Inserto / Type de Plaquette / Insert Type

7 Inserto de ángulo libre Frietwinkel / Plaquettes Clearance Ange Freiwinkel / Clearance angle of the insert

10 Longitud del Filo / Longueur de Coupe / Cutting Edge Length

12 Radio de Esquina / Rayon de l'angle / Corner Radius

01	RE=0.1	12	RE=1.2
02	RE=0.2	16	RE=1.6
04	RE=0.4	24	RE=2.4
08	RE=0.8		

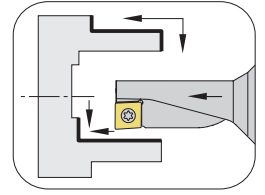
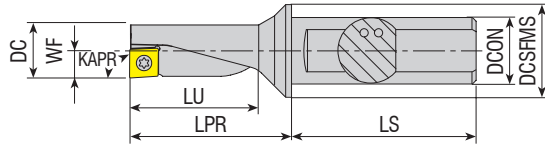

Código del Inserto Le Code de Commande Ordering Code	Stock Stock Stock		Dimension (mm) Dimension (mm) Dimension (mm)							Inserto Plaque Insert	Recambios / Pièces de Rechange / Spare Parts	
	R	L	DC	DCON	DCSFMS	LU	LPR	LS	WF	Tornillo Vis Screw	Llave Torx Clé Torx Torx Wrench	
AEKR/L-D2.25X8 XC.. 040104	●	●	8	10	12	18	22	38	4	XC.. 040104	3006-M1.8x4	80-T06
AEKR/L-D2.25X10 XC.. 050204	●	●	10	12	16	22.5	27.5	42	5	XC.. 050204	3006-M2x4	80-T06
AEKR/L-D2.25X12 XC.. 060204	●	●	12	16	20	27	33	45	6	XC.. 060204	3007-M2.2x5	80-T07
AEKR/L-D2.25X14 XC.. 070304	●	●	14	16	20	31.5	38	45	7	XC.. 070304	3008-M2.5x6	80-T08
AEKR/L-D2.25X16 XC.. 080304	●	●	16	20	25	36	44	50	8	XC.. 080304	3008-M3x6	80-T08
AEKR/L-D2.25X18 XC.. 09T304	●	●	18	25	32	40.5	53.5	56	9	XC.. 09T304	4015-M3.5x9	80-T15
AEKR/L-D2.25X20 XC.. 10T304	●	●	20	25	32	45	55	56	10	XC.. 10T304	4020-M4.5x10	80-T15
AEKR/L-D2.25X25 XC.. 130404	●	●	25	32	40	56.5	69	60	12.5	XC.. 130404	4020-M4.5x10	80-T20
AEKR/L-D2.25X32 XC.. 170504	●	●	32	32	50	72	88	60	16	XC.. 170504	4020-M4.5x12	80-T20

R: Derecha / Droite / Right L: Izquierda / Gauche / Left
 ● En Existencia / En stock / In Stock ○ Artículo sin Existencia / Indisponible en Stock / Non Stock Item
 Compatible con el Inserto CRTZT-ISCR-TGTC-KRLY. / Compatible avec CRTZT-ISCR-TGTC-KRLY Plaquettes.
 Compatible with CRTZT-ISCR-TGTC-KRLY Insert.

Ejemplo de Pedido / Exemple de Commande / Ordering Example
 1 Piezas / pcs. / pcs. AEKR-D2.25X8 XC.. 040104

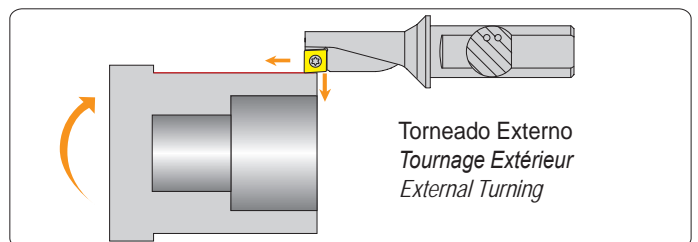
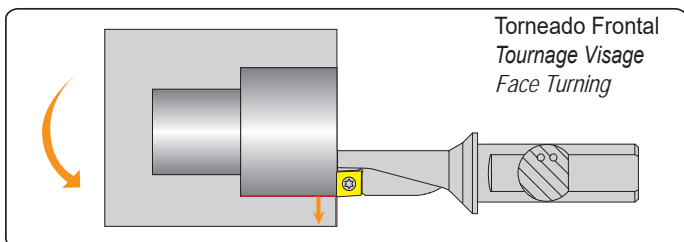
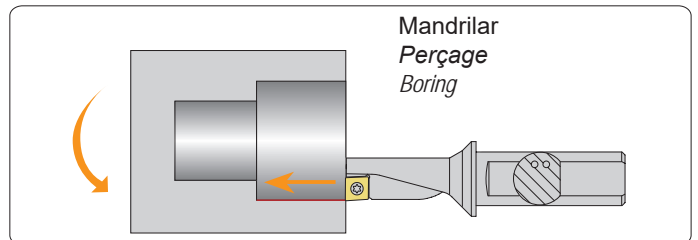
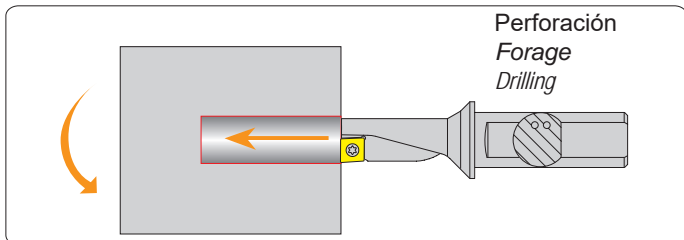
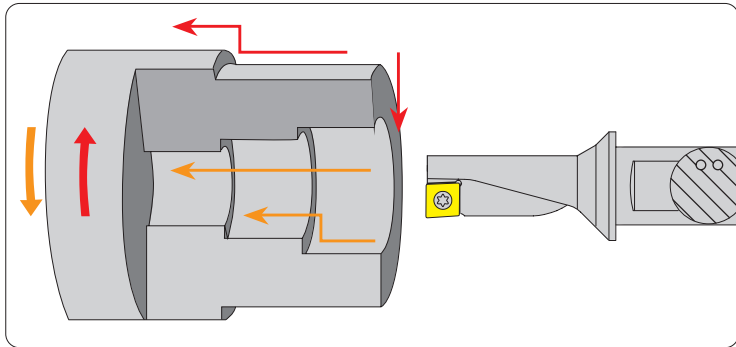

BORING HEADS

CABEZAS DE MANDRINAR AJUSTABLE
TÊTE À ALÉSER RÉGLABLE
ADJUSTABLE BORING HEADS

konusulan
the spoken kalite...
quality...



AKKO **A** **BH** **R** - **D18x22**

1 2 3 4

W16 - **L90** - **CC06**

5 6 7

2 Estilo de Corte / Type D'outil / Cutting Style

BH : Mandriladores / Tête de Perçage
Boring Head

3 Solicitud / Application / Application Type

R : Mandrilador Aspero / Forage Rugueux
Rough Boring
F : Mandrilador de Precisió / Forage Fine
Fine Boring

5 Forma del Montaje / Type de Montage / Assembly Form

W : Weldon

4 Rango de Perforaci3n / Plage de Perçage / Size Range

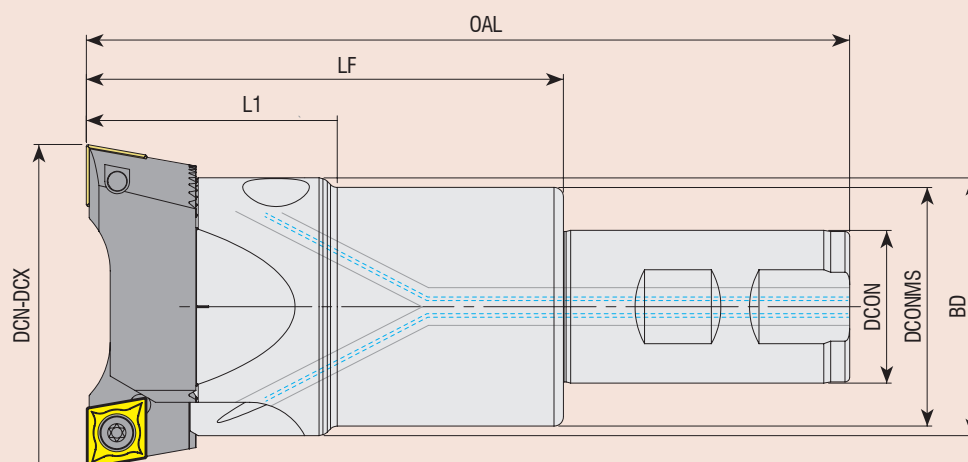

6 Longitud de la Herramienta / Longueur D'outil / Tool Length

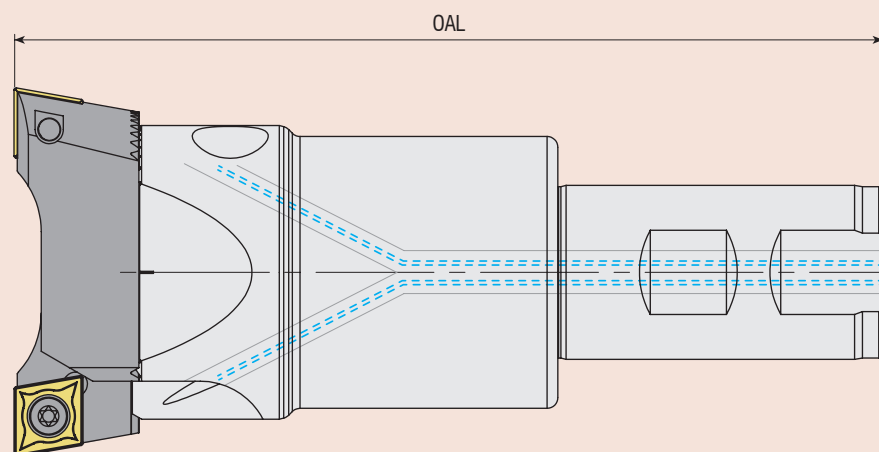

7 Inserto / Plaque / Insert

CC06 : CC.. 0602..
 CC09 : CC.. 09T3..
 CC12 : CC.. 1204..

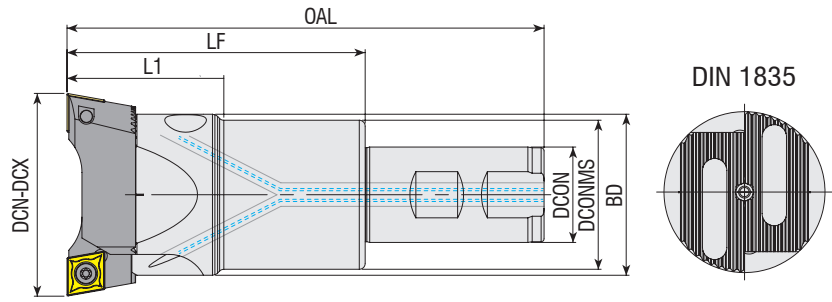

Código del Inserto Le Code de Commande Ordering Code	Stock Stock Stock	Rango de Perforación Plage de Perçage Size Range DCN-DCX	Dimension (mm) Dimension (mm) Dimension (mm)					Cartucho Cartouche Cartridge	Codigo de Cuerpo Cabeza de Mandrilar Code du Manche Boring Head Body Code	
			DCON	DCONMS	BD	OAL	LF			L1
ABHR-D18x22-W16-L90-CC06	●	18-22	16	-	-	90	42	-	AK.. 18-22	ABHRS-D16x42-W16-L90
ABHR-D18x22-W16-L150-CC06	●	18-22	16	-	-	150	102	-		ABHRS-D16x102-W16-L150
ABHR-D18x22-W16-L200-CC06	●	18-22	16	-	-	200	152	-		ABHRS-D16x152-W16-L200
ABHR-D22x28-W20-L100-CC06	●	22-28	20	-	-	100	50	-	AK.. 22-28	ABHRS-D20x50-W20-L100
ABHR-D22x28-W20-L150-CC06	●	22-28	20	-	-	150	100	-		ABHRS-D20x100-W20-L150
ABHR-D22x28-W20-L200-CC06	●	22-28	20	-	-	200	150	-		ABHRS-D20x150-W20-L200
ABHR-D28x38-W20-L110-CC06	●	28-38	20	25	-	110	60	-	AK.. 28-38	ABHRS-D25x60-W20-L110
ABHR-D28x38-W20-L160-CC06	●	28-38	20	25	-	160	110	-		ABHRS-D25x110-W20-L160
ABHR-D28x38-W20-L230-CC06	●	28-38	20	25	-	230	180	-		ABHRS-D25x180-W20-L230
ABHR-D36x50-W25-L120-CC06	●	36-50	25	32	-	120	64	-	AK.. 36-50	ABHRS-D32x64-W25-L120
ABHR-D36x50-W25-L170-CC06	●	36-50	25	32	-	170	114	-		ABHRS-D32x114-W25-L170
ABHR-D36x50-W25-L250-CC06	●	36-50	25	32	-	250	194	-		ABHRS-D32x194-W25-L250
ABHR-D36x50-W25-L120-CC09	●	36-50	25	32	-	120	64	-	AK.. 36-50-09	ABHRS-D32x64-W25-L120
ABHR-D36x50-W25-L170-CC09	●	36-50	25	32	-	170	114	-		ABHRS-D32x114-W25-L170
ABHR-D36x50-W25-L250-CC09	●	36-50	25	32	-	250	194	-		ABHRS-D32x194-W25-L250
ABHR-D50x68-W32-L140-CC09	●	50-68	32	40	-	140	80	-	AK.. 50-68	ABHRS-D40x80-W32-L140
ABHR-D50x68-W32-L200-CC09	●	50-68	32	40	-	200	140	-		ABHRS-D40x140-W32-L200
ABHR-D50x68-W32-L280-CC09	●	50-68	32	40	-	280	220	-		ABHRS-D40x220-W32-L280
ABHR-D50x68-W32-L140-CC12	●	50-68	32	40	-	140	80	-	AK.. 50-68-12	ABHRS-D40x80-W32-L140
ABHR-D50x68-W32-L200-CC12	●	50-68	32	40	-	200	140	-		ABHRS-D40x140-W32-L200
ABHR-D50x68-W32-L280-CC12	●	50-68	32	40	-	280	220	-		ABHRS-D40x220-W32-L280
ABHR-D68x90-W32-L160-CC12	●	68-90	32	50	54	160	100	50	AK.. 68-90	ABHRS-D50x100-W32-L160
ABHR-D68x90-W32-L210-CC12	●	68-90	32	50	54	210	150	50		ABHRS-D50x150-W32-L210
ABHR-D68x90-W32-L280-CC12	●	68-90	32	50	54	280	220	50		ABHRS-D50x220-W32-L280
ABHR-D90x120-W32-L140-CC12	●	90-120	32	63	72	140	80	63	AK.. 90-120	ABHRS-D63x80-W32-L140
ABHR-D90x120-W40-L200-CC12	●	90-120	40	63	72	200	130	63		ABHRS-D63x130-W40-L200
ABHR-D90x120-W40-L300-CC12	●	90-120	40	63	72	300	230	63		ABHRS-D63x230-W40-L300
ABHR-D120x160-W40-L210-CC12	●	120-160	40	80	95	210	140	75	AK.. 120-160	ABHRS-D80x140-W40-L210
ABHR-D120x160-W40-L300-CC12	●	120-160	40	80	95	300	230	75		ABHRS-D80x230-W40-L300
ABHR-D160x200-W40-L210-B-CC12	●	160-200	40	80	95	210	140	75	AK.. 160-800	ABHRS-D80x140-W40-L210
ABHR-D160x200-W40-L300-B-CC12	●	160-200	40	80	95	300	230	75		ABHRS-D80x230-W40-L300

R: Derecha / Droite / Right L: Izquierda / Gauche / Left

● En Existencia / En stock / In Stock ○ Artículo sin Existencia / Indisponible en Stock / Non Stock Item

Cuando se solicite, el cuerpo y el cartucho se enviarán según lo establecido. / Lors de la commande, le corps et la cartouche seront envoyés en série.

When ordered, body and cartridge will be sent as a set.

Ejemplo de Pedido / Exemple de Commande / Ordering Example

1 Piezas / pcs. / pcs. ABHR-D18x22-W16-L90-CC06

CUERPO DE CABEZALES DE PERFORACIÓN EN BRUTO AJUSTABLE
CHEFS ASEPTISÉE RÉGLABLE BRUTE CORPS
ADJUSTABLE ROUGH BORING HEADS BODY

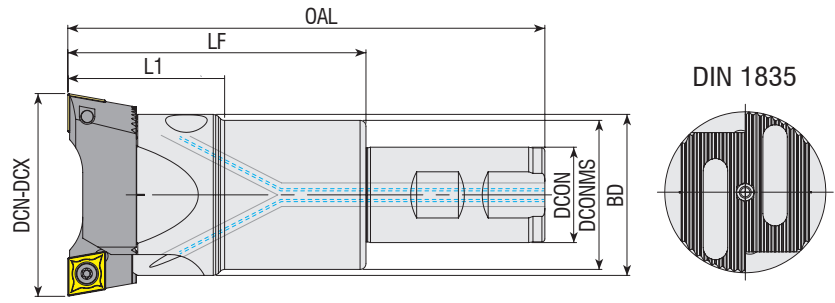

Código del Inserto Le Code de Commande Ordering Code	Stock Stock Stock	Rango de Perforación Plage de Perçage Size Range DCN-DCX	Dimension (mm) Dimension (mm) Dimension (mm)					Recambios / Pièces de Rechange / Spare Parts					
			DCON	DCONMS	BD	OAL	LF	L1	Tornillo de Fijación Vis de Fixation Mounting Screw	Tornillo de Montaje Llave Allen Vis de Montage Cle Allen Mounting Screw Wrench	Abrazadera Bride Wedge	Ajustable Vis Ajustable Adjust Screw	Llaves Allen Clés Allen Allen Wrench
ABHRS-D16x42-W16-L90	●	18-22	16	-	-	90	42	-					
ABHRS-D16x102-W16-L150	●	18-22	16	-	-	150	102	-	2525-M3x14	AAL-02-2.5	ABKS-D16	2715-M3x4	
ABHRS-D16x152-W16-L200	●	18-22	16	-	-	200	152	-					
ABHRS-D20x50-W20-L100	●	22-28	20	-	-	100	50	-					
ABHRS-D20x100-W20-L150	●	22-28	20	-	-	150	100	-	2503-M4x15	AAL-03-3	ABKS-D20	2715-M3x5	AAL-09-1.5
ABHRS-D20x150-W20-L200	●	22-28	20	-	-	200	150	-					
ABHRS-D25x60-W20-L110	●	28-38	20	25	-	110	60	-					
ABHRS-D25x110-W20-L160	●	28-38	20	25	-	160	110	-	2503-M4x20	AAL-03-3	ABKS-D25	2715-M3x8	
ABHRS-D25x180-W20-L230	●	28-38	20	25	-	230	180	-					
ABHRS-D32X64-W25-L120	●	36-50	25	32	-	120	64	-					
ABHRS-D32X114-W25-L170	●	36-50	25	32	-	170	114	-	2504-M5x25	AAL-05-4	ABKS-D32	2702-M4x12	AAL-01-2
ABHRS-D32X194-W25-L250	●	36-50	25	32	-	250	194	-					
ABHRS-D40x80-W32-L140	●	50-68	32	40	-	140	80	-					
ABHRS-D40x140-W32-L200	●	50-68	32	40	-	200	140	-	2505-M6x30	AAL-07-5	ABKS-D40	2725-M5x16	
ABHRS-D40x220-W32-L280	●	50-68	32	40	-	280	220	-					AAL-02-2.5
ABHRS-D50x100-W32-L160	●	68-90	32	50	54	160	100	50					
ABHRS-D50x150-W32-L210	●	68-90	32	50	54	210	150	50	2506-M8x35	AAL-08-6	ABKS-D50	2725-M5x12	
ABHRS-D50x220-W32-L280	●	68-90	32	50	54	280	220	50					
ABHRS-D63x80-W32-L140	●	90-120	32	63	72	140	80	63					
ABHRS-D63x130-W40-L200	●	90-120	40	63	72	200	130	63	2508-M10x40	AAL-11-8	ABKS-D63	2703-M6x16	AAL-03-3
ABHRS-D63x230-W40-L300	●	90-120	40	63	72	300	230	63					
ABHRS-D80x140-W40-L210	●	120-160	40	80	95	210	140	75	2510-M12x40	AAL-12-10	ABKS-D80	2704-M8x25	AAL-05-4
ABHRS-D80x230-W40-L300	●	120-160	40	80	95	300	230	75					
ABHRS-D80x140-W40-L210	●	160-200	40	80	95	210	140	75					
ABHRS-D80x230-W40-L300	●	160-200	40	80	95	300	230	75					

R: Derecha / Droite / Right L: Izquierda / Gauche / Left

● En Existencia / En stock / In Stock ○ Artículo sin Existencia / Indisponible en Stock / Non Stock Item

Ejemplo de Pedido / Exemple de Commande / Ordering Example

1 Piezas / pcs. / pcs. ABHRS-D16x42-W16-L90

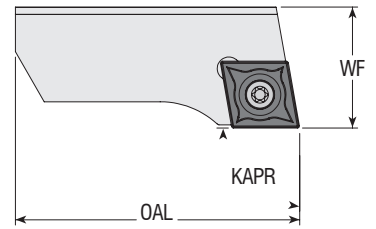

Código del Inserto Le Code de Commande Ordering Code	Stock Stock Stock	Dimension (mm) Dimension (mm) Dimension (mm)			Inserto Plaquette Insert	Recambios / Pièces de Rechange / Spare Parts		
		Rango de Perforación Plage de Perçage Size Range	WF	OAL		Tornillo Vis Screw	Llave Torx Clé Torx Torx Wrench	
AKSR 18-22	●	18-22	9	15				
AKSR 22-28	●	22-28	10	19				
AKSR 28-38	●	28-38	13	23				
AKSR 36-50	●	36-50	16	32	CC.T 09T3..	4015-M3.5x8	80-T15	
AKSR 36-50-09	●	36-50	16	32				
AKSR 50-68	●	50-68	20	40	CC.T 1204..	1020-M5x11	80-T20	
AKSR 50-68-12	●	50-68	20	40				
AKSR 68-90	●	68-90	23	54				
AKSR 90-120	●	90-120	28	70				
AKSR 120-160	●	120-160	32	95				
AKSR 160-800	●	160-800	32	120				

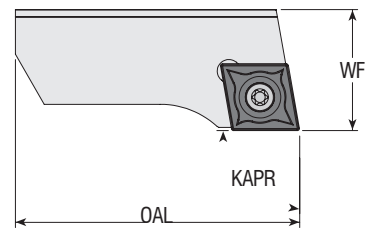

Código del Inserto Le Code de Commande Ordering Code	Stock Stock Stock	Dimension (mm) Dimension (mm) Dimension (mm)			Inserto Plaquette Insert	Recambios / Pièces de Rechange / Spare Parts		
		Rango de Perforación Plage de Perçage Size Range	WF	OAL		Tornillo Vis Screw	Llave Torx Clé Torx Torx Wrench	
AKCR 28-38	●	28-38	12.8	23				
AKCR 36-50	●	36-50	15.8	32				
AKCR 36-50-09	●	36-50	15.8	32				
AKCR 50-68	●	50-68	19.7	40	CC.T 09T3..	4015-M3.5x8	80-T15	
AKCR 50-68-12	●	50-68	19.7	40				
AKCR 68-90	●	68-90	22.7	54	CC.T 1204..	1020-M5x11	80-T20	
AKCR 90-120	●	90-120	27.7	70				
AKCR 120-160	●	120-160	31.7	95				
AKCR 160-800	●	160-800	31.7	120				

R: Derecha / Droite / Right L: Izquierda / Gauche / Left
 ● En Existencia / En stock / In Stock ○ Artículo sin Existencia / Indisponible en Stock / Non Stock Item
 Compatible con el Inserto ISO. / Compatible avec ISO Plaquettes. / Compatible with ISO Insert.

Ejemplo de Pedido / Exemple de Commande / Ordering Example
 1 Piezas / pcs. / pcs. AKSR 18-22

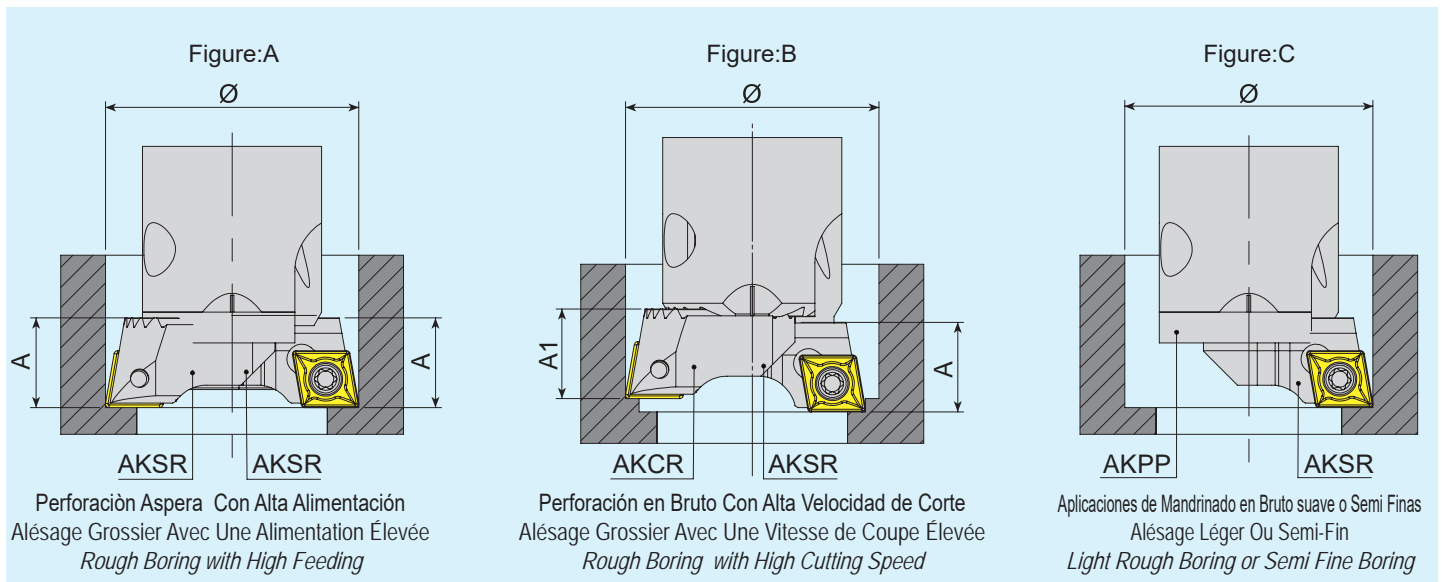

1. El ajuste radial de los filos de corte debe realizarse con un equipo de preajuste de herramientas.
2. Las barras de MANDRINAR provistas para los dos bolsillos de los insertos son para operaciones de desbaste que requieren la remoción de virutas pesadas
 Las barras de mandrinar de doble inserción incluyen:
 - Dos cartuchos AKSR en el mismo plano con dos filos de corte establecidos a una distancia radial idéntica para operaciones de desbaste de alta velocidad de avance (fig. A)
 - Un cartucho AKCR y un cartucho AKSR que no están en el mismo plano para operaciones de desbaste de alta deuda. (fig. B)
 - i. Con la operación de Mandrilado en bruto, esto permite duplicar el ancho de corte, utilizando solo una velocidad de alimentación única. ($f = f1$)
 - ii. Con la operación de Mandrilado de acabado, el ancho de corte se divide para que se pueda omitir parte del mecanizado intermedio.
3. Las barras de MANDRINAR equipadas con un solo cartucho son para operaciones de desbaste y acabado que implican la extracción normal de virutas. Siempre se debe utilizar la placa de protección de superficie dentada AKPP (fig. C)

1. Le réglage radial des arêtes de coupe doit être effectué avec un équipement de mesure d'outils.
2. L'outil d'alésage équipé d'inserts doubles est destiné aux opérations d'alésage grossier impliquant l'enlèvement de copeaux lourds.
 Double insère des bars d'alésage:
 - Deux cartouches AKSR sur le même plan avec deux arêtes de coupe réglées à une distance radiale identique pour les opérations d'ébauche à vitesse d'avance élevée (fig. A).
 - Une cartouche AKCR et une cartouche AKSR ne sont pas sur le même plan pour les opérations d'ébauche à haut débit. (fig. B)
- je. Dans les opérations de forage grossier, la quantité de passes à effectuer est divisée par deux, ce qui entraîne une coupe en douceur, mais dans ce cas, la vitesse d'avance par tour doit être calculée comme un dent. ($F = f1$)
- ii. Avec l'opération d'alésage de finition, la largeur de coupe est divisée de sorte qu'une partie de l'usinage intermédiaire peut être omise.
3. Les bars d'alésage équipées d'une seule cartouche sont destinées aux opérations d'ébauche et de finition impliquant un enlèvement normal des copeaux. La plaque de protection de surface dentelée AKPP doit toujours être utilisée (fig.C)

1. The radial adjustment of the cutting edges should be done with tool measuring equipment.
2. Double inserts fitted boring tool is for rough boring operations involving heavy chip removal.
 Double inserts boring bars:
 - Two AKSR cartridges on the same plane with two cutting edges set at identical radial distance for high feed rate roughing operations. (fig. A)
 - An AKCR cartridge and an AKSR cartridge not on the same plane for high-debth roughing operations. (fig. B)
- i. In rough boring operations, the amount of passes to be taken is divided by two, which results in a smooth cut, but in this case, the feed rate per revolution should be calculated as one tooth. ($F = f1$)
- ii. With the finish boring operation, the cutting width is divided so that some of the intermediate machining can be omitted.
3. Boring bars fitted with a single cartridge are for roughing and finishing operations involving normal chip removal. The serrated surface protection plate AKPP should always be used (fig. C)



konusulan
the spoken kalite...
quality...

HERRAMIENTAS DE FRESADO
OUTILS MILLING
MILLING TOOLS



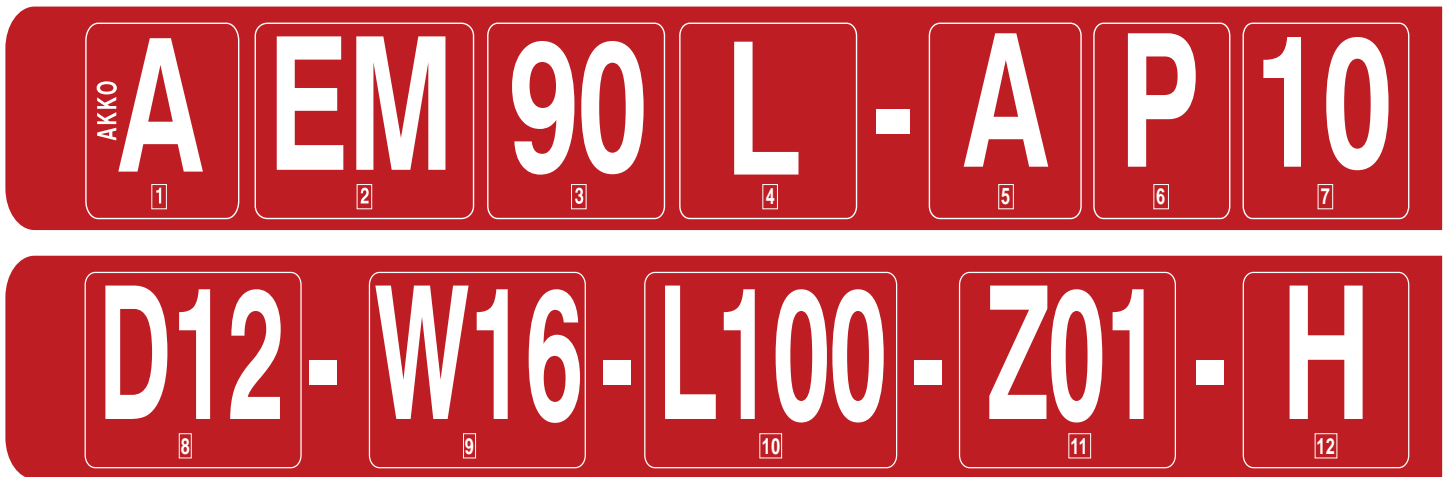

2 Estilo de Corte / Type D'outil / Cutting Style

FM: Herramientas de Fresado / Outils de Surfaçage / Face Milling Tools
 EM: Herramientas de Fresado de Cara Final / Outils de Surfaçage en Bout / End Face Milling Tools
 CM: Herramientas de Fresado de Chaflán / Outils en Bout a Chanfreiner / Chamfering End Milling Tools
 HM: Herramientas de Fresado Helicoidal / Outils en Bout Helique / Helix End Milling Tools
 TSM: Herramientas de Fresado de Ranura en T / Outils de Fraisage en T / T Slot Milling Tools
 HFM: Herramientas de Fresado de Alto Avance / Outils de Fraisage à Haute Alimentation / High Feed Milling Tools
 PMR: Herramientas de Fresado de Punta Esférica / Fraises à Bouts Sphériques / Ball Nose End Milling Tools
 SDM: Fresado Ranura de Disco / Fente du Disque de Fraisage / Slot Disc Milling
 CBM: Herramienta de Fresado Avellanado Para Tornillos Cilíndricos de Cabeza Allen / Fraise à Chanfreiner Pour Vis à Tête Cylindrique Allen
 Countersink Milling Tool for Cylindrical Allen Head Screws

3 Cabeza Allen / Angle de Plomb / Lead Angle

90° - 75° - 60° - 45°
 20° - 15° - 11° - 5° - 0°

4 Cabeza Allen / Angle de Plomb / Lead Angle

L: Izquierda / Gauche / Left
 C: Abrazadera de Cuñas / Mode de Fixation / Wedge Clamp
 S: Cuñas / Assise / Shim
 CL: Ángulo de Avance / Gauche Way Avec Pince
 Left Way with Clamp
 CS: Abrazadera Con Cuñas / Pince Avec Assise
 Clamp with Shim
 CSL: Abrazadera Lado Izquierdo Con Cuñas / Bride Gauche Avec Assise
 Left Way Clamp with Shim

5 Forma de Inserto / Forme de la Plaquette / Insert Shape

C	D	E	K
L	R	S	T
V	W	A	B
H	M	O	P

6 Inserto de ángulo libre Frietwinkel
 Plaquettes Clearance Ange Freiwinkel / Clearance Angel of The Insert

A	B	C
D	E	F
G	N	P

7 Longitud del Filo
 Longueur de Coupe
 Cutting Edge Length

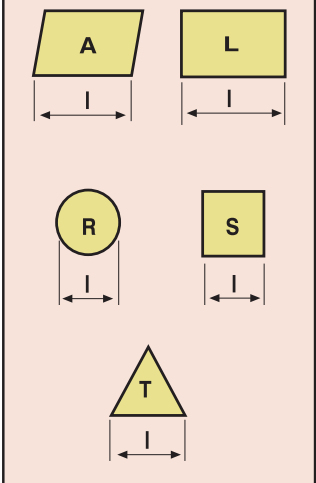

8 Diámetro de Herramienta / Diamètre de l'outil / Tool Diameter

9 Forma de Ensamblaje y Diámetro / Forme D'assemblage et Diamètre / Assembly Form and Diameter

A, B, C, D: Forma de Ensamblaje y Diámetro / Forme D'assemblage et Diamètre / Assembly Form and Diameter
 C: Mango Cilíndrico / Jarret Cylindrique / Cylindrical Shank
 W: Weldon

10 Longitud Total / Longueur Totale / Overall Length

11 Número de Dientes Efectivos / Nombre de Dents Efficace / Number of Effective Tooth

12 Con Agujero de Refrigerante / Avec Trou D'arrosage / With Coolant Hole

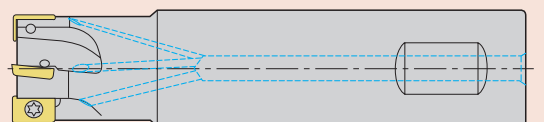

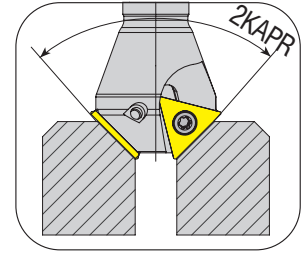
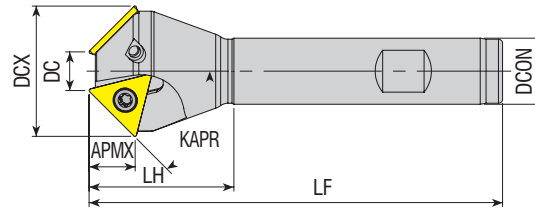
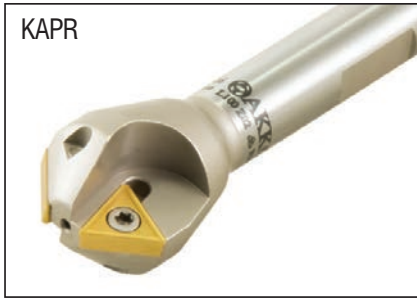

Código del Inserto Le Code de Commande Ordering Code	Stock Stock Stock	Dimension (mm) Dimension (mm) Dimension (mm)								Inserto Plaquette Insert	Recambios / Pièces de Rechange / Spare Parts				
		KAPR	DC	DCX	DCON	LF	LH	ZEFP	APMX		Tornillo Vis Screw	Llave Torx Clé Torx Torx Wrench			
ACM10-TC16-D17X22-W16-L90-Z01	●	10°	17	22	16	90	30	1	15.2	TC.T 16T304					
ACM15-TC16-D17X24-W16-L90-Z01	●	15°	17	24	16	90	30	1	14.9						
ACM15-TC16-D22X29-W16-L100-Z01	●	15°	22	29	16	100	30	1	14.9						
ACM15-TC16-D30X37-W20-L100-Z02	●	15°	30	37	20	100	35	2	14.9						
ACM15-TC16-D35X42-W20-L100-Z03	●	15°	35	42	20	100	38	3	14.9						
ACM15-TC16-D52X59-W25-L110-Z03	●	15°	52	59	25	110	40	3	14.9						
ACM17.5-TC16-D17X25-W16-L90-Z01	●	17.5°	17	25	16	90	30	1	14.7						
ACM18.5-TC16-D21.3X30-W20-L100-Z02	●	18.5°	21.3	30	20	100	30	2	13.5				TC.T 16T308		
ACM20-TC16-D12X22-W16-L100-Z01	●	20°	12	22	16	100	30	1	14.4				TC.T 16T304	4015-M3.5x9	80-T15
ACM20-TC16-D17X27-W16-L100-Z01	●	20°	17	27	16	100	30	1	14.4						
ACM20-TC16-D23X33-W20-L100-Z02	●	20°	23	33	20	100	30	2	14.4						
ACM20-TC16-D28X38-W20-L100-Z02	●	20°	28	38	20	100	35	2	14.4						
ACM20-TC16-D35X45-W20-L100-Z03	●	20°	35	45	20	100	40	3	14.4						
ACM20-TC16-D39X49-W20-L100-Z03	●	20°	39	49	20	100	40	3	14.4						
ACM20-TC16-D45X55-W25-L110-Z03	●	20°	45	55	25	110	40	3	14.4						
ACM20-TC16-D51X61-W25-L110-Z03	●	20°	51	61	25	110	40	3	14.4						
ACM22.5-TC16-D17X28-W16-L100-Z01	●	22.5°	17	28	16	100	30	1	14.2						
ACM25-TC16-D17X29-W16-L100-Z01	●	25°	17	29	16	100	30	1	13.9						
ACM30-TC16-D6X20-W16-L100-Z01	●	30°	6	20	16	100	30	1	13.3	TC.T 090204	3007-M2.2x5	80-T07			
ACM30-TC16-D15X30-W16-L100-Z01	●	30°	15	30	16	100	30	1	13.3						
ACM30-TC16-D17.5X32.5-W20-L100-Z02	●	30°	17.5	32.5	20	100	30	2	13.3						
ACM30-TC16-D20X35-W16-L100-Z02	●	30°	20	35	16	100	35	2	13.3						
ACM30-TC16-D30X45-W20-L100-Z02	●	30°	30	45	20	100	40	2	13.3						
ACM30-TC16-D35X50-W20-L100-Z03	●	30°	35	50	20	100	40	3	13.3						
ACM30-TC16-D45X60-W25-L110-Z03	●	30°	45	60	25	110	40	3	13.3						
ACM45-TC09-D7X18-W16-L100-Z02	●	45°	7	18	16	100	25	2	5.9						
ACM45-TC11-D11X24-W16-L100-Z02	●	45°	11	24	16	100	25	2	6.9				TC.T 110204	3008-M2.5x6	80-T08
ACM45-TC16-D5X26-W16-L100-Z01	●	45°	5	26	16	100	30	1	10.8				TC.T 16T304	4015-M3.5x9	80-T15
ACM45-TC16-D10X31-W16-L100-Z02	●	45°	10	31	16	100	35	2	10.8						
ACM45-TC16-D10X31-W20-L100-Z02	●	45°	10	31	20	100	35	2	10.8						
ACM45-TC16-D18X39-W16-L100-Z02	●	45°	18	39	16	100	40	2	10.8						
ACM45-TC16-D18X39-W20-L100-Z02	●	45°	18	39	20	100	40	2	10.8						
ACM45-TC16-D20X41-W20-L100-Z02	●	45°	20	41	20	100	40	2	10.8						
ACM45-TC16-D30X51-W20-L100-Z02	●	45°	30	51	20	100	40	2	10.8						
ACM55-TC16-D16X40-W20-L100-Z03	●	55°	16	40	20	100	40	3	8.7						
ACM62-TC16-D14X40-W20-L100-Z03	●	62°	14	40	20	100	40	3	7.1						
ACM72-TC16-D14X42-W20-L100-Z03	●	72°	14	42	20	100	40	3	4.6						

R: Derecha / Droite / Right L: Izquierda / Gauche / Left

● En Existencia / En stock / In Stock ○ Artículo sin Existencia / Indisponible en Stock / Non Stock Item
 Compatible con el Inserto ISO. / Compatible avec ISO Plaquettes. / Compatible with ISO Insert.

Ejemplo de Pedido / Exemple de Commande / Ordering Example

1 Piezas / pcs. / pcs. ACM10-TC16-D17X22-W16-L90-Z01

Cálculo de Corte : S 369 / Calcul de Coupe : P 369 / Cutting Calculation : 369

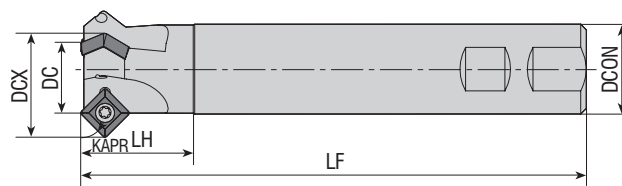

Código del Inserto Le Code de Commande Ordering Code	Stock Stock Stock	Dimension (mm) Dimension (mm) Dimension (mm)								Inserto Plaquette Insert	Recambios / Pièces de Rechange / Spare Parts	
		KAPR	DC	DCX	DCON	LF	LH	ZEFP	a		Tornillo Vis Screw	Llave Torx Clé Torx Torx Wrench
ACM45-SP1104-D12x26-W20-L150-Z01	●	45°	12	26	20	150	30	1	-	SPGT 110408	4015-M4x9	80-T15
ACM45-SP1104-D25x39-W25-L150-Z02	●	45°	25	39	25	150	35	2	-			
ACM45-SP1104-D32x46-W32-L150-Z03	●	45°	32	46	32	150	40	3	-			

Compatible con el Inserto ZCC. / Compatible avec ZCC Plaquettes. / Compatible with ZCC Insert.

➤ HERRAMIENTAS DE FRESADO BISELADO EN HELICE
 FRAISES À CHANFREINER HELIQUE
 HELIX CHAMFER MILLING TOOLS

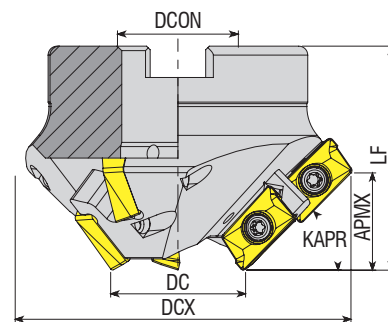

Código del Inserto Le Code de Commande Ordering Code	Stock Stock Stock	Dimension (mm) Dimension (mm) Dimension (mm)								Inserto Plaquette Insert	Recambios / Pièces de Rechange / Spare Parts	
		ZEFP		KAPR	DC	DCX	DCON	APMX	LF		Tornillo Vis Screw	Llave Torx Clé Torx Torx Wrench
		Total Total	Eficaz Efficace Effective									
AHM15-AP16-D35x93-A27-Z0306-H	●	6	3	15	35	93	27	8	50	AP. 1604..	4015-M4x11	80-T15
AHM30-AP16-D35x87-A27-Z0306-H	●	6	3	30	35	87	27	15	50			
AHM45-AP16-D35x77-A27-Z0306-H	●	6	3	45	35	77	27	21.5	50			
AHM60-AP16-D35x65-A22-Z0306-H	●	6	3	60	35	65	22	26.5	50			
AHM75-AP16-D35x50-A22-Z0306-H	●	6	3	75	35	50	22	29.5	50			

R: Derecha / Droite / Right L: Izquierda / Gauche / Left

● En Existencia / En stock / In Stock ○ Artículo sin Existencia / Indisponible en Stock / Non Stock Item
 Compatible con el Inserto ISO. / Compatible avec ISO Plaquettes. / Compatible with ISO Insert.

Ejemplo de Pedido / Exemple de Commande / Ordering Example

1 Piezas / pcs. / pcs. ACM45-SP1104-D12x26-W20-L150-Z01

Cálculo de Corte : S 369 / Calcul de Coupe : P 369 / Cutting Calculation : 369

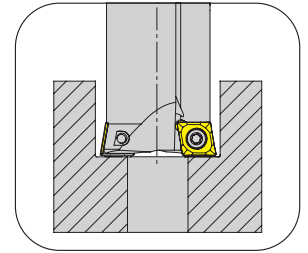
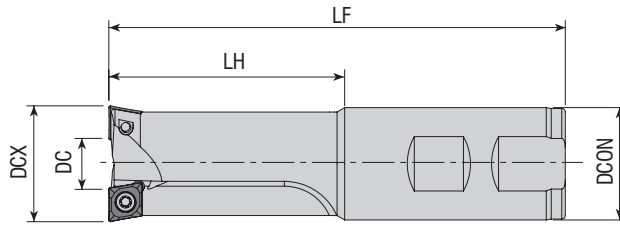

Código del Inserto Le Code de Commande Ordering Code	Stock Stock Stock	Dimension (mm) Dimension (mm) Dimension (mm)						Para Tornillos Pour Vis For Screws	Inserto Plaque Insert	Recambios / Pièces de Rechange / Spare Parts	
		DC	DCX	DCON	LH	LF	Tornillo Vis Screw			Llave Torx Clé Torx Torx Wrench	
ACBM-CC06-D17X6-W16-L150-Z02	●	6	17	16	30	150	-	CC.. 060204		3008-M2.5x6	80-T08
ACBM-CC06-D18X7-W16-L100-Z02-H	●	7	18	16	32	100	M10				
ACBM-CC06-D18X7-W16-L160-Z02-H	●	7	18	16	32	160	M10				
ACBM-CC06-D20X9-W20-L100-Z02-H	●	9	20	20	40	100	M12				
ACBM-CC06-D20X9-W20-L160-Z02-H	●	9	20	20	38	160	M12				
ACBM-CC09-D26X8.5-W25-L130-Z02-H	●	8.5	26	25	50	130	M16	CC.. 09T304		4015-M3.5x9	80-T15
ACBM-CC09-D26X8.5-W25-L200-Z02-H	●	8.5	26	25	50	200	M16				
ACBM-CC09-D30X12.5-W32-L130-Z02-H	●	12.5	30	32	65	130	-				
ACBM-CC09-D33X15.5-W32-L130-Z02-H	●	15.5	33	32	65	130	M20				
ACBM-CC09-D33X15.5-W32-L200-Z02-H	●	15.5	33	32	65	200	M20				
ACBM-SP06-D15X4-W16-L160-Z02-H	●	4	15	16	80	160	M8	SP. 060204	3007-M2.2x5	80-T07	

R: Derecha / Droite / Right L: Izquierda / Gauche / Left

● En Existencia / En stock / In Stock ○ Artículo sin Existencia / Indisponible en Stock / Non Stock Item
 Compatible con el Inserto ISO. / Compatible avec ISO Plaquettes. / Compatible with ISO Insert.

Ejemplo de Pedido / Exemple de Commande / Ordering Example

1 Piezas / pcs. / pcs. ACBM-CC06-D17X6-W16-L150-Z02

Cálculo de Corte : S 369 / Calcul de Coupe : P 369 / Cutting Calculation : 369



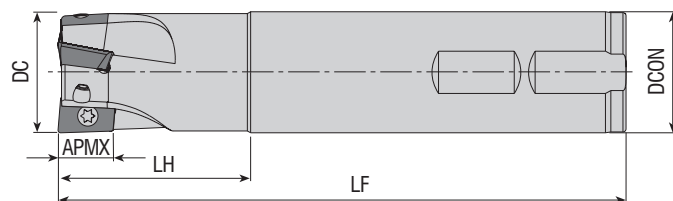

Código del Inserto Le Code de Commande Ordering Code	Stock Stock Stock	Dimension (mm) Dimension (mm) Dimension (mm)						Inserto Plaqueette Insert	Recambios / Pièces de Rechange / Spare Parts				
		DC	ZEFP	DCON	LF	LH	APMX		Tornillo Vis Screw	Llave Torx Clé Torx Torx Wrench			
AEM90-AD1505-D25-W25-L150-Z02	●	25	2	25	150	50	14.30						
AEM90-AD1505-D30-W25-L150-Z03	●	30	3	25	150	40	14.30				AD.. 1505..	4015-M4x9	80-T15
AEM90-AD1505-D32-W32-L150-Z03	●	32	3	32	150	50	14.30						

Compatible con el Inserto ISCR. / Compatible avec ISCR Plaquettes. / Compatible with ISCR Insert.

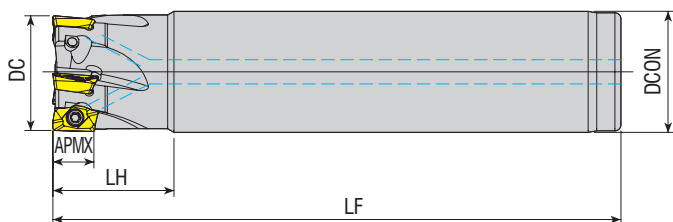

Código del Inserto Le Code de Commande Ordering Code	Stock Stock Stock	Dimension (mm) Dimension (mm) Dimension (mm)						Inserto Plaqueette Insert	Recambios / Pièces de Rechange / Spare Parts		
		DC	ZEFP	DCON	LF	LH	APMX		Tornillo Vis Screw	Llave Torx Clé Torx Torx Wrench	
AEM90-AD07-D10-C08-L90-Z02-H	●	10	2	8	90	16	6				
AEM90-AD07-D10-C10-L80-Z02-H	●	10	2	10	80	16	6				
AEM90-AD07-D12-C10-L80-Z03-H	●	12	3	10	80	18	6				
AEM90-AD07-D12-C12-L90-Z03-H	●	12	3	12	90	18	6				
AEM90-AD07-D16-C16-L110-Z04-H	●	16	4	16	110	19	6				
AEM90-AD07-D20-C20-L125-Z05-H	●	20	5	20	125	20	6				
AEM90-AD07-D25-C25-L140-Z06-H	●	25	6	25	140	24	6	ADMX 0702..			
AEM90-AD11-D16-C16-L135-Z02-H	●	16	2	16	135	24	9				
AEM90-AD11-D18-C16-L135-Z02-H	●	18	2	16	135	15	9				
AEM90-AD11-D18-C16-L160-Z02-H	●	18	2	16	160	15	9				
AEM90-AD11-D20-C20-L150-Z02-H	●	20	2	20	150	50	9				
AEM90-AD11-D20-C20-L150-Z03-H	●	20	3	20	150	50	9				
AEM90-AD11-D22-C20-L150-Z03-H	●	22	3	20	150	15	9	ADMX 11T30..			
AEM90-AD11-D22-C20-L200-Z03-H	●	22	3	20	200	15	9				
AEM90-AD11-D25-C25-L170-Z03-H	●	25	3	25	170	50	9				
AEM90-AD11-D25-C25-L170-Z04-H	●	25	4	25	170	50	9				
AEM90-AD11-D28-C25-L165-Z04-H	●	28	4	25	165	17	9				
AEM90-AD11-D28-C25-L200-Z04-H	●	28	4	25	200	17	9				
AEM90-AD11-D30-C25-L165-Z04-H	●	30	4	25	165	19	9	3008-M2.5x5			
AEM90-AD11-D30-C25-L200-Z04-H	●	30	4	25	200	19	9				
AEM90-AD11-D32-C32-L195-Z05-H	●	32	5	32	195	50	9				3008-M2.5x6

R: Derecha / Droite / Right L: Izquierda / Gauche / Left

● En Existencia / En stock / In Stock ○ Artículo sin Existencia / Indisponible en Stock / Non Stock Item
 Compatible con el Inserto PRMT. / Compatible avec PRMT Plaquettes. / Compatible with PRMT Insert.

Ejemplo de Pedido / Exemple de Commande / Ordering Example

1 Piezas / pcs. / pcs. AEM90-AD1505-D25-W25-L150-Z02
 Cálculo de Corte : S 369 / Calcul de Coupe : P 369 / Cutting Calculation : 369

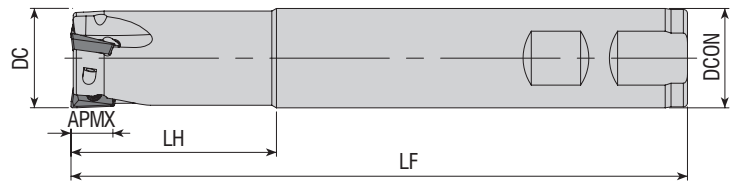

Código del Inserto Le Code de Commande Ordering Code	Stock Stock Stock	Dimension (mm) Dimension (mm) Dimension (mm)						Inserto Plaquette Insert	Recambios / Pièces de Rechange / Spare Parts		
		DC	ZEFP	DCON	LF	LH	APMX		Tornillo Vis Screw	Llave Torx Cle Torx Torx Wrench	
AEM90-AD0803-D16-W16-L150-Z02	●	16	2	16	150	30	8	ADMT 0803..	3008-M2.5x5		
AEM90-AD0803-D17-W16-L150-Z02	●	17	2	16	150	30	8				
AEM90-AD0803-D17-W16-L200-Z02	●	17	2	16	200	30	8				
AEM90-AD0803-D20-W20-L150-Z03	●	20	3	20	150	30	8				
AEM90-AD0803-D21-W20-L200-Z03	●	21	3	20	200	30	8				
AEM90-AD10T3-D16-W16-L100-Z02-H	●	16	2	16	100	30	10	ADMT 10T3..	3008-M2.5x6	80-T08	
AEM90-AD10T3-D16-W16-L150-Z02	●	16	2	16	150	40	10				
AEM90-AD10T3-D16-C16-L200-Z02	●	16	2	16	200	50	10				
AEM90-AD10T3-D17-W16-L150-Z02	●	17	2	16	150	30	10				
AEM90-AD10T3-D17-W16-L200-Z02	●	17	2	16	200	30	10				
AEM90-AD10T3-D20-W20-L70-Z03	●	20	3	20	70	30	10				
AEM90-AD10T3-D20-W20-L100-Z03-H	●	20	3	20	100	30	10				
AEM90-AD10T3-D20-W20-L150-Z03	●	20	3	20	150	40	10				
AEM90-AD10T3-D20-C20-L150-Z03	●	20	3	20	150	40	10				
AEM90-AD10T3-D20-C20-L200-Z03	●	20	3	20	200	50	10				
AEM90-AD10T3-D25-W25-L100-Z03-H	●	25	3	25	100	30	10	ADMT 1204..	4010-M3x6	80-T10	
AEM90-AD10T3-D25-W25-L100-Z04-H	●	25	4	25	100	30	10				
AEM90-AD10T3-D25-W25-L150-Z03	●	25	3	25	150	50	10				
AEM90-AD1204-D20-W20-L150-Z02	●	20	2	20	150	50	12				
AEM90-AD1204-D21-C20-L150-Z02	●	21	2	20	150	30	12				
AEM90-AD1204-D22-C20-L150-Z02	●	22	2	20	150	30	12	ADMT 1606..	4015-M4x9	80-T15	
AEM90-AD1204-D25-W25-L150-Z03	●	25	3	25	150	50	12				
AEM90-AD1204-D26-W25-L180-Z03	●	26	3	25	180	30	12				
AEM90-AD1204-D32-W32-L150-Z04	●	32	4	32	150	50	12	ADMT 1606..	4015-M4x9	80-T15	
AEM90-AD1606-D25-W25-L150-Z02	●	25	2	25	150	50	15				
AEM90-AD1606-D32-W32-L150-Z03	●	32	3	32	150	50	15				

R: Derecha / Droite / Right L: Izquierda / Gauche / Left
 ● En Existencia / En stock / In Stock ○ Artículo sin Existencia / Indisponible en Stock / Non Stock Item
 Compatible con el Inserto WLTR. / Compatible avec WLTR Plaquettes. / Compatible with WLTR Insert.

Ejemplo de Pedido / Exemple de Commande / Ordering Example
 1 Piezas / pcs. / pcs. AEM90-AD0803-D16-W16-L150-Z02
 Cálculo de Corte : S 369 / Calcul de Coupe : P 369 / Cutting Calculation : 369

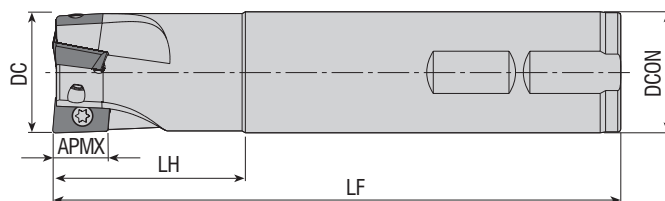

Código del Inserto Le Code de Commande Ordering Code	Stock Stock Stock	Dimension (mm) Dimension (mm) Dimension (mm)						Inserto Plaque Insert	Recambios / Pièces de Rechange / Spare Parts		
		DC	ZEP	DCON	LF	LH	APMX		Tornillo Vis Screw	Llave Torx Clé Torx Torx Wrench	
AEM90-AD1003-D16-C16-L150-Z02	●	16	2	16	150	30	8	ADMT 1003..	3008-M2.5x5	80-T08	
AEM90-AD1003-D17-C16-L150-Z02	●	17	2	16	150	25	8				
AEM90-AD1003-D20-C20-L200-Z03	●	20	3	20	200	50	8				
AEM90-AD1003-D21-C20-L150-Z03	●	21	3	20	150	25	8				
AEM90-AD1003-D21-C20-L200-Z03	●	21	3	20	200	25	8		3008-M2.5x6	80-T08	
AEM90-AD1003-D25-C25-L200-Z03	●	25	3	25	200	50	8				
AEM90-AD1003-D26-C25-L150-Z03	●	26	3	25	150	30	8				
AEM90-AD1003-D26-C25-L200-Z03	●	26	3	25	200	30	8				
AEM90-AD1505D-D25-W25-L150-Z02	●	25	2	25	150	50	14.3	ADKT 1505..	4015-M4x9	80-T15	
AEM90-AD1505D-D32-W32-L150-Z03	●	32	3	32	150	50	14.3		4015-M4x11		

Compatible con el Inserto DJT. / Compatible avec DJT Plaquettes. / Compatible with DJT Insert.

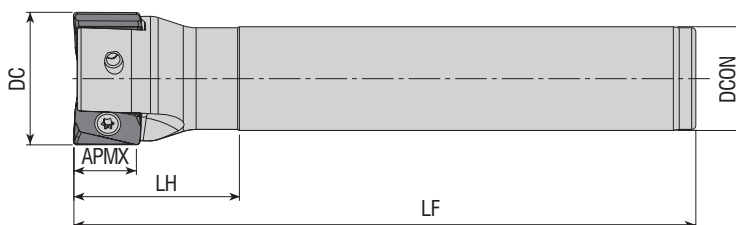

Código del Inserto Le Code de Commande Ordering Code	Stock Stock Stock	Dimension (mm) Dimension (mm) Dimension (mm)						Inserto Plaque Insert	Recambios / Pièces de Rechange / Spare Parts		
		DC	ZEP	DCON	LF	LH	APMX		Tornillo Vis Screw	Llave Torx Clé Torx Torx Wrench	
AEM90-AN11-D22-W20-L150-Z02	●	22	2	20	150	30	11	ANGX 1105..	4010-M3x8	80-T10	
AEM90-AN11-D25-W25-L150-Z02	●	25	2	25	150	40	11				
AEM90-AN11-D25-C25-L200-Z02	●	25	2	25	200	40	11				
AEM90-AN11-D26-W25-L150-Z02	●	26	2	25	150	40	11				
AEM90-AN11-D28-W25-L150-Z02	●	28	2	25	150	25	11				
AEM90-AN11-D32-W32-L150-Z03	●	32	3	32	150	50	11				
AEM90-AN11-D32-C32-L200-Z03	●	32	3	32	200	50	11				
AEM90-AN11-D40-W32-L150-Z04	●	40	4	32	150	40	11				

R: Derecha / Droite / Right L: Izquierda / Gauche / Left

● En Existencia / En stock / In Stock ○ Artículo sin Existencia / Indisponible en Stock / Non Stock Item
 Compatible con el Inserto ZCC. / Compatible avec ZCC Plaquettes. / Compatible with ZCC Insert.

Ejemplo de Pedido / Exemple de Commande / Ordering Example

1 Piezas / pcs. / pcs. AEM90-AD1003-D16-C16-L150-Z02
 Cálculo de Corte : S 369 / Calcul de Coupe : P 369 / Cutting Calculation : 369

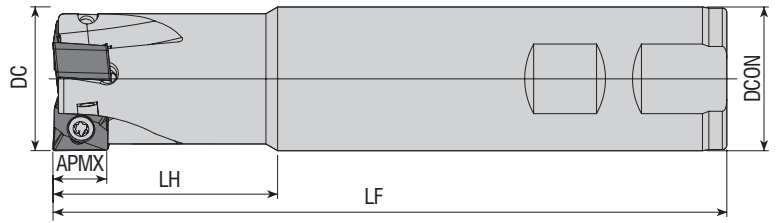

Código del Inserto Le Code de Commande Ordering Code	Stock Stock	Dimension (mm) Dimension (mm) Dimension (mm)						Inserto Plaquette Insert	Recambios / Pièces de Rechange / Spare Parts		
		DC	ZEFP	DCON	LF	LH	APMX		Tornillo Vis Screw	Llave Torx Clé Torx Torx Wrench	
AEM90-AN1207-D25-W25-L150-Z02	●	25	2	25	150	40	10	ANKX 1207..		4015-M4x11	
AEM90-AN1207-D32-W32-L150-Z03	●	32	3	32	150	50	10				
AEM90-AN1207-D40-W32-L150-Z04	●	40	4	32	150	40	10				

Compatible con el Inserto XTC-GSC. / Compatible avec XTC-GSC Plaquettes. / Compatible with XTC-GSC Insert.

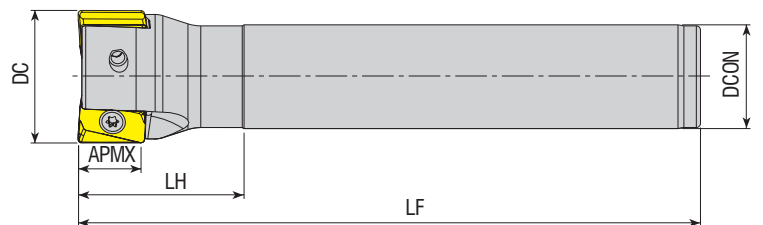

Código del Inserto Le Code de Commande Ordering Code	Stock Stock	Dimension (mm) Dimension (mm) Dimension (mm)						Inserto Plaquette Insert	Recambios / Pièces de Rechange / Spare Parts		
		DC	ZEFP	DCON	LF	LH	APMX		Tornillo Vis Screw	Llave Torx Clé Torx Torx Wrench	
AEM90-AN1607-D32-C25-L150-Z02	●	32	2	25	150	50	15	AN.X 1607..		4015-M4x11	
AEM90-AN1607-D40-C32-L150-Z03	●	40	3	32	150	50	15				

R: Derecha / Droite / Right L: Izquierda / Gauche / Left

● En Existencia / En stock / In Stock ○ Artículo sin Existencia / Indisponible en Stock / Non Stock Item
 Compatible con el Inserto TGTC. / Compatible avec TGTC Plaquettes. / Compatible with TGTC Insert.

Ejemplo de Pedido / Exemple de Commande / Ordering Example

1 Piezas / pcs. / pcs. AEM90-AN1207-D25-W25-L150-Z02

Cálculo de Corte : S 369 / Calcul de Coupe : P 369 / Cutting Calculation : 369

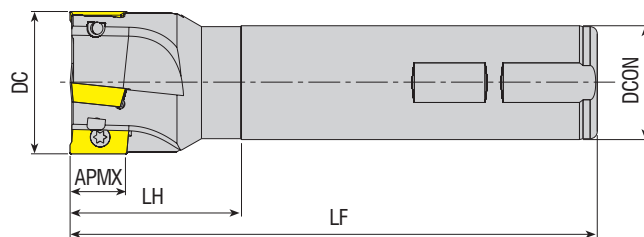

Código del Inserto Le Code de Commande Ordering Code	Stock Stock Stock	Dimension (mm) Dimension (mm) Dimension (mm)						Inserto Plaquette Insert	Recambios / Pièces de Rechange / Spare Parts		
		DC	ZEFP	DCON	LF	LH	APMX		Tornillo Vis Screw	Llave Torx Clé Torx Torx Wrench	
AEM90-AP06-D10-C10-L120-Z02	●	10	2	10	120	20	5.6	APMT 0602.. Para Inserto KRLY. Pour KRLY Plaquettes. For KRLY Insert.	3006-M1.8x4	80-T06	
AEM90-AP06-D12-C12-L120-Z02	●	12	2	12	120	20	5.6				
AEM90-AP0903-D12-C16-L080-Z01-H	●	12	1	16	80	30	9	APMT 0903.. Compatible con el Inserto KRLY. Compatible avec KRLY Plaquettes. FOR KRLY INSERT.	3008-M2.5x5	80-T08	
AEM90-AP0903-D16-C16-L090-Z02	●	16	2	16	90	30	9				
AEM90-AP0903-D16-C16-L150-Z02	●	16	2	16	150	30	9				
AEM90-AP0903-D17-C16-L150-Z02	●	17	2	16	150	30	9				
AEM90-AP0903-D18-C16-L090-Z02-H	●	18	2	16	90	30	9				
AEM90-AP0903-D20-C20-L110-Z03	●	20	3	20	110	30	9				
AEM90-AP0903-D20-C20-L150-Z02	●	20	2	20	150	30	9				
AEM90-AP0903-D20-C20-L200-Z02	●	20	2	20	200	100	9				
AEM90-AP0903-D21-C20-L150-Z02	●	21	2	20	150	30	9				
AEM90-AP0903-D25-C25-L120-Z03	●	25	3	25	120	30	9				
AEM90-AP0903-D25-C25-L150-Z03	●	25	3	25	150	30	9				
AEM90-AP0903-D25-C25-L200-Z02	●	25	2	25	200	100	9				
AEM90-AP09-D16-C16-L100-Z02-H	●	16	2	16	100	30	8.8	APKT 09T3.. Compatible con el Inserto TGTC. Compatible avec TGTC Plaquettes. FOR TGTC INSERT.	3008-M2.5x5	80-T08	
AEM90-AP09-D16-C15-L150-Z02	●	16	2	15	150	25	8.8				
AEM90-AP09-D16-W16-L150-Z02-H	●	16	2	16	150	25	8.8				
AEM90-AP09-D16-C16-L200-Z02-H	●	16	2	16	200	100	8.8				
AEM90-AP09-D17-C16-L150-Z02	●	17	2	16	150	25	8.8				
AEM90-AP09-D17-C16-L180-Z02-H	●	17	2	16	180	25	8.8				
AEM90-AP09-D20-C20-L150-Z03-H	●	20	3	20	150	50	8.8				
AEM90-AP09-D20-C20-L200-Z03-H	●	20	3	20	200	100	8.8				
AEM90-AP09-D20-C20-L250-Z02-H	●	20	2	20	250	150	8.8				
AEM90-AP09-D21-C20-L150-Z03	●	21	3	20	150	25	8.8				
AEM90-AP09-D26-C25-L150-Z04	●	26	4	25	150	30	8.8				
AEM90-AP10-D10-C10-L100-Z01	●	10	1	10	100	20	10	AP. 1003.. Compatible con el Inserto ISO. Compatible avec ISO Plaquettes. FOR ISO INSERT.	3008-M2.5x5		
AEM90-AP10-D12-C16-L100-Z01-H	●	12	1	16	100	30	10				
AEM90-AP10-D12-W16-L100-Z01-H	●	12	1	16	100	30	10				
AEM90-AP10-D12-W16-L150-Z01	●	12	1	16	150	38	10				
AEM90-AP10-D14-W16-L100-Z01-H	●	14	1	16	100	30	10				
AEM90-AP10-D14-W16-L150-Z01	●	14	1	16	150	38	10				
AEM90-AP10-D16-C16-L100-Z02-H	●	16	2	16	100	30	10				
AEM90-AP10-D16-W16-L100-Z02-H	●	16	2	16	100	30	10				
AEM90-AP10-D16-W16-L200-Z02	●	16	2	16	200	100	10				
AEM90-AP10-D16-C16-L120-Z02-H	●	16	2	16	120	30	10				



R: Derecha / Droite / Right L: Izquierda / Gauche / Left

● En Existencia / En stock / In Stock ○ Artículo sin Existencia / Indisponible en Stock / Non Stock Item

Ejemplo de Pedido / Exemple de Commande / Ordering Example

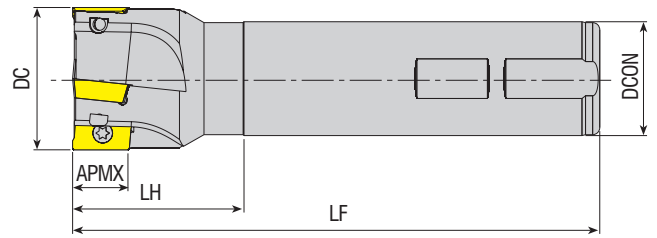
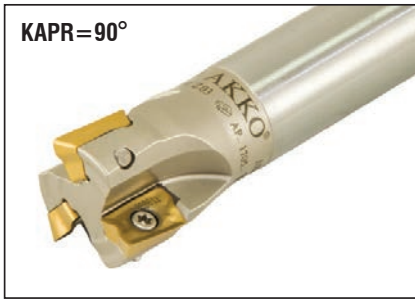
1 Piezas / pcs. / pcs. AEM90-AP06-D10-C10-L120-Z02
Cálculo de Corte : S 369 / Calcul de Coupe : P 369 / Cutting Calculation : 369



Código del Inserto Le Code de Commande Ordering Code	Stock Stock Stock	Dimension (mm) Dimension (mm) Dimension (mm)						Inserto Plaquette Insert	Recambios / Pièces de Rechange / Spare Parts	
		DC	ZEPF	DCON	LF	LH	APMX		Tornillo Vis Screw	Llave Torx Clé Torx Torx Wrench
AEM90-AP10-D16-C16-L150-Z02	●	16	2	16	150	50	10	 AP. 1003.. Compatible con el Inserto ISO. Compatible avec ISO Plaquettes. FOR ISO INSERT.	 3008-M2.5x5	 80-T08
AEM90-AP10-D16-C16-L150-Z02-H	●	16	2	16	150	50	10			
AEM90-AP10-D16-W16-L150-Z02	●	16	2	16	150	50	10			
AEM90-AP10-D16-C16-L200-Z02	●	16	2	16	200	100	10			
AEM90-AP10-D16-C16-L200-Z02-H	●	16	2	16	200	100	10			
AEM90-AP10-D16-C16-L250-Z02	●	16	2	16	250	150	10			
AEM90-AP10-D18-W16-L100-Z02-H	●	18	2	16	100	30	10			
AEM90-AP10-D18-W16-L150-Z02	●	18	2	16	150	30	10			
AEM90-AP10-D20-C20-L100-Z03-H	●	20	3	20	100	30	10			
AEM90-AP10-D20-W20-L100-Z03-H	●	20	3	20	100	30	10			
AEM90-AP10-D20-C20-L120-Z03-H	●	20	3	20	120	30	10			
AEM90-AP10-D20-C20-L150-Z03	●	20	3	20	150	50	10			
AEM90-AP10-D20-C20-L150-Z03-H	●	20	3	20	150	50	10			
AEM90-AP10-D20-W20-L150-Z03	●	20	3	20	150	50	10			
AEM90-AP10-D20-C20-L200-Z02	●	20	2	20	200	100	10			
AEM90-AP10-D20-C20-L200-Z03-H	●	20	3	20	200	100	10			
AEM90-AP10-D20-C20-L250-Z02	●	20	2	20	250	150	10			
AEM90-AP10-D20-C20-L250-Z02-H	●	20	2	20	250	150	10			
AEM90-AP10-D21-C20-L200-Z03	●	21	3	20	200	30	10			
AEM90-AP10-D21-W20-L150-Z03	●	21	3	20	150	30	10			
AEM90-AP10-D22-W20-L100-Z03-H	●	22	3	20	100	30	10			
AEM90-AP10-D22-W20-L150-Z03	●	22	3	20	150	30	10			
AEM90-AP10-D23-W20-L150-Z03	●	23	3	20	150	30	10			
AEM90-AP10-D24-W20-L150-Z03	●	24	3	20	150	30	10			
AEM90-AP10-D25-W25-L100-Z04-H	●	25	4	25	100	30	10			
AEM90-AP10-D25-C25-L100-Z03-H	●	25	3	25	100	30	10			
AEM90-AP10-D25-W25-L100-Z03-H	●	25	3	25	100	30	10			
AEM90-AP10-D25-C25-L120-Z03-H	●	25	3	25	120	30	10			
AEM90-AP10-D25-C25-L150-Z03	●	25	3	25	150	50	10			
AEM90-AP10-D25-W25-L150-Z03	●	25	3	25	150	50	10			
AEM90-AP10-D25-C25-L200-Z02	●	25	2	25	200	100	10			
AEM90-AP10-D25-C25-L200-Z03	●	25	3	25	200	100	10			
AEM90-AP10-D25-C25-L250-Z02	●	25	2	25	250	100	10			
								3008-M2.5x6		

R: Derecha / Droite / Right L: Izquierda / Gauche / Left





● En Existencia / En stock / In Stock ○ Artículo sin Existencia / Indisponible en Stock / Non Stock Item

Ejemplo de Pedido / Exemple de Commande / Ordering Example

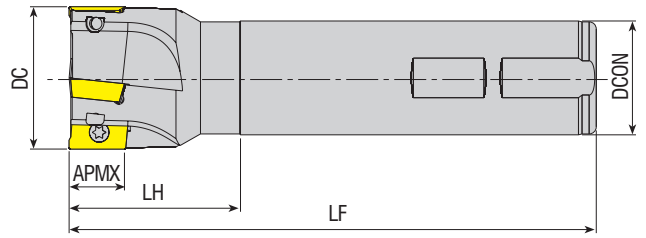
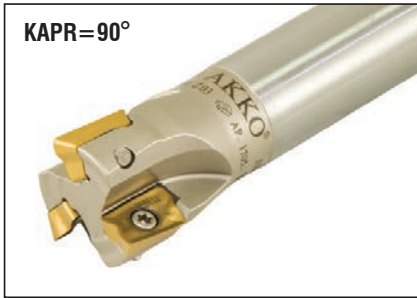
1 Piezas / pcs. / pcs. AEM90-AP10-D16-C16-L150-Z02

Cálculo de Corte : S 369 / Calcul de Coupe : P 369 / Cutting Calculation : 369





Código del Inserto Le Code de Commande Ordering Code	Stock Stock Stock	Dimension (mm) Dimension (mm) Dimension (mm)						Inserto Plaquette Insert	Recambios / Pièces de Rechange / Spare Parts	
		DC	ZEFP	DCON	LF	LH	APMX		Tornillo Vis Screw	Llave Torx Clé Torx Torx Wrench
AEM90-AP10-D30-C25-L100-Z04-H	●	30	4	25	100	30	10	 AP. 1003.. Compatible con el Inserto ISO. Compatible avec ISO Plaquettes. FOR ISO INSERT.	 3008-M2.5x6	
AEM90-AP10-D30-C25-L120-Z04-H	●	30	4	25	120	30	10			
AEM90-AP10-D30-C25-L150-Z04	●	30	4	25	150	30	10			
AEM90-AP10-D32-C25-L100-Z04-H	●	32	4	25	100	35	10			
AEM90-AP10-D32-C25-L120-Z04-H	●	32	4	25	120	35	10			
AEM90-AP10-D32-C25-L150-Z04	●	32	4	25	150	35	10			
AEM90-AP10-D32-W25-L150-Z04	●	32	4	25	150	35	10			
AEM90-AP10-D32-C32-L130-Z05	●	32	5	32	130	30	10			
AEM90-AP10-D32-W32-L150-Z04	●	32	4	32	150	50	10			
AEM90-AP10-D40-W32-L150-Z05	●	40	5	32	150	40	10			
AEM90-AP10D-D16-W16-L150-Z02	●	16	2	16	150	50	10	 AP. 1003.. Para Inserto DJT. POUR DJT PLAQUETTES / FOR DJT INSERT	3008-M2.5x5	80-T08
AEM90-AP10D-D20-W20-L150-Z03	●	20	3	20	150	50	10			
AEM90-AP10D-D25-W20-L150-Z03	●	25	3	20	150	30	10			
AEM90-AP100-D16-C15-L150-Z02	●	16	2	15	150	30	10			
AEM90-AP100-D21-C20-L150-Z03	●	21	3	20	150	30	10			
AEM90-AP100-D26-C25-L150-Z04	●	26	4	25	150	35	10			
AEM90-AP100-D33-C32-L200-Z05	●	33	5	32	200	50	10			
AEM90-AP10S-D16-W16-L150-Z02	●	16	2	16	150	26	10			
AEM90-AP10S-D20-W20-L150-Z02	●	20	2	20	150	26	10			
AEM90-AP10S-D25-W25-L150-Z03	●	25	3	25	150	26	10			
AEM90-AP11-D16-C16-L150-Z02	●	16	2	16	150	50	11	 AP. 11T3.. Compatible con el Inserto ZCC. Compatible avec ZCC Plaquettes. FOR ZCC INSERT.	3008-M2.5x6	80-T08
AEM90-AP11-D16-C16-L150-Z02-H	●	16	2	16	150	50	11			
AEM90-AP11-D16-W16-L150-Z02	●	16	2	16	150	50	11			
AEM90-AP11-D16-W16-L150-Z02-H	●	16	2	16	150	50	11			
AEM90-AP11-D16-C16-L200-Z02	●	16	2	16	200	100	11			
AEM90-AP11-D17-C16-L150-Z02	●	17	2	16	150	30	11			
AEM90-AP11-D17-C16-L200-Z02	●	17	2	16	200	30	11			
AEM90-AP11-D20-C20-L150-Z03	●	20	3	20	150	50	11			
AEM90-AP11-D20-W20-L150-Z03	●	20	3	20	150	50	11			
AEM90-AP11-D20-W20-L150-Z03-H	●	20	3	20	150	50	11			
AEM90-AP11-D20-C20-L200-Z03	●	20	3	20	200	100	11			
AEM90-AP11-D21-C20-L150-Z03	●	21	3	20	150	30	11			
AEM90-AP11-D21-W20-L150-Z03	●	21	3	20	150	30	11			
AEM90-AP11-D21-W20-L150-Z03-H	●	21	3	20	150	30	11			
AEM90-AP11-D21-C20-L200-Z03	●	21	3	20	200	30	11			
AEM90-AP11-D25-C25-L150-Z03	●	25	3	25	150	50	11			
AEM90-AP11-D25-W25-L150-Z03	●	25	3	25	150	50	11			
AEM90-AP11-D25-W25-L150-Z03-H	●	25	3	25	150	50	11			
AEM90-AP11-D26-C25-L150-Z03	●	26	3	25	150	35	11			
AEM90-AP11-D26-C24-L150-Z03	●	26	3	24	150	35	11			
AEM90-AP11-D32-W25-L150-Z04	●	32	4	25	150	35	11			
AEM90-AP11-D32-W32-L150-Z03-H	●	32	3	32	150	50	11			
AEM90-AP11-D32-W32-L150-Z04	●	32	4	32	150	50	11			

R: Derecha / Droite / Right L: Izquierda / Gauche / Left ● En Existencia / En stock / In Stock ○ Artículo sin Existencia / Indisponible en Stock / Non Stock Item Ejemplo de Pedido / Exemple de Commande / Ordering Example

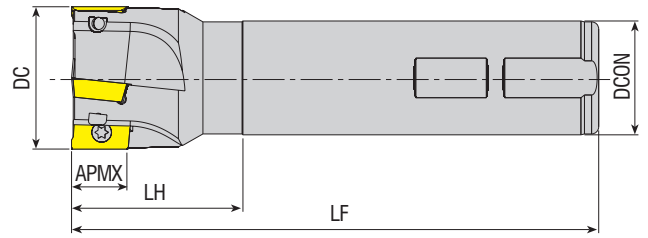
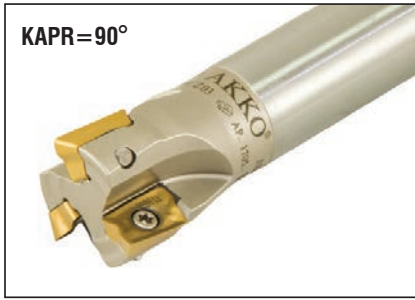



Código del Inserto Le Code de Commande Ordering Code	Stock Stock Stock	Dimension (mm) Dimension (mm) Dimension (mm)						Inserto Plaquette Insert	Recambios / Pièces de Rechange / Spare Parts		
		DC	ZEFP	DCON	LF	LH	APMX		Tornillo Vis Screw	Llave Torx Clé Torx Torx Wrench	
AEM90-AP1135A-D14-C16-L150-Z01	●	14	1	16	150	40	9.5	APMT 1135.. Compatible con el Inserto ACTKH. Compatible avec ACTKH Plaquettes. FOR ACTKH INSERT.	3008-M2.5x5	 	
AEM90-AP1135A-D16-C16-L150-Z02	●	16	2	16	150	40	9.5				
AEM90-AP1135A-D16-C16-L200-Z02	●	16	2	16	200	100	9.5				
AEM90-AP1135A-D16-C16-L250-Z02	●	16	2	16	250	150	9.5				
AEM90-AP1135A-D17-C16-L180-Z02	●	17	2	16	180	30	9.5				
AEM90-AP1135A-D20-C20-L150-Z03	●	20	3	20	150	50	9.5				
AEM90-AP1135A-D20-C20-L200-Z02	●	20	2	20	200	100	9.5		3008-M2.5x6		
AEM90-AP1135A-D21-C20-L180-Z02	●	21	2	20	180	30	9.5				
AEM90-AP1135A-D25-C25-L200-Z03	●	25	3	25	200	100	9.5				
AEM90-AP1135A-D26-C25-L250-Z02	●	26	2	25	250	35	9.5				
AEM90-AP1135A-D33-C32-L250-Z02	●	33	2	32	250	35	9.5				
AEM90-AP110-D16-C15-L150-Z02	●	16	2	15	150	30	11				AP. 1135.. Para Inserto B.OKE. POUR B.OKE PLAQUETTES. FOR B.OKE INSERT.
AEM90-AP110-D21-C20-L150-Z03	●	21	3	20	150	30	11	3008-M2.5x6			
AEM90-AP110-D26-C25-L150-Z04	●	26	4	25	150	35	11	3008-M2.5x6			
AEM90-AP110-D33-C32-L200-Z05	●	33	5	32	200	50	11	3008-M3x5			
AEM90-APK11G-D16-W16-L150-Z02	●	16	2	16	150	26	11	3008-M3x6			
AEM90-APK11G-D20-W20-L150-Z03	●	20	3	20	150	26	11	AP. 1135.. Compatible con el Inserto XTC-GSC. Compatible avec XTC-GSC Plaquettes. FOR XTC-GSC INSERT.	80-T08		
AEM90-APK11G-D25-W25-L150-Z03	●	25	3	25	150	26	11				
AEM90-AP1135-D16-W16-L110-Z02-H	●	16	2	16	110	30	9.5				
AEM90-AP1135-D16-W16-L150-Z02	●	16	2	16	150	50	9.5				
AEM90-AP1135-D20-W20-L125-Z03-H	●	20	3	20	125	30	9.5				
AEM90-AP1135-D20-W20-L150-Z03	●	20	3	20	150	50	9.5				
AEM90-AP1135-D25-W25-L125-Z04-H	●	25	4	25	125	30	9.5				
AEM90-AP1135-D25-W25-L200-Z04-H	●	25	4	25	200	100	9.5				
AEM90-AP1135-D32-W32-L125-Z05-H	●	32	5	32	125	30	9.5				
AEM90-AP1135-D32-W32-L200-Z04-H	●	32	4	32	200	100	9.5				
AEM90-AP1135Y-D16-C16-L120-Z02-H	●	16	2	16	120	30	9.5			APMT 1135.. Compatible con el Inserto YG. Compatible avec YG Plaquettes. FOR YG INSERT.	3008-M2.5x6
AEM90-AP1135Y-D16-W16-L150-Z02	●	16	2	16	150	50	9.5				
AEM90-AP1135Y-D17-C16-L150-Z02	●	17	2	16	150	30	9.5				
AEM90-AP1135Y-D20-C20-L120-Z02	●	20	2	20	120	30	9.5				
AEM90-AP1135Y-D20-W20-L150-Z03	●	20	3	20	150	50	9.5				
AEM90-AP1135Y-D21-C20-L150-Z03	●	21	3	20	150	30	9.5				
AEM90-AP1135Y-D25-W25-L150-Z03	●	25	3	25	150	50	9.5				
AEM90-AP1135Y-D25-C25-L150-Z04-H	●	25	4	25	150	30	9.5				
AEM90-AP1135Y-D26-C25-L150-Z03	●	26	3	25	150	35	9.5				
AEM90-AP1135Y-D32-W25-L110-Z04	●	32	4	25	110	35	9.5				
AEM90-AP1204-D20-C20-L150-Z02	●	20	2	20	150	30	12	AP. 1204.. Compatible con el Inserto TGTC. Compatible avec TGTC Plaquettes. FOR TGTC INSERT.	3010-M3.5x7		
AEM90-AP1204-D21-C20-L150-Z02	●	21	2	20	150	30	12				
AEM90-AP1204-D21-C20-L200-Z02	●	21	2	20	200	30	12				
AEM90-AP1204-D25-C25-L150-Z03	●	25	3	25	150	40	12				
AEM90-AP1204-D26-C25-L250-Z02	●	26	2	25	250	35	12				
AEM90-AP1204-D32-C25-L150-Z03	●	32	3	25	150	35	12			3010-M3.5x9	

R: Derecha / Droite / Right L: Izquierda / Gauche / Left



● En Existencia / En stock / In Stock ○ Artículo sin Existencia / Indisponible en Stock / Non Stock Item

Ejemplo de Pedido / Exemple de Commande / Ordering Example

1 Piezas / pcs. / pcs. AEM90-AP1135A-D14-C16-L150-Z01

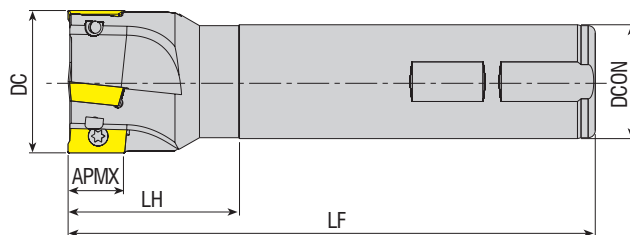
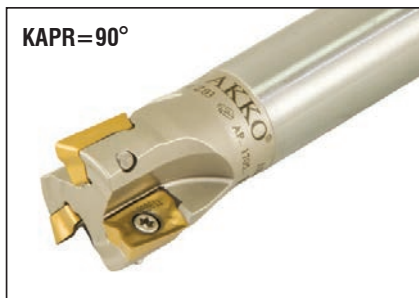
Cálculo de Corte : S 369 / Calcul de Coupe : P 369 / Cutting Calculation : 369



Código del Inserto Le Code de Commande Ordering Code	Stock Stock Stock	Dimension (mm) Dimension (mm) Dimension (mm)						Inserto Plaquette Insert	Recambios / Pièces de Rechange / Spare Parts		
		DC	ZEFP	DCON	LF	LH	APMX		Tornillo Vis Screw	Llave Torx Clé Torx Torx Wrench	
AEM90-AP16-D25-C20-L100-Z02	●	25	2	20	100	35	16	 AP. 1604.. Compatible con el Inserto ISO. Compatible avec ISO Plaquettes. FOR ISO INSERT.	 4015-M4x9	 80-T15	
AEM90-AP16-D25-W25-L100-Z02-H	●	25	2	25	100	35	16				
AEM90-AP16-D25-W25-L150-Z02	●	25	2	25	150	50	16				
AEM90-AP16-D25-C25-L250-Z02	●	25	2	25	250	100	16				
AEM90-AP16-D28-W25-L100-Z03-H	●	28	3	25	100	40	16				
AEM90-AP16-D28-W25-L150-Z03	●	28	3	25	150	40	16				
AEM90-AP16-D30-W25-L110-Z03-H	●	30	3	25	110	40	16				
AEM90-AP16-D30-W25-L150-Z02	●	30	2	25	150	40	16				
AEM90-AP16-D30-W25-L150-Z03	●	30	3	25	150	40	16				
AEM90-AP16-D32-W32-L110-Z03-H	●	32	3	32	110	40	16				
AEM90-AP16-D32-C32-L150-Z03	●	32	3	32	150	50	16				
AEM90-AP16-D32-W25-L150-Z03	●	32	3	25	150	40	16				
AEM90-AP16-D32-W32-L150-Z03	●	32	3	32	150	50	16				
AEM90-AP16-D32-W32-L150-Z03-H	●	32	3	32	150	50	16				
AEM90-AP16-D32-C25-L200-Z03-H	●	32	3	25	200	40	16				
AEM90-AP16-D32-C32-L250-Z02	●	32	2	32	250	100	16				
AEM90-AP16-D32-C32-L250-Z03	●	32	3	32	250	100	16				
AEM90-AP16-D35-W32-L150-Z03	●	35	3	32	150	40	16				
AEM90-AP16-D36-W32-L110-Z03-H	●	36	3	32	110	40	16				
AEM90-AP16-D36-W32-L150-Z03	●	36	3	32	150	40	16				
AEM90-AP16-D40-W32-L110-Z04-H	●	40	4	32	110	40	16				
AEM90-AP16-D40-C32-L150-Z04	●	40	4	32	150	40	16				
AEM90-AP16-D40-W32-L150-Z04	●	40	4	32	150	40	16				
AEM90-AP16-D40-C32-L250-Z02	●	40	2	32	250	40	16				
AEM90-AP16-D40-C32-L250-Z04	●	40	4	32	250	40	16				
AEM90-AP16DJ-D25-W25-L150-Z02	●	25	2	25	150	50	16				AP. 1604.. Compatible con el Inserto DJT. Compatible avec DJT Plaquettes. FOR DJT INSERT.
AEM90-AP16DJ-D25-C25-L200-Z02	●	25	2	25	200	50	16				
AEM90-AP16DJ-D32-W32-L150-Z03	●	32	3	32	150	50	16				
AEM90-AP16DJ-D32-C32-L180-Z03	●	32	3	32	180	50	16				
AEM90-AP16DJ-D32-C32-L200-Z03	●	32	3	32	200	50	16				
AEM90-AP16L-D25-C25-L120-Z02-H	●	25	2	25	120	45	16	AP. 1604.. Compatible con el Inserto LMN. Compatible avec LMN Plaquettes. FOR LMN INSERT.	4015-M4x9	80-T15	
AEM90-AP16L-D25-C25-L150-Z02	●	25	2	25	150	55	16				
AEM90-AP16L-D25-C25-L200-Z02	●	25	2	25	200	55	16				
AEM90-AP16L-D25-C25-L250-Z02	●	25	2	25	250	100	16				
AEM90-AP16L-D30-W25-L120-Z03-H	●	30	3	25	120	40	16				
AEM90-AP16L-D32-C32-L120-Z03-H	●	32	3	32	120	45	16				
AEM90-AP16L-D32-C32-L150-Z03	●	32	3	32	150	55	16				
AEM90-AP16L-D32-C32-L200-Z03	●	32	3	32	200	55	16				
AEM90-AP16L-D32-C32-L250-Z03	●	32	3	32	250	100	16				
AEM90-AP16L-D40-C32-L120-Z04-H	●	40	4	32	120	40	16				
AEM90-AP16L-D40-C32-L150-Z04	●	40	4	32	150	40	16				
AEM90-AP16L-D40-C32-L200-Z04	●	40	4	32	200	40	16				
AEM90-AP16L-D40-C32-L250-Z04	●	40	4	32	250	40	16				

R: Derecha / Droite / Right L: Izquierda / Gauche / Left

● En Existencia / En stock / In Stock ○ Artículo sin Existencia / Indisponible en Stock / Non Stock Item

Ejemplo de Pedido / Exemple de Commande / Ordering Example

1 Piezas / pcs. / pcs. AEM90-AP16-D25-C20-L100-Z02

Cálculo de Corte : S 369 / Calcul de Coupe : P 369 / Cutting Calculation : 369

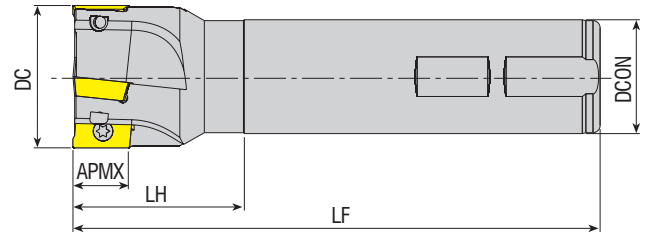
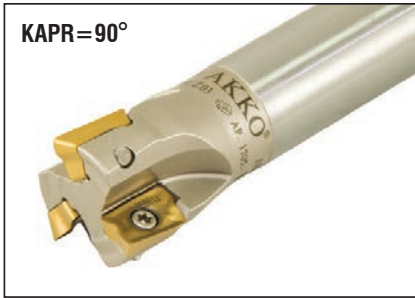

Código del Inserto Le Code de Commande Ordering Code	Stock Stock Stock	Dimension (mm) Dimension (mm) Dimension (mm)						Inserto Plaquette Insert	Recambios / Pièces de Rechange / Spare Parts	
		DC	ZEFP	DCON	LF	LH	APMX		Tornillo Vis Screw	Llave Torx Clé Torx Torx Wrench
AEM90-AP16P-D25-W25-L100-Z02-H	●	25	2	25	100	35	16			
AEM90-AP16P-D25-W25-L150-Z02	●	25	2	25	150	50	16			
AEM90-AP16P-D32-W32-L150-Z03	●	32	3	32	150	50	16	<i>AP. 1604.. Compatible con el Inserto PLBT. Compatible avec PLBT Plaquettes. FOR PLBT INSERT.</i>		
AEM90-AP16P-D32-C32-L250-Z02	●	32	2	32	250	100	16			
AEM90-AP16P-D40-W32-L150-Z04	●	40	4	32	150	50	16	<i>AP. 1604.. Compatible con el Inserto YG. Compatible avec YG Plaquettes. FOR YG INSERT.</i>	4015-M4x9	80-T15
AEM90-AP16Y-D25-C20-L100-Z02-H	●	25	2	20	100	35	16			
AEM90-AP16Y-D25-C25-L120-Z02	●	25	2	25	120	50	16	<i>AP. 1705.. Compatible con el Inserto TGTC-LMN. Compatible avec TGTC-LMN Plaquettes. FOR TGTC-LMN INSERT.</i>		
AEM90-AP16Y-D25-C25-L150-Z02	●	25	2	25	150	50	16			
AEM90-AP16Y-D25-C25-L250-Z02	●	25	2	25	250	100	16	<i>AP. 1705.. Compatible con el Inserto TGTC-LMN. Compatible avec TGTC-LMN Plaquettes. FOR TGTC-LMN INSERT.</i>		
AEM90-AP1705-D25-C25-L120-Z02	●	25	2	25	120	40	16			
AEM90-AP1705-D26-C25-L200-Z02	●	26	2	25	200	40	16	<i>AP. 1705.. Compatible con el Inserto TGTC-LMN. Compatible avec TGTC-LMN Plaquettes. FOR TGTC-LMN INSERT.</i>		
AEM90-AP1705-D26-C25-L250-Z02	●	26	2	25	250	40	16			
AEM90-AP1705-D26-C25-L300-Z02	○	26	2	25	300	40	16	<i>AP. 1705.. Compatible con el Inserto TGTC-LMN. Compatible avec TGTC-LMN Plaquettes. FOR TGTC-LMN INSERT.</i>		
AEM90-AP1705-D28-W25-L075-Z02	●	28	2	25	75	20	16			
AEM90-AP1705-D32-C25-L150-Z03	●	32	3	25	150	40	16	<i>AP. 1705.. Compatible con el Inserto TGTC-LMN. Compatible avec TGTC-LMN Plaquettes. FOR TGTC-LMN INSERT.</i>		
AEM90-AP1705-D33-C32-L250-Z03	●	33	3	32	250	40	16			
AEM90-AP1705-D33-C32-L300-Z02	●	33	2	32	300	40	16	<i>AP. 1705.. Compatible con el Inserto TGTC-LMN. Compatible avec TGTC-LMN Plaquettes. FOR TGTC-LMN INSERT.</i>		

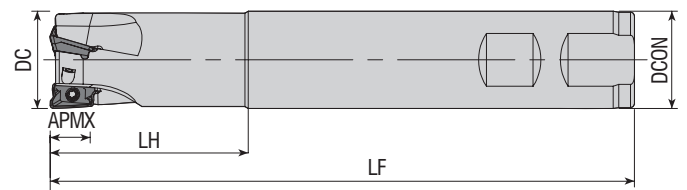

Código del Inserto Le Code de Commande Ordering Code	Stock Stock Stock	Dimension (mm) Dimension (mm) Dimension (mm)						Inserto Plaquette Insert	Recambios / Pièces de Rechange / Spare Parts	
		DC	ZEFP	DCON	LF	LH	APMX		Tornillo Vis Screw	Llave Torx Clé Torx Torx Wrench
AEM90-AO1236-D16-W16-L150-Z02	●	16	2	16	150	50	10			
AEM90-AO1236-D20-C20-L100-Z02	○	20	2	20	100	30	10			
AEM90-AO1236-D25-C25-L115-Z02	○	25	2	25	150	50	10	<i>AO.1236..</i>	3008-M2.5x6	80-T08
AEM90-AO1236-D25-W25-L150-Z03	●	25	3	25	150	50	10			
AEM90-AO1236-D32-W32-L150-Z04	●	32	4	32	150	50	10	<i>AO.1236..</i>		

R: Derecha / Droite / Right L: Izquierda / Gauche / Left

● En Existencia / En stock / In Stock ○ Artículo sin Existencia / Indisponible en Stock / Non Stock Item
Compatible con el Inserto MTSBH. / Compatible avec MTSBH Plaquettes. / Compatible with MTSBH Insert.

Ejemplo de Pedido / Exemple de Commande / Ordering Example
1 Piezas / pcs. / pcs. AEM90-AP16P-D25-W25-L100-Z02-H
Cálculo de Corte : S 369 / Calcul de Coupe : P 369 / Cutting Calculation : 369

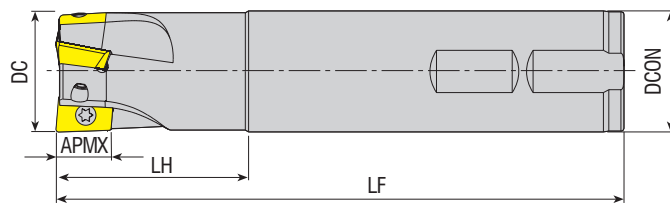





Código del Inserto Le Code de Commande Ordering Code	Stock Stock Stock	Dimension (mm) Dimension (mm) Dimension (mm)						Inserto Plaqueette Insert	Recambios / Pièces de Rechange / Spare Parts		
		DC	ZEPF	DCON	LF	LH	APMX		Tornillo Vis Screw	Llave Torx Clé Torx Torx Wrench	
AEM90-AX0602-D10-C09-L120-Z02	●	10	2	9	120	20	5.7	AX.. 0602	3006-M1.8x4	80-T06	
AEM90-AX0602-D10-C10-L080-Z02	●	10	2	10	80	20	5.7				
AEM90-AX0602-D10-C10-L120-Z02	●	10	2	10	120	20	5.7				
AEM90-AX0602-D12-C11-L120-Z02	●	12	2	11	120	20	5.7				
AEM90-AX0602-D12-C12-L080-Z02	●	12	2	12	80	20	5.7				
AEM90-AX0602-D12-C12-L120-Z02	●	12	2	12	120	20	5.7				
AEM90-AX0602-D14-C12-L120-Z03	●	14	3	12	120	20	5.7				
AEM90-AX0602-D16-W16-L120-Z04-H	●	16	4	16	120	20	5.7				
AEM90-AX0602-D16-W16-L150-Z04-H	●	16	4	16	150	20	5.7				
AEM90-AX0602-D20-W20-L120-Z05-H	●	20	5	20	120	25	5.7				
AEM90-AX0602-D20-W20-L150-Z05-H	●	20	5	20	150	25	5.7				
AEM90-AX0903-D16-C16-L120-Z02	●	16	2	16	120	30	8.8				AX.. 0903
AEM90-AX0903-D16-C16-L180-Z02	●	16	2	16	180	30	8.8				
AEM90-AX0903-D17-C16-L120-Z02	●	17	2	16	120	25	8.8				
AEM90-AX0903-D17-C16-L180-Z02	●	17	2	16	180	25	8.8				
AEM90-AX0903-D20-C20-L120-Z03	●	20	3	20	120	30	8.8				
AEM90-AX0903-D20-C20-L200-Z02	●	20	2	20	200	30	8.8				
AEM90-AX0903-D21-C20-L120-Z03	●	21	3	20	120	25	8.8				
AEM90-AX0903-D21-C20-L200-Z02	●	21	2	20	200	25	8.8				
AEM90-AX0903-D25-C25-L150-Z03	●	25	3	25	150	30	8.8				
AEM90-AX0903-D25-C25-L250-Z02	●	25	2	25	250	40	8.8				
AEM90-AX0903-D26-C25-L150-Z03	●	26	3	25	150	30	8.8				

R: Derecha / Droite / Right L: Izquierda / Gauche / Left
 ● En Existencia / En stock / In Stock ○ Artículo sin Existencia / Indisponible en Stock / Non Stock Item
 Compatible con el Inserto TGTC. / Compatible avec TGTC Plaquettes. / Compatible with TGTC Insert.

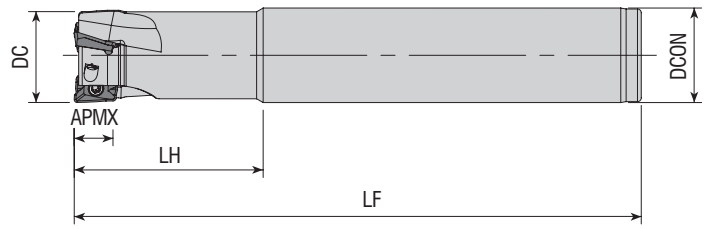
Ejemplo de Pedido / Exemple de Commande / Ordering Example
 1 Piezas / pcs. / pcs. AEM90-AX0602-D10-C09-L120-Z02
 Cálculo de Corte : S 369 / Calcul de Coupe : P 369 / Cutting Calculation : 369





Código del Inserto Le Code de Commande Ordering Code	Stock Stock Stock	Dimension (mm) Dimension (mm) Dimension (mm)						Inserto Plaquette Insert	Recambios / Pièces de Rechange / Spare Parts				
		DC	ZEFP	DCON	LF	LH	APMX		Tornillo Vis Screw	Llave Torx Clé Torx Torx Wrench			
AEM90-AX1235-D16-C14-L120-Z02-H	●	16	2	14	120	25	10						
AEM90-AX1235-D16-C15-L145-Z02-H	●	16	2	15	145	30	10				3108-M3x6		
AEM90-AX1235-D16-C16-L100-Z02-H	●	16	2	16	100	30	10				3008-M3x6		
AEM90-AX1235-D16-C16-L140-Z02-H	●	16	2	16	140	30	10				3108-M3x6		
AEM90-AX1235-D16-C16-L145-Z02-H	●	16	2	16	145	30	10				3008-M3x6		
AEM90-AX1235-D16-C16-L150-Z02	●	16	2	16	150	30	10				3108-M3x6		
AEM90-AX1235-D20-C19-L150-Z02-H	●	20	2	19	150	40	10				3008-M3x6		
AEM90-AX1235-D20-C20-L110-Z03-H	●	20	3	20	110	40	10				3108-M3x6		
AEM90-AX1235-D20-C20-L150-Z02	●	20	2	20	150	40	10				3008-M3x6		
AEM90-AX1235-D20-C20-L150-Z02-H	●	20	2	20	150	40	10				3108-M3x6		
AEM90-AX1235-D20-C20-L150-Z03	●	20	3	20	150	40	10				3008-M3x6		
AEM90-AX1235-D25-C20-L120-Z04-H	●	25	4	20	120	30	10				3108-M3x6		
AEM90-AX1235-D25-C20-L150-Z04-H	●	25	4	20	150	30	10				3008-M3x6		
AEM90-AX1235-D25-C24-L170-Z02-H	●	25	2	24	170	50	10				3108-M3x6		
AEM90-AX1235-D25-C25-L120-Z04-H	●	25	4	25	120	40	10				3008-M3x6		
AEM90-AX1235-D25-C25-L150-Z03	●	25	3	25	150	50	10				3108-M3x6		
AEM90-AX1235-D25-C25-L170-Z02-H	●	25	2	25	170	50	10				3008-M3x6		
AEM90-AX1235-D25-W25-L100-Z04-H	●	25	4	25	100	30	10				3108-M3x6		
AEM90-AX1235-D32-C32-L130-Z05-H	●	32	5	32	130	40	10				AX.T 1705..	4015-M4x9	80-T15
AEM90-AX1235-D32-C32-L180-Z02-H	●	32	2	32	180	50	10						
AEM90-AX1705-D25-C25-L150-Z02	●	25	2	25	150	50	14						
AEM90-AX1705-D28-W25-L115-Z02-H	●	28	2	25	115	35	14						
AEM90-AX1705-D32-C32-L150-Z03	●	32	3	32	150	50	14						
AEM90-AX1705-D32-C32-L180-Z02-H	●	32	2	32	180	50	14						

R: Derecha / Droite / Right L: Izquierda / Gauche / Left

● En Existencia / En stock / In Stock ○ Artículo sin Existencia / Indisponible en Stock / Non Stock Item



Compatible con el Inserto SMTM. / Compatible avec SMTM Plaquettes. / Compatible with SMTM Insert.

Ejemplo de Pedido / Exemple de Commande / Ordering Example

1 Piezas / pcs. / pcs. AEM90-AX1235-D16-C14-L120-Z02-H

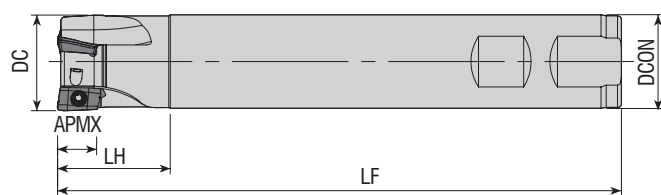
Cálculo de Corte : S 369 / Calcul de Coupe : P 369 / Cutting Calculation : 369

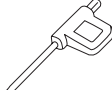

Código del Inserto Le Code de Commande Ordering Code	Stock Stock Stock	Dimension (mm) Dimension (mm) Dimension (mm)						Inserto Plaquette Insert	Recambios / Pièces de Rechange / Spare Parts				
		DC	ZEFP	DCON	LF	LH	APMX		Tornillo Vis Screw	Llave Torx Clé Torx Torx Wrench			
AEM90-AZ11-D12-W16-L90-Z01	●	12	1	16	90	30	11						
AEM90-AZ11-D16-C16-L200-Z02	●	16	2	16	200	100	11						
AEM90-AZ11-D16-W15-L170-Z02	●	16	2	15	170	50	11						
AEM90-AZ11-D16-W16-L100-Z02	●	16	2	16	100	35	11						
AEM90-AZ11-D16-W16-L150-Z02	●	16	2	16	150	50	11						
AEM90-AZ11-D17-C16-L150-Z02	●	17	2	16	150	30	11						
AEM90-AZ11-D17-C16-L180-Z02	●	17	2	16	180	50	11						
AEM90-AZ11-D17-W16-L100-Z02	●	17	2	16	100	30	11						
AEM90-AZ11-D18-W16-L120-Z02	●	18	2	16	120	18	11						
AEM90-AZ11-D20-C20-L200-Z03	●	20	3	20	200	100	11				AZGT 1135..	3008-M2.5X6	80-T08
AEM90-AZ11-D20-W19-L170-Z03	●	20	3	19	170	50	11						
AEM90-AZ11-D20-W20-L110-Z02	●	20	2	20	110	35	11						
AEM90-AZ11-D21-C20-L150-Z03	●	21	3	20	150	30	11						
AEM90-AZ11-D21-C20-L180-Z03	●	21	3	20	180	50	11						
AEM90-AZ11-D21-W20-L110-Z03	●	21	3	20	110	35	11						
AEM90-AZ11-D22-C20-L150-Z02	●	22	2	20	150	30	11						
AEM90-AZ11-D25-C24-L180-Z04	●	25	4	24	180	50	11						
AEM90-AZ11-D25-W25-L110-Z04	●	25	4	25	110	40	11						
AEM90-AZ11-D26-C25-L250-Z02	●	26	2	25	250	50	11						
AEM90-AZ11-D26-W25-L120-Z03	●	26	3	25	120	30	11						
AEM90-AZ11-D26-W25-L120-Z04	●	26	4	25	120	40	11						
AEM90-AZ11-D28-C25-L180-Z03	●	28	3	25	180	50	11						
AEM90-AZ11-D28-C25-L250-Z02	●	28	2	25	250	50	11						
AEM90-AZ11-D33-W32-L130-Z04	●	33	4	32	130	50	11						

R: Derecha / Droite / Right L: Izquierda / Gauche / Left



● En Existencia / En stock / In Stock ○ Artículo sin Existencia / Indisponible en Stock / Non Stock Item
 Compatible con el Inserto ZCC. / Compatible avec ZCC Plaquettes. / Compatible with ZCC Insert.

Ejemplo de Pedido / Exemple de Commande / Ordering Example

1 Piezas / pcs. / pcs. AEM90-AZ11-D12-W16-L90-Z01

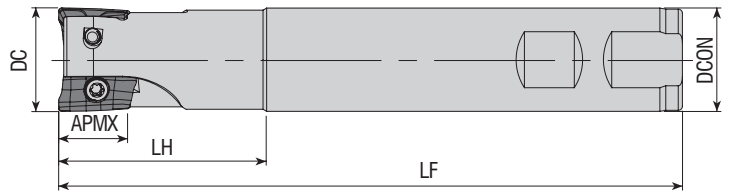
Cálculo de Corte : S 369 / Calcul de Coupe : P 369 / Cutting Calculation : 369

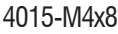

Código del Inserto Le Code de Commande Ordering Code	Stock Stock Stock	Dimension (mm) Dimension (mm) Dimension (mm)						Inserto Plaquette Insert	Recambios / Pièces de Rechange / Spare Parts		
		DC	ZEFP	DCON	LF	LH	APMX		Tornillo Vis Screw	Llave Torx Clé Torx Torx Wrench	
AEM90-BD11T3-D16-C16-L100-Z02-H	●	16	2	16	100	30	10				
AEM90-BD11T3-D16-W16-L100-Z02-H	●	16	2	16	100	30	10				
AEM90-BD11T3-D16-W16-L150-Z02	●	16	2	16	150	50	10				
AEM90-BD11T3-D16-C16-L160-Z02-H	●	16	2	16	160	50	10				
AEM90-BD11T3-D16-C15-L180-Z02	●	16	2	15	180	50	10				
AEM90-BD11T3-D17-W16-L150-Z02	●	17	2	16	150	25	10				
AEM90-BD11T3-D17-C16-L180-Z02	●	17	2	16	180	25	10				
AEM90-BD11T3-D18-W16-L100-Z02	●	18	2	16	100	25	10				
AEM90-BD11T3-D18-W16-L100-Z02-H	●	18	2	16	100	25	10				
AEM90-BD11T3-D20-W20-L81-Z03-H	●	20	3	20	81	30	10				
AEM90-BD11T3-D20-W20-L100-Z02-H	●	20	2	20	100	30	10				
AEM90-BD11T3-D20-W20-L100-Z03-H	●	20	3	20	100	30	10				
AEM90-BD11T3-D20-C20-L110-Z03-H	●	20	3	20	110	30	10				
AEM90-BD11T3-D20-W20-L150-Z02	●	20	2	20	150	50	10				
AEM90-BD11T3-D20-W20-L150-Z03	●	20	3	20	150	50	10				
AEM90-BD11T3-D20-W20-L150-Z03-H	●	20	3	20	150	50	10				
AEM90-BD11T3-D20-C20-L170-Z03-H	●	20	3	20	170	50	10				
AEM90-BD11T3-D21-W20-L150-Z03	●	21	3	20	150	25	10				
AEM90-BD11T3-D21-C20-L200-Z02	●	21	2	20	200	25	10				
AEM90-BD11T3-D22-W20-L090-Z02-H	●	22	2	20	90	25	10				
AEM90-BD11T3-D25-W25-L100-Z03-H	●	25	3	25	100	30	10				
AEM90-BD11T3-D25-C20-L120-Z03-H	●	25	3	20	120	30	10				
AEM90-BD11T3-D25-C25-L120-Z03-H	●	25	3	25	120	30	10				
AEM90-BD11T3-D25-W25-L150-Z03	●	25	3	25	150	50	10				
AEM90-BD11T3-D26-W25-L150-Z03	●	26	3	25	150	35	10				
AEM90-BD11T3-D26-C25-L250-Z02	●	26	2	25	250	35	10				
AEM90-BD11T3-D32-W32-L110-Z04-H	●	32	4	32	110	40	10				
AEM90-BD11T3-D32-C32-L130-Z04-H	●	32	4	32	130	40	10				
AEM90-BD11T3-D32-W32-L150-Z04	●	32	4	32	150	50	10				
AEM90-BD11T3-D40-W32-L110-Z04-H	●	40	4	32	110	35	10				
AEM90-BD1704-D25-W25-L100-Z02-H	●	25	2	25	100	35	15.7				80-T15
AEM90-BD1704-D25-W25-L150-Z02	●	25	2	25	150	50	15.7				
AEM90-BD1704-D25-C25-L210-Z02-H	●	25	2	25	210	100	15.7				
AEM90-BD1704-D32-W32-L110-Z03-H	●	32	3	32	110	40	15.7				
AEM90-BD1704-D32-C32-L130-Z03-H	●	32	3	32	130	40	15.7				
AEM90-BD1704-D32-W32-L130-Z03-H	●	32	3	32	130	40	15.7				
AEM90-BD1704-D32-W32-L150-Z03	●	32	3	32	150	50	15.7				
AEM90-BD1704-D40-W32-L110-Z04-H	●	40	4	32	110	40	15.7				
AEM90-BD1704-D40-W32-L150-Z04	●	40	4	32	150	40	15.7				

R: Derecha / Droite / Right L: Izquierda / Gauche / Left

● En Existencia / En stock / In Stock ○ Artículo sin Existencia / Indisponible en Stock / Non Stock Item
Compatible con el Inserto KYCR. / Compatible avec KYCR Plaquettes. / Compatible with KYCR Insert.

Ejemplo de Pedido / Exemple de Commande / Ordering Example

1 Piezas / pcs. / pcs. AEM90-BD11T3-D16-C16-L100-Z02-H

Cálculo de Corte : S 369 / Calcul de Coupe : P 369 / Cutting Calculation : 369

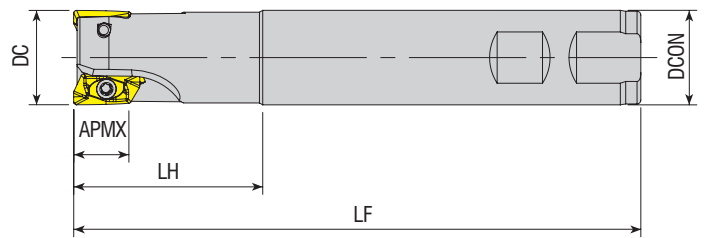

Código del Inserto Le Code de Commande Ordering Code	Stock Stock Stock	Dimension (mm) Dimension (mm) Dimension (mm)						Inserto Plaquette Insert	Recambios / Pièces de Rechange / Spare Parts		
		DC	ZEFP	DCON	LF	LH	APMX		Tornillo Vis Screw	Llave Torx Clé Torx Torx Wrench	
AEM90-ED10T3-D16-W16-L120-Z02	●	16	2	16	120	30	30	EDPT 10T3..	3008-M2.5x5	80-T08	
AEM90-ED10T3-D20-W20-L120-Z02	●	20	2	20	120	30	30		3008-M2.5x6		
AEM90-ED1404-D20-W20-L150-Z02	●	20	2	20	150	50	14.5	EDPT 1404..	3008-M3x6		
AEM90-ED1404-D25-W25-L150-Z02	●	25	2	25	150	50	14.5				
AEM90-ED1404-D30-C25-L150-Z03	●	30	3	25	150	50	14.5				

Compatible con el Inserto KNMTL. / Compatible avec KNMTL Plaquettes. / Compatible with KNMTL Insert.

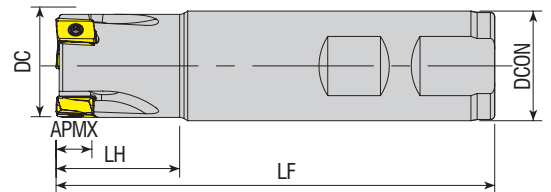

Código del Inserto Le Code de Commande Ordering Code	Stock Stock Stock	Dimension (mm) Dimension (mm) Dimension (mm)						Inserto Plaquette Insert	Recambios / Pièces de Rechange / Spare Parts		
		DC	ZEFP	DCON	LF	LH	APMX		Tornillo Vis Screw	Llave Torx Clé Torx Torx Wrench	
AEM90-LN08-D16-W16-L100-Z02-H	●	16	2	16	100	28	8	LNMT 0804..	1707-U4-48x6	80-T07	
AEM90-LN08-D16-W16-L150-Z02	●	16	2	16	150	40	8				1707-U4-48x6.5
AEM90-LN08-D20-W20-L100-Z03-H	●	20	3	20	100	28	8		1707-U4-48x8.2		
AEM90-LN08-D25-W25-L100-Z03-H	●	25	3	25	100	30	8				
AEM90-LN08-D32-W32-L110-Z05-H	●	32	5	32	110	30	8				

R: Derecha / Droite / Right L: Izquierda / Gauche / Left

● En Existencia / En stock / In Stock ○ Artículo sin existencia / Indisponible en Stock / Non Stock Item
 Compatible con el Inserto ISCR. / Compatible avec ISCR Plaquettes. / Compatible with ISCR Insert.

Ejemplo de Pedido / Exemple de Commande / Ordering Example

1 Piezas / pcs. / pcs. AEM90-ED10T3-D16-W16-L120-Z02
 Cálculo de Corte : S 369 / Calcul de Coupe : P 369 / Cutting Calculation : 369

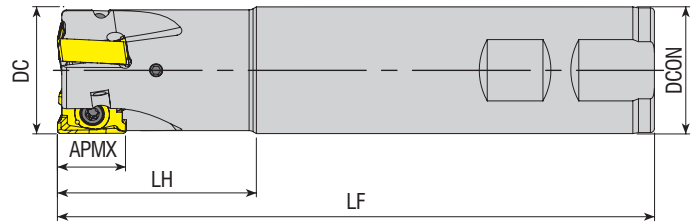

Código del Inserto Le Code de Commande Ordering Code	Stock Stock	Dimension (mm) Dimension (mm)						Inserto Plaquette Insert	Recambios / Pièces de Rechange / Spare Parts		
		DC	ZEFP	DCON	LF	LH	APMX		Tornillo Vis Screw	Llave Torx Clé Torx Torx Wrench	
AEM90-LN15T6-D25-W25-L150-Z02-H	●	25	2	25	150	50	15.5	LNGU 15T6..	4015-M4x12	80-T15	
AEM90-LN15T6-D32-W32-L150-Z03-H	●	32	3	32	150	50	15.5				
AEM90-LN15T6-D40-W32-L150-Z03-H	●	40	3	32	150	40	15.5				

Compatible con el Inserto KNMTL. / Compatible avec KNMTL Plaquettes. / Compatible with KNMTL Insert.

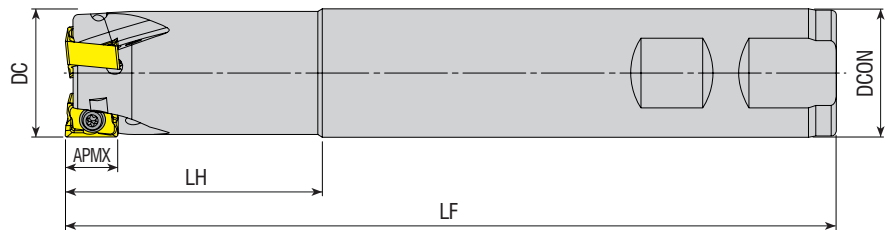

Código del Inserto Le Code de Commande Ordering Code	Stock Stock	Dimension (mm) Dimension (mm)						Inserto Plaquette Insert	Recambios / Pièces de Rechange / Spare Parts		
		DC	ZEFP	DCON	LF	LH	APMX		Tornillo Vis Screw	Llave Torx Clé Torx Torx Wrench	
AEM90-LN1006-D16-W16-L120-Z01-H	●	16	1	16	120	30	9	LN.X 1006..	4010-M3x8	80-T10	
AEM90-LN1006-D16-W16-L150-Z01	●	16	1	16	150	50	9				
AEM90-LN1006-D18-W16-L120-Z02-H	●	18	2	16	120	30	9				
AEM90-LN1006-D20-W20-L120-Z02-H	●	20	2	20	120	30	9				
AEM90-LN1006-D20-W20-L150-Z02	●	20	2	20	150	50	9				
AEM90-LN1006-D25-W25-L120-Z03-H	●	25	3	25	120	30	9				
AEM90-LN1006-D25-W25-L150-Z03	●	25	3	25	150	50	9				
AEM90-LN1006-D32-W32-L120-Z04-H	●	32	4	32	120	30	9				
AEM90-LN1006-D32-W32-L150-Z04	●	32	4	32	150	50	9				

R: Derecha / Droite / Right L: Izquierda / Gauche / Left

● En Existencia / En stock / In Stock ○ Artículo sin Existencia / Indisponible en Stock / Non Stock Item
Compatible con el Inserto KRLY. / Compatible avec KRLY Plaquettes. / Compatible with KRLY Insert.

Ejemplo de Pedido / Exemple de Commande / Ordering Example

1 Piezas / pcs. / pcs. AEM90-LN15T6-D25-W25-L150-Z02-H

Cálculo de Corte : S 369 / Calcul de Coupe : P 369 / Cutting Calculation : 369

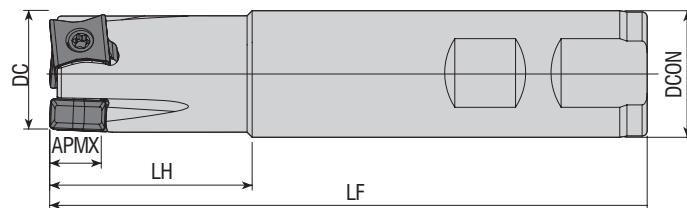

Código del Inserto Le Code de Commande Ordering Code	Stock Stock Stock	Dimension (mm) Dimension (mm) Dimension (mm)						Inserto Plaquette Insert	Recambios / Pièces de Rechange / Spare Parts		
		DC	ZEFP	DCON	LF	LH	APMX		Tornillo Vis Screw	Llave Torx Cle Torx Torx Wrench	
AEM90-LN1106-D25-W25-L150-Z03	●	25	3	25	150	40	10	LNMT 1106..			
AEM90-LN1106-D32-W32-L150-Z04	●	32	4	32	150	40	10				
AEM90-LN1106-D40-W32-L150-Z05	●	40	5	32	150	40	10				

Compatible con el Inserto XTC-GSC. / Compatible avec XTC-GSC Plaquettes. / Compatible with XTC-GSC Insert.

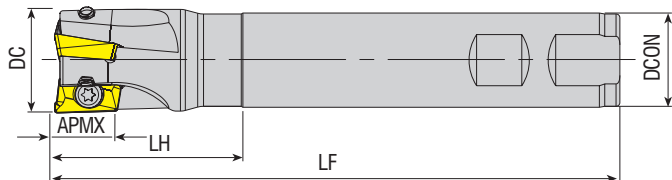

Código del Inserto Le Code de Commande Ordering Code	Stock Stock Stock	Dimension (mm) Dimension (mm) Dimension (mm)						Inserto Plaquette Insert	Recambios / Pièces de Rechange / Spare Parts		
		DC	ZEFP	DCON	LF	LH	APMX		Tornillo Vis Screw	Llave Torx Cle Torx Torx Wrench	
AEM90-R390.11-D12-W12-L100-Z01	●	12	1	12	100	25	10	R390-11T3..			
AEM90-R390.11-D16-W16-L100-Z02-H	●	16	2	16	100	30	10				
AEM90-R390.11-D16-W16-L150-Z02	●	16	2	16	150	50	10				
AEM90-R390.11-D16-W16-L150-Z02-H	●	16	2	16	150	50	10				
AEM90-R390.11-D20-W20-L090-Z02-H	●	20	2	20	90	30	10				
AEM90-R390.11-D20-W20-L100-Z03-H	●	20	3	20	100	30	10				
AEM90-R390.11-D20-W20-L150-Z03	●	20	3	20	150	50	10				
AEM90-R390.11-D20-W20-L150-Z03-H	●	20	3	20	150	50	10				
AEM90-R390.11-D20-C20-L150-Z03	●	20	3	20	150	30	10				
AEM90-R390.11-D22-W20-L090-Z02-H	●	22	2	20	90	30	10				
AEM90-R390.11-D25-C20-L150-Z03	●	25	3	20	150	40	10				
AEM90-R390.11-D25-W25-L100-Z03-H	●	25	3	25	100	30	10				
AEM90-R390.11-D25-W25-L150-Z03	●	25	3	25	150	50	10				
AEM90-R390.11-D25-W25-L150-Z03-H	●	25	3	25	150	50	10				
AEM90-R390.11-D30-W25-L150-Z04-H	●	30	4	25	150	30	10				
AEM90-R390.11-D32-C25-L200-Z03	●	32	3	25	200	40	10				
AEM90-R390.11-D32-W32-L150-Z05-H	●	32	5	32	150	50	10				
AEM90-R390.17-D25-W25-L150-Z02	●	25	2	25	150	50	15.4	R390-1704..			
AEM90-R390.17-D25-W25-L150-Z02-H	●	25	2	25	150	50	15.4				
AEM90-R390.17-D30-W25-L150-Z03	●	30	3	25	150	40	15.4				
AEM90-R390.17-D30-W25-L150-Z03-H	●	30	3	25	150	40	15.4				
AEM90-R390.17-D32-W32-L150-Z03-H	●	32	3	32	150	40	15.4				
AEM90-R390.18-D32-C32-L150-Z03	●	32	3	32	150	45	15.4				
AEM90-R390.18-D32-C32-L150-Z03	●	32	3	32	150	45	15.4	R390-1806..	4015-M4x11		

R: Derecha / Droite / Right L: Izquierda / Gauche / Left

● En Existencia / En stock / In Stock ○ Artículo sin Existencia / Indisponible en Stock / Non Stock Item
 Compatible con el Inserto SNDVK. / Compatible avec SNDVK Plaquettes. / Compatible with SNDVK Insert.

Ejemplo de Pedido / Exemple de Commande / Ordering Example

1 Piezas / pcs. / pcs. AEM90-LN1106-D25-W25-L150-Z03
 Cálculo de Corte : S 369 / Calcul de Coupe : P 369 / Cutting Calculation : 369

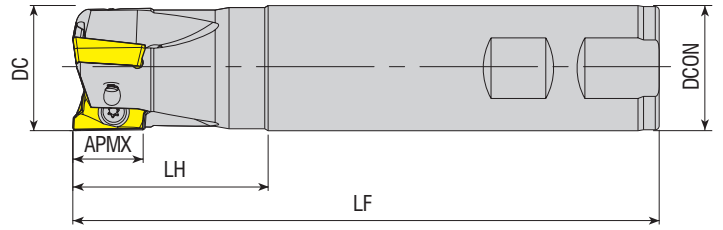

Código del Inserto Le Code de Commande Ordering Code	Stock Stock Stock	Dimension (mm) Dimension (mm) Dimension (mm)						Inserto Plaquette Insert	Recambios / Pièces de Rechange / Spare Parts	
		DC	ZEFP	DCON	LF	LH	APMX		Tornillo Vis Screw	Llave Torx Clé Torx Torx Wrench
AEM90-RT07-D10-W10-L120-Z02	●	10	2	10	120	30	7	RT 0702	3006-M2x4	80-T06
AEM90-RT07-D12-C12-L120-Z02	●	12	2	12	120	30	7			
AEM90-RT07-D12-W12-L120-Z02	●	12	2	12	120	30	7			
AEM90-RT07-D14-W12-L120-Z02	●	14	2	12	120	30	7			
AEM90-RT10-D16-C15-L160-Z02	●	16	2	15	160	30	10	RT 1003	3008-M2.5x6	80-T08
AEM90-RT10-D16-W16-L120-Z02-H	●	16	2	16	120	30	10			
AEM90-RT10-D16-W16-L150-Z02	●	16	2	16	150	30	10			
AEM90-RT10-D16-C16-L200-Z02	●	16	2	16	200	100	10			
AEM90-RT10-D17-W16-L160-Z02	●	17	2	16	160	30	10			
AEM90-RT10-D17-C16-L200-Z02	●	17	2	16	200	30	10			
AEM90-RT10-D18-W16-L120-Z02-H	●	18	2	16	120	30	10			
AEM90-RT10-D20-C19-L200-Z03	●	20	3	19	200	30	10			
AEM90-RT10-D20-C20-L110-Z03	●	20	3	20	110	30	10			
AEM90-RT10-D20-W20-L120-Z03-H	●	20	3	20	120	30	10			
AEM90-RT10-D20-W20-L150-Z03	●	20	3	20	150	50	10			
AEM90-RT10-D20-C20-L200-Z03	●	20	3	20	200	100	10			
AEM90-RT10-D21-W20-L200-Z03	●	21	3	20	200	30	10			
AEM90-RT10-D22-W20-L120-Z03-H	●	22	3	20	120	30	10			
AEM90-RT10-D22-C20-L150-Z03	●	22	3	20	150	30	10			
AEM90-RT10-D22-C20-L200-Z03	●	22	3	20	200	30	10			
AEM90-RT10-D25-W25-L120-Z04-H	●	25	4	25	120	40	10			
AEM90-RT10-D25-W25-L150-Z04	●	25	4	25	150	50	10			
AEM90-RT10-D25-C25-L200-Z04	●	25	4	25	200	100	10			
AEM90-RT10-D26-C25-L250-Z04	●	26	4	25	250	32	10			
AEM90-RT10-D32-W32-L120-Z05-H	●	32	5	32	120	50	10			
AEM90-RT10-D32-W32-L150-Z05	●	32	5	32	150	50	10			
AEM90-RT10-D32-C32-L200-Z05	●	32	5	32	200	100	10			
AEM90-RT10-D33-C32-L250-Z04	●	33	4	32	250	32	10			
AEM90-RT13-D32-C32-L250-Z04	●	32	4	32	250	50	13	RT 1304	3008-M3x8	
AEM90-RT16-D25-W25-L120-Z02-H	●	25	2	25	120	40	16	RT 1606	4015-M4x9	80-T15
AEM90-RT16-D25-W25-L150-Z02	●	25	2	25	150	50	16			
AEM90-RT16-D25-C25-L200-Z02	●	25	2	25	200	100	16			
AEM90-RT16-D32-W32-L120-Z03-H	●	32	3	32	120	50	16			
AEM90-RT16-D32-W32-L150-Z03	●	32	3	32	150	50	16			
AEM90-RT16-D32-C32-L200-Z03	●	32	3	32	200	100	16			
AEM90-RT16-D32-C32-L250-Z03	●	32	3	32	250	100	16			
AEM90-RT16-D32-C32-L270-Z03	●	32	3	32	270	100	16			
AEM90-RT16-D40-W32-L120-Z04-H	●	40	4	32	120	50	16			
AEM90-RT16-D40-W32-L150-Z04	●	40	4	32	150	50	16			
AEM90-RT16-D40-C32-L200-Z04	●	40	4	32	200	100	16			

R: Derecha / Droite / Right L: Izquierda / Gauche / Left
● En Existencia / En stock / In Stock ○ Artículo sin Existencia / Indisponible en Stock / Non Stock Item
Compatible con el Inserto SFTY. / Compatible avec SFTY Plaquettes. / Compatible with SFTY Insert.

Ejemplo de Pedido / Exemple de Commande / Ordering Example
1 Piezas / pcs. / pcs. AEM90-RT07-D10-W10-L120-Z02
Cálculo de Corte : S 369 / Calcul de Coupe : P 369 / Cutting Calculation : 369

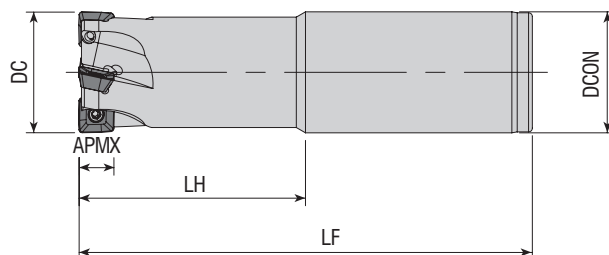

Código del Inserto Le Code de Commande Ordering Code	Stock Stock Stock	Dimension (mm) Dimension (mm) Dimension (mm)						Inserto Plaquette Insert	Recambios / Pièces de Rechange / Spare Parts		
		DC	ZEFP	DCON	LF	LH	APMX		Tornillo Vis Screw	Llave Torx Clé Torx Torx Wrench	
AEM90-SE09-D25-C25-L120-Z03-H	●	25	3	25	120	60	6.7	SEET 09T3..		80-T08	
AEM90-SE09-D25-C25-L150-Z02	●	25	2	25	150	50	6.7				
AEM90-SE09-D32-C32-L120-Z04-H	●	32	4	32	120	60	6.7				
AEM90-SE09-D32-C32-L150-Z03	●	32	3	32	150	50	6.7				

Compatible con el Inserto ZCC. / Compatible avec ZCC Plaquettes. / Compatible with ZCC Insert.

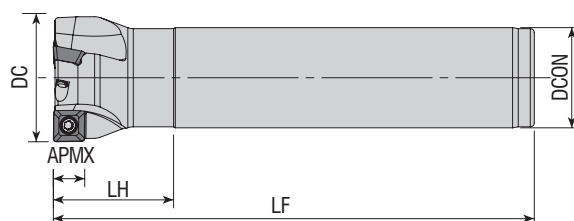

Código del Inserto Le Code de Commande Ordering Code	Stock Stock Stock	Dimension (mm) Dimension (mm) Dimension (mm)						Inserto Plaquette Insert	Recambios / Pièces de Rechange / Spare Parts		
		DC	ZEFP	DCON	LF	LH	APMX		Tornillo Vis Screw	Llave Torx Clé Torx Torx Wrench	
AEM90-S00803-D20-C16-L110-Z02-H	●	20	2	16	110	25	7	SOMT 0803..		80-T08	
AEM90-S00803-D25-C20-L110-Z02-H	●	25	2	20	110	25	7				
AEM90-S00803-D32-C25-L120-Z03-H	●	32	3	25	120	30	7				

R: Derecha / Droite / Right L: Izquierda / Gauche / Left

● En Existencia / En stock / In Stock ○ Artículo sin Existencia / Indisponible en Stock / Non Stock Item
Compatible con el Inserto SMTM. / Compatible avec SMTM Plaquettes. / Compatible with SMTM Insert.

Ejemplo de Pedido / Exemple de Commande / Ordering Example

1 Piezas / pcs. / pcs. AEM90-SE09-D25-C25-L120-Z03-H
Cálculo de Corte : S 369 / Calcul de Coupe : P 369 / Cutting Calculation : 369

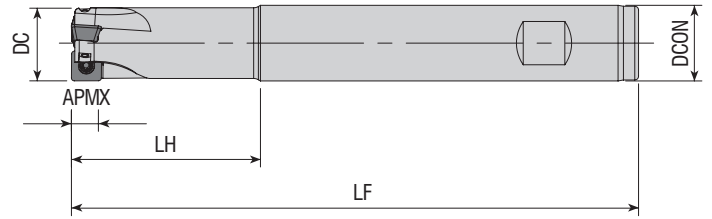

Código del Inserto Le Code de Commande Ordering Code	Stock Stock Stock	Dimension (mm) Dimension (mm) Dimension (mm)						Inserto Plaquette Insert	Recambios / Pièces de Rechange / Spare Parts		
		DC	ZEFP	DCON	LF	LH	APMX		Tornillo Vis Screw	Llave Torx Clé Torx Torx Wrench	
AEM90-SPGT0602-D16-W16-L150-Z02	●	16	2	16	150	50	5.5				
AEM90-SPGT07T3-D20-W20-L150-Z03	●	20	3	20	150	50	7	SPGT 07T308	3008-M2.5x6	80-T08	
AEM90-SPGT07T3-D25-W25-L150-Z03	●	25	3	25	150	50	7				
AEM90-SPGT0904-D30-W32-L150-Z03	●	30	3	32	150	50	9	SPGT 090408	4015-M3.5x9	80-T15	

Compatible con el Inserto ZCC. / Compatible avec ZCC Plaquettes. / Compatible with ZCC Insert.

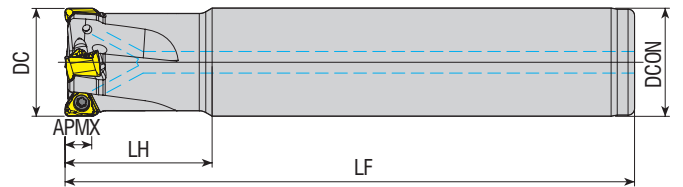

Código del Inserto Le Code de Commande Ordering Code	Stock Stock Stock	Dimension (mm) Dimension (mm) Dimension (mm)						Inserto Plaquette Insert	Recambios / Pièces de Rechange / Spare Parts		
		DC	ZEFP	DCON	LF	LH	APMX		Tornillo Vis Screw	Llave Torx Clé Torx Torx Wrench	
AEM90-TNG10-D20-C20-L125-Z02-H	●	20	2	20	125	29	5				
AEM90-TNG10-D20-C20-L125-Z03-H	●	20	3	20	125	29	5				
AEM90-TNG10-D20-C20-L150-Z03-H	○	20	3	20	150	50	5				
AEM90-TNG10-D21-C20-L200-Z03-H	●	21	3	20	200	30	5				
AEM90-TNG10-D25-C25-L150-Z03-H	●	25	3	25	150	34	5				
AEM90-TNG10-D25-C25-L150-Z04-H	●	25	4	25	150	34	5				
AEM90-TNG10-D25-C25-L170-Z04-H	○	25	4	25	170	50	5				
AEM90-TNG10-D26-C25-L250-Z04-H	●	26	4	25	250	35	5				
AEM90-TNG10-D32-C32-L170-Z04-H	●	32	4	32	170	37	5				
AEM90-TNG10-D32-C32-L170-Z05-H	○	32	5	32	170	37	5				
AEM90-TNG10-D33-C32-L250-Z05-H	●	33	5	32	250	35	5				

R: Derecha / Droite / Right L: Izquierda / Gauche / Left

● En Existencia / En stock / In Stock ○ Artículo sin Existencia / Indisponible en Stock / Non Stock Item
Compatible con el Inserto PRMT. / Compatible avec PRMT Plaquettes. / Compatible with PRMT Insert.

Ejemplo de Pedido / Exemple de Commande / Ordering Example

1 Piezas / pcs. / pcs. AEM90-SPGT0602-D16-W16-L150-Z02

Cálculo de Corte : S 369 / Calcul de Coupe : P 369 / Cutting Calculation : 369



KAPR=90°

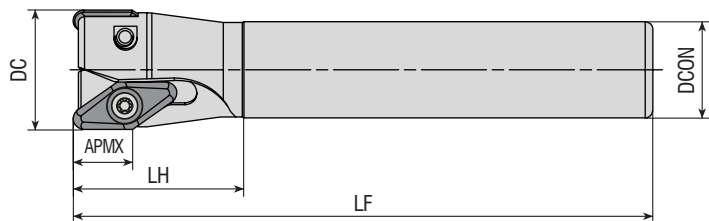

Código del Inserto Le Code de Commande Ordering Code	Stock Stock Stock	Dimension (mm) Dimension (mm) Dimension (mm)						Inserto Plaquette Insert	Recambios / Pièces de Rechange / Spare Parts		
		DC	ZEP	DCON	LF	LH	APMX		Tornillo Vis Screw	Llave Torx Clé Torx Torx Wrench	
AEM90-VC2205-D32-C25-L150-Z02-H	●	32	2	25	150	50	15	VCKT 2205..			
AEM90-VC2205-D40-C32-L150-Z03-H	●	40	3	32	150	50	15				

Compatible con el Inserto ISO. / Compatible avec ISO Plaquettes. / Compatible with ISO Insert.



KAPR=90°

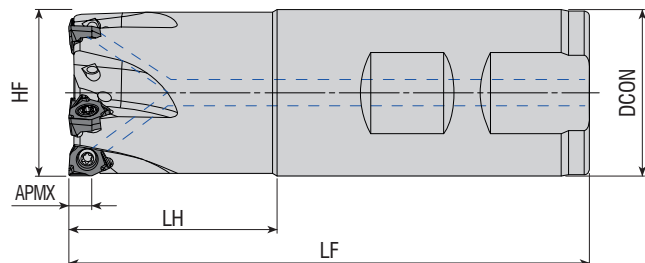

Código del Inserto Le Code de Commande Ordering Code	Stock Stock Stock	Dimension (mm) Dimension (mm) Dimension (mm)						Inserto Plaquette Insert	Recambios / Pièces de Rechange / Spare Parts		
		DC	ZEP	DCON	LF	LH	APMX		Tornillo Vis Screw	Llave Torx Clé Torx Torx Wrench	
AEM90-WNG04-D20-W20-L81-Z03-H	●	20	3	20	81	31	4	WNGU 0403..			
AEM90-WNG04-D20-C20-L170-Z03-H	●	20	3	20	170	50	4				
AEM90-WNG04-D25-W25-L88-Z03-H	●	25	3	25	88	32	4				
AEM90-WNG04-D25-W25-L88-Z04-H	●	25	4	25	88	32	4				
AEM90-WNG04-D25-C25-L170-Z03-H	●	25	3	25	170	50	4				
AEM90-WNG04-D32-W25-L100-Z05-H	●	32	5	25	100	35	4				
AEM90-WNG04-D32-W32-L100-Z05-H	●	32	5	32	100	40	4				
AEM90-WNG04-D32-C25-L170-Z04-H	●	32	4	25	170	35	4				
AEM90-WNG04-D32-C32-L170-Z04-H	●	32	4	32	170	50	4				
AEM90-WNG08-D40-W32-L100-Z03-H	●	40	3	32	100	35	7.5	WNGU 0806..			
AEM90-WNG08-D40-C32-L170-Z03-H	●	40	3	32	170	35	7.5				

R: Derecha / Droite / Right L: Izquierda / Gauche / Left

● En Existencia / En stock / In Stock ○ Artículo sin Existencia / Indisponible en Stock / Non Stock Item
 Compatible con el Inserto XTC-GSC. / Compatible avec XTC-GSC Plaquettes. / Compatible with XTC-GSC Insert.

Ejemplo de Pedido / Exemple de Commande / Ordering Example

1 Piezas / pcs. / pcs. AEM90-VC2205-D32-C25-L150-Z02-H
 Cálculo de Corte : S 369 / Calcul de Coupe : P 369 / Cutting Calculation : 369



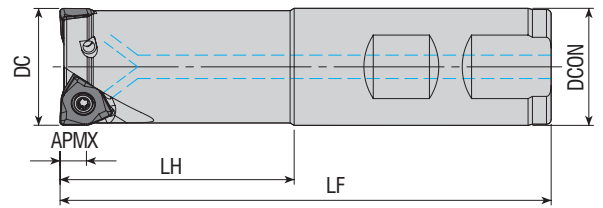

Código del Inserto Le Code de Commande Ordering Code	Stock Stock	Dimension (mm) Dimension (mm)						Inserto Plaquette Insert	Recambios / Pièces de Rechange / Spare Parts		
		DC	ZEFP	DCON	LF	LH	APMX		Tornillo Vis Screw	Llave Torx Clé Torx Torx Wrench	
AEM90L-WN0604Z-D25-C25-L200-Z02-H	●	25	2	25	200	100	5.7	WNHU 0604..	3008-M3x8	80-T08	
AEM90-WN0604Z-D25-W25-L150-Z02-H	●	25	2	25	150	50	5.7				
AEM90-WN0604Z-D32-W32-L150-Z03-H	●	32	3	32	150	50	5.7				
AEM90-WN0604Z-D40-W32-L150-Z04-H	●	40	4	32	150	35	5.7				

Compatible con el Inserto ZCC. / Compatible avec ZCC Plaquettes. / Compatible with ZCC Insert.

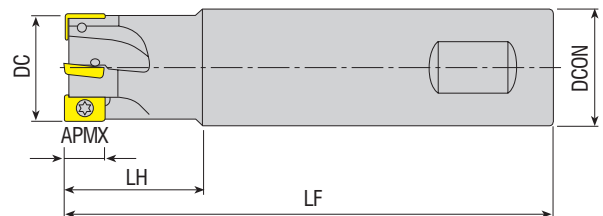

Código del Inserto Le Code de Commande Ordering Code	Stock Stock	Dimension (mm) Dimension (mm)						Inserto Plaquette Insert	Recambios / Pièces de Rechange / Spare Parts		
		DC	ZEFP	DCON	LF	LH	APMX		Tornillo Vis Screw	Llave Torx Clé Torx Torx Wrench	
AEM90-XD11T3-D16-W16-L150-Z02	●	16	2	16	150	30	10	XD.T 11T3..	3008-M2.5x5	80-T08	
AEM90-XD11T3-D17-C16-L150-Z02	●	17	2	16	150	30	10				
AEM90-XD11T3-D20-W20-L150-Z03	●	20	3	20	150	50	10				
AEM90-XD11T3-D21-C20-L080-Z03-H	●	21	3	20	80	25	10				
AEM90-XD11T3-D21-C20-L150-Z03	●	21	3	20	150	30	10				
AEM90-XD11T3-D25-W25-L150-Z04	●	25	4	25	150	50	10				
AEM90-XD11T3-D30-W25-L120-Z04	●	30	4	25	120	30	10				
AEM90-XD11T3-D32-W32-L150-Z04	●	32	4	32	150	50	10				
AEM90-XD11T3-D33-C20-L080-Z04-H	●	33	4	20	80	30	10				

R: Derecha / Droite / Right L: Izquierda / Gauche / Left

● En Existencia / En stock / In Stock ○ Artículo sin Existencia / Indisponible en Stock / Non Stock Item
Compatible con el Inserto CRTZT. / Compatible avec CRTZT Plaquettes. / Compatible with CRTZT Insert.

Ejemplo de Pedido / Exemple de Commande / Ordering Example

1 Piezas / pcs. / pcs. AEM90L-WN0604Z-D25-C25-L200-Z02-H

Cálculo de Corte : S 369 / Calcul de Coupe : P 369 / Cutting Calculation : 369

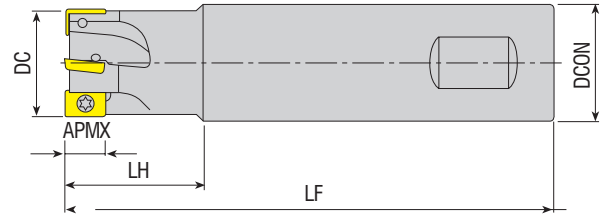

Código del Inserto Le Code de Commande Ordering Code	Stock Stock Stock	Dimension (mm) Dimension (mm) Dimension (mm)						Inserto Plaquette Insert	Recambios / Pièces de Rechange / Spare Parts			
		DC	ZEFP	DCON	LF	LH	APMX		Tornillo Vis Screw	Llave Torx Clé Torx Torx Wrench		
AEM90-XC13-D20-W20-L150-Z02	●	20	2	20	150	60	13					
AEM90-XC13-D25-W25-L150-Z03	●	25	3	25	150	60	13				3008-M3x8	80-T08
AEM90-XC13-D32-W32-L150-Z04	●	32	4	32	150	60	13					

Compatible con el Inserto SC. / Compatible avec SC Plaquettes. / Compatible with SC Insert.

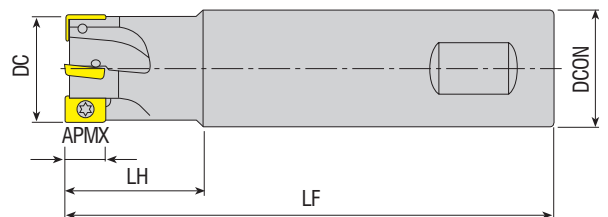

Código del Inserto Le Code de Commande Ordering Code	Stock Stock Stock	Dimension (mm) Dimension (mm) Dimension (mm)						Inserto Plaquette Insert	Recambios / Pièces de Rechange / Spare Parts			
		DC	ZEFP	DCON	LF	LH	APMX		Tornillo Vis Screw	Llave Torx Clé Torx Torx Wrench		
AEM90-X006-D10-C12-L120-Z02	●	10	2	12	120	50	5					
AEM90-X006-D12-C12-L120-Z02	●	12	2	12	120	25	5				3006-M1.8x4	80-T06
AEM90-X009-D16-W16-L150-Z02	●	16	2	16	150	50	8					
AEM90-X009-D20-W20-L150-Z03	●	20	3	20	150	50	8	3008-M2.5x5	80-T08			
AEM90-X012-D20-W20-L150-Z02	●	20	2	20	150	50	11					
AEM90-X012-D20-C20-L200-Z02	●	20	2	20	200	100	11					
AEM90-X012-D22-W20-L150-Z02	●	22	2	20	150	30	11					
AEM90-X012-D25-W25-L150-Z03	●	25	3	25	150	50	11					
AEM90-X012-D25-C25-L200-Z03	●	25	3	25	200	100	11					
AEM90-X012-D32-C25-L150-Z04	●	32	4	25	150	40	11					
AEM90-X012-D32-W32-L150-Z04	●	32	4	32	150	50	11					
AEM90-X012-D32-C32-L250-Z04	●	32	4	32	250	100	11					

R: Derecha / Droite / Right L: Izquierda / Gauche / Left

● En Existencia / En stock / In Stock ○ Artículo sin Existencia / Indisponible en Stock / Non Stock Item
 Compatible con el Inserto SC. / Compatible avec SC Plaquettes. / Compatible with SC Insert.

Ejemplo de Pedido / Exemple de Commande / Ordering Example

1 Piezas / pcs. / pcs. AEM90-XC13-D20-W20-L150-Z02

Cálculo de Corte : S 369 / Calcul de Coupe : P 369 / Cutting Calculation : 369

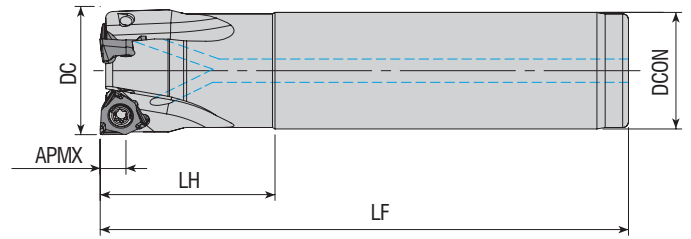

Código del Inserto Le Code de Commande Ordering Code	Stock Stock Stock	Dimension (mm) Dimension (mm) Dimension (mm)						Inserto Plaquette Insert	Recambios / Pièces de Rechange / Spare Parts				
		DC	ZEFP	DCON	LF	LH	APMX		Tornillo Vis Screw	Llave Torx Clé Torx Torx Wrench			
AEM90-XN0403-D16-C16-L100-Z01-H	●	16	1	16	100	30	4						
AEM90-XN0403-D22-C20-L110-Z03-H	●	22	3	20	110	30	4				XNEX 0403..	3008-M2.5x6	80-T08
AEM90-XN0806-D32-C32-L110-Z02-H	●	32	2	32	110	40	7.5				XNEX 0806..	4015-M4x11	80-T15

Compatible con el Inserto SC. / Compatible avec SC Plaquettes. / Compatible with SC Insert.

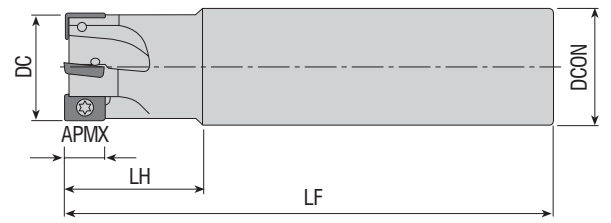

Código del Inserto Le Code de Commande Ordering Code	Stock Stock Stock	Dimension (mm) Dimension (mm) Dimension (mm)						Inserto Plaquette Insert	Recambios / Pièces de Rechange / Spare Parts		
		DC	ZEFP	DCON	LF	LH	APMX		Tornillo Vis Screw	Llave Torx Clé Torx Torx Wrench	
AEM90-ZC1003-D16-C14-L150-Z02	●	16	2	14	150	25	9				
AEM90-ZC1003-D16-C14-L200-Z02	●	16	2	14	200	25	9				
AEM90-ZC1003-D16-C15-L150-Z02	●	16	2	15	150	25	9				
AEM90-ZC1003-D16-C16-L150-Z02	●	16	2	16	150	25	9				
AEM90-ZC1003-D16-C16-L200-Z02	●	16	2	16	200	50	9				
AEM90-ZC1003-D17-C16-L150-Z02	●	17	2	16	150	25	9				
AEM90-ZC1003-D17-C16-L200-Z02	●	17	2	16	200	25	9				
AEM90-ZC1003-D20-C18-L150-Z03	●	20	3	18	150	25	9				
AEM90-ZC1003-D20-C18-L200-Z02	●	20	2	18	200	25	9				
AEM90-ZC1003-D20-C20-L150-Z03	●	20	3	20	150	40	9				
AEM90-ZC1003-D20-C18-L200-Z03	●	20	3	18	200	25	9				
AEM90-ZC1003-D21-C20-L150-Z02	●	21	2	20	150	30	9				
AEM90-ZC1003-D21-C20-L150-Z03	●	21	3	20	150	30	9				
AEM90-ZC1003-D21-C20-L200-Z03	●	21	3	20	200	30	9				
AEM90-ZC1003-D25-C20-L150-Z03	●	25	3	20	150	30	9				
AEM90-ZC1003-D25-C20-L200-Z03	●	25	3	20	200	30	9				
AEM90-ZC1003-D25-C25-L150-Z03	●	25	3	25	150	40	9				
AEM90-ZC1003-D26-C25-L170-Z03	●	26	3	25	170	25	9				
AEM90-ZC1003-D26-C25-L200-Z03	●	26	3	25	200	25	9				
AEM90-ZC1003-D32-C25-L180-Z04	●	32	4	25	180	30	9				
AEM90-ZC1003-D33-C32-L200-Z04	●	33	4	32	200	25	9				

R: Derecha / Droite / Right L: Izquierda / Gauche / Left

● En Existencia / En stock / In Stock ○ Artículo sin Existencia / Indisponible en Stock / Non Stock Item
Compatible con el Inserto DJT. / Compatible avec DJT Plaquettes. / Compatible with DJT Insert.

Ejemplo de Pedido / Exemple de Commande / Ordering Example

1 Piezas / pcs. / pcs. AEM90-XN0403-D16-C16-L100-Z01-H

Cálculo de Corte : S 369 / Calcul de Coupe : P 369 / Cutting Calculation : 369

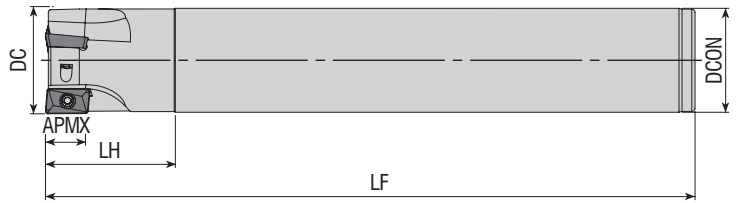

Código del Inserto Le Code de Commande Ordering Code	Stock Stock Stock	Dimension (mm) Dimension (mm) Dimension (mm)						Inserto Plaquette Insert	Recambios / Pièces de Rechange / Spare Parts		
		DC	ZEFP	DCON	LF	LH	APMX		Tornillo Vis Screw	Llave Torx Clé Torx Torx Wrench	
AEM90-ZP13T3-D26-C25-L200-Z02	●	26	2	25	200	35	13				
AEM90-ZP13T3-D26-C25-L200-Z03	●	26	3	25	200	35	13				
AEM90-ZP13T3-D26-C25-L250-Z02	●	26	2	25	250	35	13				
AEM90-ZP13T3-D33-C32-L200-Z03	●	33	3	32	200	40	13				
AEM90-ZP13T3-D33-C32-L250-Z03	●	33	3	32	250	40	13				
AEM90-ZP13T3-D33-C32-L250-Z03	●	33	3	32	250	40	13				

Compatible con el Inserto DJT. / Compatible avec DJT Plaquettes. / Compatible with DJT Insert.

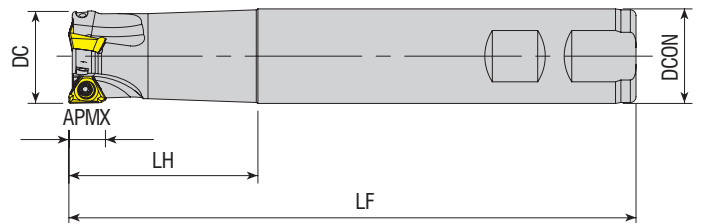

Código del Inserto Le Code de Commande Ordering Code	Stock Stock Stock	Dimension (mm) Dimension (mm) Dimension (mm)						Inserto Plaquette Insert	Recambios / Pièces de Rechange / Spare Parts		
		DC	ZEFP	DCON	LF	LH	APMX		Tornillo Vis Screw	Llave Torx Clé Torx Torx Wrench	
AEM90-3P0603-D16-W16-L120-Z03-H	●	16	3	16	120	25	4.7				
AEM90-3P0603-D20-W20-L150-Z03-H	●	20	3	20	150	25	4.7				
AEM90-3P0603-D25-W25-L150-Z05-H	●	25	5	25	150	25	4.7				
AEM90-3P1004-D20-W20-L150-Z02	●	20	2	20	150	40	7				
AEM90-3P1004-D21-C20-L200-Z02	●	21	2	20	200	30	7				
AEM90-3P1004-D25-W25-L150-Z03	●	25	3	25	150	40	7				
AEM90-3P1505-D32-W32-L150-Z03	●	32	3	32	150	50	11				
AEM90-3P1505-D38-W32-L150-Z03	●	38	3	32	150	35	11				
AEM90-3P1505-D40-W32-L150-Z04	●	40	4	32	150	35	11				

R: Derecha / Droite / Right L: Izquierda / Gauche / Left

● En Existencia / En stock / In Stock ○ Artículo sin Existencia / Indisponible en Stock / Non Stock Item

Compatible con el Inserto TGTC. / Compatible avec TGTC Plaquettes. / Compatible with TGTC Insert.

Ejemplo de Pedido / Exemple de Commande / Ordering Example

1 Piezas / pcs. / pcs. AEM90-ZP13T3-D26-C25-L200-Z02

Cálculo de Corte : S 369 / Calcul de Coupe : P 369 / Cutting Calculation : 369

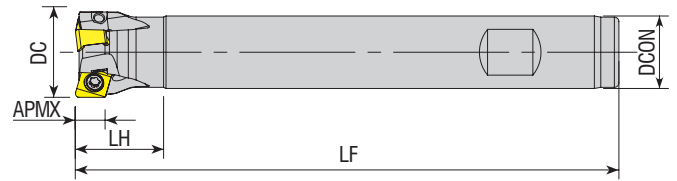

Código del Inserto Le Code de Commande Ordering Code	Stock Stock Stock	Dimension (mm) Dimension (mm) Dimension (mm)						Inserto Plaquette Insert	Recambios / Pièces de Rechange / Spare Parts		
		DC	ZEFP	DCON	LF	LH	APMX		Tornillo Vis Screw	Llave Torx Clé Torx Torx Wrench	
AEM90-4N06-D16-W16-L120-Z02-H	●	16	2	16	120	25	6	4NKT 0603..	1108-M3x6.8	80-T08	
AEM90-4N06-D16-W16-L160-Z02	●	16	2	16	160	25	6				
AEM90-4N06-D20-W16-L120-Z03-H	●	20	3	16	120	20	6				
AEM90-4N06-D20-W16-L160-Z03	●	20	3	16	160	20	6				

Compatible con el Inserto TGTC. / Compatible avec TGTC Plaquettes. / Compatible with TGTC Insert.

S-SISTEMA FRESAS DE CARA Y COPIA
 FRAISAGE EN BOUT SYSTEM S FACIALES ET COPIES
 S-SYSTEM FACE and COPY END MILLS

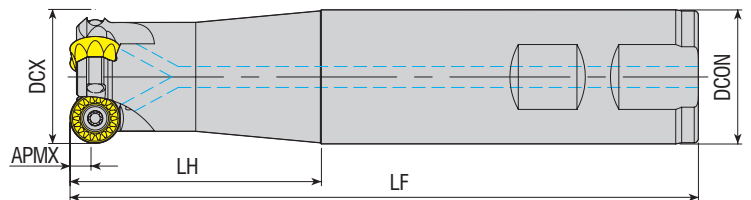

Código del Inserto Le Code de Commande Ordering Code	Stock Stock Stock	Dimension (mm) Dimension (mm) Dimension (mm)						Inserto Plaquette Insert	Recambios / Pièces de Rechange / Spare Parts				
		DCX	ZEFP	DCON	LF	LH	APMX		Tornillo Vis Screw	Abrazadera de Cuñas Mode de Fixation Wedge Clamp	Tornillo de Sujeción Vis de Fixation Wedge Screw	Llave Torx Clé Torx Torx Wrench	
AEMR-RP08T2M-D20-W20-L150-Z02-H	●	20	2	20	150	60	4	RPMT 08T2..	3008-M2.5x6	-	-	80-T08	
AEMR-RP08T2M-D25-W25-L200-Z03-H	●	25	3	25	200	100	4	RPMT 10T3..	4015-M3.5x9	-	-	80-T15	
AEMR-RP10T3M-D25-W25-L200-Z02-H	●	25	2	25	200	100	5	RPMT 1204..	4015-M4x9	-	-	80-T20	
AEMR-RP10T3M-D32-W32-L200-Z03-H	●	32	3	32	200	100	5	RPMT 1606..	1020-M5x11	-	-	80-T20	
AEMR-RP1204M-D32-W32-L150-Z03-H	●	32	3	32	150	60	6						
AEMR-RP1204M-D32-W32-L200-Z03-H	●	32	3	32	200	100	6						
AEMR-RP1606M-D40-W32-L150-Z02-H	●	40	2	16	150	35	8						
AEMR-RP1606M-D40-W32-L200-Z02-H	●	40	2	16	200	35	8						

R: Derecha / Droite / Right L: Izquierda / Gauche / Left

● En Existencia / En stock / In Stock ○ Artículo sin Existencia / Indisponible en Stock / Non Stock Item

Compatible con el Inserto MTSBH. / Compatible avec MTSBH Plaquettes. / Compatible with MTSBH Insert.

Ejemplo de Pedido / Exemple de Commande / Ordering Example

1 Piezas / pcs. / pcs. AEM90-4N06-D16-W16-L120-Z02-H

Cálculo de Corte : S 369 / Calcul de Coupe : P 369 / Cutting Calculation : 369

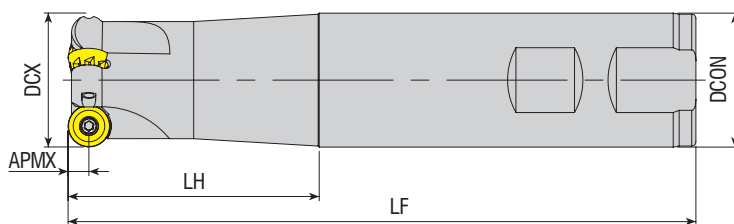

Código del Inserto Le Code de Commande Ordering Code	Stock Stock Stock	Dimension (mm) Dimension (mm) Dimension (mm)						Inserto Plaquette Insert	Recambios / Pièces de Rechange / Spare Parts			
		DCX	ZEP	DCON	LF	LH	APMX		Tornillo Vis Screw	Abrazadera de Cuñas Mode de Fixation Wedge Clamp	Tornillo de Sujeción Vis de Fixation Wedge Screw	Llave Torx Clé Torx Torx Wrench
AEMR-RP10T3-D25-W25-L125-Z02	●	25	2	25	125	60	5	RPNX 10T3..	4010-M3x8	-	-	80-T10
AEMR-RP10T3-D25-W25-L150-Z02	●	25	2	25	150	60	5					
AEMR-RP10T3-D32-W32-L150-Z03	●	32	3	32	150	60	5					

Compatible con el Inserto CRTZT. / Compatible avec CRTZT Plaquettes. / Compatible with CRTZT Insert.

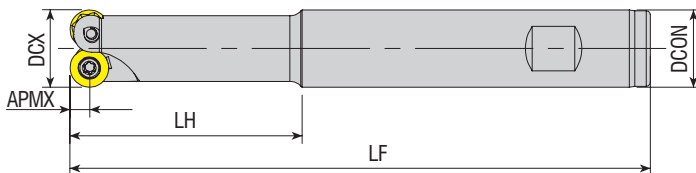

Código del Inserto Le Code de Commande Ordering Code	Stock Stock Stock	Dimension (mm) Dimension (mm) Dimension (mm)						Inserto Plaquette Insert	Tornillo Vis Screw	Llave Torx Clé Torx Torx Wrench
		DCX	ZEP	DCON	LF	LH	APMX			
AEMR-RY08-D16-W16-L150-Z02	●	16	2	16	150	55	4	RYMX 0803..	4010-M3x6	80-T10
AEMR-RY10-D20-W20-L150-Z02	●	20	2	20	150	60	5			
AEMR-RY10-D20-C20-L200-Z02	●	20	2	20	200	100	5			
AEMR-RY10-D21-W20-L200-Z02-H	●	21	2	20	200	30	5	RYMX 1004..	4015-M3.5x8	80-T15
AEMR-RY10-D25-W25-L150-Z02	●	25	2	25	150	60	5			
AEMR-RY10-D26-W25-L200-Z02-H	●	26	2	25	200	60	5			
AEMR-RY10-D32-W32-L160-Z04-H	●	32	4	32	160	60	5			
AEMR-RY12-D32-C25-L160-Z03	●	32	3	25	160	30	6	RYMX 1205..	4015-M4x11	

R: Derecha / Droite / Right L: Izquierda / Gauche / Left

● En Existencia / En stock / In Stock ○ Artículo sin Existencia / Indisponible en Stock / Non Stock Item
 Compatible con el Inserto TGTC. / Compatible avec TGTC Plaquettes. / Compatible with TGTC Insert.

Ejemplo de Pedido / Exemple de Commande / Ordering Example

1 Piezas / pcs. / pcs. AEMR-RP10T3-D25-W25-L125-Z02
 Cálculo de Corte : S 369 / Calcul de Coupe : P 369 / Cutting Calculation : 369

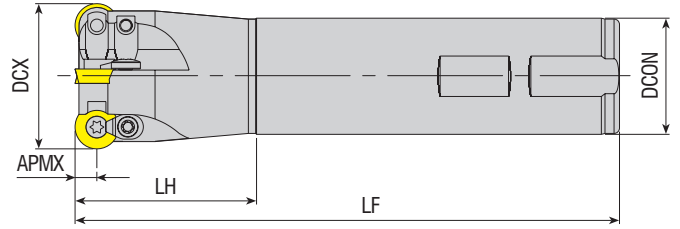

Código del Inserto Le Code de Commande Ordering Code	Stock Stock Stock	Dimension (mm) Dimension (mm) Dimension (mm)						Inserto Plaquette Insert	Recambios / Pièces de Rechange / Spare Parts				
		DCX	ZEFP	DCON	LF	LH	APMX		Tornillo Vis Screw	Abrazadera de Cuiñas Mode de Fixation Wedge Clamp	Tornillo de Sujeción Vis de Fixation Wedge Screw	Llave Torx Cle Torx Torx Wrench	
AEMR-RD0501-D08-W10-L100-Z01-H	●	8	1	10	100	20	2.5	RD.. 0501	3006-M2x3.6				80-T06
AEMR-RD0501-D10-W12-L100-Z02-H	●	10	2	12	100	20	2.5		3006-M2x4				
AEMR-RD0501-D12-W12-L120-Z02-H	●	12	2	12	120	20	2.5	RD.. 0803	3008-M3x6	-	-	80-T08	
AEMR-RD0803-D16-W16-L150-Z02	●	16	2	16	150	60	4						
AEMR-RD0803-D16-C20-L200-Z02	●	16	2	20	200	60	4	RD.. 08T2	3008-M2.5x6				
AEMR-RD0803-D20-W20-L150-Z03	●	20	3	20	150	60	4						
AEMR-RD08T2-D16-W16-L150-Z02	●	16	2	16	150	60	4	RD.. 1003					
AEMR-RD08T2-D20-W20-L150-Z02	●	20	2	20	150	60	4						
AEMRC-RD1003-D20-W20-L150-Z02	●	20	2	20	150	60	5	RD.. 10T3	4015-M3.5x9	ACK-15	4015-M3.5x11	80-T15	
AEMRC-RD1003-D20-C20-L160-Z02	●	20	2	20	160	70	5						
AEMRC-RD1003-D20-C20-L250-Z02	●	20	2	20	250	150	5						
AEMRC-RD1003-D21-C20-L160-Z02	●	21	2	20	160	70	5						
AEMRC-RD1003-D25-W25-L150-Z02	●	25	2	25	150	60	5						
AEMRC-RD1003-D25-C25-L160-Z02	●	25	2	25	160	70	5						
AEMRC-RD1003-D25-W25-L200-Z02	●	25	2	25	200	100	5						
AEMRC-RD1003-D25-C25-L200-Z02	●	25	2	25	200	100	5						
AEMRC-RD1003-D25-C25-L250-Z02	●	25	2	25	250	150	5						
AEMRC-RD1003-D26-C25-L160-Z02	●	26	2	25	160	70	5						
AEMRC-RD1003-D32-W32-L150-Z03	●	32	3	32	150	60	5						
AEMRC-RD1003-D32-C32-L250-Z02	●	32	2	32	250	150	5						
AEMRC-RD1003-D33-C32-L160-Z03	●	33	3	32	160	70	5						
AEMRC-RD1003-D40-W32-L150-Z04	●	40	4	32	150	35	5						
AEMRC-RD1003-D40-C32-L250-Z02	●	40	2	32	250	50	5						
AEMRC-RD10T3-D20-C20-L150-Z02	●	20	2	20	150	60	5						
AEMRC-RD10T3-D20-W20-L150-Z02	●	20	2	20	150	60	5						
AEMRC-RD10T3-D25-C25-L150-Z02	●	25	2	25	150	60	5						
AEMRC-RD10T3-D25-C25-L200-Z02-H	●	25	2	25	200	100	5						
AEMRC-RD10T3-D25-W25-L150-Z02	●	25	2	25	150	60	5						
AEMRC-RD10T3-D32-C25-L250-Z03-H	●	32	3	25	250	35	5						
AEMRC-RD10T3-D32-W32-L150-Z03	●	32	3	32	150	60	5						
AEMRC-RD12T3-D25-W25-L150-Z02	●	25	2	25	150	60	6						
AEMRC-RD12T3-D25-W25-L200-Z02	●	25	2	25	200	100	6						
AEMRC-RD12T3-D25-C25-L250-Z02	●	25	2	25	250	150	6						
AEMRC-RD12T3-D25-C25-L300-Z02	●	25	2	25	300	200	6						
AEMRC-RD12T3-D32-W32-L150-Z03	●	32	3	32	150	60	6						
AEMRC-RD12T3-D32-C32-L250-Z02	●	32	2	32	250	150	6						
AEMRC-RD12T3-D40-W32-L150-Z04	●	40	4	32	150	50	6						
AEMRC-RD12T3-D40-C32-L250-Z02	●	40	2	32	250	50	6						
AEMRC-RD1204-D32-C32-L160-Z03	●	32	3	32	160	70	6						
AEMRC-RD1204-D32-W32-L160-Z03	●	32	3	32	160	70	6						
AEMRC-RD1204-D33-C32-L160-Z03	●	33	3	32	160	70	6						
AEMRC-RD1604-D40-W32-L150-Z02	●	40	2	32	150	35	8						
RD.. 1604								4015-M4.5x11	ACK-05	4015-M4x11			

R: Derecha / Droite / Right L: Izquierda / Gauche / Left

● En Existencia / En stock / In Stock ○ Artículo sin Existencia / Indisponible en Stock / Non Stock Item
 Compatible con el Inserto ISO. / Compatible avec ISO Plaquettes. / Compatible with ISO Insert.

Ejemplo de Pedido / Exemple de Commande / Ordering Example

1 Piezas / pcs. / pcs. AEMR-RD0501-D08-W10-L100-Z01-H

Cálculo de Corte : S 369 / Calcul de Coupe : P 369 / Cutting Calculation : 369

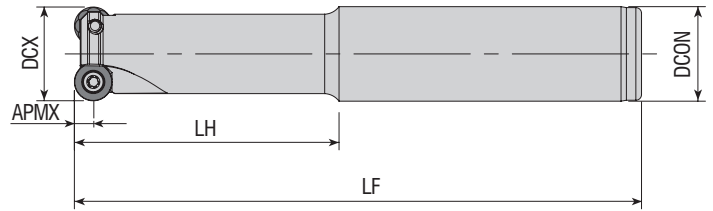

Código del Inserto Le Code de Commande Ordering Code	Stock Stock Stock	Dimension (mm) Dimension (mm) Dimension (mm)						Inserto Plaquette Insert	Recambios / Pièces de Rechange / Spare Parts				
		DCX	ZEFP	DCON	LF	LH	APMX		Tornillo Vis Screw	Abrazadera de Cuiñas Mode de Fixation Wedge Clamp	Tornillo de Sujeción Vis de Fixation Wedge Screw	Llave Torx Clé Torx Torx Wrench	
AEMR-QP10T3-D20-C20-L150-Z01-H	●	20	1	20	150	70	5	QP. 10T3..	4015-M3.5x9	-	-	80-T15	
AEMR-QP10T3-D25-C25-L120-Z02-H	●	25	2	25	120	40	5						
AEMR-QP10T3-D25-C25-L150-Z02-H	●	25	2	25	150	70	5						
AEMR-QP10T3-D25-C25-L170-Z02	●	25	2	25	170	90	5						
AEMR-QP10T3-D32-C32-L150-Z03-H	●	32	3	32	150	70	5						
AEMR-QP10T3-D32-C32-L170-Z03	●	32	3	32	170	90	5						
AEMR-QP1204-D25-C25-L150-Z02-H	●	25	2	25	150	70	6	QP. 1204..	4015-M4x9	-	-		

Compatible con el Inserto SMTM. / Compatible avec SMTM Plaquettes. / Compatible with SMTM Insert.

SISTEMA-S FRESADO EXTREMO DE ALTA ALIMENTACIÓN
 FRAISAGE EN BOUT SYSTEM S A GRANDE VITESSE
 S-SYSTEM HIGHFEED END MILLS

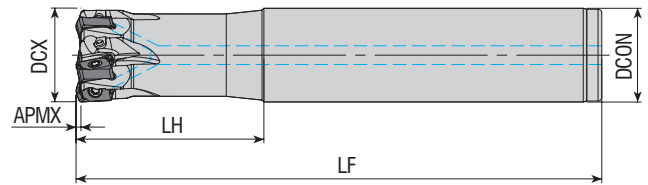

Código del Inserto Le Code de Commande Ordering Code	Stock Stock Stock	Dimension (mm) Dimension (mm) Dimension (mm)						Inserto Plaquette Insert	Recambios / Pièces de Rechange / Spare Parts		
		DCX	ZEFP	DCON	LF	LH	APMX		Tornillo Vis Screw	Llave Torx Clé Torx Torx Wrench	
AHFM-BN10T3-D16-C16-L100-Z02-H	●	16	2	16	100	30	1	BNGX 10T3..	3008-M2.5x6	80-T08	
AHFM-BN10T3-D16-C16-L150-Z02-H	●	16	2	16	150	50	1				
AHFM-BN10T3-D20-C20-L130-Z03-H	●	20	3	20	130	40	1				
AHFM-BN10T3-D20-C20-L130-Z04-H	●	20	4	20	130	40	1				
AHFM-BN10T3-D20-C20-L160-Z03-H	●	20	3	20	160	80	1				
AHFM-BN10T3-D25-C25-L140-Z04-H	●	25	4	25	140	50	1				
AHFM-BN10T3-D25-W25-L140-Z04-H	●	25	4	25	140	50	1				
AHFM-BN10T3-D25-C25-L140-Z05-H	●	25	5	25	140	50	1				
AHFM-BN10T3-D25-C25-L180-Z04-H	●	25	4	25	180	100	1				
AHFM-BN10T3-D32-C32-L150-Z05-H	●	32	5	32	150	70	1				
AHFM-BN10T3-D32-C32-L150-Z06-H	●	32	6	32	150	70	1				
AHFM-BN10T3-D35-C32-L200-Z06-H	●	35	6	32	200	50	1				

R: Derecha / Droite / Right L: Izquierda / Gauche / Left

● En Existencia / En stock / In Stock ○ Artículo sin Existencia / Indisponible en Stock / Non Stock Item
 Compatible con el Inserto PRMT. / Compatible avec PRMT Plaquettes. / Compatible with PRMT Insert.

Ejemplo de Pedido / Exemple de Commande / Ordering Example

1 Piezas / pcs. / pcs. AEMR-QP10T3-D20-C20-L150-Z01-H

Cálculo de Corte : S 369 / Calcul de Coupe : P 369 / Cutting Calculation : 369

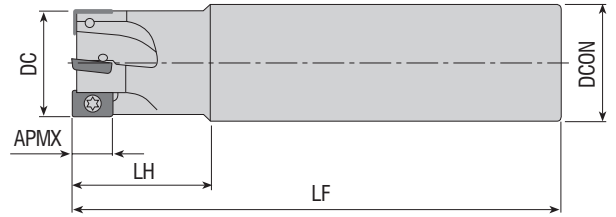

Código del Inserto Le Code de Commande Ordering Code	Stock Stock Stock	Dimension (mm) Dimension (mm) Dimension (mm)						Inserto Plaquette Insert	Recambios / Pièces de Rechange / Spare Parts		
		DC	ZEFP	DCON	LF	LH	APMX		Tornillo Vis Screw	Llave Torx Clé Torx Torx Wrench	
AHFM-E00602-D10-C10-L080-Z02	●	10	2	10	80	20	-	 EO.. 0602.. ZOMT 0602..	 3006-M1.8x4	 80-T06	
AHFM-E00602-D10-C09-L120-Z02	●	10	2	9	120	15	-				
AHFM-E00602-D10-C10-L120-Z02	●	10	2	10	120	60	-				
AHFM-E00602-D12-C12-L080-Z02	●	12	2	12	80	20	-				
AHFM-E00602-D12-C12-L080-Z03	●	12	3	12	80	20	-				
AHFM-E00602-D12-C11-L120-Z02	●	12	2	11	120	15	-				
AHFM-E00602-D12-C11-L120-Z03	●	12	3	11	120	15	-				
AHFM-E00602-D12-C12-L120-Z02	●	12	2	12	120	60	-				
AHFM-E00602-D12-C12-L120-Z03	●	12	3	12	120	60	-				
AHFM-E00602-D16-C16-L150-Z04	●	16	4	16	150	60	-				

Compatible con el Inserto DJT. / Compatible avec DJT Plaquettes. / Compatible with DJT Insert.

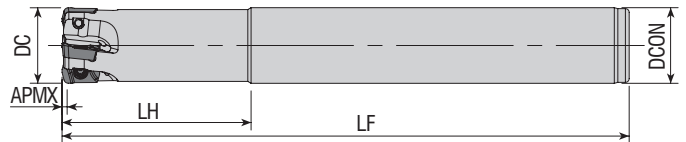

Código del Inserto Le Code de Commande Ordering Code	Stock Stock Stock	Dimension (mm) Dimension (mm) Dimension (mm)						Inserto Plaquette Insert	Recambios / Pièces de Rechange / Spare Parts		
		DC	ZEFP	DCON	LF	LH	APMX		Tornillo Vis Screw	Llave Torx Clé Torx Torx Wrench	
AHFM-EP1003-D16-C16-L150-Z02-H	●	16	2	16	150	50	1	 EP. 1003.. ZPMT 1003.. YPHW 1003..	 3008-M2.5x5	 80-T08	
AHFM-EP1003-D17-C16-L150-Z02-H	●	17	2	16	150	20	1				
AHFM-EP1003-D20-C20-L150-Z04-H	●	20	4	20	150	50	1				
AHFM-EP1003-D21-C20-L150-Z04-H	●	21	4	20	150	20	1				
AHFM-EP1003-D25-C25-L200-Z04-H	●	25	4	25	200	100	1				
AHFM-EP1003-D25-C25-L250-Z04-H	●	25	4	25	250	100	1				

R: Derecha / Droite / Right L: Izquierda / Gauche / Left

● En Existencia / En stock / In Stock ○ Artículo sin Existencia / Indisponible en Stock / Non Stock Item



Compatible con el Inserto DJT. / Compatible avec DJT Plaquettes. / Compatible with DJT Insert.

Ejemplo de Pedido / Exemple de Commande / Ordering Example

1 Piezas / pcs. / pcs. AHFM-E00602-D10-C10-L080-Z02

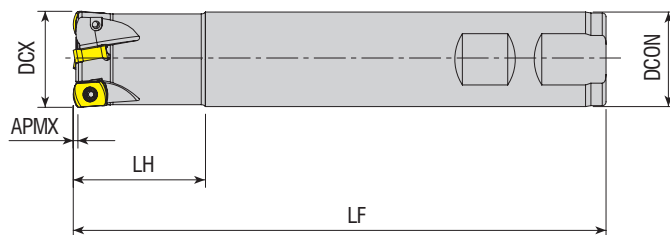
Cálculo de Corte : S 369 / Calcul de Coupe : P 369 / Cutting Calculation : 369

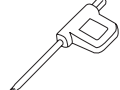

Código del Inserto Le Code de Commande Ordering Code	Stock Stock Stock	Dimension (mm) Dimension (mm) Dimension (mm)						Inserto Plaquette Insert	Recambios / Pièces de Rechange / Spare Parts		
		DCX	ZEFP	DCON	LF	LH	APMX		Tornillo Vis Screw	Llave Torx Clé Torx Torx Wrench	
AHFM-BL0603-D16-C15-L150-Z02	●	16	2	15	150	20	1	 BLMP 0603..	 3008-M2.5x6	 80-T08	
AHFM-BL0603-D16-C16-L100-Z02-H	●	16	2	16	100	30	1				
AHFM-BL0603-D16-C16-L150-Z02	●	16	2	16	150	50	1				
AHFM-BL0603-D17-C16-L150-Z02	●	17	2	16	150	20	1				
AHFM-BL0603-D17-W16-L170-Z02	●	17	2	16	170	20	1				
AHFM-BL0603-D17-W16-L170-Z02-H	●	17	2	16	170	20	1				
AHFM-BL0603-D17-C16-L200-Z02	●	17	2	16	200	30	1				
AHFM-BL0603-D18-C16-L150-Z02	●	18	2	16	150	20	1				
AHFM-BL0603-D18-W16-L150-Z02-H	●	18	2	16	150	20	1				
AHFM-BL0603-D20-C20-L130-Z03	●	20	3	20	130	50	1				
AHFM-BL0603-D20-C20-L160-Z03	●	20	3	20	160	50	1				
AHFM-BL0603-D21-C20-L200-Z03	●	21	3	20	200	25	1				
AHFM-BL0603-D21-W20-L200-Z03	●	21	3	20	200	25	1				
AHFM-BL0603-D22-W20-L150-Z03	●	22	3	20	150	20	1				
AHFM-BL0603-D25-C25-L250-Z04	●	25	4	25	250	40	1				
AHFM-BL0603-D26-C25-L200-Z04	●	26	4	25	200	35	1				
AHFM-BL0603-D26-W25-L200-Z04	●	26	4	25	200	35	1				
AHFM-BL0603-D26-C25-L250-Z04	●	26	4	25	250	35	1				
AHFM-BL0603-D32-C32-L150-Z05	●	32	5	32	150	70	1				
AHFM-BL0603-D32-C32-L200-Z05	●	32	5	32	200	120	1				
AHFM-BL0603-D33-C32-L150-Z05	●	33	5	32	150	40	1				
AHFM-BL0603-D33-C32-L200-Z05	●	33	5	32	200	40	1				
AHFM-BL0603-D33-C32-L250-Z05	●	33	5	32	250	40	1				

R: Derecha / Droite / Right L: Izquierda / Gauche / Left

● En Existencia / En stock / In Stock ○ Artículo sin Existencia / Indisponible en Stock / Non Stock Item
 Compatible con el Inserto TGTC. / Compatible avec TGTC Plaquettes. / Compatible with TGTC Insert.

Ejemplo de Pedido / Exemple de Commande / Ordering Example

1 Piezas / pcs. / pcs. AHFM-BL0603-D16-C15-L150-Z02
 Cálculo de Corte : S 369 / Calcul de Coupe : P 369 / Cutting Calculation : 369

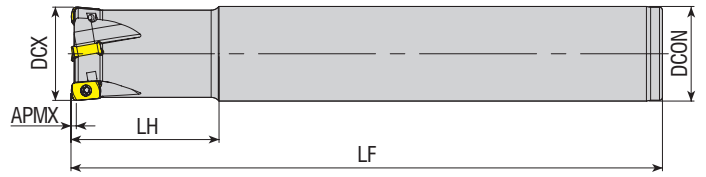

Código del Inserto Le Code de Commande Ordering Code	Stock Stock Stock	Dimension (mm) Dimension (mm) Dimension (mm)						Inserto Plaquette Insert	Recambios / Pièces de Rechange / Spare Parts		
		DCX	ZEFP	DCON	LF	LH	APMX		Tornillo Vis Screw	Llave Torx Clé Torx Torx Wrench	
AHFM-EN1004-D16-C15-L150-Z02	●	16	2	15	150	25	1	ENMU 1004..	3008-M2.5x5	80-T08	
AHFM-EN1004-D16-C16-L150-Z02	●	16	2	16	150	25	1				
AHFM-EN1004-D16-C16-L250-Z02	●	16	2	16	250	70	1				
AHFM-EN1004-D17-C16-L150-Z02-H	●	17	2	16	150	25	1				
AHFM-EN1004-D17-C16-L150-Z02	●	17	2	16	150	25	1				
AHFM-EN1004-D17-C16-L200-Z02	●	17	2	16	200	25	1				
AHFM-EN1004-D18-C16-L150-Z02	●	18	2	16	150	25	1				
AHFM-EN1004-D20-C20-L150-Z03	●	20	3	20	150	40	1				
AHFM-EN1004-D20-C20-L250-Z03	●	20	3	20	250	70	1				
AHFM-EN1004-D21-C20-L150-Z02	●	21	2	20	150	30	1				
AHFM-EN1004-D21-C20-L150-Z03	●	21	3	20	150	30	1				
AHFM-EN1004-D21-C20-L150-Z03-H	●	21	3	20	150	30	1				
AHFM-EN1004-D21-C20-L200-Z03	●	21	3	20	200	30	1				
AHFM-EN1004-D22-C20-L150-Z03	●	22	3	20	150	30	1				
AHFM-EN1004-D25-C25-L150-Z03	●	25	3	25	150	40	1				
AHFM-EN1004-D25-C25-L150-Z04	●	25	4	25	150	40	1				
AHFM-EN1004-D26-C25-L150-Z03	●	26	3	25	150	30	1				
AHFM-EN1004-D26-C25-L150-Z04	●	26	4	25	150	30	1				
AHFM-EN1004-D26-C25-L200-Z03	●	26	3	25	150	30	1				
AHFM-EN1004-D26-C25-L200-Z03-H	●	26	3	25	200	30	1				
AHFM-EN1004-D26-C25-L250-Z03-H	●	26	3	25	250	30	1				
AHFM-EN1004-D28-C25-L200-Z04	●	28	4	25	200	30	1				
AHFM-EN1004-D32-C32-L200-Z04	●	32	4	32	200	50	1				
AHFM-EN1004-D33-C32-L200-Z04	●	33	4	32	200	30	1				
AHFM-EN1004-D33-C32-L200-Z04-H	●	33	4	32	200	30	1				
										3008-M2.5x6	

R: Derecha / Droite / Right L: Izquierda / Gauche / Left

● En Existencia / En stock / In Stock ○ Artículo sin Existencia / Indisponible en Stock / Non Stock Item
 Compatible con el Inserto DJT. / Compatible avec DJT Plaquettes. / Compatible with DJT Insert.





Ejemplo de Pedido / Exemple de Commande / Ordering Example

1 Piezas / pcs. / pcs. AHFM-EN1004-D16-C15-L150-Z02

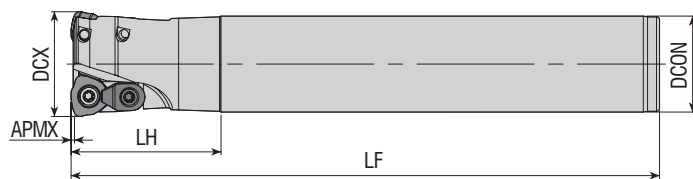
Cálculo de Corte : S 369 / Calcul de Coupe : P 369 / Cutting Calculation : 369





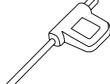

Código del Inserto Le Code de Commande Ordering Code	Stock Stock Stock	Dimension (mm) Dimension (mm) Dimension (mm)						Inserto Plaquette Insert	Recambios / Pièces de Rechange / Spare Parts				
		DCX	ZEFP	DCON	LF	LH	APMX		Tornillo Vis Screw	Abrazadera de Cuñas Mode de Fixation Wedge Clamp	Tornillo de Sujeción Vis de Fixation Wedge Screw	Llave Torx Clé Torx Torx Wrench	
AHFMC-JD1204-D32-C32-L150-Z02	●	32	2	32	150	50	1						
AHFMC-JD1204-D32-C32-L200-Z02	●	32	2	32	200	50	1						
AHFMC-JD1204-D35-C32-L200-Z02	●	35	2	32	200	50	1						
AHFMC-JD1204-D35-C32-L250-Z02	●	35	2	32	250	50	1						

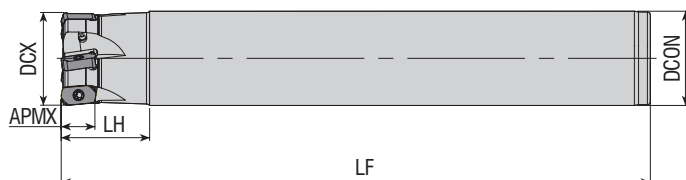
Compatible con el Inserto MTSBH. / Compatible avec MTSBH Plaquettes. / Compatible with MTSBH Insert.

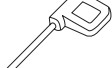

Código del Inserto Le Code de Commande Ordering Code	Stock Stock Stock	Dimension (mm) Dimension (mm) Dimension (mm)						Inserto Plaquette Insert	Recambios / Pièces de Rechange / Spare Parts		
		DCX	ZEFP	DCON	LF	LH	APMX		Tornillo Vis Screw	Llave Torx Clé Torx Torx Wrench	
AHFM-LN0303-D16-C15-L150-Z02	●	16	2	15	150	30	12				
AHFM-LN0303-D16-W16-L150-Z02-H	●	16	2	16	150	50	12				
AHFM-LN0303-D20-W20-L150-Z03-H	●	20	3	20	150	50	12				
AHFM-LN0303-D21-C20-L150-Z03	●	21	3	20	150	30	12				
AHFM-LN0303-D25-W25-L150-Z04-H	●	25	4	25	150	50	12				
AHFM-LN0303-D26-C25-L150-Z04	●	26	4	25	150	30	12				
AHFM-LN0303-D33-C32-L200-Z05	●	33	5	32	200	30	12				

R: Derecha / Droite / Right L: Izquierda / Gauche / Left

● En Existencia / En stock / In Stock ○ Artículo sin Existencia / Indisponible en Stock / Non Stock Item
 Compatible con el Inserto TNGLY. / Compatible avec TNGLY Plaquettes. / Compatible with TNGLY Insert.

Ejemplo de Pedido / Exemple de Commande / Ordering Example

1 Piezas / pcs. / pcs. AHFMC-JD1204-D32-C32-L150-Z02

Cálculo de Corte : S 369 / Calcul de Coupe : P 369 / Cutting Calculation : 369

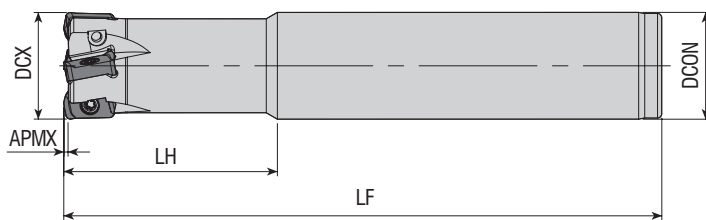

Código del Inserto Le Code de Commande Ordering Code	Stock Stock Stock	Dimension (mm) Dimension (mm) Dimension (mm)						Inserto Plaquette Insert	Recambios / Pièces de Rechange / Spare Parts		
		DCX	ZEFP	DCON	LF	LH	APMX		Tornillo Vis Screw	Llave Torx Clé Torx Torx Wrench	
AHFM-L003-D16-C15-L160-Z02	●	16	2	15	160	30	1	LOGU 0303..	1108-M3x6.8	80-T08	
AHFM-L003-D16-C16-L100-Z02-F	●	16	2	16	100	30	1				
AHFM-L003-D16-C16-L100-Z02	●	16	2	16	100	30	1				
AHFM-L003-D16-C16-L130-Z02-H	●	16	2	16	130	40	1				
AHFM-L003-D16-C16-L160-Z02	●	16	2	16	160	50	1				
AHFM-L003-D16-C16-L160-Z02-H	●	16	2	16	160	100	1				
AHFM-L003-D17-C16-L180-Z02	●	17	2	16	180	30	1				
AHFM-L003-D20-C20-L130-Z03	●	20	3	20	130	40	1				
AHFM-L003-D20-C20-L130-Z03-H	●	20	3	20	130	40	1				
AHFM-L003-D20-C20-L160-Z03	●	20	3	20	160	80	1				
AHFM-L003-D20-C20-L160-Z03-H	●	20	3	20	160	100	1				
AHFM-L003-D21-C20-L150-Z03-H	●	21	3	20	150	30	1				
AHFM-L003-D21-C20-L200-Z03	●	21	3	20	200	30	1				
AHFM-L003-D21-C20-L200-Z03-H	●	21	3	20	200	30	1				
AHFM-L003-D25-C25-L140-Z04-F	●	25	4	25	140	50	1				
AHFM-L003-D25-C25-L140-Z04	●	25	4	25	140	50	1				
AHFM-L003-D25-C25-L180-Z04	●	25	4	25	180	100	1				
AHFM-L003-D26-C25-L250-Z04	●	26	4	25	250	40	1				
AHFM-L003-D32-C32-L200-Z05	●	32	5	32	200	120	1				
AHFM-L003-D33-C32-L250-Z05	●	33	5	32	250	40	1				

R: Derecha / Droite / Right L: Izquierda / Gauche / Left

● En Existencia / En stock / In Stock ○ Artículo sin Existencia / Indisponible en Stock / Non Stock Item

Compatible con el Inserto KYCR. / Compatible avec KYCR Plaquettes. / Compatible with KYCR Insert.

F: El valor de descentramiento axial y radial está dentro de 0,02 mm. / F: Axiale et radiale Runout valeur est dans 0,02 mm.



F: Axial and Radial Runout Value is within 0,02 mm.

Ejemplo de Pedido / Exemple de Commande / Ordering Example

1 Piezas / pcs. / pcs. AHFM-L003-D16-C15-L160-Z02

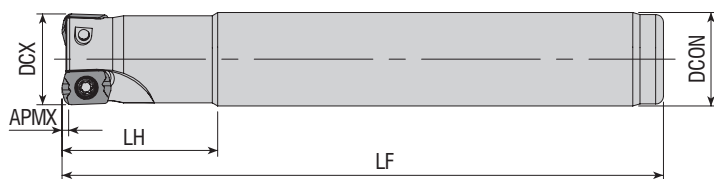



Cálculo de Corte : S 369 / Calcul de Coupe : P 369 / Cutting Calculation : 369

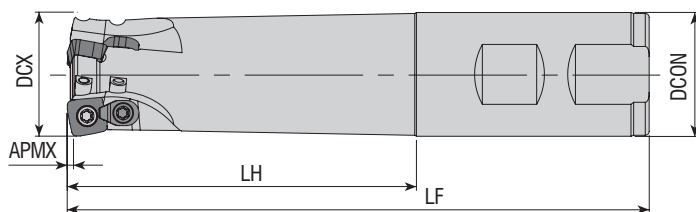

Código del Inserto Le Code de Commande Ordering Code	Stock Stock Stock	Dimension (mm) Dimension (mm) Dimension (mm)						Inserto Plaquette Insert	Recambios / Pièces de Rechange / Spare Parts		
		DCX	ZEFP	DCON	LF	LH	APMX		Tornillo Vis Screw	Llave Torx Clé Torx Torx Wrench	
AHFM-LP0102-D10-C09-L120-Z02	●	10	2	9	120	20	0.5				
AHFM-LP0102-D10-C10-L120-Z02	●	10	2	10	120	20	0.5				
AHFM-LP0102-D12-C11-L120-Z02	●	12	2	11	120	20	0.5				
AHFM-LP0102-D12-C12-L120-Z02	●	12	2	12	120	20	0.5				

Compatible con el Inserto KYCR. / Compatible avec KYCR Plaquettes. / Compatible with KYCR Insert.



Código del Inserto Le Code de Commande Ordering Code	Stock Stock Stock	Dimension (mm) Dimension (mm) Dimension (mm)						Inserto Plaquette Insert	Recambios / Pièces de Rechange / Spare Parts			
		DCX	ZEFP	DCON	LF	LH	APMX		Tornillo Vis Screw	Abrazadera de Cuñas Mode de Fixation Wedge Clamp	Tornillo de Sujeción Vis de Fixation Wedge Screw	Llave Torx Clé Torx Torx Wrench
AHFM-SD06T2-D16-C16-L100-Z02-H	●	16	2	16	100	50	0.8					
AHFM-SD06T2-D16-C16-L150-Z02-H	●	16	2	16	150	50	0.8					
AHFM-SD06T2-D16-C16-L200-Z02	●	16	2	16	200	100	0.8					
AHFM-SD06T2-D17-C16-L150-Z02-H	●	17	2	16	150	50	0.8					
AHFM-SD06T2-D20-C20-L150-Z03-H	●	20	3	20	150	50	0.8					
AHFM-SD06T2-D20-C20-L200-Z03	●	20	3	20	200	100	0.8					
AHFM-SD06T2-D21-C20-L150-Z03-H	●	21	3	20	150	50	0.8					
AHFM-SD06T2-D25-C25-L150-Z04-H	●	25	4	25	150	60	0.8					
AHFM-SD06T2-D26-C25-L150-Z04-H	●	26	4	25	150	60	0.8					
AHFM-SD09T3-D22-W20-L150-Z02	●	22	2	20	150	30	1.4					
AHFM-SD09T3-D25-C25-L150-Z02	●	25	2	25	150	94	1.4					
AHFM-SD09T3-D25-W25-L150-Z02	●	25	2	25	150	94	1.4					
AHFM-SD09T3-D28-C25-L150-Z02	●	28	2	25	150	30	1.4					
AHFM-SD09T3-D32-C32-L150-Z03	●	32	3	32	150	100	1.4					
AHFM-SD09T3-D32-W32-L150-Z03	●	32	3	32	150	90	1.4					
AHFM-SD09T3-D25-C25-L150-Z03	●	25	3	25	150	60	1.4					
AHFM-SD09T3-D32-C32-L150-Z04	●	32	4	25	150	60	1.4					

R: Derecha / Droite / Right L: Izquierda / Gauche / Left

● En Existencia / En stock / In Stock ○ Artículo sin Existencia / Indisponible en Stock / Non Stock Item

Compatible con el Inserto ZCC. / Compatible avec ZCC Plaquettes. / Compatible with ZCC Insert.

Ejemplo de Pedido / Exemple de Commande / Ordering Example

1 Piezas / pcs. / pcs. AHFM-LP0102-D10-C09-L120-Z02

Cálculo de Corte : S 369 / Calcul de Coupe : P 369 / Cutting Calculation : 369

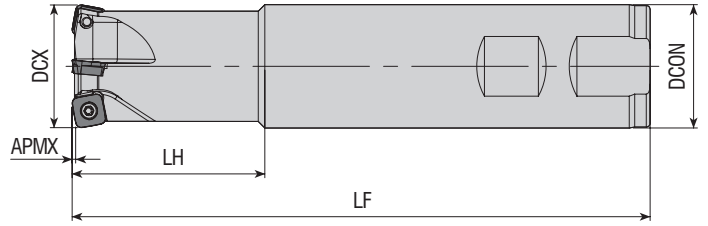

Código del Inserto Le Code de Commande Ordering Code	Stock Stock Stock	Dimension (mm) Dimension (mm) Dimension (mm)						Inserto Plaquette Insert	Recambios / Pièces de Rechange / Spare Parts		
		DCX	ZEFP	DCON	LF	LH	APMX		Tornillo Vis Screw	Llave Torx Clé Torx Torx Wrench	
AHFM-S00803-D20-W20-L150-Z02	●	20	2	20	150	50	-	SOMW 0803..		4010-M3x8	
AHFM-S00803-D25-W25-L150-Z03	●	25	3	25	150	50	-				
AHFM-S00803-D32-W32-L150-Z04	●	32	4	32	150	50	-				

Compatible con el Inserto KPTK. / Compatible avec KPTK Plaquettes. / Compatible with KPTK Insert.

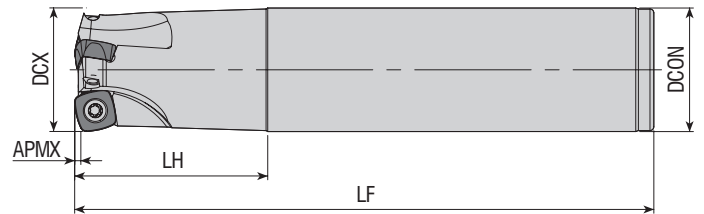



Código del Inserto Le Code de Commande Ordering Code	Stock Stock Stock	Dimension (mm) Dimension (mm) Dimension (mm)						Inserto Plaquette Insert	Recambios / Pièces de Rechange / Spare Parts		
		DCX	ZEFP	DCON	LF	LH	APMX		Tornillo Vis Screw	Llave Torx Clé Torx Torx Wrench	
AHFM-SP1004-D25-C25-L150-Z02	●	25	2	25	150	50	1.5	SPNW 1004..		3015-M3.5x9	
AHFM-SP1004-D32-C32-L150-Z03	●	32	3	32	150	50	1.5				

R: Derecha / Droite / Right L: Izquierda / Gauche / Left
 ● En Existencia / En stock / In Stock ○ Artículo sin Existencia / Indisponible en Stock / Non Stock Item
 Compatible con el Inserto DJT. / Compatible avec DJT Plaquettes. / Compatible with DJT Insert.

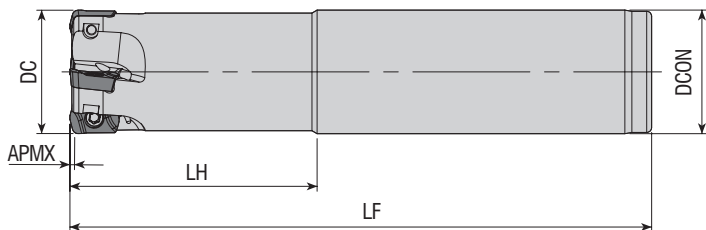
Ejemplo de Pedido / Exemple de Commande / Ordering Example
 1 Piezas / pcs. / pcs. AHFM-S00803-D20-W20-L150-Z02
 Cálculo de Corte : S 369 / Calcul de Coupe : P 369 / Cutting Calculation : 369



Código del Inserto Le Code de Commande Ordering Code	Stock Stock Stock	Dimension (mm) Dimension (mm) Dimension (mm)						Inserto Plaquette Insert	Recambios / Pièces de Rechange / Spare Parts		
		DC	ZEPF	DCON	LF	LH	APMX		Tornillo Vis Screw	Llave Torx Cle Torx Torx Wrench	
AHFM-YP1003-D16-C15-L150-Z02-F	●	16	2	15	150	20	1	 EP. 1003.. YPHW 1003.. ZPMT 1003..	 3008-M2.5x5	 80-T08	
AHFM-YP1003-D16-C15-L200-Z02-F	●	16	2	15	200	20	1				
AHFM-YP1003-D16-C16-L150-Z02-F	●	16	2	16	150	50	1				
AHFM-YP1003-D17-C16-L150-Z02-F	●	17	2	16	150	20	1				
AHFM-YP1003-D17-C16-L200-Z02-F	●	17	2	16	200	20	1				
AHFM-YP1003-D20-C18-L150-Z03-F	●	20	3	18	150	25	1				
AHFM-YP1003-D20-C18-L200-Z03-F	●	20	3	18	200	25	1				
AHFM-YP1003-D20-C20-L150-Z03-F	●	20	3	20	150	50	1				
AHFM-YP1003-D21-C20-L150-Z03-F	●	21	3	20	150	20	1				
AHFM-YP1003-D21-C20-L150-Z03-H	●	21	3	20	150	20	1				
AHFM-YP1003-D21-C20-L150-Z04-F	●	21	4	20	150	20	1				
AHFM-YP1003-D21-C20-L200-Z03	●	21	3	20	200	20	1				
AHFM-YP1003-D21-C20-L200-Z03-F	●	21	3	20	200	20	1				
AHFM-YP1003-D25-C20-L150-Z04-F	●	25	4	20	150	25	1				
AHFM-YP1003-D25-C20-L200-Z04-F	●	25	4	20	200	25	1				
AHFM-YP1003-D25-C25-L150-Z04-F	●	25	4	25	150	50	1				
AHFM-YP1003-D26-C25-L150-Z04	●	26	4	25	150	30	1				
AHFM-YP1003-D26-C25-L150-Z04-F	●	26	4	25	150	30	1				
AHFM-YP1003-D26-C25-L200-Z03-F	●	26	3	25	200	30	1				
AHFM-YP1003-D26-C25-L200-Z04-F	●	26	4	25	200	30	1				

R: Derecha / Droite / Right L: Izquierda / Gauche / Left

● En Existencia / En stock / In Stock ○ Artículo sin Existencia / Indisponible en Stock / Non Stock Item
 Compatible con el Inserto DJT. / Compatible avec DJT Plaquettes. / Compatible with DJT Insert.

El tamaño del diámetro se produce como - 0,02 mm. F: significa ± 0,02 mm. Por ejemplo: herramienta Ø16 15,98 ± 0,02 mm, significa que debe ser de 16,00 mm - 15,96 mm.

Taille diamètre est produit comme - 0,02 mm. F: des moyens ± 0,02 mm. Par exemple: Ø16 outil 15,98 ± 0,02 mm, cela signifie qu'il devrait être mm 16,00 - 15,96 mm.

Diameter Size is produced as - 0.02 mm. F: means ± 0,02 mm. For example: Ø16 tool 15.98 ± 0,02 mm, it means that it should be 16,00 mm - 15,96 mm.



Ejemplo de Pedido / Exemple de Commande / Ordering Example

1 Piezas / pcs. / pcs. AHFM-YP1003-D16-C15-L150-Z02-F

Cálculo de Corte : S 369 / Calcul de Coupe : P 369 / Cutting Calculation : 369

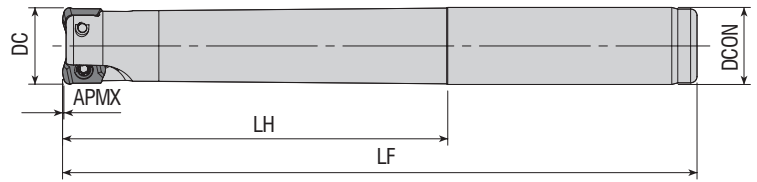







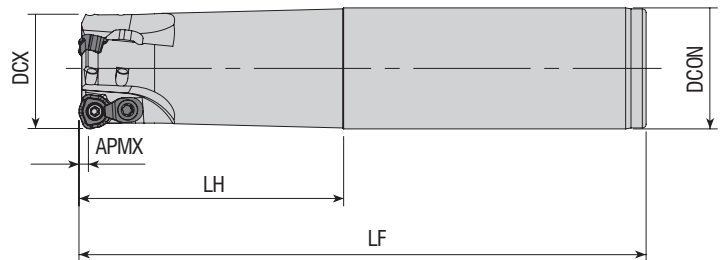



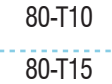

Código del Inserto Le Code de Commande Ordering Code	Stock Stock Stock	Dimension (mm) Dimension (mm) Dimension (mm)						Inserto Plaquette Insert	Recambios / Pièces de Rechange / Spare Parts		
		DC	ZEPF	DCON	LF	LH	APMX		Tornillo Vis Screw	Llave Torx Clé Torx Torx Wrench	
AHFM-Y00602-D10-C09-L120-Z02-F	●	10	2	9	120	15	0.3	 YOHW 0602..	 3006-M1.8X4	 80-T06	
AHFM-Y00602-D10-C10-L080-Z02-F	●	10	2	10	80	20	0.3				
AHFM-Y00602-D10-C10-L120-Z02-F	●	10	2	10	120	60	0.3				
AHFM-Y00602-D10-C10-L120-Z02-H-F	●	10	2	10	120	60	0.3				
AHFM-Y00602-D10-C10-L120-Z02-H	●	10	2	10	120	60	0.3				
AHFM-Y00602-D12-C11-L120-Z02-F	●	12	2	11	120	15	0.3				
AHFM-Y00602-D12-C11-L120-Z02-H-F	●	12	2	11	120	15	0.3				
AHFM-Y00602-D12-C11-L120-Z02-H	●	12	2	11	120	15	0.3				
AHFM-Y00602-D12-C11-L120-Z03-F	●	12	3	11	120	15	0.3				
AHFM-Y00602-D12-C12-L080-Z02-F	●	12	2	12	80	20	0.3				
AHFM-Y00602-D12-C12-L080-Z03-F	●	12	3	12	80	20	0.3				
AHFM-Y00602-D12-C12-L120-Z02-F	●	12	2	12	120	60	0.3				
AHFM-Y00602-D12-C12-L120-Z02-H	●	12	2	12	120	60	0.3				
AHFM-Y00602-D12-C12-L120-Z03-F	●	12	3	12	120	60	0.3				
AHFM-Y00602-D12-C12-L120-Z03-H	●	12	3	12	120	60	0.3				

Compatible con el Inserto DJT. / Compatible avec DJT Plaquettes. / Compatible with DJT Insert.
 F: El valor de descentramiento axial y radial está dentro de 0,02 mm. / F: Axiale et radiale Runout valeur est dans 0,02 mm.
 F: Axial and Radial Runout Value is within 0,02 mm.

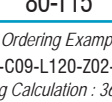

Código del Inserto Le Code de Commande Ordering Code	Stock Stock Stock	Dimension (mm) Dimension (mm) Dimension (mm)						Inserto Plaquette Insert	Recambios / Pièces de Rechange / Spare Parts			
		DCX	ZEPF	DCON	LF	LH	APMX		Tornillo Vis Screw	Abrazadera de Cuñas Mode de Fixation Wedge Clamp	Tornillo de Sujeción Vis de Fixation Wedge Screw	Llave Torx Clé Torx Torx Wrench
AHFM-WD0603-D16-C16-L150-Z02	●	16	2	16	150	70	2	 WDMT 0603..	 3008-M2.5x6	-	-	 80-T08
AHFM-WD0603-D20-C20-L150-Z03	●	20	3	20	150	70	2					
AHFMC-WD0804-D25-C25-L150-Z02	●	25	2	25	150	70	1.5	 WDMT 0804..	 4010-M3x8	 ACK-15	 4010-M3x8	 80-T10
AHFMC-WD0804-D32-C32-L150-Z03	●	32	3	32	150	70	1.5					
AHFMC-WD1205-D32-C32-L150-Z02	●	32	2	32	150	70	3	 WDMT 1205..	 1415-M4x11	 ACK-05	 4015-M4x11	 80-T15

R: Derecha / Droite / Right L: Izquierda / Gauche / Left

● En Existencia / En stock / In Stock ○ Artículo sin Existencia / Indisponible en Stock / Non Stock Item
 Compatible con el Inserto SMTM. / Compatible avec SMTM Plaquettes. / Compatible with SMTM Insert.

Ejemplo de Pedido / Exemple de Commande / Ordering Example

1 Piezas / pcs. / pcs. AHFM-Y00602-D10-C09-L120-Z02-F

Cálculo de Corte : S 369 / Calcul de Coupe : P 369 / Cutting Calculation : 369

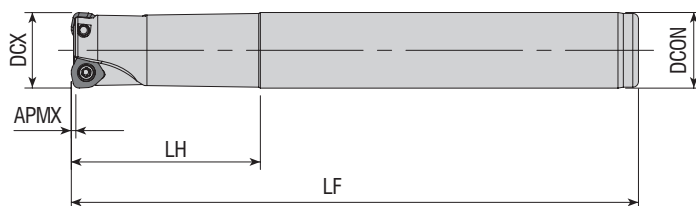

Código del Inserto Le Code de Commande Ordering Code	Stock Stock Stock	Dimension (mm) Dimension (mm) Dimension (mm)						Inserto Plaquette Insert	Recambios / Pièces de Rechange / Spare Parts				
		DCX	ZEFP	DCON	LF	LH	APMX		Tornillo Vis Screw	Abrazadera de Cuñas Mode de Fixation Wedge Clamp	Tornillo de Sujeción Vis de Fixation Wedge Screw	Llave Torx Clé Torx Torx Wrench	
AHFM-WD0503D-D20-C20-L150-Z02	●	20	2	20	150	50	1.25	WD.W 0503..	4010-M3x6	-	-	80-T10	
AHFM-WD0503D-D21-C20-L150-Z02	●	21	2	20	150	30	1.25						
AHFMC-WD06T3D-D26-C25-L200-Z02	●	26	2	25	200	30	1.5	WD.W 06T3..	3015-M3.5x9	ACK-15	4015-M3.5x11	80-T15	
AHFMC-WD06T3D-D33-C32-L200-Z03	●	33	3	32	200	32	1.5						

Compatible con el Inserto DJT. / Compatible avec DJT Plaquettes. / Compatible with DJT Insert.

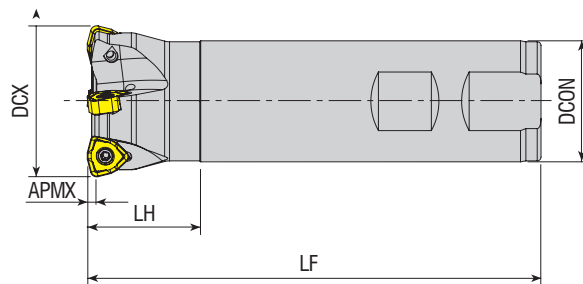

Código del Inserto Le Code de Commande Ordering Code	Stock Stock Stock	Dimension (mm) Dimension (mm) Dimension (mm)						Inserto Plaquette Insert	Tornillo Vis Screw	Llave Torx Clé Torx Torx Wrench
		DCX	ZEFP	DCON	LF	LH	APMX			
AHFM-WN0603-D16-C16-L110-Z02-H	●	16	2	16	110	30	1	WNMX 0603..	3008-M2.5x6	80-T08
AHFM-WN0603-D16-C16-L150-Z02-H	●	16	2	16	150	70	1			
AHFM-WN0603-D17-C16-L150-Z02-H	●	17	2	16	150	20	1			
AHFM-WN0603-D20-C20-L150-Z02-H	●	20	2	20	150	70	1			
AHFM-WN0603-D20-C20-L200-Z02-H	●	20	2	20	200	100	1			
AHFM-WN0603-D21-C20-L150-Z02-H	●	21	2	20	150	20	1			
AHFM-WN09T3-D25-W25-L120-Z02-H	●	25	2	25	120	40	1.5	WNMX 09T3..	4010-M3x8	80-T10
AHFML-WN09T3-D25-W25-L120-Z02-H	●	25	2	25	120	40	1.5			
AHFM-WN09T3-D25-C25-L200-Z02	●	25	2	25	200	120	1.5			
AHFM-WN09T3-D32-W32-L120-Z03-H	●	32	3	32	120	30	1.5			
AHFM-WN09T3-D32-W32-L200-Z03-H	○	32	3	32	200	100	1.5			
AHFM-WN09T3-D35-W32-L200-Z04-H	●	35	4	32	200	50	1.5			
AHFM-WN09T3-D40-W32-L120-Z04-H	●	40	4	32	120	30	1.5			
AHFM-WN09T3-D40-C32-L200-Z04	●	40	4	32	200	30	1.5			
AHFM-WN1305-D32-C32-L150-Z02-H	○	32	2	32	150	70	2	WNMX 1305..	4015-M4x11	80-T15
AHFM-WN1305-D32-C32-L200-Z02-H	●	32	2	32	200	120	2			
AHFM-WN1305-D40-C32-L200-Z03-H	●	40	3	32	200	30	2			

R: Derecha / Droite / Right L: Izquierda / Gauche / Left

● En Existencia / En stock / In Stock ○ Artículo sin Existencia / Indisponible en Stock / Non Stock Item
 Compatible con el Inserto KRLY. / Compatible avec KRLY Plaquettes. / Compatible with KRLY Insert.

Ejemplo de Pedido / Exemple de Commande / Ordering Example

1 Piezas / pcs. / pcs. AHFM-WD0503D-D20-C20-L150-Z02
 Cálculo de Corte : S 369 / Calcul de Coupe : P 369 / Cutting Calculation : 369

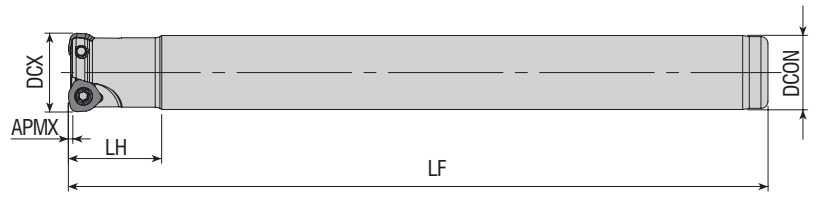

Código del Inserto Le Code de Commande Ordering Code	Stock Stock Stock	Dimension (mm) Dimension (mm) Dimension (mm)						Inserto Plaquette Insert	Recambios / Pièces de Rechange / Spare Parts		
		DCX	ZEPF	DCON	LF	LH	APMX		Tornillo Vis Screw	Llave Torx Clé Torx Torx Wrench	
AHFM-W004T2D-D16-C16-L150-Z02	●	16	2	16	150	20	0.8				
AHFM-W004T2D-D17-C16-L150-Z02	●	17	2	16	150	20	0.8				

Compatible con el Inserto DJT. / Compatible avec DJT Plaquettes. / Compatible with DJT Insert.

S-SISTEMA FRESAS MODULARES (HERRAMIENTAS TIPO TORNILLO)
 FRAISAGE EN BOUT MODULAIRE SYSTEM S (OUTILS DE TYPE A VIS)
 S-SYSTEM MODULAR END MILLS (SCREW TYPE TOOLS)

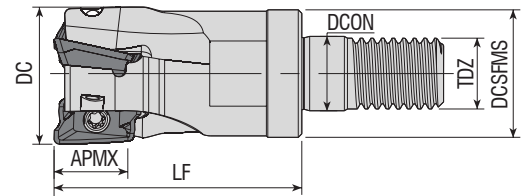

Código del Inserto Le Code de Commande Ordering Code	Stock Stock Stock	Dimension (mm) Dimension (mm) Dimension (mm)							Inserto Plaquette Insert	Recambios / Pièces de Rechange / Spare Parts		
		DC	Z	DCSFMS	TDZ	LF	DCON	APMX		Tornillo Vis Screw	Llave Torx Clé Torx Torx Wrench	
AEM90-A01236-D16-M08-L30-Z02	●	16	2	14.8	M08	30	8.5	10				
AEM90-A01236-D20-M10-L35-Z03	●	20	3	18	M10	35	10.5	10				

R: Derecha / Droite / Right L: Izquierda / Gauche / Left

● En Existencia / En stock / In Stock ○ Artículo sin Existencia / Indisponible en Stock / Non Stock Item

Compatible con el Inserto MTSBH. / Compatible avec MTSBH Plaquettes. / Compatible with MTSBH Insert.

Ejemplo de Pedido / Exemple de Commande / Ordering Example

1 Piezas / pcs. / pcs. AHFM-W004T2D-D16-C16-L150-Z02

Cálculo de Corte : S 369 / Calcul de Coupe : P 369 / Cutting Calculation : 369

Par de Apriete : S 368 / Couple de Serrage : P 368 / Tightening Torque: 368

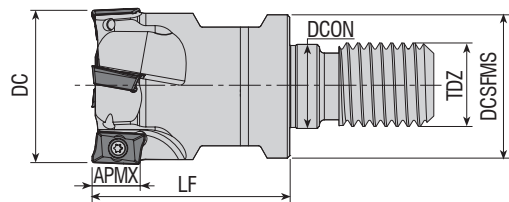

Código del Inserto Le Code de Commande Ordering Code	Stock Stock Stock	Dimension (mm) Dimension (mm) Dimension (mm)							Recambios / Pièces de Rechange / Spare Parts		
		DC	ZEP	DCSFMS	TDZ	LF	DCON	APMX	Inserto Plaquette Insert	Tornillo Vis Screw	Llave Torx Clé Torx Torx Wrench
AEM90-AD1505D-D25-M12-L43-Z02-H	●	25	2	21	M12	43	12.5	14.3	ADKT 150508	4015-M4x9 4015-M4x11	80-T15
AEM90-AD1505D-D32-M16-L43-Z03-H	●	32	3	29	M16	43	17	14.3			

Compatible con el Inserto DJT. / Compatible avec DJT Plaquettes. / Compatible with DJT Insert.

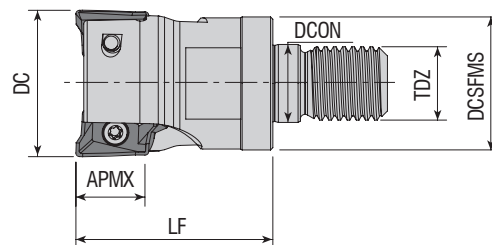
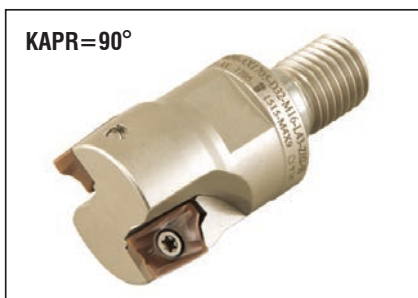

Código del Inserto Le Code de Commande Ordering Code	Stock Stock Stock	Dimension (mm) Dimension (mm) Dimension (mm)							Recambios / Pièces de Rechange / Spare Parts		
		DC	ZEP	DCSFMS	TDZ	LF	DCON	APMX	Inserto Plaquette Insert	Tornillo Vis Screw	Llave Torx Clé Torx Torx Wrench
AEM90-AX1235-D16-M08-L30-Z02-H	●	16	2	14.75	M08	30	8.5	10	AX.T 1235..	3108-M3x6	80-T08
AEM90-AX1235-D20-M10-L30-Z03-H	●	20	3	18	M10	30	10.5	10			
AEM90-AX1235-D25-M12-L35-Z04-H	●	25	4	21	M12	35	12.5	10	AX.T 1705..	4015-M4x9	80-T15
AEM90-AX1705-D25-M12-L43-Z02-H	●	25	2	21	M12	43	12.5	14			
AEM90-AX1705-D32-M16-L43-Z02-H	●	32	2	29	M16	43	17	14			

R: Derecha / Droite / Right L: Izquierda / Gauche / Left

● En Existencia / En stock / In Stock ○ Artículo sin Existencia / Indisponible en Stock / Non Stock Item
 Compatible con el Inserto SMTM. / Compatible avec SMTM Plaquettes. / Compatible with SMTM Insert.







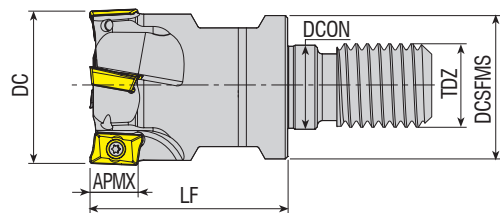

Ejemplo de Pedido / Exemple de Commande / Ordering Example

1 Piezas / pcs. / pcs. AEM90-AD1505D-D25-M12-L43-Z02-H

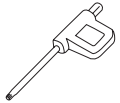
Cálculo de Corte : S 369 / Calcul de Coupe : P 369 / Cutting Calculation : 369

Par de Apriete : S 368 / Couple de Serrage : P 368 / Tightening Torque: 368



Código del Inserto Le Code de Commande Ordering Code	Stock Stock Stock	Dimension (mm) Dimension (mm) Dimension (mm)							Inserto Plaquette Insert	Tornillo Vis Screw	Llave Torx Clé Torx Torx Wrench
		DC	ZEFP	DCSFMS	TDZ	LF	DCON	APMX			
AEM90-AP0903-D20-M12-L35-Z03	●	20	3	18	M12	35	12.5	9	 APMT 0903.. Para Inserto KRLY. POUR KRLY PLAQUETTES. FOR KRLY INSERT.		
AEM90-AP0903-D25-M12-L35-Z03	●	25	3	21	M12	35	12.5	9			
AEM90-AP10-D16-M08-L30-Z02-H	●	16	2	14.75	M08	30	8.5	10	 AP. 1003.. Compatible con el Inserto ISO. Compatible avec ISO Plaqueettes. FOR ISO INSERT.	3008-M2.5x6	80-T08
AEM90-AP10-D20-M10-L30-Z03-H	●	20	3	18	M10	30	10.5	10			
AEM90-AP10-D25-M12-L35-Z03-H	●	25	3	21	M12	35	12.5	10			
AEM90-AP10-D32-M16-L35-Z04-H	●	32	4	29	M16	35	17	10			
AEM90-AP10-D32-M16-L40-Z04-H	●	32	4	29	M16	40	17	10			
AEM90-AP10-D40-M16-L43-Z05-H	●	40	5	29	M16	43	17	10			
AEM90-AP10-D42-M16-L43-Z05-H	●	42	5	29	M16	43	17	10			
AEM90-AP10D-D16-M08-L30-Z02-H	●	16	2	14.75	M08	30	8.5	10			
AEM90-AP10D-D20-M10-L30-Z03-H	●	20	3	18	M10	30	10.5	10			
AEM90-AP10D-D25-M12-L35-Z03-H	●	25	3	21	M12	35	12.5	10			
AEM90-AP11-D16-M08-L30-Z02-H	●	16	2	14.75	M08	30	8.5	11	 AP. 11T3.. Compatible con el Inserto ZCC. Compatible avec ZCC Plaqueettes. FOR ZCC INSERT.	4015-M4x9	80-T15
AEM90-AP11-D20-M10-L30-Z03-H	●	20	3	18	M10	30	10.5	11			
AEM90-AP11-D25-M12-L35-Z03-H	●	25	3	21	M12	35	12.5	11			
AEM90-AP11-D32-M16-L35-Z04-H	●	32	4	29	M16	35	17	11			
AEM90-AP11-D40-M16-L43-Z05-H	●	40	5	29	M16	43	17	11			
AEM90-AP16-D25-M12-L43-Z02-H	●	25	2	21	M12	43	12.5	16	 APMT 1604.. Compatible con el Inserto ISO. Compatible avec ISO Plaqueettes. FOR ISO INSERT.	4015-M4x9	80-T15
AEM90-AP16-D32-M16-L43-Z03-H	●	32	3	29	M16	43	17	16			
AEM90-AP16-D40-M16-L43-Z04-H	●	40	4	29	M16	43	17	16	 AP. 1604.. Compatible con el Inserto DJT. Compatible avec DJT Plaqueettes. FOR DJT INSERT.	4015-M4x9	80-T15
AEM90-AP16D-D25-M12-L43-Z02-H	●	25	2	21	M12	43	12.5	16			
AEM90-AP16DJ-D32-M16-L43-Z03-H	●	32	3	29	M16	43	17	16	 AP. 1604.. Compatible con el Inserto LMN. Compatible avec LMN Plaqueettes. FOR LMN INSERT.	4015-M4x9	80-T15
AEM90-AP16DJ-D40-M16-L43-Z04-H	●	40	4	29	M16	43	17	16			
AEM90-AP16L-D25-M12-L43-Z02-H	●	25	2	21	M12	43	12.5	16	 AP. 1604.. Compatible con el Inserto LMN. Compatible avec LMN Plaqueettes. FOR LMN INSERT.	4015-M4x9	80-T15
AEM90-AP16L-D32-M16-L43-Z03-H	●	32	3	29	M16	43	17	16			
AEM90-AP16L-D40-M16-L43-Z04-H	●	40	4	29	M16	43	17	16			

R: Derecha / Droite / Right L: Izquierda / Gauche / Left

● En Existencia / En stock / In Stock ○ Artículo sin Existencia / Indisponible en Stock / Non Stock Item

Ejemplo de Pedido / Exemple de Commande / Ordering Example

1 Piezas / pcs. / pcs. AEM90-AP0903-D20-M12-L35-Z03

Cálculo de Corte : S 369 / Calcul de Coupe : P 369 / Cutting Calculation : 369

Par de Apriete : S 368 / Couple de Serrage : P 368 / Tightening Torque : 368

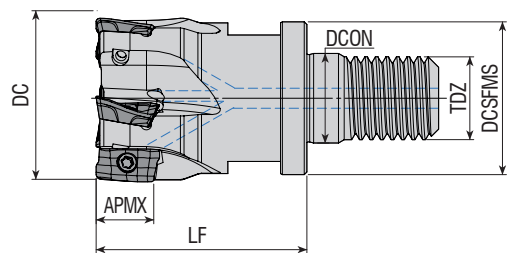

Código del Inserto Le Code de Commande Ordering Code	Stock Stock Stock	Dimension (mm) Dimension (mm) Dimension (mm)							Inserto Plaqueette Insert	Recambios / Pièces de Rechange / Spare Parts		
		DC	ZEFP	DCSFMS	TDZ	LF	DCON	APMX		Tornillo Vis Screw	Llave Torx Clé Torx Torx Wrench	
AEM90-BD11T3-D16-M08-L25-Z02-H	●	16	2	14.75	M08	25	8.5	10				
AEM90-BD11T3-D25-M12-L35-Z04-H	●	25	4	21	M12	35	12.5	10				
AEM90-BD11T3-D32-M16-L40-Z05-H	●	32	5	29	M16	40	17	10				

Compatible con el Inserto KYCR. / Compatible avec KYCR Plaquettes. / Compatible with KYCR Insert.

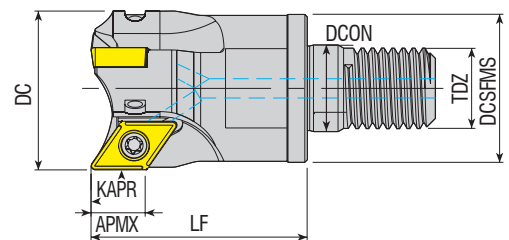

Código del Inserto Le Code de Commande Ordering Code	Stock Stock Stock	Dimension (mm) Dimension (mm) Dimension (mm)							Inserto Plaqueette Insert	Recambios / Pièces de Rechange / Spare Parts		
		DC	ZEFP	DCSFMS	TDZ	LF	DCON	APMX		Tornillo Vis Screw	Llave Torx Clé Torx Torx Wrench	
AEM90-DC07-D20-M10-L30-Z02-H	●	20	2	18	M10	30	10.5	7				
AEM90-DC07-D25-M12-L35-Z03-H	●	25	3	21	M12	35	12.5	7				
AEM90-DC07-D32-M16-L43-Z04-H	●	32	4	29	M16	43	17	7				
AEM90-DC07-D40-M16-L43-Z05-H	●	40	5	29	M16	43	17	7				
AEM90-DC11-D32-M16-L43-Z03-H-F	●	32	3	29	M16	43	17	11				
AEM90-DC11-D40-M16-L43-Z03-H-F	●	40	3	29	M16	43	17	11				

R: Derecha / Droite / Right L: Izquierda / Gauche / Left

● En Existencia / En stock / In Stock ○ Artículo sin Existencia / Indisponible en Stock / Non Stock Item
 Compatible con el Inserto ISO. / Compatible avec ISO Plaquettes. / Compatible with ISO Insert.

F: El valor de descentramiento axial y radial está dentro de 0,02 mm. / F: Axiale and radiale Runout valeur est dans 0,02 mm.

F: Axial and Radial Runout Value is within 0,02 mm.

Ejemplo de Pedido / Exemple de Commande / Ordering Example

1 Piezas / pcs. / pcs. AEM90-BD11T3-D16-M08-L25-Z02-H

Cálculo de Corte : S 369 / Calcul de Coupe : P 369 / Cutting Calculation : 369

Par de Apriete : S 368 / Couple de Serrage : P 368 / Tightening Torque: 368



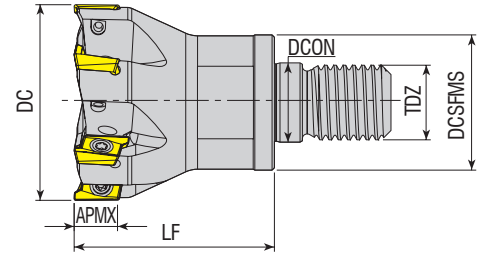

Código del Inserto Le Code de Commande Ordering Code	Stock Stock	Dimension (mm) Dimension (mm) Dimension (mm)							Inserto Plaquette Insert	Recambios / Pièces de Rechange / Spare Parts	
		DC	ZEFP	DCSFMS	TDZ	LF	DCON	APMX		Tornillo Vis Screw	Llave Torx Clé Torx Torx Wrench
AEM90-RT10-D16-M08-L20-Z02-H	●	16	2	14.75	M08	20	8.5	10			
AEM90-RT10-D20-M10-L25-Z03-H	●	20	3	18	M10	25	10.5	10			
AEM90-RT10-D25-M12-L30-Z04-H	●	25	4	21	M12	30	12.5	10			
AEM90-RT10-D32-M16-L43-Z05-H	●	32	5	29	M16	43	17	10			
AEM90-RT10-D42-M16-L43-Z06-H	●	42	6	29	M16	43	17	10			

Compatible con el Inserto SFTY. / Compatible avec SFTY Plaquettes. / Compatible with SFTY Insert.

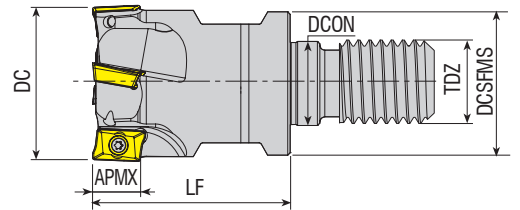

Código del Inserto Le Code de Commande Ordering Code	Stock Stock	Dimension (mm) Dimension (mm) Dimension (mm)							Inserto Plaquette Insert	Recambios / Pièces de Rechange / Spare Parts	
		DC	ZEFP	DCSFMS	TDZ	LF	DCON	APMX		Tornillo Vis Screw	Llave Torx Clé Torx Torx Wrench
AEM90-R390.11-D16-M08-L30-Z02-H	●	16	2	14.75	M08	30	8.5	10		3008-M2.5x5	
AEM90-R390.11-D20-M10-L30-Z03-H	●	20	3	18	M10	30	10.5	10		3008-M2.5x6	
AEM90-R390.11-D25-M12-L35-Z03-H	●	25	3	21	M12	35	12.5	10			
AEM90-R390.11-D32-M16-L43-Z04-H	●	32	4	29	M16	43	17	10			

R: Derecha / Droite / Right L: Izquierda / Gauche / Left

● En Existencia / En stock / In Stock ○ Artículo sin Existencia / Indisponible en Stock / Non Stock Item
 Compatible con el Inserto SNDVK. / Compatible avec SNDVK Plaquettes. / Compatible with SNDVK Insert.

Ejemplo de Pedido / Exemple de Commande / Ordering Example

1 Piezas / pcs. / pcs. AEM90-RT10-D16-M08-L20-Z02-H

Cálculo de Corte : S 369 / Calcul de Coupe : P 369 / Cutting Calculation : 369

Par de Apriete : S 368 / Couple de Serrage : P 368 / Tightening Torque : 368



KAPR=90°

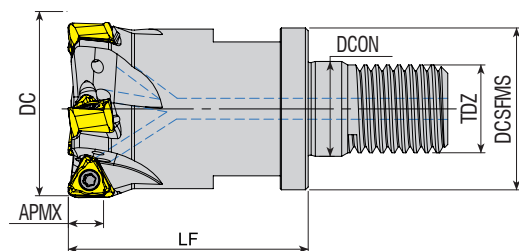

Código del Inserto Le Code de Commande Ordering Code	Stock Stock Stock	Dimension (mm) Dimension (mm) Dimension (mm)							Inserto Plaquette Insert	Recambios / Pièces de Rechange / Spare Parts	
		DC	ZEFP	DCSFMS	TDZ	LF	DCON	APMX		Tornillo Vis Screw	Llave Torx Clé Torx Torx Wrench
AEM90-TNG10-D21-M10-L25-Z03-H	●	21	3	18	M10	25	10.5	5			
AEM90-TNG10-D26-M12-L30-Z04-H	●	26	4	21	M12	30	12.5	5			
AEM90-TNG10-D33-M16-L43-Z05-H	●	33	5	29	M16	43	17	5			
AEM90-TNG10-D35-M16-L43-Z05-H	●	35	5	29	M16	43	17	5			

Compatible con el Inserto PRMT. / Compatible avec PRMT Plaquettes. / Compatible with PRMT Insert.

KAPR=90°

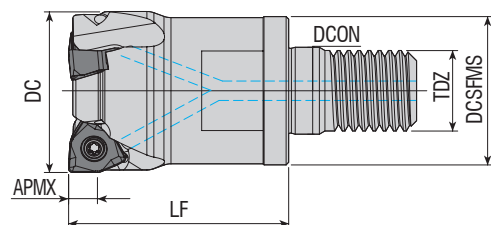

Código del Inserto Le Code de Commande Ordering Code	Stock Stock Stock	Dimension (mm) Dimension (mm) Dimension (mm)							Inserto Plaquette Insert	Recambios / Pièces de Rechange / Spare Parts	
		DC	ZEFP	DCSFMS	TDZ	LF	DCON	APMX		Tornillo Vis Screw	Llave Torx Clé Torx Torx Wrench
AEM90-WN0604Z-D25-M12-L35-Z02-H	●	25	2	21	M12	35	12.5	5.7			
AEM90-WN0604Z-D32-M16-L43-Z03-H	●	32	3	29	M16	43	17	5.7			
AEM90-WN0604Z-D40-M16-L43-Z04-H	●	40	4	29	M16	43	17	5.7			

R: Derecha / Droite / Right L: Izquierda / Gauche / Left

● En Existencia / En stock / In Stock ○ Artículo sin Existencia / Indisponible en Stock / Non Stock Item
 Compatible con el Inserto ZCC. / Compatible avec ZCC Plaquettes. / Compatible with ZCC Insert.

Ejemplo de Pedido / Exemple de Commande / Ordering Example

1 Piezas / pcs. / pcs. AEM90-TNG10-D21-M10-L25-Z03-H
 Cálculo de Corte : S 369 / Calcul de Coupe : P 369 / Cutting Calculation : 369
 Par de Apriete : S 368 / Couple de Serrage : P 368 / Tightening Torque: 368

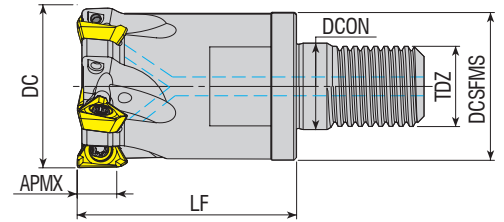

Código del Inserto Le Code de Commande Ordering Code	Stock Stock Stock	Dimension (mm) Dimension (mm) Dimension (mm)							Inserto Plaquette Insert	Recambios / Pièces de Rechange / Spare Parts		
		DC	ZEFP	DCSFMS	TDZ	LF	DCON	APMX		Tornillo Vis Screw	Llave Torx Clé Torx Torx Wrench	
AEM90-3P1004-D20-M10-L35-Z02	●	20	2	18	10	35	10.5	7	3PT 1004	1108-M2.5x6	80-T08	
AEM90-3P1004-D32-M16-L43-Z05-H	●	32	5	29	16	43	17	7				

Compatible con el Inserto TGTC. / Compatible avec TGTC Plaquettes. / Compatible with TGTC Insert.

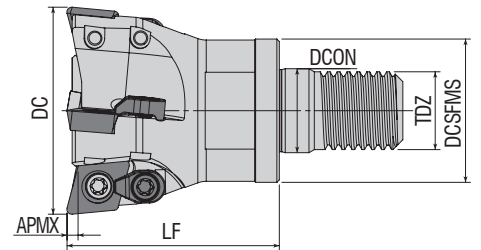

Código del Inserto Le Code de Commande Ordering Code	Stock Stock Stock	Dimension (mm) Dimension (mm) Dimension (mm)							Inserto Plaquette Insert	Recambios / Pièces de Rechange / Spare Parts			
		DC	ZEFP	DCSFMS	TDZ	LF	DCON	APMX		Tornillo Vis Screw	Abrazadera de Cuiñas Mode de Fixation Wedge Clamp	Tornillo de Sujeción Vis de Fixation Wedge Screw	Llave Torx Clé Torx Torx Wrench
AEM95-XD0206-D16-M08-L23-Z02-H	●	16	2	14.75	M08	23	8.5	1	XDHW 0206..	3008-M2.5x5	-	-	80-T08
AEM95-XD0206-D16-M08-L23-Z02-H-F	●	16	2	14.75	M08	23	8.5	1					
AEM95-XD0206-D20-M10-L30-Z03-H	●	20	3	18	M10	30	10.5	1					
AEM95-XD0206-D20-M10-L30-Z03-H-F	●	20	3	18	M10	30	10.5	1					
AEM95-XD0206-D25-M12-L35-Z03-H	●	25	3	21	M12	35	12.5	1					
AEM95-XD0206-D25-M12-L35-Z03-H-F	●	25	3	21	M12	35	12.5	1					
AEM95C-XD0310-D35-M16-L43-Z03-H	●	35	3	29	M16	43	17	1.5	XDHW 0310..	3015-M3.5x9	ACK-15	4015-M3.5x11	80-T15
AEM95C-XD0310-D35-M16-L43-Z03-H-F	●	35	3	29	M16	43	17	1.5					
AEM95C-XD0310-D42-M16-L43-Z04-H	●	42	4	29	M16	43	17	1.5					
AEM95C-XD0310-D42-M16-L43-Z04-H-F	●	42	4	29	M16	43	17	1.5					

R: Derecha / Droite / Right L: Izquierda / Gauche / Left

● En Existencia / En stock / In Stock ○ Artículo sin Existencia / Indisponible en Stock / Non Stock Item
 Compatible con el Inserto DJT. / Compatible avec DJT Plaquettes. / Compatible with DJT Insert.

El tamaño del diámetro se produce como - 0,02 mm. F: significa ± 0,02 mm. Por ejemplo: herramienta Ø16 15,98 ± 0,02 mm, significa que debe ser de 16,00 mm - 15,96 mm.

Taille diamètre est produit comme - 0,02 mm. F: des moyens ± 0,02 mm. Par exemple: Ø16 outil 15,98 ± 0,02 mm, cela signifie qu'il devrait être mm 16,00 - 15,96 mm.

Diameter Size is produced as - 0.02 mm. F: means ± 0.02 mm. For example: Ø16 tool 15.98 ± 0.02 mm, it means that it should be 16.00 mm - 15.96 mm.

Ejemplo de Pedido / Exemple de Commande / Ordering Example

1 Piezas / pcs. / pcs. AEM90-3P1004-D20-M10-L35-Z02

Cálculo de Corte : S 369 / Calcul de Coupe : P 369 / Cutting Calculation : 369

Par de Apriete : S 368 / Couple de Serrage : P 368 / Tightening Torque: 368

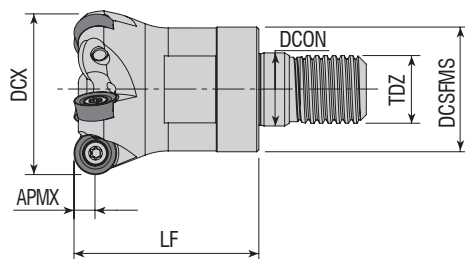

Código del Inserto Le Code de Commande Ordering Code	Stock Stock Stock	Dimension (mm) Dimension (mm) Dimension (mm)							Inserto Plaquette Insert	Recambios / Pièces de Rechange / Spare Parts		
		DCX	ZEFP	DCSFMS	TDZ	LF	DCON	APMX		Tornillo Vis Screw	Llave Torx Clé Torx Torx Wrench	
AEMR-RC10T3-D25-M12-L35-Z03-H	●	25	3	21	M12	35	12.5	5	RC.. 10T3..		80-T15	
AEMR-RC10T3-D32-M16-L43-Z04-H	●	32	4	29	M16	43	17	5				
AEMR-RC10T3-D40-M16-L43-Z05-H	●	40	5	29	M16	43	17	5				

Compatible con el Inserto ZCC. / Compatible avec ZCC Plaquettes. / Compatible with ZCC Insert.

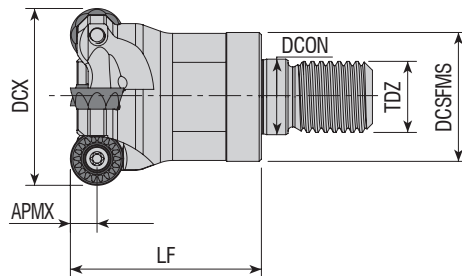

Código del Inserto Le Code de Commande Ordering Code	Stock Stock Stock	Dimension (mm) Dimension (mm) Dimension (mm)							Inserto Plaquette Insert	Recambios / Pièces de Rechange / Spare Parts		
		DCX	ZEFP	DCSFMS	TDZ	LF	DCON	APMX		Tornillo Vis Screw	Llave Torx Clé Torx Torx Wrench	
AEMR-RP08T2M-D20-M10-L30-Z02-H	●	20	2	18	M10	30	10.5	4	RPMT 08T2..	3008-M2.5x6	80-T08	
AEMR-RP10T3M-D25-M12-L35-Z02-H	●	25	2	21	M12	35	12.5	5	RPMT 10T3..	4015-M3.5x9	80-T15	
AEMR-RP10T3M-D32-M16-L43-Z03-H	●	32	3	29	M16	43	17	5	RPMT 1204..	4015-M4x9		
AEMR-RP1204M-D32-M16-L43-Z03-H	●	32	3	29	M16	43	17	6				
AEMR-RP1204M-D40-M16-L43-Z04-H	●	40	4	29	M16	43	17	6				

R: Derecha / Droite / Right L: Izquierda / Gauche / Left

● En Existencia / En stock / In Stock ○ Artículo sin Existencia / Indisponible en Stock / Non Stock Item
 Compatible con el Inserto MTSBH. / Compatible avec MTSBH Plaquettes. / Compatible with MTSBH Insert.

Ejemplo de Pedido / Exemple de Commande / Ordering Example

1 Piezas / pcs. / pcs. AEMR-RC10T3-D25-M12-L35-Z03-H
 Cálculo de Corte : S 369 / Calcul de Coupe : P 369 / Cutting Calculation : 369
 Par de Apriete : S 368 / Couple de Serrage : P 368 / Tightening Torque: 368

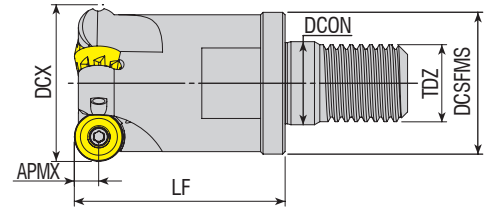

Código del Inserto Le Code de Commande Ordering Code	Stock Stock Stock	Dimension (mm) Dimension (mm) Dimension (mm)							Inserto Plaquette Insert	Recambios / Pièces de Rechange / Spare Parts	
		DCX	ZEFP	DCSFMS	TDZ	LF	DCON	APMX		Tornillo Vis Screw	Llave Torx Clé Torx Torx Wrench
AEMR-RP10T3-D25-M12-L35-Z02-H	●	25	2	21	M12	35	12.5	5	RPNX 10T3..	4010-M3x8	80-T10
AEMR-RP10T3-D32-M16-L43-Z03-H	●	32	3	29	M16	43	17	5			
AEMR-RP1204-D32-M16-L43-Z03-H	●	32	3	29	M16	43	17	6	RPNX 1204..	4015-M4x9	80-T15

Compatible con el Inserto CRTZT. / Compatible avec CRTZT Plaquettes. / Compatible with CRTZT Insert.

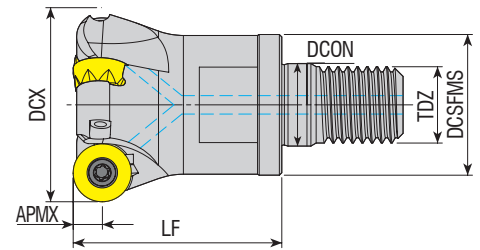

Código del Inserto Le Code de Commande Ordering Code	Stock Stock Stock	Dimension (mm) Dimension (mm) Dimension (mm)							Inserto Plaquette Insert	Recambios / Pièces de Rechange / Spare Parts	
		DCX	ZEFP	DCSFMS	TDZ	LF	DCON	APMX		Tornillo Vis Screw	Llave Torx Clé Torx Torx Wrench
AEMR-RY10-D32-M16-L43-Z04-H	●	32	4	29	M16	43	17	5	RYMX 1004..	4015-M3.5x9	80-T15
AEMR-RY10-D40-M16-L43-Z05-H	●	40	5	29	M16	43	17	5			
AEMR-RY12-D32-M16-L43-Z03-H	●	32	3	29	M16	43	17	6	RYMX 1205..	4015-M4x9	
AEMR-RY12-D40-M16-L43-Z03-H	●	40	3	29	M16	43	17	6			

R: Derecha / Droite / Right L: Izquierda / Gauche / Left

● En Existencia / En stock / In Stock ○ Artículo sin Existencia / Indisponible en Stock / Non Stock Item
 Compatible con el Inserto TGTC. / Compatible avec TGTC Plaquettes. / Compatible with TGTC Insert.

Ejemplo de Pedido / Exemple de Commande / Ordering Example

1 Piezas / pcs. / pcs. AEMR-RP10T3-D25-M12-L35-Z02-H

Cálculo de Corte : S 369 / Calcul de Coupe : P 369 / Cutting Calculation : 369
 Par de Apriete : S 368 / Couple de Serrage : P 368 / Tightening Torque: 368

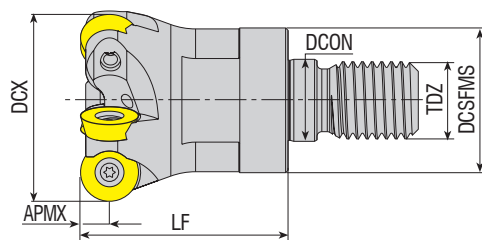

Código del Inserto Le Code de Commande Ordering Code	Stock Stock Stock	Dimension (mm) Dimension (mm) Dimension (mm)							Inserto Plaquette Insert	Recambios / Pièces de Rechange / Spare Parts		
		DCX	ZEPF	DCSFMS	TDZ	LF	DCON	APMX		Tornillo Vis Screw	Llave Torx Clé Torx Torx Wrench	
AEMR-RD0702-D15-M08-L23-Z02-H	●	15	2	13	M08	23	8.5	3.5	RD.. 0702	3008-M2.5x6	80-T08	
AEMR-RD0702-D16-M08-L23-Z02-H	●	16	2	13	M08	23	8.5	3.5				
AEMR-RD0702-D20-M10-L30-Z04-H	●	20	4	18	M10	30	10.5	3.5				
AEMR-RD0702-D25-M12-L35-Z05-H	●	25	5	21	M12	35	12.5	3.5				
AEMR-RD0702-D30-M16-L42-Z05-H	●	30	5	29	M16	42	17	3.5				
AEMR-RD0702-D32-M16-L43-Z05-H	●	32	5	29	M16	43	17	3.5				
AEMR-RD0702-D35-M16-L42-Z06-H	●	35	6	29	M16	42	17	3.5				
AEMR-RD0702-D42-M16-L43-Z05-H	●	42	5	29	M16	43	17	3.5				
AEMR-RD0702-D42-M16-L43-Z07-H	●	42	7	29	M16	43	17	3.5				
AEMR-RD08T2-D16-M08-L23-Z02-H	●	16	2	13	M08	23	8.5	4				RD.. 08T2
AEMR-RD08T2-D16-M10-L23-Z02-H	●	16	2	13	M10	23	8.5	4				
AEMR-RD08T2-D20-M10-L30-Z03-H	●	20	3	18	M10	30	10.5	4				
AEMR-RD08T2-D25-M12-L35-Z04-H	●	25	4	21	M12	35	12.5	4	RD.. 0802	3008-M3x6		
AEMR-RD0802-D16-M08-L23-Z02-H	●	16	2	13	M08	23	8.5	4	RD.. 0803	3008-M3x8		
AEMR-RD0803-D16-M08-L23-Z02-H	●	16	2	13	M08	23	8.5	4				
AEMR-RD0803-D20-M10-L30-Z03-H	●	20	3	18	M10	30	10.5	4				
AEMR-RD0803-D25-M12-L35-Z04-H	●	25	4	21	M12	35	12.5	4				
AEMR-RD1003-D20-M10-L30-Z02-H	●	20	2	18	M10	30	10.5	5	RD.. 1003	4015-M3.5x9		
AEMR-RD1003-D25-M12-L35-Z02-H	●	25	2	21	M12	35	12.5	5				
AEMR-RD1003-D25-M12-L35-Z03-H	●	25	3	21	M12	35	12.5	5				
AEMR-RD1003-D30-M16-L43-Z04-H	●	30	4	29	M16	43	17	5				
AEMR-RD1003-D32-M16-L43-Z04-H	●	32	4	29	M16	43	17	5				
AEMR-RD1003-D35-M16-L43-Z04-H	●	35	4	29	M16	43	17	5				
AEMR-RD1003-D40-M16-L43-Z05-H	●	40	5	29	M16	43	17	5				
AEMR-RD1003-D42-M16-L43-Z05-H	●	42	5	29	M16	43	17	5				
AEMR-RD10T3-D25-M12-L35-Z03-H	●	25	3	21	M12	35	12.5	5	RD.. 10T3	4015-M3.5x9		
AEMR-RD10T3-D32-M16-L45-Z04-H	●	32	4	29	M16	45	17	5				
AEMR-RD1004-D25-M12-L35-Z03-H	●	25	3	21	M12	35	12.5	5	RD.. 1004	4515-M4x8		
AEMR-RD1004-D32-M16-L43-Z04-H	●	32	4	29	M16	43	17	5				
AEMR-RD12T3-D24-M12-L35-Z02-H	●	24	2	21	M12	35	12.5	6	RD.. 12T3	4015-M3.5x9		
AEMR-RD12T3-D25-M12-L35-Z02-H	●	25	2	21	M12	35	12.5	6				
AEMR-RD12T3-D32-M16-L43-Z03-H	●	32	3	29	M16	43	17	6				
AEMR-RD12T3-D35-M16-L43-Z03-H	●	35	3	29	M16	43	17	6				
AEMR-RD12T3-D35-M16-L43-Z04-H	●	35	4	29	M16	43	17	6				
AEMR-RD12T3-D40-M16-L43-Z04-H	●	40	4	29	M16	43	17	6				
AEMR-RD12T3-D42-M16-L43-Z05-H	●	42	5	29	M16	43	17	6				
AEMR-RD1204-D32-M16-L43-Z03-H	●	32	3	29	M16	43	17	6			RD.. 1204	
AEMR-RD1204-D42-M16-L43-Z04-H	●	42	4	29	M16	43	17	6				
AEMR-RD1604-D32-M16-L43-Z02-H	●	32	2	29	M16	43	17	8	RD.. 1604	4015-M4.5x11		
AEMR-RD1604-D40-M16-L43-Z02-H	●	40	2	29	M16	43	17	8				
AEMR-RD1604-D42-M16-L43-Z03-H	●	42	3	29	M16	43	17	8				

R: Derecha / Droite / Right L: Izquierda / Gauche / Left

● En Existencia / En stock / In Stock ○ Artículo sin Existencia / Indisponible en Stock / Non Stock Item
 Compatible con el Inserto ISO. / Compatible avec ISO Plaquettes. / Compatible with ISO Insert.

Ejemplo de Pedido / Exemple de Commande / Ordering Example

1 Piezas / pcs. / pcs. AEMR-RD0702-D15-M08-L23-Z02-H

Cálculo de Corte : S 369 / Calcul de Coupe : P 369 / Cutting Calculation : 369

Par de Apriete : S 368 / Couple de Serrage : P 368 / Tightening Torque: 368



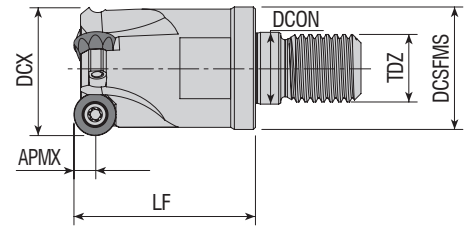

Código del Inserto Le Code de Commande Ordering Code	Stock Stock Stock	Dimension (mm) Dimension (mm) Dimension (mm)							Inserto Plaquette Insert	Recambios / Pièces de Rechange / Spare Parts		
		DCX	ZEFP	DCSFMS	TDZ	LF	DCON	APMX		Tornillo Vis Screw	Llave Torx Clé Torx Torx Wrench	
AEMR-QP10T3-D25-M12-L35-Z02-H	●	25	2	21	M12	35	12.5	5				
AEMR-QP10T3-D32-M16-L43-Z03-H	●	32	3	29	M16	43	17	5				QP. 10T3..

Compatible con el Inserto SMTM. / Compatible avec SMTM Plaquettes. / Compatible with SMTM Insert.

SISTEMA S FRESAS MODULARES DE ALTO AVANCE (TIPO TORNILLO)
 SYSTEM S MODULAIRES (TYPE VIS) FRAISE À EXTRÉMITÉ HAUTE AVANCE
 S-SYSTEM MODULAR (SCREW TYPE) HIGHFEED END MILLS

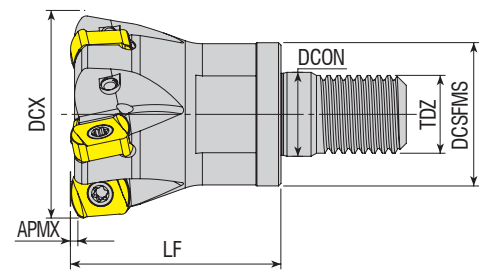

Código del Inserto Le Code de Commande Ordering Code	Stock Stock Stock	Dimension (mm) Dimension (mm) Dimension (mm)							Inserto Plaquette Insert	Recambios / Pièces de Rechange / Spare Parts		
		DCX	ZEFP	DCSFMS	TDZ	LF	DCON	APMX		Tornillo Vis Screw	Llave Torx Clé Torx Torx Wrench	
AHFM-BL0603-D20-M10-L30-Z03-H	●	20	3	18	M10	30	10.5	1				
AHFM-BL0603-D32-M16-L40-Z05-H	●	32	5	29	M16	40	17	1				BLMP 0603..
AHFM-BL0904-D32-M16-L40-Z04-H	●	32	4	29	M16	40	17	1.5	BLMP 0904..	3010-M3.5x9	80-T10	
AHFM-BL0904-D32-M16-L43-Z04-H	●	32	4	29	M16	43	17	1.5				
AHFM-BL0904-D42-M16-L43-Z05-H	●	42	5	29	M16	43	17	1.5				

R: Derecha / Droite / Right L: Izquierda / Gauche / Left

● En Existencia / En stock / In Stock ○ Artículo sin Existencia / Indisponible en Stock / Non Stock Item
 Compatible con el Inserto TGTC. / Compatible avec TGTC Plaquettes. / Compatible with TGTC Insert.



Ejemplo de Pedido / Exemple de Commande / Ordering Example

1 Piezas / pcs. / pcs. AEMR-QP10T3-D25-M12-L35-Z02-H

Cálculo de Corte : S 369 / Calcul de Coupe : P 369 / Cutting Calculation : 369

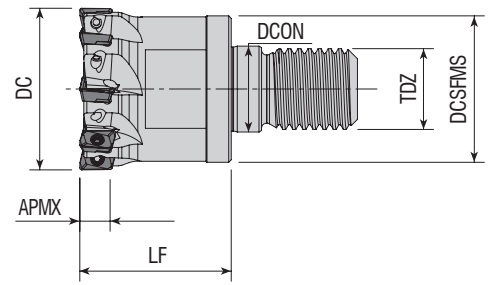

Par de Apriete : S 368 / Couple de Serrage : P 368 / Tightening Torque : 368

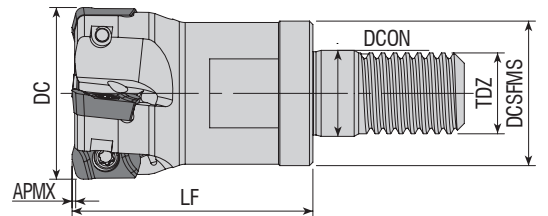

Código del Inserto Le Code de Commande Ordering Code	Stock Stock Stock	Dimension (mm) Dimension (mm) Dimension (mm)							Inserto Plaquette Insert	Recambios / Pièces de Rechange / Spare Parts	
		DC	ZEFP	DCSFMS	TDZ	LF	DCON	APMX		Tornillo Vis Screw	Llave Torx Clé Torx Torx Wrench
AHFM-ED0702-D12-M06-L20-Z03	●	12	3	10	M06	20	6.5	6	 EDMT 0702 JDMT 070204	 3006-M1.8x4	 80-T06
AHFM-ED0702-D16-M08-L25-Z04-H	●	16	4	14.75	M08	25	8.5	6			
AHFM-ED0702-D20-M10-L30-Z05-H	●	20	5	18	M10	30	10.5	6			
AHFM-ED0702-D25-M12-L30-Z06-H	●	25	6	21	M12	30	12.5	6			
AHFM-ED0702-D32-M16-L30-Z08-H	●	32	8	29	M16	30	17	6			

Compatible con el Inserto HTCH. / Compatible avec HTCH Plaquettes. / Compatible with HTCH Insert.



Código del Inserto Le Code de Commande Ordering Code	Stock Stock Stock	Dimension (mm) Dimension (mm) Dimension (mm)							Inserto Plaquette Insert	Recambios / Pièces de Rechange / Spare Parts	
		DC	ZEFP	DCSFMS	TDZ	LF	DCON	APMX		Tornillo Vis Screw	Llave Torx Clé Torx Torx Wrench
AHFM-EP1003-D16-M08-L23-Z02-H	●	16	2	14.75	M08	23	8.5	1	 EP. 1003.. ZPMT 1003.. YPHW 1003..	 3008-M2.5x5	 80-T08
AHFM-EP1003-D20-M10-L30-Z04-H	●	20	4	18	M10	30	10.5	1			
AHFM-EP1003-D25-M12-L35-Z04-H	●	25	4	21	M12	35	12.5	1			
AHFM-EP1003-D32-M16-L43-Z05-H	●	32	5	29	M16	43	17	1			
AHFM-EP1003-D35-M16-L43-Z05-H	●	35	5	29	M16	43	17	1			
AHFM-EP1003-D42-M16-L43-Z06-H	●	42	6	29	M16	43	17	1			

R: Derecha / Droite / Right L: Izquierda / Gauche / Left

● En Existencia / En stock / In Stock ○ Artículo sin Existencia / Indisponible en Stock / Non Stock Item

Compatible con el Inserto DJT. / Compatible avec DJT Plaquettes. / Compatible with DJT Insert.

Ejemplo de Pedido / Exemple de Commande / Ordering Example

1 Piezas / pcs. / pcs. AHFM-ED0702-D12-M06-L20-Z03

Cálculo de Corte : S 369 / Calcul de Coupe : P 369 / Cutting Calculation : 369

Par de Apriete : S 368 / Couple de Serrage : P 368 / Tightening Torque: 368

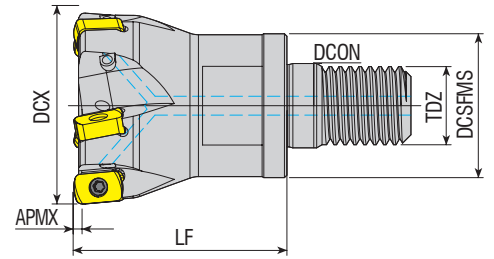

Código del Inserto
 Le Code de Commande
 Ordering Code

Stock Stock Stock	Dimension (mm) Dimension (mm) Dimension (mm)							Inserto Plaquette Insert	Recambios / Pièces de Rechange / Spare Parts			
	DCX	ZEP	DCSFMS	TDZ	LF	DCON	APMX		Tornillo Vis Screw	Abrazadera de Cuñas Mode de Fixation Wedge Clamp	Tornillo de Sujeción Vis de Fixation Wedge Screw	Llave Torx Clé Torx Torx Wrench
●	16	2	14.75	M08	23	8.5	1	ENMU 1004..	3008-M2.5x5			
●	20	3	18	M10	30	10.5	1					
●	25	3	21	M12	35	12.5	1		3008-M2.5x6	-	-	80-T08
●	25	4	21	M12	35	12.5	1					
●	32	5	29	M16	43	17	1					
●	35	5	29	M16	43	17	1					
●	40	5	29	M16	43	17	1					
●	42	5	29	M16	43	17	1					

R: Derecha / Droite / Right L: Izquierda / Gauche / Left

● En Existencia / En stock / In Stock ○ Artículo sin Existencia / Indisponible en Stock / Non Stock Item
 Compatible con el Inserto DJT. / Compatible avec DJT Plaquettes. / Compatible with DJT Insert.

Ejemplo de Pedido / Exemple de Commande / Ordering Example

1 Piezas / pcs. / pcs. AHFM-EN1004-D16-M08-L23-Z02-H

Cálculo de Corte : S 369 / Calcul de Coupe : P 369 / Cutting Calculation : 369

Par de Apriete : S 368 / Couple de Serrage : P 368 / Tightening Torque : 368



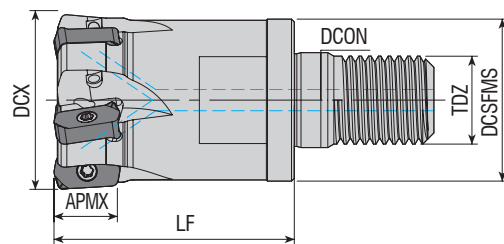

Código del Inserto Le Code de Commande Ordering Code	Stock Stock	Dimension (mm) Dimension (mm) Dimension (mm)						Inserto Plaqueette Insert	Recambios / Pièces de Rechange / Spare Parts				
		DCX	ZEPF	DCSFMS	TDZ	LF	DCON		APMX	Tornillo Vis Screw	Abrazadera de Cuñas Mode de Fixation Wedge Clamp	Tornillo de Sujeción Vis de Fixation Wedge Screw	Llave Torx Clé Torx Torx Wrench
AHFM-LN0303-D25-M12-L35-Z04-H	●	25	4	21	M12	35	12.5	12	LNMU 0303..	3008-M2.5x6	-	-	80-T08
AHFM-LN0303-D32-M16-L43-Z05-H	●	32	5	29	M16	43	17	12					
AHFM-LN0303-D42-M16-L43-Z06-H	●	42	6	29	M16	43	17	12					

Compatible con el Inserto TNGLY. / Compatible avec TNGLY Plaqueettes. / Compatible with TNGLY Insert.

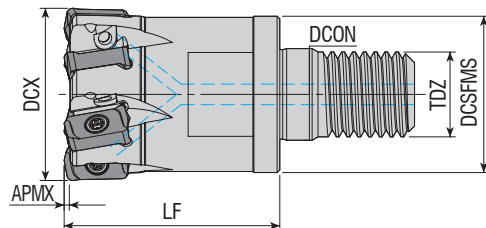

Código del Inserto Le Code de Commande Ordering Code	Stock Stock	Dimension (mm) Dimension (mm) Dimension (mm)						Inserto Plaqueette Insert	Recambios / Pièces de Rechange / Spare Parts				
		DCX	ZEPF	DCSFMS	TDZ	LF	DCON		APMX	Tornillo Vis Screw	Abrazadera de Cuñas Mode de Fixation Wedge Clamp	Tornillo de Sujeción Vis de Fixation Wedge Screw	Llave Torx Clé Torx Torx Wrench
AHFM-L003-D20-M10-L30-Z04-H-F	●	20	4	18	M10	30	10.5	1	LOGU 0303..	1108-M3x6.8	-	-	80-T08
AHFM-L003-D25-M12-L35-Z04-H-F	●	25	4	21	M12	35	12.5	1					
AHFM-L003-D25-M12-L35-Z04-H	●	25	4	21	M12	35	12.5	1					
AHFM-L003-D32-M16-L40-Z05-H-F	●	32	5	29	M16	40	17	1					
AHFM-L003-D32-M16-L40-Z05-H	●	32	5	29	M16	40	17	1					
AHFM-L003-D32-M16-L40-Z06-H-F	●	32	6	29	M16	40	17	1					
AHFM-L003-D32-M16-L40-Z06-H	●	32	6	29	M16	40	17	1					
AHFM-L003-D35-M16-L40-Z05-H	●	35	5	29	M16	40	17	1					
AHFM-L003-D35-M16-L40-Z06-H	●	35	6	29	M16	40	17	1					
AHFM-L003-D42-M16-L40-Z05-H	●	42	5	29	M16	40	17	1					
AHFM-L003-D42-M16-L40-Z06-H	●	42	6	29	M16	40	17	1					

R: Derecha / Droite / Right L: Izquierda / Gauche / Left

● En Existencia / En stock / In Stock ○ Artículo sin Existencia / Indisponible en Stock / Non Stock Item

Compatible con el Inserto KYCR. / Compatible avec KYCR Plaqueettes. / Compatible with KYCR Insert.

F: El valor de descentramiento axial y radial está dentro de 0,02 mm. / F: Axiale et radiale Runout valeur est dans 0,02 mm.

F: Axial and Radial Runout Value is within 0,02 mm.

Ejemplo de Pedido / Exemple de Commande / Ordering Example

1 Piezas / pcs. / pcs. AHFM-LN0303-D25-M12-L35-Z04-H

Cálculo de Corte : S 369 / Calcul de Coupe : P 369 / Cutting Calculation : 369

Par de Apriete : S 368 / Couple de Serrage : P 368 / Tightening Torque: 368

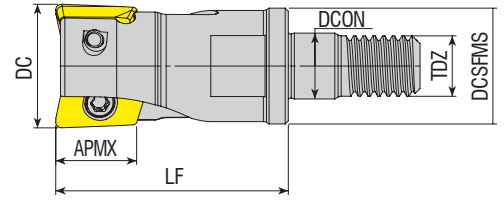
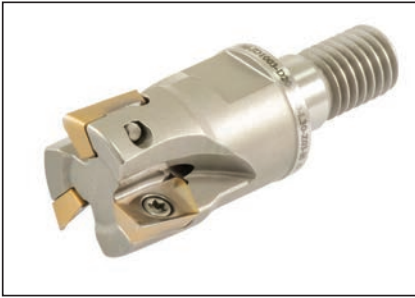

Código del Inserto Le Code de Commande Ordering Code	Stock Stock Stock	Dimension (mm) Dimension (mm) Dimension (mm)							Inserto Plaqueette Insert	Recambios / Pièces de Rechange / Spare Parts		
		DC	ZEFP	DCSFMS	TDZ	LF	DCON	APMX		Tornillo Vis Screw	Llave Torx Clé Torx Torx Wrench	
AHFM-JD1003-D16-M08-L30-Z02-H	●	16	2	14.75	M08	30	8.5	9				
AHFM-JD1003-D20-M10-L30-Z03-H	●	20	3	18	M10	30	10.5	9				JDMT 1003..

Compatible con el Inserto HTCH. / Compatible avec HTCH Plaquettes. / Compatible with HTCH Insert.

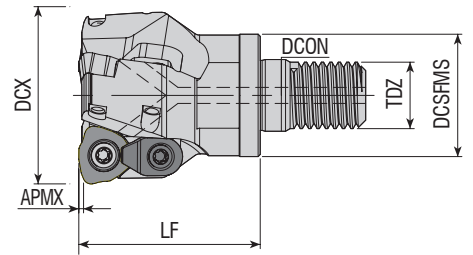

Código del Inserto Le Code de Commande Ordering Code	Stock Stock Stock	Dimension (mm) Dimension (mm) Dimension (mm)							Inserto Plaqueette Insert	Recambios / Pièces de Rechange / Spare Parts			
		DCX	ZEFP	DCSFMS	TDZ	LF	DCON	APMX		Tornillo Vis Screw	Abrazadera de Cuiñas Mode de Fixation Wedge Clamp	Tornillo de Sujeción Vis de Fixation Wedge Screw	Llave Torx Clé Torx Torx Wrench
AHFMC-JD1204-D32-M16-L43-Z02-H	●	32	2	29	M16	43	17	1.5					
AHFMC-JD1204-D42-M16-L43-Z03-H	●	42	3	29	M16	43	17	1.5					

R: Derecha / Droite / Right L: Izquierda / Gauche / Left

● En Existencia / En stock / In Stock ○ Artículo sin Existencia / Indisponible en Stock / Non Stock Item

Compatible con el Inserto MTSBH. / Compatible avec MTSBH Plaquettes. / Compatible with MTSBH Insert.

Ejemplo de Pedido / Exemple de Commande / Ordering Example

1 Piezas / pcs. / pcs. AHFM-JD1003-D16-M08-L30-Z02-H

Cálculo de Corte : S 369 / Calcul de Coupe : P 369 / Cutting Calculation : 369

Par de Apriete : S 368 / Couple de Serrage : P 368 / Tightening Torque: 368

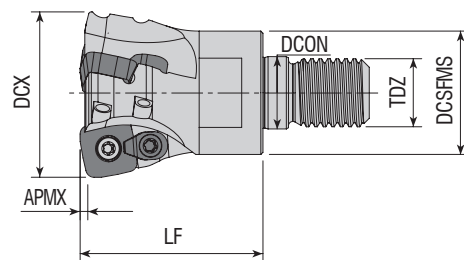

Código del Inserto Le Code de Commande Ordering Code	Stock Stock Stock	Dimension (mm) Dimension (mm) Dimension (mm)						Inserto Plaquette Insert	Recambios / Pièces de Rechange / Spare Parts				
		DCX	ZEPF	DCSFMS	TDZ	LF	DCON		APMX	Tornillo Vis Screw	Abrazadera de Cuñas Mode de Fixation Wedge Clamp	Tornillo de Sujeción Vis de Fixation Wedge Screw	Llave Torx Clé Torx Torx Wrench
AHFM-SD06T2-D16-M08-L23-Z02-H	●	16	2	14.75	M08	23	8.5	0.8			-	-	
AHFM-SD06T2-D20-M10-L30-Z03-H	●	20	3	18	M10	30	10.5	0.8	SD.. 06T2..	3007-M2.2x5	-	-	80-T07
AHFM-SD06T2-D25-M12-L35-Z04-H	●	25	4	21	M12	35	12.5	0.8					
AHFMC-SD09T3-D25-M12-L30-Z02-H	●	25	2	22	M12	30	12.5	1.4					
AHFMC-SD09T3-D32-M16-L43-Z03-H	●	32	3	29	M16	43	17	1.4	SD.. 09T3..	3010-M3.5x9	ACK-15	1510-M3.5x9	80-T10
AHFMC-SD09T3-D35-M16-L43-Z03-H	●	35	3	29	M16	43	17	1.4					
AHFMC-SD09T3-D40-M16-L43-Z04-H	●	40	4	29	M16	43	17	1.4					
AHFMC-SD1204-D32-M16-L43-Z02-H	●	32	2	29	M16	43	17	1.8	SD.. 1204..	4015-M4x9		4015-M3.5X11	80-T15
AHFMC-SD1204-D40-M16-L43-Z03-H	●	40	3	29	M16	43	17	1.8					

Compatible con el Inserto ZCC. / Compatible avec ZCC Plaquettes. / Compatible with ZCC Insert.

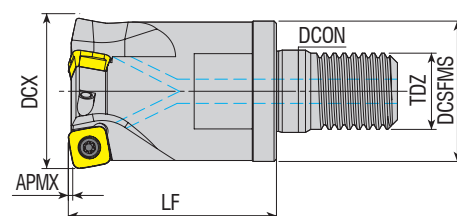

Código del Inserto Le Code de Commande Ordering Code	Stock Stock Stock	Dimension (mm) Dimension (mm) Dimension (mm)						Inserto Plaquette Insert	Recambios / Pièces de Rechange / Spare Parts				
		DCX	ZEPF	DCSFMS	TDZ	LF	DCON		APMX	Tornillo Vis Screw	Abrazadera de Cuñas Mode de Fixation Wedge Clamp	Tornillo de Sujeción Vis de Fixation Wedge Screw	Llave Torx Clé Torx Torx Wrench
AHFM-S00803-D20-M10-L30-Z02-H	●	20	2	18	M10	30	10.5	1					
AHFM-S00803-D25-M12-L35-Z03-H	●	25	3	22	M12	35	12.5	1					
AHFM-S00803-D32-M16-L43-Z03-H	●	32	3	29	M16	43	17	1	SOMW 0803..	4010-M3X8	-	-	80-T10
AHFM-S00803-D32-M16-L43-Z04-H	●	32	4	29	M16	43	17	1					
AHFM-S00803-D40-M16-L43-Z04-H	●	40	4	29	M16	43	17	1					

R: Derecha / Droite / Right L: Izquierda / Gauche / Left

● En Existencia / En stock / In Stock ○ Artículo sin Existencia / Indisponible en Stock / Non Stock Item
 Compatible con el Inserto KPTK. / Compatible avec KPTK Plaquettes. / Compatible with KPTK Insert.

Ejemplo de Pedido / Exemple de Commande / Ordering Example

1 Piezas / pcs. / pcs. AHFM-SD06T2-D16-M08-L23-Z02-H
 Cálculo de Corte : S 369 / Calcul de Coupe : P 369 / Cutting Calculation : 369
 Par de Apriete : S 368 / Couple de Serrage : P 368 / Tightening Torque: 368

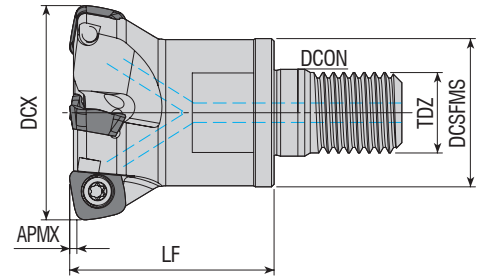

Código del Inserto Le Code de Commande Ordering Code	Stock Stock	Dimension (mm) Dimension (mm) Dimension (mm)						Inserto Plaquette Insert	Recambios / Pièces de Rechange / Spare Parts				
		DCX	ZEFP	DCSFMS	TDZ	LF	DCON		APMX	Tornillo Vis Screw	Abrazadera de Cuñas Mode de Fixation Wedge Clamp	Tornillo de Sujeción Vis de Fixation Wedge Screw	Llave Torx Clé Torx Torx Wrench
AHFM-SO1004-D32-M16-L40-Z03-H	●	32	3	29	M16	40	17	1.5	SOMT 1004..	4015-M4x9	-	-	80-T15
AHFM-SO1004-D40-M16-L40-Z04-H	●	40	4	29	M16	40	17	1.5					
AHFM-SO1004-D42-M16-L40-Z04-H	●	42	4	29	M16	40	17	1.5					

Compatible con el Inserto KYCR. / Compatible avec KYCR Plaquettes. / Compatible with KYCR Insert.

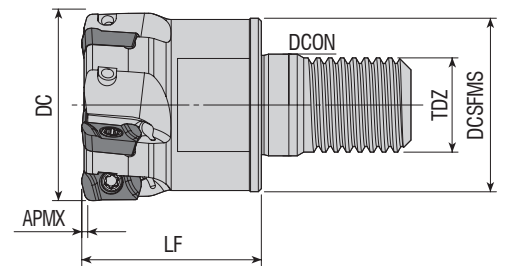

Código del Inserto Le Code de Commande Ordering Code	Stock Stock	Dimension (mm) Dimension (mm) Dimension (mm)						Inserto Plaquette Insert	Recambios / Pièces de Rechange / Spare Parts				
		DC	ZEFP	DCSFMS	TDZ	LF	DCON		APMX	Tornillo Vis Screw	Abrazadera de Cuñas Mode de Fixation Wedge Clamp	Tornillo de Sujeción Vis de Fixation Wedge Screw	Llave Torx Clé Torx Torx Wrench
AHFM-YP1003-D16-M08-L23-Z02-F	●	16	2	14.75	M08	23	8.5	1	EP. 1003.. ZPMT 1003.. YPHW 1003..	3008-M2.5x5	-	-	80-T08
AHFM-YP1003-D16-M08-L23-Z02-H-F	●	16	2	14.75	M08	23	8.5	1					
AHFM-YP1003-D17-M08-L23-Z02-H	●	17	2	14.75	M08	23	8.5	1					
AHFM-YP1003-D17-M08-L23-Z02-H-F	●	17	2	14.75	M08	23	8.5	1					
AHFM-YP1003-D20-M10-L30-Z03-H	●	20	3	18	M10	30	10.5	1					
AHFM-YP1003-D20-M10-L30-Z03-H-F	●	20	3	18	M10	30	10.5	1					
AHFM-YP1003-D20-M10-L30-Z04-H	●	20	4	18	M10	30	10.5	1					
AHFM-YP1003-D20-M10-L30-Z04-F	●	20	4	18	M10	30	10.5	1					
AHFM-YP1003-D21-M10-L30-Z03-H	●	21	3	18	M10	30	10.5	1					
AHFM-YP1003-D21-M10-L30-Z03-H-F	●	21	3	18	M10	30	10.5	1					
AHFM-YP1003-D25-M12-L35-Z04-H	●	25	4	21	M12	35	12.5	1					
AHFM-YP1003-D25-M12-L35-Z04-F	●	25	4	21	M12	35	12.5	1					
AHFM-YP1003-D25-M12-L35-Z04-H-F	●	25	4	21	M12	35	12.5	1					
AHFM-YP1003-D26-M12-L35-Z04-H-F	●	26	4	21	M12	35	12.5	1					
AHFM-YP1003-D32-M16-L30-Z05-F	●	32	5	29	M16	30	17	1					
AHFM-YP1003-D32-M16-L43-Z05-H-F	●	32	5	29	M16	43	17	1					
AHFM-YP1003-D40-M16-L43-Z06-H-F	●	40	6	29	M16	43	17	1					
AHFM-YP1003-D42-M16-L43-Z06-H-F	●	42	6	29	M16	43	17	1					

R: Derecha / Droite / Right L: Izquierda / Gauche / Left

● En Existencia / En stock / In Stock ○ Artículo sin Existencia / Indisponible en Stock / Non Stock Item
 Compatible con el Inserto DJT. / Compatible avec DJT Plaquettes. / Compatible with DJT Insert.

El tamaño del diámetro se produce como - 0,02 mm. F: significa ± 0,02 mm. Por ejemplo: herramienta Ø16 15,98 ± 0,02 mm, significa que debe ser de 16,00 mm - 15,96 mm.

Taille diamètre est produit comme - 0,02 mm. F: des moyens ± 0,02 mm. Par exemple: Ø16 outil 15,98 ± 0,02 mm, cela signifie qu'il devrait être mm 16,00 - 15,96 mm.

Diameter Size is produced as - 0.02 mm. F: means ± 0.02 mm. For example: Ø16 tool 15.98 ± 0.02 mm, it means that it should be 16.00 mm - 15.96 mm.

Ejemplo de Pedido / Exemple de Commande / Ordering Example

1 Piezas / pcs. / pcs. AHFM-SO1004-D32-M16-L40-Z03-H

Cálculo de Corte : S 369 / Calcul de Coupe : P 369 / Cutting Calculation : 369

Par de Apriete : S 368 / Couple de Serrage : P 368 / Tightening Torque: 368

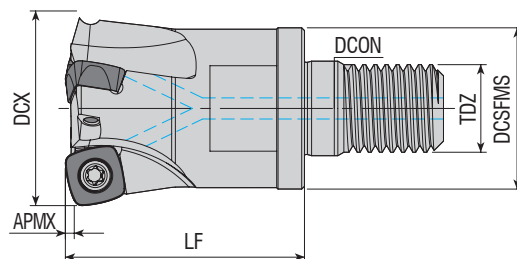

Código del Inserto Le Code de Commande Ordering Code	Stock Stock Stock	Dimension (mm) Dimension (mm) Dimension (mm)						Inserto Plaquette Insert	Recambios / Pièces de Rechange / Spare Parts				
		DCX	ZEP	DCSFMS	TDZ	LF	DCON		APMX	Tornillo Vis Screw	Abrazadera de Cuñas Mode de Fixation Wedge Clamp	Tornillo de Sujeción Vis de Fixation Wedge Screw	Llave Torx Clé Torx Torx Wrench
AHFM-SP1004-D25-M12-L35-Z02-H	●	25	2	21	M12	35	12.5	1	SPNW 1004..	3015-M3.5x9	-	-	80-T15
AHFM-SP1004-D32-M16-L43-Z03-H	●	32	3	29	M16	43	17	1.5					
AHFM-SP1004-D35-M16-L43-Z03-H	●	35	3	29	M16	43	17	1.5					
AHFM-SP1004-D42-M16-L43-Z04-H	●	42	4	29	M16	43	17	1.5					

Compatible con el Inserto DJT. / Compatible avec DJT Plaquettes. / Compatible with DJT Insert.

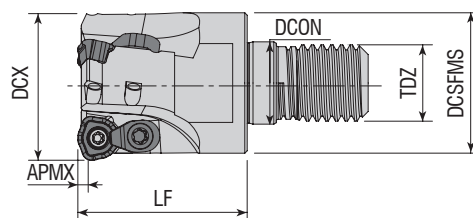

Código del Inserto Le Code de Commande Ordering Code	Stock Stock Stock	Dimension (mm) Dimension (mm) Dimension (mm)						Inserto Plaquette Insert	Recambios / Pièces de Rechange / Spare Parts				
		DCX	ZEP	DCSFMS	TDZ	LF	DCON		APMX	Tornillo Vis Screw	Abrazadera de Cuñas Mode de Fixation Wedge Clamp	Tornillo de Sujeción Vis de Fixation Wedge Screw	Llave Torx Clé Torx Torx Wrench
AHFMC-WD0804-D25-M12-L35-Z02-H	●	25	2	21	M12	35	12.5	1.5	WDMT 0804..	4010-M3x8	ACK-15	4010-M3x8	80-T10
AHFMC-WD0804-D32-M16-L35-Z03-H	●	32	3	29	M16	35	17	1.5					

R: Derecha / Droite / Right L: Izquierda / Gauche / Left

● En Existencia / En stock / In Stock ○ Artículo sin Existencia / Indisponible en Stock / Non Stock Item
Compatible con el Inserto SMTM. / Compatible avec SMTM Plaquettes. / Compatible with SMTM Insert.

Ejemplo de Pedido / Exemple de Commande / Ordering Example

1 Piezas / pcs. / pcs. AHFM-SP1004-D25-M12-L35-Z02-H
Cálculo de Corte : S 369 / Calcul de Coupe : P 369 / Cutting Calculation : 369
Par de Apriete : S 368 / Couple de Serrage : P 368 / Tightening Torque: 368

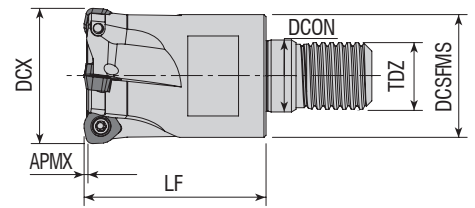

Código del Inserto Le Code de Commande Ordering Code	Stock Stock Stock	Dimension (mm) Dimension (mm) Dimension (mm)							Inserto Plaquette Insert	Recambios / Pièces de Rechange / Spare Parts				
		DCX	ZEFP	DCSFMS	TDZ	LF	DCON	APMX		Tornillo Vis Screw	Abrazadera de Cuiñas Mode de Fixation Wedge Clamp	Tornillo de Sujeción Vis de Fixation Wedge Screw	Llave Torx Clé Torx Torx Wrench	
AHFM-WD0503D-D20-M10-L30-Z02-H	●	20	2	18	M10	30	10.5	1.25		4010-M3x6				
AHFM-WD0503D-D25-M12-L35-Z03-H	●	25	3	21	M12	35	12.5	1.25		4010-M3x8	-	-	80-T10	
AHFM-WD0503D-D32-M16-L43-Z04-H	●	32	4	29	M16	43	17	1.25						
AHFM-WD0503D-D40-M16-L43-Z05-H	●	40	5	29	M16	43	17	1.25						
AHFMC-WD06T3D-D35-M16-L43-Z03-H	●	35	3	29	M16	43	17	1.5	WDHW 06T3..	3015-M3.5x9	ACK-15	4015-M3.5x11	80-T15	
AHFMC-WD0805D-D32-M16-L43-Z02-H	●	32	2	29	M16	43	17	2	WDHW 0805..	4020-M4.5x10	ACK-19	4020-M4.5x12		

Compatible con el Inserto DJT. / Compatible avec DJT Plaquettes. / Compatible with DJT Insert.

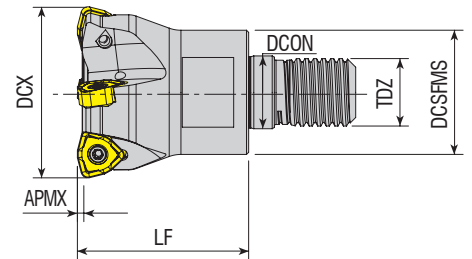

Código del Inserto Le Code de Commande Ordering Code	Stock Stock Stock	Dimension (mm) Dimension (mm) Dimension (mm)							Inserto Plaquette Insert	Recambios / Pièces de Rechange / Spare Parts		
		DCX	ZEFP	DCSFMS	TDZ	LF	DCON	APMX		Tornillo Vis Screw	Llave Torx Clé Torx Torx Wrench	
AHFM-WN09T3-D32-M16-L40-Z03-H	●	32	3	29	M16	40	17	1.5		4010-M3x8	80-T10	
AHFM-WN09T3-D40-M16-L40-Z04-H	●	40	4	29	M16	40	17	1.5				

R: Derecha / Droite / Right L: Izquierda / Gauche / Left

● En Existencia / En stock / In Stock ○ Artículo sin Existencia / Indisponible en Stock / Non Stock Item
 Compatible con el Inserto KRLY. / Compatible avec KRLY Plaquettes. / Compatible with KRLY Insert.

Ejemplo de Pedido / Exemple de Commande / Ordering Example

1 Piezas / pcs. / pcs. AHFM-WD0503D-D20-M10-L30-Z02-H

Cálculo de Corte : S 369 / Calcul de Coupe : P 369 / Cutting Calculation : 369

Par de Apriete : S 368 / Couple de Serrage : P 368 / Tightening Torque : 368

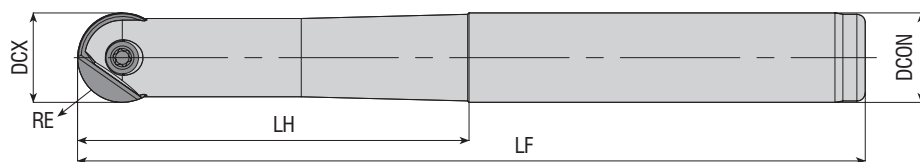

Código del Inserto Le Code de Commande Ordering Code	Stock Stock Stock	Dimension (mm) Dimension (mm) Dimension (mm)					Inserto Plaquette Insert	Recambios / Pièces de Rechange / Spare Parts	
		DCX	RE	DCON	LF	LH		Tornillo Vis Screw	Llave Torx Clé Torx Torx Wrench
APMR-BNM12-D12-C12-L130	●	12	6	12	130	32			
APMR-BNM16-D16-C16-L175	●	16	8	16	175	70			
APMR-BNM16-D16-C16-L200	●	16	8	16	200	100			
APMR-BNM20-D20-C20-L160	●	20	10	20	160	70			
APMR-BNM20-D20-C20-L200	●	20	10	20	200	100			
APMR-BNM20-D20-C20-L250	●	20	10	20	250	150			
APMR-BNM25-D25-C25-L160	●	25	12.5	25	160	70			
APMR-BNM25-D25-C25-L200	●	25	12.5	25	200	100			
APMR-BNM25-D25-C25-L250	●	25	12.5	25	250	150			

Compatible con el Inserto DJT. / Compatible avec DJT Plaquettes. / Compatible with DJT Insert.

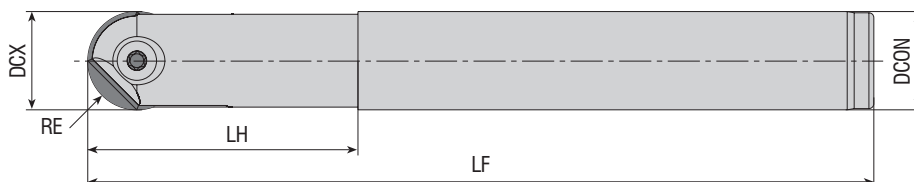

Código del Inserto Le Code de Commande Ordering Code	Stock Stock Stock	Dimension (mm) Dimension (mm) Dimension (mm)					Inserto Plaquette Insert	Recambios / Pièces de Rechange / Spare Parts	
		DCX	RE	DCON	LF	LH		Tornillo Vis Screw	Llave Torx Clé Torx Torx Wrench
APMR-RO12-D12-C12-L120	●	12	6	12	120	35			
APMR-RO12-D12-C16-L160	●	12	6	16	160	50			
APMR-RO16-D16-C16-L160	●	16	8	16	160	45			
APMR-RO16-D16-C16-L200	●	16	8	16	200	45			
APMR-RO16-D16-C20-L200	●	16	8	20	200	65			
APMR-RO20-D20-C20-L160	●	20	10	20	160	55			
APMR-RO20-D20-C20-L200	●	20	10	20	200	55			
APMR-RO20-D20-C25-L220	●	20	10	25	220	80			

R: Derecha / Droite / Right L: Izquierda / Gauche / Left

● En Existencia / En stock / In Stock ○ Artículo sin Existencia / Indisponible en Stock / Non Stock Item
Compatible con el Inserto ZCC. / Compatible avec ZCC Plaquettes. / Compatible with ZCC Insert.

Ejemplo de Pedido / Exemple de Commande / Ordering Example

1 Piezas / pcs. / pcs. APMR-BNM12-D12-C12-L130

Cálculo de Corte : S 369 / Calcul de Coupe : P 369 / Cutting Calculation : 369

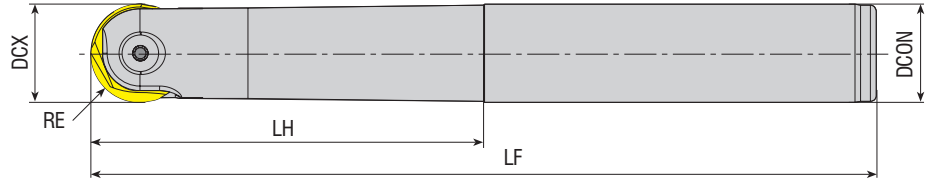

Código del Inserto Le Code de Commande Ordering Code	Stock Stock Stock	Dimension (mm) Dimension (mm) Dimension (mm)					Inserto Plaquette Insert	Recambios / Pièces de Rechange / Spare Parts		
		DCX	RE	DCON	LF	LH		Tornillo Vis Screw	Llave Torx Clé Torx Torx Wrench	Llaves Allen Clés Allen Allen Wrench
APMR-P3208-D08-C10-L110	●	8	4	10	110	25				
APMR-P3210-D10-C10-L130	●	10	5	10	130	30				
APMR-P3210-D10-C12-L130	●	10	5	12	130	30				
APMR-P3212-D12-C12-L130	●	12	6	12	130	32				
APMR-P3216-D16-C16-L175	●	16	8	16	175	75				
APMR-P3220-D20-C20-L200	●	20	10	20	200	100				
APMR-P3225-D25-C25-L200	●	25	12.5	25	200	100				
APMR-P3232-D32-C32-L200	●	32	16	32	200	100				

Compatible con el Inserto WLTR. / Compatible avec WLTR Plaquettes. / Compatible with WLTR Insert.

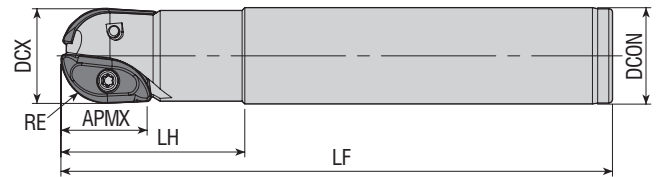

Código del Inserto Le Code de Commande Ordering Code	Stock Stock Stock	Dimension (mm) Dimension (mm) Dimension (mm)						Inserto Plaquette Insert	Recambios / Pièces de Rechange / Spare Parts		
		DCX	RE	DCON	LF	LH	APMX		Tornillo Vis Screw	Llave Torx Clé Torx Torx Wrench	Llaves Allen Clés Allen Allen Wrench
APMR-XP16-D16-C16-L150	●	16	8	16	150	40	16				
APMR-XP20-D20-C20-L150	●	20	10	20	150	50	20				
APMR-XP25-D25-C25-L150	●	25	12.5	25	150	50	25				

R: Derecha / Droite / Right L: Izquierda / Gauche / Left

● En Existencia / En stock / In Stock ○ Artículo sin Existencia / Indisponible en Stock / Non Stock Item
Compatible con el Inserto ZCC. / Compatible avec ZCC Plaquettes. / Compatible with ZCC Insert.

Ejemplo de Pedido / Exemple de Commande / Ordering Example

1 Piezas / pcs. / pcs. APMR-P3208-D08-C10-L110

Cálculo de Corte : S 369 / Calcul de Coupe : P 369 / Cutting Calculation : 369

MOLINOS DE EXTREMO MODULAR DE BOLA (TIPO TORNILLO)
FRAISE À RAINURER MODULAIRE (TYPE VIS)
BALL NOSE MODULAR (SCREW TYPE) END MILLS

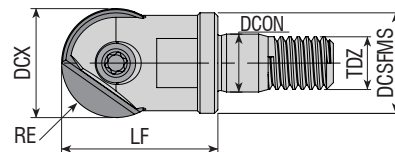

Código del Inserto Le Code de Commande Ordering Code	Stock Stock Stock	Dimension (mm) Dimension (mm) Dimension (mm)						Inserto Plaquette Insert	Recambios / Pièces de Rechange / Spare Parts		
		DCX	RE	DCSFMS	TDZ	LF	DCON		Tornillo Vis Screw	Llave Torx Clé Torx Torx Wrench	
APMR-BNM12-D12-M06-L20	●	12	6	11	M06	20	6.5				
APMR-BNM16-D16-M08-L23	●	16	8	14.75	M08	23	8.5				
APMR-BNM20-D20-M10-L30	●	20	10	18	M10	30	10.5				

Compatible con el Inserto DJT. / Compatible avec DJT Plaquettes. / Compatible with DJT Insert.

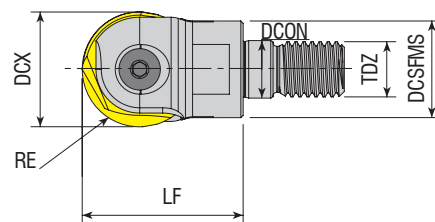

Código del Inserto Le Code de Commande Ordering Code	Stock Stock Stock	Dimension (mm) Dimension (mm) Dimension (mm)						Inserto Plaquette Insert	Recambios / Pièces de Rechange / Spare Parts		
		DCX	RE	DCSFMS	TDZ	LF	DCON		Tornillo Vis Screw	Llave Torx Clé Torx Torx Wrench	
APMR-P3216-D16-M08-L25	●	16	8	14	M08	25	8.5				
APMR-P3220-D20-M10-L30	●	20	10	18	M10	30	10.5				
APMR-P3225-D25-M12-L35	●	25	12.5	21	M12	35	12.5				
APMR-P3232-D32-M16-L43	●	32	16	30	M16	43	17				

R: Derecha / Droite / Right L: Izquierda / Gauche / Left

● En Existencia / En stock / In Stock ○ Artículo sin Existencia / Indisponible en Stock / Non Stock Item
 Compatible con el Inserto WLTR. / Compatible avec WLTR Plaquettes. / Compatible with WLTR Insert.

Ejemplo de Pedido / Exemple de Commande / Ordering Example

1 Piezas / pcs. / pcs. APMR-BNM12-D12-M06-L20

Cálculo de Corte : S 369 / Calcul de Coupe : P 369 / Cutting Calculation : 369

Par de Apriete : S 368 / Couple de Serrage : P 368 / Tightening Torque: 368



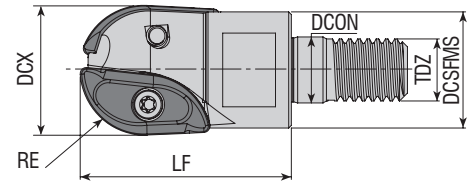

Código del Inserto Le Code de Commande Ordering Code	Stock Stock	Dimension (mm) Dimension (mm) Dimension (mm)						Inserto Plaquette Insert	Recambios / Pièces de Rechange / Spare Parts			
		DCX	RE	DCSFMS	TDZ	LF	DCON		Tornillo Vis Screw	Llave Torx Clé Torx Torx Wrench		
APMR-SWB225-D25-M12-L35	●	25	12.5	23.5	M12	35	12.5					
APMR-SWB230-D30-M16-L43	●	30	15	28	M16	43	17					
APMR-SWB232-D32-M16-L43	●	32	16	30	M16	43	17					

Compatible con el Inserto DJT. / Compatible avec DJT Plaquettes. / Compatible with DJT Insert.

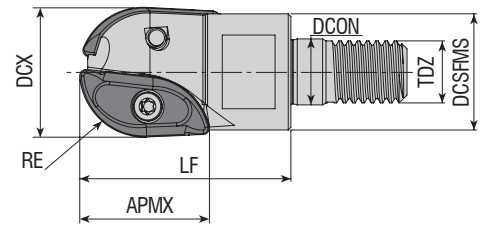

Código del Inserto Le Code de Commande Ordering Code	Stock Stock	Dimension (mm) Dimension (mm) Dimension (mm)							Inserto Plaquette Insert	Recambios / Pièces de Rechange / Spare Parts			
		DCX	RE	DCSFMS	TDZ	LF	APMX	DCON		Tornillo Vis Screw	Llave Torx Clé Torx Torx Wrench		
APMR-XP16-D16-M08-L25	●	16	8	14.75	M08	25	16	8.5					
APMR-XP20-D20-M10-L30	●	20	10	18	M10	30	20	10.5					
APMR-XP25-D25-M12-L40	●	25	12.5	22	M12	40	25	12.5					

R: Derecha / Droite / Right L: Izquierda / Gauche / Left

● En Existencia / En stock / In Stock ○ Artículo sin Existencia / Indisponible en Stock / Non Stock Item
 Compatible con el Inserto ZCC. / Compatible avec ZCC Plaquettes. / Compatible with ZCC Insert.

Ejemplo de Pedido / Exemple de Commande / Ordering Example

1 Piezas / pcs. / pcs. APMR-SWB225-D25-M12-L35

Cálculo de Corte : S 369 / Calcul de Coupe : P 369 / Cutting Calculation : 369

Par de Apriete : S 368 / Couple de Serrage : P 368 / Tightening Torque: 368

PORTA HERRAMIENTAS DE TORNILLO
PORTE-OUTILS A VIS
SCREWED TOOL HOLDERS

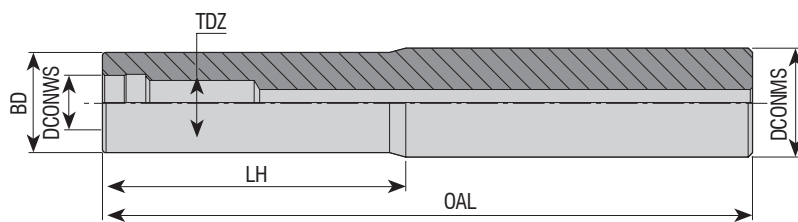

Código del Inserto Le Code de Commande Ordering Code	Stock Stock Stock	Dimension (mm) Dimension (mm) Dimension (mm)					
		DCONMS	TDZ	DCONWS	BD	OAL	LH
AVTT-D13-C16-M08-L100-H	●	16	M08	8.5	13	100	40
AVTT-D15-C16-M08-L130-H	●	16	M08	8.5	15	130	70
AVTT-D18-C20-M10-L130-H	●	20	M10	10.5	18	130	70
AVTT-D18-C20-M10-L160-H	●	20	M10	10.5	18	160	80
AVTT-D23-C25-M12-L150-H	●	25	M12	12.5	23	150	70
AVTT-D23-C25-M12-L200-H	●	25	M12	12.5	23	200	100
AVTT-D23-C25-M12-L250-H	●	25	M12	12.5	23	250	150
AVTT-D30-C32-M16-L150-H	●	32	M16	17	30	150	70
AVTT-D30-C32-M16-L200-H	●	32	M16	17	30	200	100
AVTT-D30-C32-M16-L250-H	●	32	M16	17	30	250	150
AVTT-D30-C32-M16-L300-H	●	32	M16	17	30	300	200

HERRAMIENTA DE FRESADO ROSCADO
OUTILS À FILETER
THREAD MILLING TOOLS

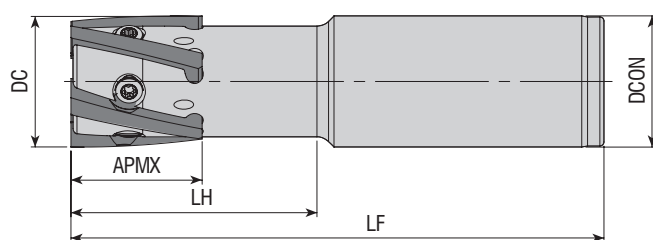

Código del Inserto Le Code de Commande Ordering Code	Stock Stock Stock	Dimension (mm) Dimension (mm) Dimension (mm)						Inserto Plaquette Insert	Recambios / Pièces de Rechange / Spare Parts	
		DC	ZEFP	DCON	LF	LH	APMX		Tornillo Vis Screw	Llave Torx Clé Torx Torx Wrench
ATM-H23-D23-C25-L100-Z02-H	●	23	2	25	100	30	27			
ATM-H32-D32-C32-L130-Z05-H	●	32	5	32	130	35	32			

R: Derecha / Droite / Right L: Izquierda / Gauche / Left

● En Existencia / En stock / In Stock ○ Artículo sin Existencia / Indisponible en Stock / Non Stock Item
Compatible con el Inserto CPT / Compatible avec CPT Plaquettes. / Compatible with CPT Insert.

Ejemplo de Pedido / Exemple de Commande / Ordering Example

1 Piezas / pcs. / pcs. AVTT-D13-C16-M08-L100-H

Cálculo de Corte : S 369 / Calcul de Coupe : P 369 / Cutting Calculation : 369

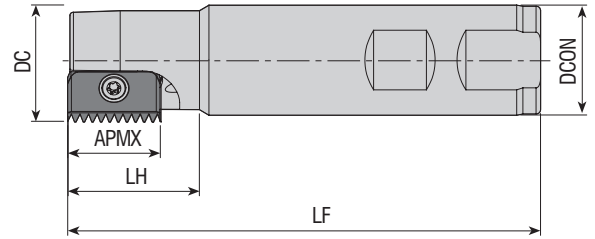

Código del Inserto Le Code de Commande Ordering Code	Stock Stock Stock	Dimension (mm) Dimension (mm) Dimension (mm)						Inserto Plaquette Insert	Recambios / Pièces de Rechange / Spare Parts	
		DC	ZEFP	DCON	LF	LH	APMX		Tornillo Vis Screw	Llave Torx Clé Torx Torx Wrench
ATM-C14-D14-W20-L100-Z01-H	●	14	1	20	100	25	14	C14	3008-M2.5x6	80-T08
ATM-C21-D18-W20-L100-Z01-H	●	18	1	20	100	30	21		4015-M4x9	
ATM-C21-D21-W25-L125-Z01-H	●	21	1	25	125	40	21		4015-M4x11	
ATM-C21-D25-W20-L125-Z01-H	●	25	1	20	125	30	21			
ATM-C21-D28-W25-L90-Z01-H	●	28	1	25	90	30	21			
ATM-C21-D38-W32-L90-Z03-H	●	38	3	32	90	30	21			
ATM-C21-D38-W32-L120-Z03-H	●	38	3	32	120	30	21			
ATM-C21-D43-W32-L90-Z03-H	●	43	3	32	90	30	21	C30	1020-M5x14	80-T20
ATM-C30-D29-W25-L150-Z01-H	●	29	1	25	150	50	30			

Compatible con el Inserto CPT. / Compatible avec CPT Plaquettes. / Compatible with CPT Insert.

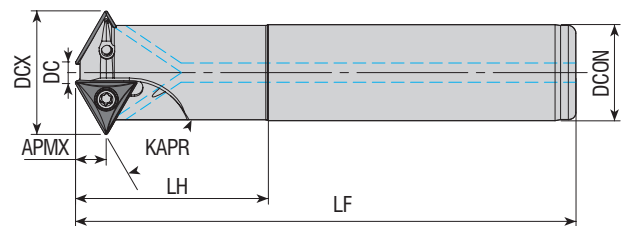

Código del Inserto Le Code de Commande Ordering Code	Stock Stock Stock	Dimension (mm) Dimension (mm) Dimension (mm)							Inserto Plaquette Insert	Recambios / Pièces de Rechange / Spare Parts		
		KAPR	DCX	DCON	DC	LF	LH	ZEFP		APMX	Tornillo Vis Screw	Llave Torx Clé Torx Torx Wrench
ATM60-TB0601-D13-C10-L150-Z02-H	●	60	13	10	2.5	150	40	2	3.3	TBGT 060102	3006-M2x4	80-T06
ATM60-TC0902-D20.5-C16-L150-Z02-H	●	60	20.5	16	5.2	150	40	2	4.7	TC.T 090202	3007-M2.2x5	80-T07
ATM60-TC1102-D26-C20-L150-Z03-H	●	60	26	20	8.3	150	50	3	5.4	TC.T 110202	3008-M2.5x6	80-T08
ATM60-TC16T3-D32-C25-L150-Z02-H	●	60	32	25	6.4	150	50	2	8	TC.T 16T304	4015-M3.5x9	80-T15
ATM60-TC16T3-D40-C32-L250-Z03-H	●	60	40	32	13.7	250	50	3	8			

R: Derecha / Droite / Right L: Izquierda / Gauche / Left

● En Existencia / En stock / In Stock ○ Artículo sin Existencia / Indisponible en Stock / Non Stock Item
Compatible con el Inserto ISO. / Compatible avec ISO Plaquettes. / Compatible with ISO Insert.

Ejemplo de Pedido / Exemple de Commande / Ordering Example

1 Piezas / pcs. / pcs. ATM-C14-D14-W20-L100-Z01-H

Cálculo de Corte : S 369 / Calcul de Coupe : P 369 / Cutting Calculation : 369

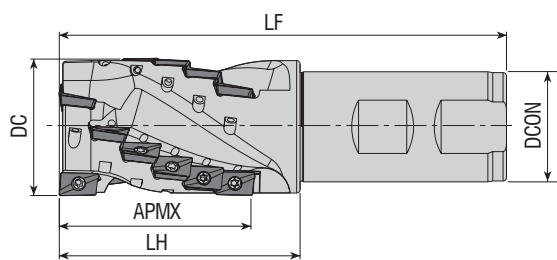
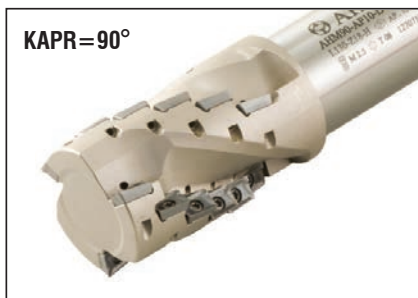

Código del Inserto Le Code de Commande Ordering Code	Stock Stock	Dimension (mm) Dimension (mm)							Inserto Plaquette Insert	Recambios / Pièces de Rechange / Spare Parts		
		ZEFP		DC	DCON	APMX	LH	LF		Tornillo Vis Screw	Llave Torx Clé Torx Torx Wrench	
		Total Total	Eficaz Efficace									
AHM90-AP10-D20-W20-L087-Z0204	●	4	2	20	20	28	37	87				
AHM90-AP10-D20-W20-L087-Z0206	●	6	2	20	20	28	37	87				
AHM90-AP10-D25-W25-L105-Z0208-H	●	8	2	25	25	37	50	105				
AHM90-AP10-D32-W32-L115-Z0315-H	●	15	3	32	32	46	55	115				
AHM90-AP10-D40-W32-L130-Z0318-H	●	18	3	40	32	55	70	130				

Compatible con el Inserto ISO. / Compatible avec ISO Plaquettes. / Compatible with ISO Insert.

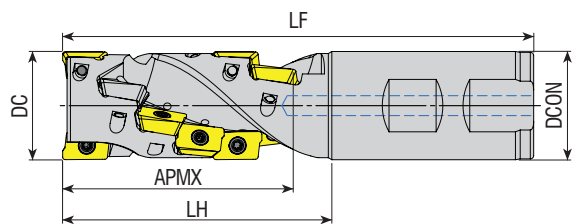

Código del Inserto Le Code de Commande Ordering Code	Stock Stock	Dimension (mm) Dimension (mm)							Inserto Plaquette Insert	Recambios / Pièces de Rechange / Spare Parts		
		ZEFP		DC	DCON	APMX	LH	LF		Tornillo Vis Screw	Llave Torx Clé Torx Torx Wrench	
		Total Total	Eficaz Efficace									
AHM90-AP1204-D32-W32-L140-Z0212-H	●	12	2	32	32	68	80	140				
AHM90-AP1204-D40-W32-L160-Z0321-H	●	21	3	40	32	79	100	160				

R: Derecha / Droite / Right L: Izquierda / Gauche / Left

● En Existencia / En stock / In Stock ○ Artículo sin Existencia / Indisponible en Stock / Non Stock Item
 Compatible con el Inserto TGTC. / Compatible avec TGTC Plaquettes. / Compatible with TGTC Insert.

Ejemplo de Pedido / Exemple de Commande / Ordering Example

1 Piezas / pcs. / pcs. AHM90-AP10-D20-W20-L087-Z0204

Cálculo de Corte : S 369 / Calcul de Coupe : P 369 / Cutting Calculation : 369

konusulan
the spoken kalite...
quality...



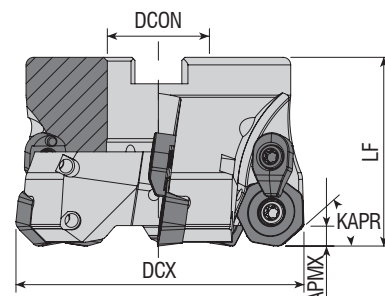

Código del Inserto Le Code de Commande Ordering Code	Stock Stock Stock	Dimension (mm) Dimension (mm) Dimension (mm)					Inserto Plaquette Insert	Recambios / Pièces de Rechange / Spare Parts					
		DCX	ZEFP	DCON	LF	APMX		Tornillo Vis Screw	Abrazadera de Cuñas Mode de Fixation Wedge Clamp	Tornillo de Sujeción Vis de Fixation Wedge Screw	Llave Torx Clé Torx Torx Wrench	Tornillo de Fijación Vis de Fixation Mounting Screw	
AFM42C-XD0806-D063-A27-Z04-H	●	63	4	27	50	12	XDMW 0806..	4020-M4.5x12	ACK-24	4020-M4.5x12	80-T20	2510-M12x35	
AFM42C-XD0806-D080-A27-Z05-H	●	80	5	27	50	12							2514-M16x35
AFM42C-XD0806-D100-A32-Z06-H	●	100	6	32	63	12							
AFM42C-XD0806-D125-B40-Z07	●	125	7	40	63	12							
AFM42C-XD0806-D160-C40-Z08	●	160	8	40	63	12							
AFM42C-XD0806-D200-C60-Z09	●	200	9	60	63	12							

Compatible con el Inserto DJT. / Compatible avec DJT Plaquettes. / Compatible with DJT Insert.

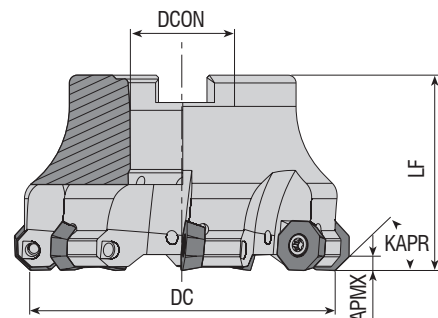

Código del Inserto Le Code de Commande Ordering Code	Stock Stock Stock	Dimension (mm) Dimension (mm) Dimension (mm)					Inserto Plaquette Insert	Recambios / Pièces de Rechange / Spare Parts				
		DC	ZEFP	DCON	LF	APMX		Tornillo Vis Screw	Llave Torx Clé Torx Torx Wrench	Tornillo de Fijación Vis de Fixation Mounting Screw		
AFM43-OD0504-D040-A16-Z04-H	●	40	4	16	40	3.5	OD.. 0504..	4015-M3.5x11	80-T15	2506-M8x30		
AFM43-OD0504-D050-A22-Z05-H	●	50	5	22	40	3.5					2407-M10x30	
AFM43-OD0504-D063-A22-Z06-H	●	63	6	22	40	3.5						
AFM43-OD0504-D080-A27-Z07-H	●	80	7	27	50	3.5						2510-M12x35
AFM43-OD0504-D100-A32-Z08-H	●	100	8	32	50	3.5						

R: Derecha / Droite / Right L: Izquierda / Gauche / Left

● En Existencia / En stock / In Stock ○ Artículo sin Existencia / Indisponible en Stock / Non Stock Item
Compatible con el Inserto WLTR. / Compatible avec WLTR Plaquettes. / Compatible with WLTR Insert.

Ejemplo de Pedido / Exemple de Commande / Ordering Example

1 Piezas / pcs. / pcs. AFM42C-XD0806-D063-A27-Z04-H

Cálculo de Corte : S 369 / Calcul de Coupe : P 369 / Cutting Calculation : 369

Referencia de Montaje : S 366 / Montage Référence : P 366 / Mounting Specifications : 366

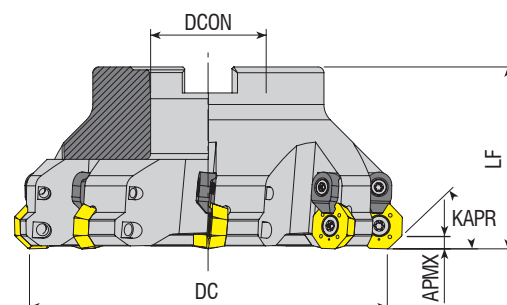

Código del Inserto Le Code de Commande Ordering Code	Stock Stock Stock	Dimension (mm) Dimension (mm) Dimension (mm)					Inserto Plaquette Insert	Recambios / Pièces de Rechange / Spare Parts				
		DC	ZEFP	DCON	LF	APMX		Tornillo Vis Screw	Abrazadera de Cuiñas Mode de Fixation Wedge Clamp	Tornillo de Sujeción Vis de Fixation Wedge Screw	Llave Torx Clé Torx Torx Wrench	Tornillo de Fijación Vis de Fixation Mounting Screw
AFM43C-OD0605-D080-A27-Z06-H	●	80	6	27	50	4	OD.. 0605..	1020-M5x11	ACK-05	4015-M4x11	80-T20	2510-M12x35
AFM43C-OD0605-D100-A32-Z07-H	●	100	7	32	50	4						2514-M16x35
AFM43C-OD0605-D125-B40-Z08	●	125	8	40	63	4						-

Compatible con el Inserto WLTR-LMN. / Compatible avec WLTR-LMN Plaquettes. / Compatible with WLTR-LMN Insert.

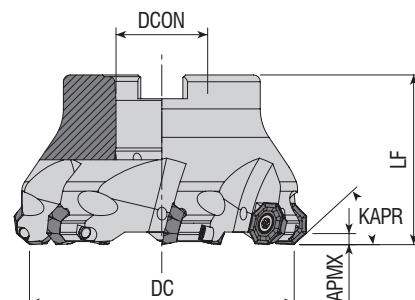

Código del Inserto Le Code de Commande Ordering Code	Stock Stock Stock	Dimension (mm) Dimension (mm) Dimension (mm)					Inserto Plaquette Insert	Recambios / Pièces de Rechange / Spare Parts		
		DC	ZEFP	DCON	LF	APMX		Tornillo Vis Screw	Llave Torx Clé Torx Torx Wrench	Tornillo de Fijación Vis de Fixation Mounting Screw
AFM43-OF05T3-D050-A22-Z05-H	●	50	5	22	40	3	OF.. 05T3..	4015-M4x9	80-T15	2407-M10x30
AFM43-OF05T3-D063-A22-Z06-H	●	63	6	22	40	3		4015-M4x11		2510-M12x35
AFM43-OF05T3-D080-A27-Z07-H	●	80	7	27	50	3		-		
AFM43-OF05T3-D125-B40-Z09	●	125	9	40	63	3		-		

R: Derecha / Droite / Right L: Izquierda / Gauche / Left
● En Existencia / En stock / In Stock ○ Artículo sin Existencia / Indisponible en Stock / Non Stock Item
Compatible con el Inserto ISO. / Compatible avec ISO Plaquettes. / Compatible with ISO Insert.

Ejemplo de Pedido / Exemple de Commande / Ordering Example
1 Piezas / pcs. / pcs. AFM43C-OD0605-D080-A27-Z06-H
Cálculo de Corte : S 369 / Calcul de Coupe : P 369 / Cutting Calculation : 369
Referencia de Montaje : S 366 / Montage Référence : P 366 / Mounting Specifications : 366

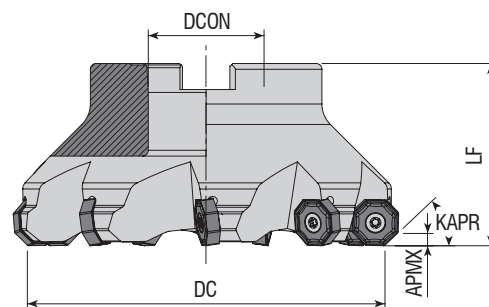

Código del Inserto Le Code de Commande Ordering Code	Stock Stock Stock	Dimension (mm) Dimension (mm) Dimension (mm)					Inserto Plaquette Insert	Recambios / Pièces de Rechange / Spare Parts		
		DC	ZEFP	DCON	LF	APMX		Tornillo Vis Screw	Llave Torx Clé Torx Torx Wrench	Tornillo de Fijación Vis de Fixation Mounting Screw
AFM43-ON0604-D050-A22-Z05-H	●	50	5	22	40	4	ON.. 0604..	4015-M4x11	80-T15	2407-M10x30 2510-M12x35 2514-M16x35 -
AFM43-ON0604-D063-A22-Z06-H	●	63	6	22	40	4				
AFM43-ON0604-D080-A27-Z07-H	●	80	7	27	50	4				
AFM43-ON0604-D100-A32-Z08-H	●	100	8	32	50	4				
AFM43-ON0604-D125-B40-Z09	●	125	9	40	63	4				

Compatible con el Inserto ZCC. / Compatible avec ZCC Plaquettes. / Compatible with ZCC Insert.

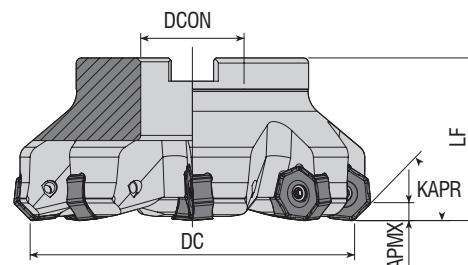

Código del Inserto Le Code de Commande Ordering Code	Stock Stock Stock	Dimension (mm) Dimension (mm) Dimension (mm)					Inserto Plaquette Insert	Recambios / Pièces de Rechange / Spare Parts		
		DC	ZEFP	DCON	LF	APMX		Tornillo Vis Screw	Llave Torx Clé Torx Torx Wrench	Tornillo de Fijación Vis de Fixation Mounting Screw
AFM44-ON0606-D063-A22-Z06-H	●	63	6	22	40	3.8	ONHX 0606..	4020-M4.5x12	80-T20	2407-M10x30 2510-M12x35 2514-M16x35
AFM44-ON0606-D080-A27-Z08-H	●	80	8	27	50	3.8				
AFM44-ON0606-D100-A32-Z10-H	●	100	10	32	50	3.8				

R: Derecha / Droite / Right L: Izquierda / Gauche / Left

● En Existencia / En stock / In Stock ○ Artículo sin Existencia / Indisponible en Stock / Non Stock Item
Compatible con el Inserto KRLY. / Compatible avec KRLY Plaquettes. / Compatible with KRLY Insert.

Ejemplo de Pedido / Exemple de Commande / Ordering Example

1 Piezas / pcs. / pcs. AFM43-ON0604-D050-A22-Z05-H
Cálculo de Corte : S 369 / Calcul de Coupe : P 369 / Cutting Calculation : 369
Referencia de Montaje : S 366 / Montage Référence : P 366 / Mounting Specifications : 366

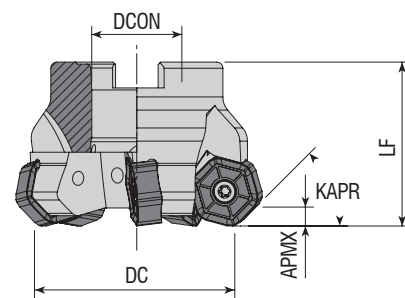

Código del Inserto Le Code de Commande Ordering Code	Stock Stock Stock	Dimension (mm) Dimension (mm) Dimension (mm)					Inserto Plaquette Insert	Recambios / Pièces de Rechange / Spare Parts		
		DC	ZEFP	DCON	LF	APMX		Tornillo Vis Screw	Llave Torx Clé Torx Torx Wrench	Tornillo de Fijación Vis de Fixation Mounting Screw
AFM45-HN0905-D050-A22-Z05-H	●	50	5	22	40	4.5	HN.. 0905..	4015-M4x11	80-T15	2407-M10x30
AFM45-HN0905-D063-A22-Z06-H	●	63	6	22	40	4.5				2510-M12x35
AFM45-HN0905-D080-A27-Z07-H	●	80	7	27	50	4.5				2514-M16x35
AFM45L-HN0905-D100-A32-Z08-H	●	100	8	32	50	4.5				-
AFM45-HN0905-D125-B40-Z10	●	125	10	40	63	4.5				
AFM45L-HN0905-D125-B40-Z10	●	125	10	40	63	4.5				
AFM45-HN0905-D160-C40-Z12	●	160	12	40	63	4.5				
AFM45L-HN0905-D160-C40-Z12	●	160	12	40	63	4.5				
AFM45-HN0905-D200-C60-Z16	●	200	16	60	63	4.5				
AFM45L-HN0905-D200-C60-Z16	●	200	16	60	63	4.5				

Compatible con el Inserto WDA. / Compatible avec WDA Plaquettes. / Compatible with WDA Insert.

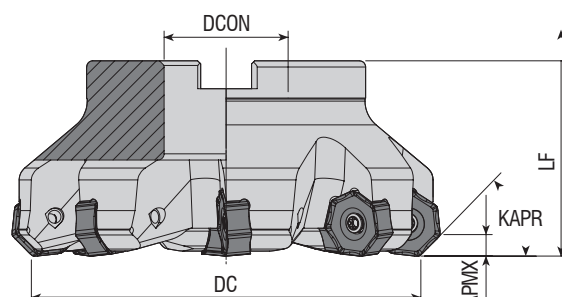
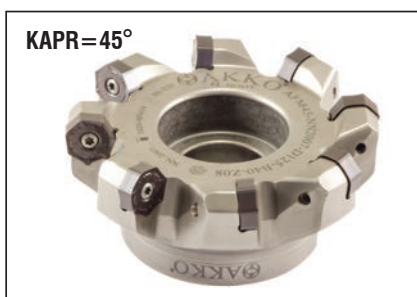

Código del Inserto Le Code de Commande Ordering Code	Stock Stock Stock	Dimension (mm) Dimension (mm) Dimension (mm)					Inserto Plaquette Insert	Recambios / Pièces de Rechange / Spare Parts		
		DC	ZEFP	DCON	LF	APMX		Tornillo Vis Screw	Llave Torx Clé Torx Torx Wrench	Tornillo de Fijación Vis de Fixation Mounting Screw
AFM45-NN2007-D100-A32-Z07-H	●	100	7	32	50	6	NNMU 2007..	1020-M5x14	80-T20	2514-M16x35
AFM45-NN2007-D125-B40-Z08	●	125	8	40	63	6				
AFM45-NN2007-D160-C40-Z10	●	160	10	40	63	6				

R: Derecha / Droite / Right L: Izquierda / Gauche / Left

● En Existencia / En stock / In Stock ○ Artículo sin Existencia / Indisponible en Stock / Non Stock Item
Compatible con el Inserto MTSBH. / Compatible avec MTSBH Plaquettes. / Compatible with MTSBH Insert.

Ejemplo de Pedido / Exemple de Commande / Ordering Example

1 Piezas / pcs. / pcs. AFM45-HN0905-D063-A22-Z06-H

Cálculo de Corte : S 369 / Calcul de Coupe : P 369 / Cutting Calculation : 369

Referencia de Montaje : S 366 / Montage Référence : P 366 / Mounting Specifications : 366

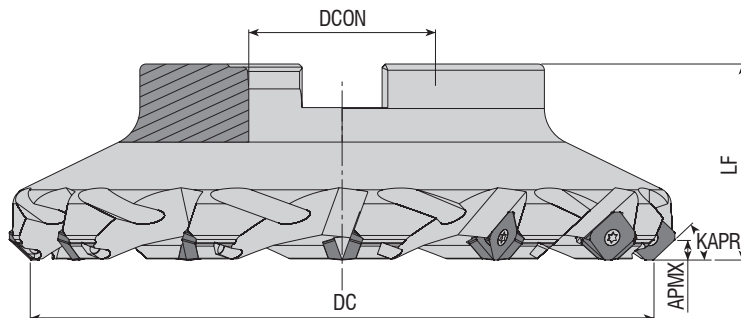

Código del Inserto Le Code de Commande Ordering Code	Stock Stock	Dimension (mm) Dimension (mm)					Inserto Plaquette Insert	Recambios / Pièces de Rechange / Spare Parts			
		DC	ZEPF	DCON	LF	APMX		Tornillo Vis Screw	Llave Torx Clé Torx Torx Wrench	Tornillo de Fijación Vis de Fixation Mounting Screw	
AFM45-SE12-D050-A22-Z04-H	●	50	4	22	40	6	SE.. 12T3.. R245-12T3..	4015-M3.5x11	80-T15	2407-M10x30	
AFM45L-SE12-D050-A22-Z04-H	●	50	4	22	40	6					
AFM45-SE12-D063-A22-Z05-H	●	63	5	22	40	6					
AFM45L-SE12-D063-A22-Z05-H	●	63	5	22	40	6					
AFM45-SE12-D080-A27-Z06-H	●	80	6	27	50	6				2510-M12x35	
AFM45L-SE12-D080-A27-Z06-H	●	80	6	27	50	6					
AFM45-SE12-D100-A32-Z07-H	●	100	7	32	50	6				2514-M16x35	
AFM45-SE12-D125-B40-Z08	●	125	8	40	63	6					
AFM45-SE12-D160-C40-Z10	●	160	10	40	63	6				-	
AFM45L-SE12-D160-C40-Z10	●	160	10	40	63	6					
AFM45-SE12-D200-C60-Z12	●	200	12	60	63	6	-	-	-		

Compatible con el Inserto ZCC-SNDVK. / Compatible avec ZCC-SNDVK Plaquettes. / Compatible with ZCC-SNDVK Insert.

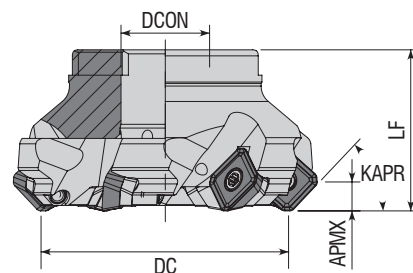

Código del Inserto Le Code de Commande Ordering Code	Stock Stock	Dimension (mm) Dimension (mm)					Inserto Plaquette Insert	Recambios / Pièces de Rechange / Spare Parts									
		DC	ZEPF	DCON	LF	APMX		Cuñas Assise Shim	Tornillo de Placa Vis à Assise Shim Screw	Tornillo Vis Screw	Llave Torx Clé Torx Torx Wrench	Tornillo de Fijación Vis de Fixation Mounting Screw					
AFM45-SE13-D050-A22-Z04-H	●	50	4	22	40	6	SEMT 13T3..	AASE-3-0001	AAV-16-M3.5x8	4015-M3.5x12	80-T15	2407-M10x30					
AFM45-SE13-D063-A22-Z05-H	●	63	5	22	40	6											
AFM45-SE13-D080-A27-Z06-H	●	80	6	27	50	6							2510-M12x35				
AFM45S-SE13-D050-A22-Z05-H	●	50	5	22	40	6											
AFM45S-SE13-D063-A22-Z06-H	●	63	6	22	40	6						2407-M10x30					
AFM45S-SE13-D080-A27-Z08-H	●	80	8	27	50	6											
AFM45S-SE13-D100-A32-Z10-H	●	100	10	32	50	6						2510-M12x35					
AFM45S-SE13-D125-B40-Z12	●	125	12	40	63	6											
																	2514-M16x35
																	-

R: Derecha / Droite / Right L: Izquierda / Gauche / Left

● En Existencia / En stock / In Stock ○ Artículo sin Existencia / Indisponible en Stock / Non Stock Item

Compatible con el Inserto SMTM-DJT. / Compatible avec SMTM-DJT Plaquettes. / Compatible with SMTM-DJT Insert.

Ejemplo de Pedido / Exemple de Commande / Ordering Example

1 Piezas / pcs. / pcs. AFM45-SE12-D050-A22-Z04-H

Cálculo de Corte : S 369 / Calcul de Coupe : P 369 / Cutting Calculation : 369

Referencia de Montaje : S 366 / Montage Référence : P 366 / Mounting Specifications : 366

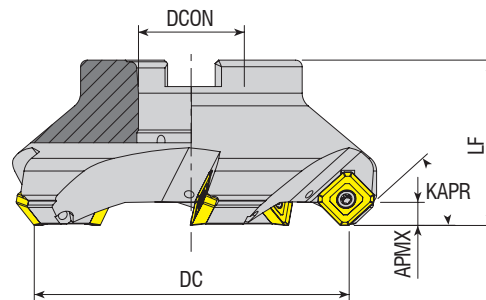

Código del Inserto Le Code de Commande Ordering Code	Stock Stock Stock	Dimension (mm) Dimension (mm) Dimension (mm)					Inserto Plaquette Insert	Recambios / Pièces de Rechange / Spare Parts				
		DC	ZEPF	DCON	LF	APMX		Tornillo Vis Screw	Llave Torx Clé Torx Torx Wrench	Tornillo de Fijación Vis de Fixation Mounting Screw		
AFM45-SE14M4-D063-A22-Z04-H	●	63	4	22	40	7	SE.. 14M4..		4015-M3.5x11			2407-M10x30
AFM45-SE14M4-D080-A27-Z05-H	●	80	5	27	50	7						2510-M12x35
AFM45-SE14M4-D100-A32-Z05-H	●	100	5	32	50	7						2514-M16x35
AFM45-SE14M4-D125-B40-Z06	●	125	6	40	63	7						-
AFM45-SE14M4-D160-C40-Z07	●	160	7	40	63	7						-

Compatible con el Inserto KRLY. / Compatible avec KRLY Plaquettes. / Compatible with KRLY Insert.

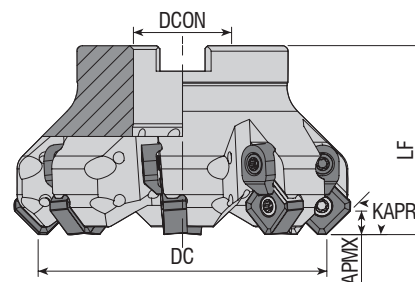

Código del Inserto Le Code de Commande Ordering Code	Stock Stock Stock	Dimension (mm) Dimension (mm) Dimension (mm)					Inserto Plaquette Insert	Tornillo Vis Screw	Recambios / Pièces de Rechange / Spare Parts				
		DC	ZEPF	DCON	LF	APMX			Abrazadera de Cuñas Mode de Fixation Wedge Clamp	Tornillo de Sujeción Vis de Fixation Wedge Screw	Llave Torx Clé Torx Torx Wrench	Tornillo de Fijación Vis de Fixation Mounting Screw	
AFM45C-SN12..-D050-A22-Z04-H	●	50	4	22	42	6	SN.. 12..						
AFM45C-SN12..-D050-A22-Z05-H	●	50	5	22	42	6							
AFM45C-SN12..-D063-A22-Z06-H	●	63	6	22	42	6							2407-M10X30
AFM45C-SN12..-D063-A22-Z07-H	●	63	7	22	42	6							
AFM45CL-SN12..-D063-A22-Z07-H	●	63	7	22	42	6							
AFM45C-SN12..-D080-A27-Z07-H	●	80	7	27	52	6							
AFM45C-SN12..-D080-A27-Z08-H	●	80	8	27	52	6							2510-M12x35
AFM45CL-SN12..-D080-A27-Z08-H	●	80	8	27	52	6							
AFM45C-SN12..-D100-A32-Z08-H	●	100	8	32	52	6							
AFM45C-SN12..-D100-A32-Z10-H	●	100	10	32	52	6							2514-M16x35
AFM45CL-SN12..-D100-A32-Z10-H	●	100	10	32	52	6							
AFM45C-SN12..-D125-B40-Z11	●	125	11	40	65	6							
AFM45CL-SN12..-D125-B40-Z11	●	125	11	40	65	6							
AFM45C-SN12..-D160-C40-Z12	●	160	12	40	65	6							-
AFM45C-SN12..-D200-C60-Z14	●	200	14	60	65	6							
AFM45CL-SN12..-D200-C60-Z14	●	200	14	60	65	6							

R: Derecha / Droite / Right L: Izquierda / Gauche / Left

● En Existencia / En stock / In Stock ○ Artículo sin Existencia / Indisponible en Stock / Non Stock Item

Compatible con el Inserto WLTR-LMN-ACHTK. / Compatible avec WLTR-LMN-ACHTK Plaquettes. / Compatible with WLTR-LMN-ACHTK Insert.

Referencia de Montaje : S 366 / Montage Référence : P 366 / Mounting Specifications : 366

Ejemplo de Pedido / Exemple de Commande / Ordering Example

1 Piezas / pcs. / pcs. AFM45-SE14M4-D063-A22-Z04-H

Cálculo de Corte : S 369 / Calcul de Coupe : P 369 / Cutting Calculation : 369

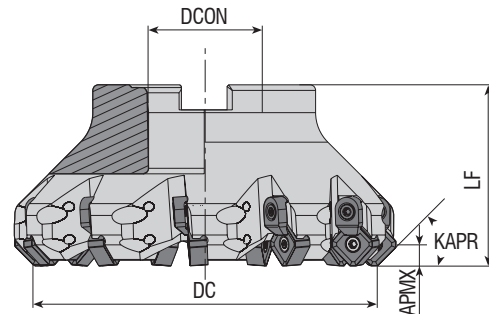
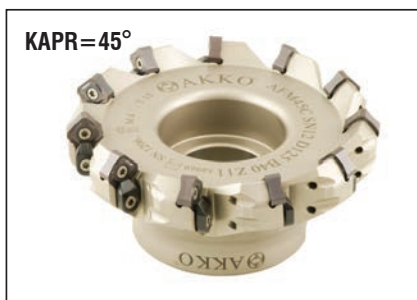

Código del Inserto Le Code de Commande Ordering Code	Stock Stock Stock	Dimension (mm) Dimension (mm) Dimension (mm)					Inserto Plaquette Insert	Recambios / Pièces de Rechange / Spare Parts					
		DC	ZEPF	DCON	LF	APMX		Tornillo Vis Screw	Abrazadera de Cuiñas Mode de Fixation Wedge Clamp	Tornillo de Sujeción Vis de Fixation Wedge Screw	Llave Torx Clé Torx Torx Wrench	Tornillo de Fijación Vis de Fixation Mounting Screw	
AFM45C-SN1206-D050-A22-Z04-H	●	50	4	22	42	6	SN.. 1206..						
AFM45CL-SN1206-D050-A22-Z05-H	●	50	5	22	42	6							
AFM45C-SN1206-D050-A22-Z05-H	●	50	5	22	42	6							
AFM45C-SN1206-D063-A22-Z06-H	●	63	6	22	42	6							2407-M10x30
AFM45C-SN1206-D063-A22-Z07-H	●	63	7	22	42	6							2510-M12x35
AFM45CL-SN1206-D063-A22-Z07-H	●	63	7	22	42	6							
AFM45C-SN1206-D080-A27-Z07-H	●	80	7	27	52	6							2514-M16x35
AFM45C-SN1206-D080-A27-Z08-H	●	80	8	27	52	6							
AFM45CL-SN1206-D080-A27-Z08-H	●	80	8	27	52	6							-
AFM45C-SN1206-D100-A32-Z08-H	●	100	8	32	52	6							
AFM45C-SN1206-D100-A32-Z10-H	●	100	10	32	52	6							-
AFM45CL-SN1206-D100-A32-Z10-H	●	100	10	32	52	6							
AFM45C-SN1206-D125-B40-Z11	●	125	11	40	65	6							-
AFM45CL-SN1206-D125-B40-Z11	●	125	11	40	65	6							
AFM45C-SN1206-D160-C40-Z12	●	160	12	40	65	6							-
AFM45C-SN1206-D200-C60-Z14	●	200	14	60	65	6							
AFM45CL-SN1206-D200-C60-Z14	●	200	14	60	65	6							-

Compatible con el Inserto KRLY-PLBT-BHLR. / Compatible avec KRLY-PLBT-BHLR Plaquettes. / Compatible with KRLY-PLBT-BHLR Insert.

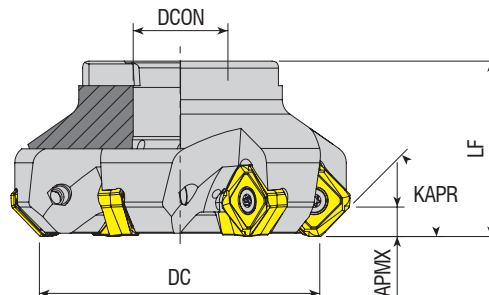

Código del Inserto Le Code de Commande Ordering Code	Stock Stock Stock	Dimension (mm) Dimension (mm) Dimension (mm)					Inserto Plaquette Insert	Recambios / Pièces de Rechange / Spare Parts					
		DC	ZEPF	DCON	LF	APMX		Tornillo Vis Screw	Llave Torx Clé Torx Torx Wrench	Tornillo de Fijación Vis de Fixation Mounting Screw			
AFM45-SA1706-D080-A27-Z06-H	●	80	6	27	50	8.4	SAKU 1706..				2510-M12x35		
AFM45-SA1706-D100-A32-Z07-H	●	100	7	32	50	8.4					1020-M5x14	80-T20	2514-M16x35
AFM45-SA1706-D125-B40-Z09	●	125	9	40	63	8.4					-	-	-

R: Derecha / Droite / Right L: Izquierda / Gauche / Left

● En Existencia / En stock / In Stock ○ Artículo sin Existencia / Indisponible en Stock / Non Stock Item
Compatible con el Inserto CRTZT. / Compatible avec CRTZT Plaquettes. / Compatible with CRTZT Insert.

Ejemplo de Pedido / Exemple de Commande / Ordering Example

1 Piezas / pcs. / pcs. AFM45C-SN1206-D050-A22-Z04-H

Cálculo de Corte : S 369 / Calcul de Coupe : P 369 / Cutting Calculation : 369

Referencia de Montaje : S 366 / Montage Référence : P 366 / Mounting Specifications : 366

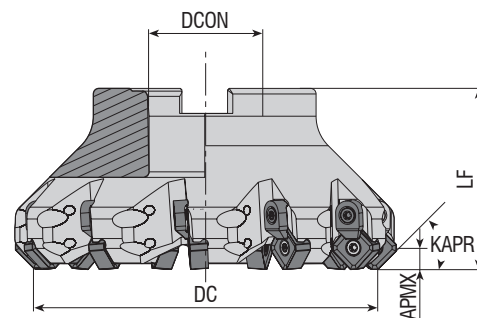

Código del Inserto Le Code de Commande Ordering Code	Stock Stock Stock	Dimension (mm) Dimension (mm) Dimension (mm)					Inserto Plaquette Insert	Recambios / Pièces de Rechange / Spare Parts					
		DC	ZEPF	DCON	LF	APMX		Tornillo Vis Screw	Abrazadera de Cuiñas Mode de Fixation Wedge Clamp	Tornillo de Sujeción Vis de Fixation Wedge Screw	Llave Torx Clé Torx Torx Wrench	Tornillo de Fijación Vis de Fixation Mounting Screw	
AFM45C-SN12Z-D050-A22-Z05-H	●	50	5	22	42	6	SNEG 1205..						2407-M10X30
AFM45C-SN12Z-D063-A22-Z06-H	●	63	6	22	42	6							2510-M12x35
AFM45C-SN12Z-D080-A27-Z07-H	●	80	7	27	52	6							2514-M16x35
AFM45C-SN12Z-D100-A32-Z09-H	●	100	9	32	52	6							-
AFM45C-SN12Z-D125-B40-Z11	●	125	11	40	65	6							-
AFM45C-SN12Z-D160-C40-Z12	●	160	12	60	65	6							-
AFM45C-SN12Z-D200-C60-Z14	●	200	14	60	65	6							-

Compatible con el Inserto ZCC. / Compatible avec ZCC Plaquettes. / Compatible with ZCC Insert.

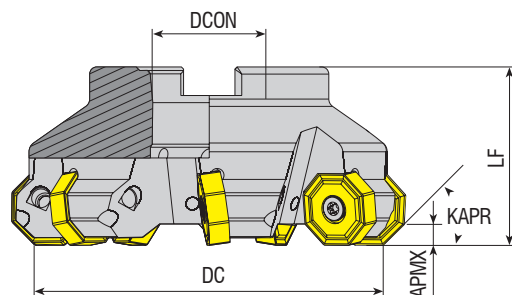

Código del Inserto Le Code de Commande Ordering Code	Stock Stock Stock	Dimension (mm) Dimension (mm) Dimension (mm)					Inserto Plaquette Insert	Recambios / Pièces de Rechange / Spare Parts					
		DC	ZEPF	DCON	LF	APMX		Tornillo Vis Screw	Llave Torx Clé Torx Torx Wrench	Tornillo de Fijación Vis de Fixation Mounting Screw			
AFM45-ON0806-D063-A22-Z05-H	●	63	5	22	40	5.5	ON.. 0806..						2508-M10x30
AFM45-ON0806-D063-A22-Z06-H	●	63	6	22	40	5.5							2510-M12x35
AFM45-ON0806-D080-A27-Z06-H	●	80	6	27	50	5.5							2514-M16x35
AFM45-ON0806-D080-A27-Z08-H	●	80	8	27	50	5.5							-
AFM45-ON0806-D100-A32-Z07-H	●	100	7	32	50	5.5							-
AFM45-ON0806-D100-A32-Z10-H	●	100	10	32	50	5.5							-
AFM45-ON0806-D125-B40-Z08	●	125	8	40	63	5.5							-
AFM45-ON0806-D125-B40-Z12	●	125	12	40	63	5.5							-
AFM45-ON0806-D160-C40-Z10	●	160	10	40	63	5.5							-
AFM45-ON0806-D160-C40-Z14	●	160	14	40	63	5.5							-
AFM45-ON0806-D200-C60-Z12	●	200	12	60	63	5.5							-
AFM45-ON0806-D250-C60-Z14	●	250	14	60	63	5.5							-
AFM45-ON0806-D315-D60-Z16	●	315	16	60	63	5.5							-

R: Derecha / Droite / Right L: Izquierda / Gauche / Left

● En Existencia / En stock / In Stock ○ Artículo sin Existencia / Indisponible en Stock / Non Stock Item
Compatible con el Inserto ISO. / Compatible avec ISO Plaquettes. / Compatible with ISO Insert.

Ejemplo de Pedido / Exemple de Commande / Ordering Example

1 Piezas / pcs. / pcs. AFM45C-SN12Z-D050-A22-Z05-H

Cálculo de Corte : S 369 / Calcul de Coupe : P 369 / Cutting Calculation : 369

Referencia de Montaje : S 366 / Montage Référence : P 366 / Mounting Specifications : 366

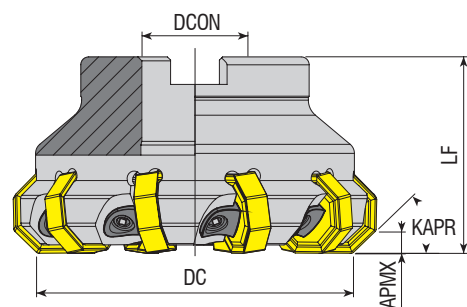

Código del Inserto Le Code de Commande Ordering Code	Stock Stock Stock	Dimension (mm) Dimension (mm) Dimension (mm)					Inserto Plaquette Insert	Recambios / Pièces de Rechange / Spare Parts			
		DC	ZEFP	DCON	LF	APMX		Abrazadera de Cuñas Mode de Fixation Wedge Clamp	Tornillo de Sujeción Vis de Fixation Wedge Screw	Llaves Allen Clés Allen Allen Wrench	Tornillo de Fijación Vis de Fixation Mounting Screw
AFM45C-ON0806-D080-A27-Z10	●	80	10	27	50	5.5	ON.. 0806..	ACK-26	AKV-26-M6x0.75x20	AAL-03-3	2510-M12x35
AFM45C-ON0806-D100-A32-Z14	●	100	14	32	50	5.5					2514-M16x35
AFM45C-ON0806-D125-B40-Z18	●	125	18	40	63	5.5					-
AFM45C-ON0806-D160-C40-Z22	●	160	22	40	63	5.5					-

Compatible con el Inserto ISO. / Compatible avec ISO Plaquettes. / Compatible with ISO Insert.

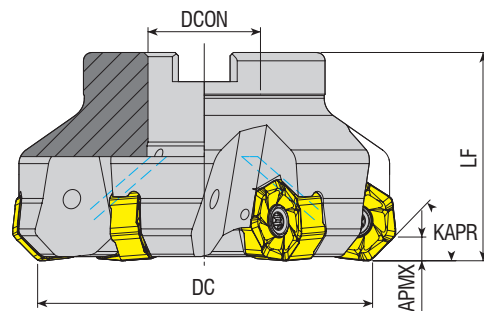

Código del Inserto Le Code de Commande Ordering Code	Stock Stock Stock	Dimension (mm) Dimension (mm) Dimension (mm)					Inserto Plaquette Insert	Recambios / Pièces de Rechange / Spare Parts			
		DC	ZEFP	DCON	LF	APMX		Tornillo Vis Screw	Abrazadera de Cuñas Mode de Fixation Wedge Clamp	Tornillo de Sujeción Vis de Fixation Wedge Screw	Llave Torx Clé Torx Torx Wrench
AFM45-XN0906-D063-A22-Z06-H	●	63	6	22	50	5	XNMU 0906..	1120-M5x13	-	80-T20	2407-M10x30
AFM45-XN0906-D080-A27-Z06-H	●	80	6	27	50	5					2510-M12x35
AFM45-XN0906-D100-A32-Z07-H	●	100	7	32	55	5					2514-M16x35
AFM45-XN0906-D125-B40-Z08	●	125	8	40	63	5					-

R: Derecha / Droite / Right L: Izquierda / Gauche / Left

● En Existencia / En stock / In Stock ○ Artículo sin Existencia / Indisponible en Stock / Non Stock Item
Compatible con el Inserto TGTC. / Compatible avec TGTC Plaquettes. / Compatible with TGTC Insert.

Ejemplo de Pedido / Exemple de Commande / Ordering Example

1 Piezas / pcs. / pcs. AFM45C-ON0806-D080-A27-Z10

Cálculo de Corte : S 369 / Calcul de Coupe : P 369 / Cutting Calculation : 369

Referencia de Montaje : S 366 / Montage Référence : P 366 / Mounting Specifications : 366

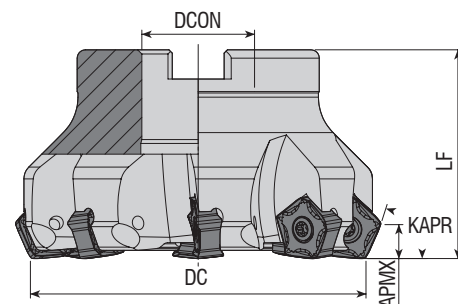

Código del Inserto Le Code de Commande Ordering Code	Stock Stock Stock	Dimension (mm) Dimension (mm) Dimension (mm)					Inserto Plaquette Insert	Recambios / Pièces de Rechange / Spare Parts			
		DC	ZEFP	DCON	LF	APMX		Tornillo Vis Screw	Llave Torx Clé Torx Torx Wrench	Tornillo de Fijación Vis de Fixation Mounting Screw	
AFM66-PN0905-D050-A22-Z05	●	50	5	22	40	8	PNMU 0905..				
AFM66-PN0905-D063-A22-Z06	●	63	6	22	40	8					
AFM66-PN0905-D080-A27-Z08	●	80	8	27	50	8					2508-M10x30
AFM66-PN0905-D100-A32-Z10	●	100	10	32	50	8					2510-M12x35
AFM66-PN0905-D125-B40-Z12	●	125	12	40	63	8					2514-M16x35

Compatible con el Inserto KYCR. / Compatible avec KYCR Plaquettes. / Compatible with KYCR Insert.

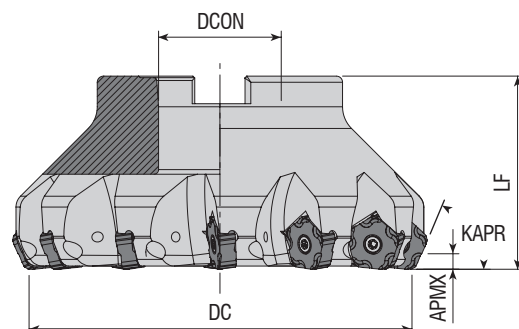

Código del Inserto Le Code de Commande Ordering Code	Stock Stock Stock	Dimension (mm) Dimension (mm) Dimension (mm)					Inserto Plaquette Insert	Recambios / Pièces de Rechange / Spare Parts			
		DC	ZEFP	DCON	LF	APMX		Tornillo Vis Screw	Llave Torx Clé Torx Torx Wrench	Tornillo de Fijación Vis de Fixation Mounting Screw	
AFM67-PN1105-D050-A22-Z05	●	50	5	22	50	5	PNEG 1105..				
AFM67-PN1105-D063-A22-Z06	●	63	6	22	50	5					
AFM67-PN1105-D080-A27-Z08	●	80	8	27	50	5					2508-M10x30
AFM67-PN1105-D100-B32-Z10	●	100	10	32	50	5					2510-M12x35
AFM67-PN1105-D125-B40-Z12	●	125	12	40	63	5					-
AFM67-PN1105-D160-C40-Z14	●	160	14	40	63	5	-				

R: Derecha / Droite / Right L: Izquierda / Gauche / Left
● En Existencia / En stock / In Stock ○ Artículo sin Existencia / Indisponible en Stock / Non Stock Item
Compatible con el Inserto ZCC. / Compatible avec ZCC Plaquettes. / Compatible with ZCC Insert.

Ejemplo de Pedido / Exemple de Commande / Ordering Example
1 Piezas / pcs. / pcs. AFM66-PN0905-D050-A22-Z05
Cálculo de Corte : S 369 / Calcul de Coupe : P 369 / Cutting Calculation : 369
Referencia de Montaje : S 366 / Montage Référence : P 366 / Mounting Specifications : 366

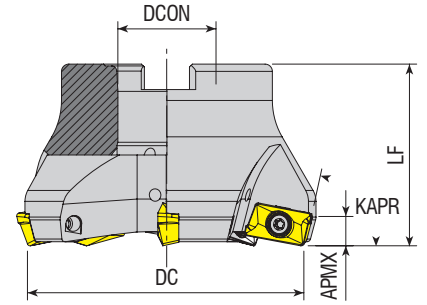

Código del Inserto Le Code de Commande Ordering Code	Stock Stock Stock	Dimension (mm) Dimension (mm) Dimension (mm)					Inserto Plaquette Insert	Recambios / Pièces de Rechange / Spare Parts		
		DC	ZEFP	DCON	LF	APMX		Tornillo Vis Screw	Llave Torx Clé Torx Torx Wrench	Tornillo de Fijación Vis de Fixation Mounting Screw
AFM75-AP16-D063-A22-Z04-H	●	63	4	22	40	6	AP. 1604..			2508-M10x30
AFM75-AP16-D080-A27-Z05-H	●	80	5	27	50	6				2510-M12x35
AFM75-AP16-D100-A32-Z06-H	●	100	6	32	50	6				2514-M16x35
AFM75-AP16-D125-B40-Z07	●	125	7	40	63	6				-

Compatible con el Inserto ISO. / Compatible avec ISO Plaquettes. / Compatible with ISO Insert.

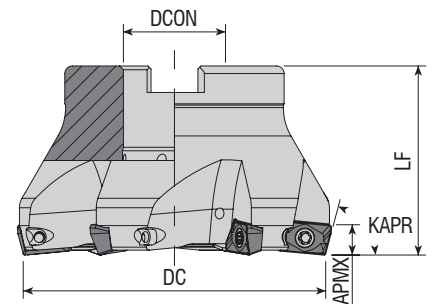

Código del Inserto Le Code de Commande Ordering Code	Stock Stock Stock	Dimension (mm) Dimension (mm) Dimension (mm)					Inserto Plaquette Insert	Recambios / Pièces de Rechange / Spare Parts		
		DC	ZEFP	DCON	LF	APMX		Tornillo Vis Screw	Llave Torx Clé Torx Torx Wrench	Tornillo de Fijación Vis de Fixation Mounting Screw
AFM75-X012-D050-A22-Z04-H	●	50	4	22	40	-	XOMX 1204..			2508-M10x30
AFM75-X012-D063-A22-Z05-H	●	63	5	22	40	-				2510-M12x35
AFM75-X012-D080-A27-Z06-H	●	80	6	27	50	-				

R: Derecha / Droite / Right L: Izquierda / Gauche / Left

● En Existencia / En stock / In Stock ○ Artículo sin Existencia / Indisponible en Stock / Non Stock Item

Compatible con el Inserto SC. / Compatible avec SC Plaquettes. / Compatible with SC Insert.

Ejemplo de Pedido / Exemple de Commande / Ordering Example

1 Piezas / pcs. / pcs. AFM75-AP16-D063-A22-Z04-H

Cálculo de Corte : S 369 / Calcul de Coupe : P 369 / Cutting Calculation : 369

Referencia de Montaje : S 366 / Montage Référence : P 366 / Mounting Specifications : 366

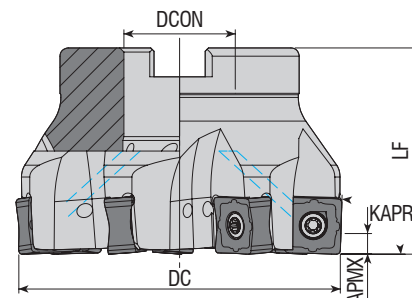

Código del Inserto Le Code de Commande Ordering Code	Stock Stock	Dimension (mm) Dimension (mm) Dimension (mm)					Inserto Plaquette Insert	Recambios / Pièces de Rechange / Spare Parts			
		DC	ZEPF	DCON	LF	APMX		Tornillo Vis Screw	Llave Torx Clé Torx Torx Wrench	Tornillo de Fijación Vis de Fixation Mounting Screw	
AFM88-SN1305-D050-A22-Z04	●	50	4	22	40	5	SNMU 1305..				
AFM88-SN1305-D050-A22-Z05	●	50	5	22	40	5					
AFM88-SN1305-D063-A22-Z05	●	63	5	22	40	5					2508-M10x30
AFM88-SN1305-D063-A22-Z07	●	63	7	22	40	5					2510-M12x35
AFM88-SN1305-D080-A27-Z06	●	80	6	27	50	5					
AFM88-SN1305-D080-A27-Z09	●	80	9	27	50	5					
AFM88-SN1305-D100-A32-Z07	●	100	7	32	50	5					2514-M16x35
AFM88-SN1305-D100-A32-Z11	●	100	11	32	50	5					
AFM88-SN1305-D125-B40-Z13	●	125	13	40	63	5					-

Compatible con el Inserto KYCR. / Compatible avec KYCR Plaquettes. / Compatible with KYCR Insert.

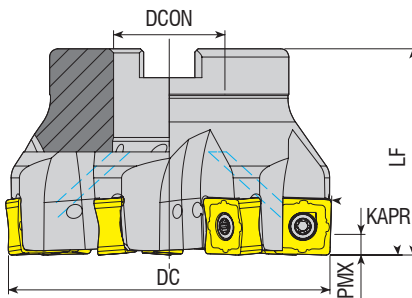

Código del Inserto Le Code de Commande Ordering Code	Stock Stock	Dimension (mm) Dimension (mm) Dimension (mm)					Inserto Plaquette Insert	Recambios / Pièces de Rechange / Spare Parts		
		DC	ZEPF	DCON	LF	APMX		Tornillo Vis Screw	Llave Torx Clé Torx Torx Wrench	Tornillo de Fijación Vis de Fixation Mounting Screw
AFM88-SN1306-D050-A22-Z05-H	●	50	5	22	40	5	SNGX 1306..			
AFM88-SN1306-D063-A22-Z06-H	●	63	6	22	40	5				
AFM88-SN1306-D080-A27-Z07-H	●	80	7	27	50	5				

R: Derecha / Droite / Right L: Izquierda / Gauche / Left

● En Existencia / En stock / In Stock ○ Artículo sin Existencia / Indisponible en Stock / Non Stock Item
Compatible con el Inserto TGTC. / Compatible avec TGTC Plaquettes. / Compatible with TGTC Insert.

Ejemplo de Pedido / Exemple de Commande / Ordering Example

1 Piezas / pcs. / pcs. AFM88-SN1305-D050-A22-Z04

Cálculo de Corte : S 369 / Calcul de Coupe : P 369 / Cutting Calculation : 369

Referencia de Montaje : S 366 / Montage Référence : P 366 / Mounting Specifications : 366

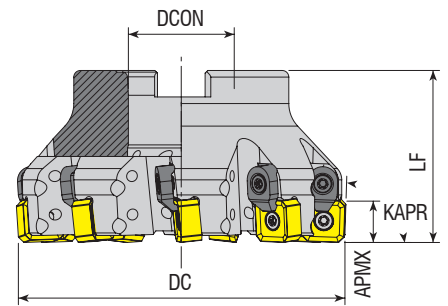

Código del Inserto Le Code de Commande Ordering Code	Stock Stock	Dimension (mm) Dimension (mm)					Inserto Plaqueette Insert	Recambios / Pièces de Rechange / Spare Parts										
		DC	ZEFP	DCON	LF	APMX		Tornillo Vis Screw	Abrazadera de Cuiñas Mode de Fixation Wedge Clamp	Tornillo de Sujeción Vis de Fixation Wedge Screw	Llave Torx Clé Torx Torx Wrench	Tornillo de Fijación Vis de Fixation Mounting Screw						
AFM88C-SN1206-D050-A22-Z05-H	●	50	5	22	40	11.5	SN.. 1206..						2508-M10x30					
AFM88C-SN1206-D063-A22-Z06-H	●	63	6	22	40	11.5								4615-M4x11	ACK-05	4015-M4x11	80-T15	2510-M12x35
AFM88C-SN1206-D080-A27-Z07-H	●	80	7	27	50	11.5												2514-M16x35
AFM88C-SN1206-D100-A32-Z09-H	●	100	9	32	52	11.5												

Compatible con el Inserto ISO. / Compatible avec ISO Plaquettes. / Compatible with ISO Insert.

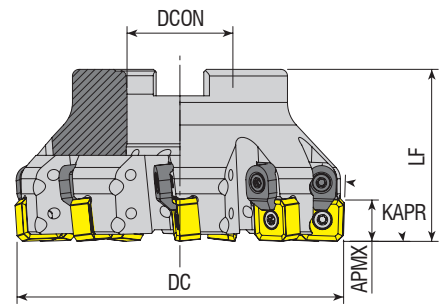

Código del Inserto Le Code de Commande Ordering Code	Stock Stock	Dimension (mm) Dimension (mm)					Inserto Plaqueette Insert	Recambios / Pièces de Rechange / Spare Parts										
		DC	ZEFP	DCON	LF	APMX		Tornillo Vis Screw	Abrazadera de Cuiñas Mode de Fixation Wedge Clamp	Tornillo de Sujeción Vis de Fixation Wedge Screw	Llave Torx Clé Torx Torx Wrench	Tornillo de Fijación Vis de Fixation Mounting Screw						
AFM88C-SN12..-D050-A22-Z05-H	●	50	5	22	40	11.5	SN.. 12..						2508-M10x30					
AFM88C-SN12..-D063-A22-Z06-H	●	63	6	22	40	11.5								1015-M4x11	ACK-05	4015-M4x11	80-T15	2510-M12x35
AFM88C-SN12..-D080-A27-Z07-H	●	80	7	27	50	11.5												2514-M16x35
AFM88C-SN12..-D100-A32-Z09-H	●	100	9	32	52	11.5												

R: Derecha / Droite / Right L: Izquierda / Gauche / Left

● En Existencia / En stock / In Stock ○ Artículo sin Existencia / Indisponible en Stock / Non Stock Item
Compatible con el Inserto ISO. / Compatible avec ISO Plaquettes. / Compatible with ISO Insert.

Ejemplo de Pedido / Exemple de Commande / Ordering Example

1 Piezas / pcs. / pcs. AFM88C-SN1206-D063-A22-Z06-H

Cálculo de Corte : S 369 / Calcul de Coupe : P 369 / Cutting Calculation : 369

Referencia de Montaje : S 366 / Montage Référence : P 366 / Mounting Specifications : 366

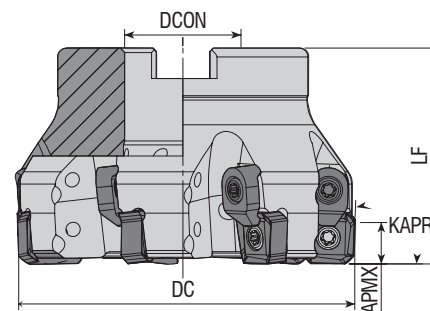

Código del Inserto Le Code de Commande Ordering Code	Stock Stock	Dimension (mm) Dimension (mm) Dimension (mm)					Inserto Plaquette Insert	Tornillo Vis Screw	Abrazadera de Cuñas Mode de Fixation Wedge Clamp	Tornillo de Sujeción Vis de Fixation Wedge Screw	Llave Torx Clé Torx Torx Wrench	Tornillo de Fijación Vis de Fixation Mounting Screw
		DC	ZEFP	DCON	LF	APMX						
AFM88C-SN12Z-D063-A22-Z06-H	●	63	6	22	40	11.5	SNEG 1205..	4015-M4x11	ACK-05	4015-M4X11	80-T15	2508-M10x30
AFM88C-SN12Z-D080-A27-Z07-H	●	80	7	27	50	11.5						2510-M12x35

Compatible con el Inserto ZCC. / Compatible avec ZCC Plaquettes. / Compatible with ZCC Insert.

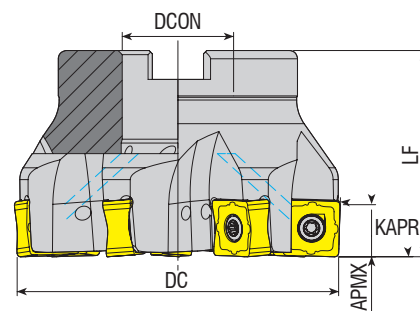

Código del Inserto Le Code de Commande Ordering Code	Stock Stock	Dimension (mm) Dimension (mm) Dimension (mm)					Inserto Plaquette Insert	Tornillo Vis Screw	Abrazadera de Cuñas Mode de Fixation Wedge Clamp	Tornillo de Sujeción Vis de Fixation Wedge Screw	Llave Torx Clé Torx Torx Wrench	Tornillo de Fijación Vis de Fixation Mounting Screw
		DC	ZEFP	DCON	LF	APMX						
AFM89-SN1305I-D040-A16-Z04-H	●	40	4	16	40	10	SNUMU 1305..	1015 M4x11		80-T15	2306-M8x37	
AFM89-SN1305I-D050-A22-Z05-H	●	50	5	22	40	10					2508-M10x30	
AFM89-SN1305I-D063-A22-Z06-H	●	63	6	22	40	10	SNUMU 1305.. OXMT 0507..			80-T15	2510-M12x35	
AFM89-SN1305I-D063-A22-Z07-H	●	63	7	22	40	10					2514-M16x35	
AFM89-SN1305I-D080-A27-Z08-H	●	80	8	27	50	10						
AFM89-SN1305I-D100-A32-Z10-H	●	100	10	32	50	10						

R: Derecha / Droite / Right L: Izquierda / Gauche / Left

● En Existencia / En stock / In Stock ○ Artículo sin Existencia / Indisponible en Stock / Non Stock Item
Compatible con el Inserto ISCR. / Compatible avec ISCR Plaquettes. / Compatible with ISCR Insert.

Ejemplo de Pedido / Exemple de Commande / Ordering Example

1 Piezas / pcs. / pcs. AFM88C-SN12Z-D063-A22-Z06-H

Cálculo de Corte : S 369 / Calcul de Coupe : P 369 / Cutting Calculation : 369

Referencia de Montaje : S 366 / Montage Référence : P 366 / Mounting Specifications : 366

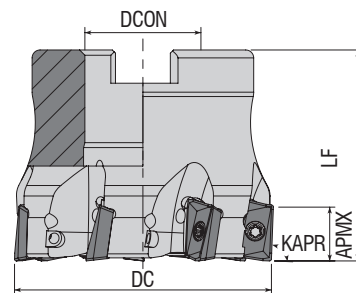

Código del Inserto Le Code de Commande Ordering Code	Stock Stock Stock	Dimension (mm) Dimension (mm) Dimension (mm)					Inserto Plaquette Insert	Recambios / Pièces de Rechange / Spare Parts		
		DC	ZEPF	DCON	LF	APMX		Tornillo Vis Screw	Llave Torx Clé Torx Torx Wrench	Tornillo de Fijación Vis de Fixation Mounting Screw
AFM90-AD10T3-D040-A16-Z06-H	●	40	6	16	40	10	ADMT 10T3..			
AFM90-AD10T3-D050-A22-Z07-H	●	50	7	22	40	10				

Compatible con el Inserto WLTR. / Compatible avec WLTR Plaquettes. / Compatible with WLTR Insert.

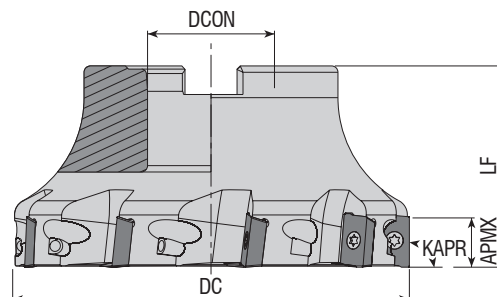

Código del Inserto Le Code de Commande Ordering Code	Stock Stock Stock	Dimension (mm) Dimension (mm) Dimension (mm)					Inserto Plaquette Insert	Recambios / Pièces de Rechange / Spare Parts					
		DC	ZEPF	DCON	LF	APMX		Tornillo Vis Screw	Llave Torx Clé Torx Torx Wrench	Tornillo de Fijación Vis de Fixation Mounting Screw			
AFM90-AD1505-D040-A16-Z04-H	●	40	4	16	40	14.3	AD.. 1505..						
AFM90-AD1505-D050-A22-Z05-H	●	50	5	22	40	14.3					4015-M4x11	80-T15	2506-M8x30
AFM90-AD1505-D063-A22-Z06-H	●	63	6	22	40	14.3					2508-M10x30		
AFM90-AD1505-D080-A27-Z07-H	●	80	7	27	50	14.3					2510-M12x35		
AFM90-AD1505-D100-A32-Z08-H	●	100	8	32	50	14.3					2514-M16x35		
AFM90-AD1505-D125-B40-Z09	●	125	9	40	63	14.3					-		

R: Derecha / Droite / Right L: Izquierda / Gauche / Left

● En Existencia / En stock / In Stock ○ Artículo sin Existencia / Indisponible en Stock / Non Stock Item
Compatible con el Inserto ISCR. / Compatible avec ISCR Plaquettes. / Compatible with ISCR Insert.

Ejemplo de Pedido / Exemple de Commande / Ordering Example

1 Piezas / pcs. / pcs. AFM90-AD10T3-D040-A16-Z06-H

Cálculo de Corte : S 369 / Calcul de Coupe : P 369 / Cutting Calculation : 369

Referencia de Montaje : S 366 / Montage Référence : P 366 / Mounting Specifications : 366

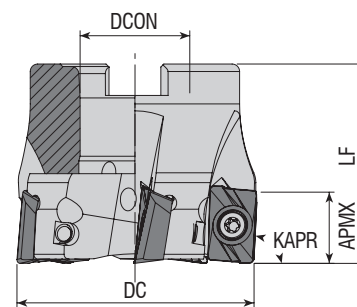

Código del Inserto Le Code de Commande Ordering Code	Stock Stock	Dimension (mm) Dimension (mm) Dimension (mm)					Inserto Plaquette Insert	Recambios / Pièces de Rechange / Spare Parts		
		DC	ZEP	DCON	LF	APMX		Tornillo Vis Screw	Llave Torx Clé Torx Torx Wrench	Tornillo de Fijación Vis de Fixation Mounting Screw
AFM90-AD1505D-D050-A22-Z05-H	●	50	5	22	40	14.3	ADKT 150508	4015-M4x11	80-T15	2508-M10x30
AFM90-AD1505D-D063-A27-Z06-H	●	63	6	27	50	14.3				2510-M12x35
AFM90-AD1505D-D080-A27-Z08-H	●	80	8	27	50	14.3				2514-M16x35
AFM90-AD1505D-D100-A32-Z08-H	●	100	8	32	50	14.3				-
AFM90-AD1505D-D125-B40-Z09	●	125	9	40	63	14.3				-

Compatible con el Inserto DJT. / Compatible avec DJT Plaquettes. / Compatible with DJT Insert.

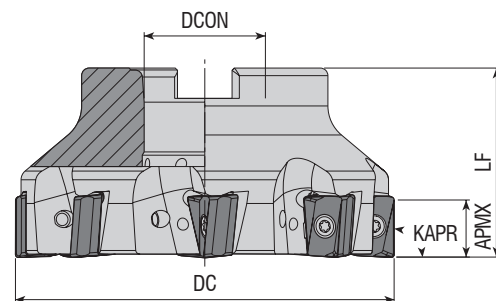

Código del Inserto Le Code de Commande Ordering Code	Stock Stock	Dimension (mm) Dimension (mm) Dimension (mm)					Inserto Plaquette Insert	Recambios / Pièces de Rechange / Spare Parts		
		DC	ZEP	DCON	LF	APMX		Tornillo Vis Screw	Llave Torx Clé Torx Torx Wrench	Tornillo de Fijación Vis de Fixation Mounting Screw
AFM90-AN11-D040-A16-Z04-H	●	40	4	16	40	11	ANGX 1105..	4010-M3x8	80-T10	2506-M8x30
AFM90-AN1506-D050-A22-Z04-H	●	50	4	22	40	14.5				2508-M10x30
AFM90-AN1506-D063-A22-Z05-H	●	63	5	22	40	14.5	ANGX 1506..	4015-M4x12	80-T15	2510-M12x35
AFM90-AN1506-D080-A27-Z06-H	●	80	6	27	50	14.5				2514-M16x35
AFM90-AN1506-D100-A32-Z08-H	●	100	8	32	50	14.5				-
AFM90-AN1506-D125-B40-Z09	●	125	9	40	63	14.5				-
AFM90-AN1506-D160-C40-Z10	●	160	10	40	63	14.5	-	-	-	

R: Derecha / Droite / Right L: Izquierda / Gauche / Left

● En Existencia / En stock / In Stock ○ Artículo sin Existencia / Indisponible en Stock / Non Stock Item
Compatible con el Inserto ZCC. / Compatible avec ZCC Plaquettes. / Compatible with ZCC Insert.

Ejemplo de Pedido / Exemple de Commande / Ordering Example

1 Piezas / pcs. / pcs. AFM90-AD1505D-D050-A22-Z05-H

Cálculo de Corte : S 369 / Calcul de Coupe : P 369 / Cutting Calculation : 369

Referencia de Montaje : S 366 / Montage Référence : P 366 / Mounting Specifications : 366

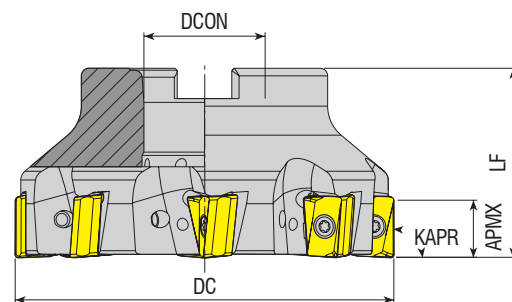

Código del Inserto Le Code de Commande Ordering Code	Stock Stock Stock	Dimension (mm) Dimension (mm) Dimension (mm)					Inserto Plaquette Insert	Recambios / Pièces de Rechange / Spare Parts			
		DC	ZEFP	DCON	LF	APMX		Tornillo Vis Screw	Llave Torx Clé Torx Torx Wrench	Tornillo de Fijación Vis de Fixation Mounting Screw	
AFM90-AN1607-D050-A22-Z04-H	●	50	4	22	40	15	AN.X 1607..				
AFM90-AN1607-D063-A22-Z06-H	●	63	6	22	40	15					
AFM90-AN1607-D080-A27-Z07-H	●	80	7	27	50	15					2510-M12x35
AFM90-AN1607-D100-A32-Z08-H	●	100	8	32	50	15					2514-M16x35
AFM90-AN1607-D125-B40-Z10	●	125	10	40	63	15					-

Compatible con el Inserto TGTC. / Compatible avec TGTC Plaquettes. / Compatible with TGTC Insert.

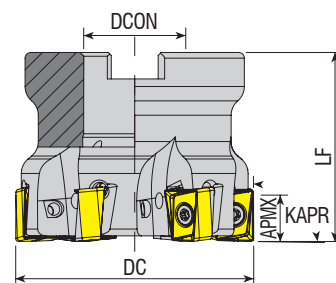

Código del Inserto Le Code de Commande Ordering Code	Stock Stock Stock	Dimension (mm) Dimension (mm) Dimension (mm)					Inserto Plaquette Insert	Recambios / Pièces de Rechange / Spare Parts			
		DC	ZEFP	DCON	LF	APMX		Tornillo Vis Screw	Llave Torx Clé Torx Torx Wrench	Tornillo de Fijación Vis de Fixation Mounting Screw	
AFM90-AN12-D040-A16-Z04-H	●	40	4	16	40	12	ANKX 1205..				
AFM90-AN12-D050-A22-Z05-H	●	50	5	22	40	12					2406-M8x30
AFM90-AN12-D063-A27-Z06-H	●	63	6	27	50	12					2508-M10x30 2510-M12x35

R: Derecha / Droite / Right L: Izquierda / Gauche / Left

● En Existencia / En stock / In Stock ○ Artículo sin Existencia / Indisponible en Stock / Non Stock Item
Compatible con el Inserto ISCR. / Compatible avec ISCR Plaquettes. / Compatible with ISCR Insert.

Ejemplo de Pedido / Exemple de Commande / Ordering Example

1 Piezas / pcs. / pcs. AFM90-AN1607-D050-A22-Z04-H

Cálculo de Corte : S 369 / Calcul de Coupe : P 369 / Cutting Calculation : 369

Referencia de Montaje : S 366 / Montage Référence : P 366 / Mounting Specifications : 366

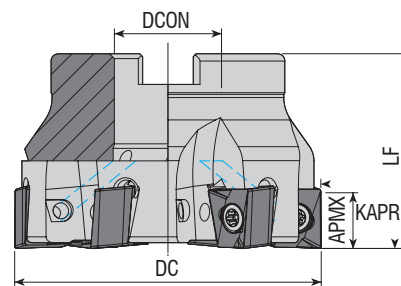

Código del Inserto Le Code de Commande Ordering Code	Stock Stock Stock	Dimension (mm) Dimension (mm) Dimension (mm)					Inserto Plaquette Insert	Recambios / Pièces de Rechange / Spare Parts		
		DC	ZEPF	DCON	LF	APMX		Tornillo Vis Screw	Llave Torx Clé Torx Torx Wrench	Tornillo de Fijación Vis de Fixation Mounting Screw
AFM90-AN1207-D040-A16-Z04-H	●	40	4	16	40	10	ANKX 1207..	4015-M4x11	80-T15	2506-M8x30
AFM90-AN1207-D050-A22-Z05-H	●	50	5	22	40	10				2508-M10x30
AFM90-AN1207-D063-A22-Z06-H	●	63	6	22	40	10				2510-M12x35
AFM90-AN1607X-D050-A22-Z04-H	●	50	4	22	40	15	ANKX 1607..	4015-M4x11	80-T15	2508-M10x30
AFM90-AN1607X-D063-A22-Z06-H	●	63	6	22	40	15				2510-M12x35
AFM90-AN1607X-D080-A27-Z07-H	●	80	7	27	50	15				

Compatible con el Inserto XTC-GSC. / Compatible avec XTC-GSC Plaquettes. / Compatible with XTC-GSC Insert.

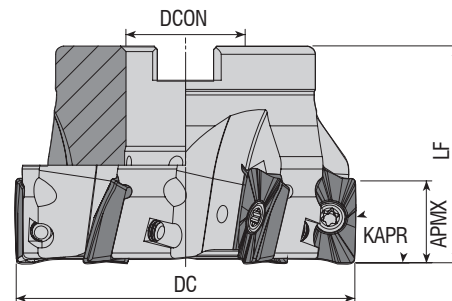

Código del Inserto Le Code de Commande Ordering Code	Stock Stock Stock	Dimension (mm) Dimension (mm) Dimension (mm)					Inserto Plaquette Insert	Recambios / Pièces de Rechange / Spare Parts		
		DC	ZEPF	DCON	LF	APMX		Tornillo Vis Screw	Llave Torx Clé Torx Torx Wrench	Tornillo de Fijación Vis de Fixation Mounting Screw
AFM90-A01236-D050-A22-Z05-H	●	50	5	22	40	10	AO.. 1236..	3008-M2.5x6	80-T08	2508-M10x30
AFM90-A01848-D050-A22-Z05-H	●	50	5	22	40	15	AO.. 1848..	4015-M4x11	80-T15	
AFM90-A01848-D063-A22-Z06-H	●	63	6	22	40	15				

R: Derecha / Droite / Right L: Izquierda / Gauche / Left

● En Existencia / En stock / In Stock ○ Artículo sin Existencia / Indisponible en Stock / Non Stock Item
Compatible con el Inserto MTSBH. / Compatible avec MTSBH Plaquettes. / Compatible with MTSBH Insert.

Ejemplo de Pedido / Exemple de Commande / Ordering Example

1 Piezas / pcs. / pcs. AFM90-AN1207-D040-A16-Z04-H

Cálculo de Corte : S 369 / Calcul de Coupe : P 369 / Cutting Calculation : 369

Referencia de Montaje : S 366 / Montage Référence : P 366 / Mounting Specifications : 366

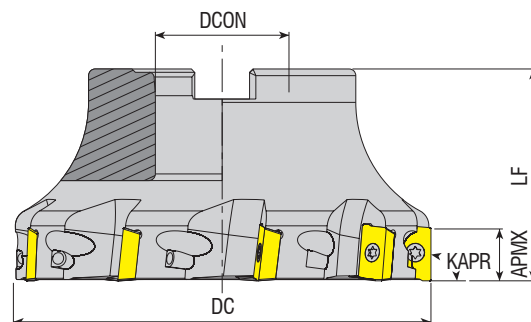

Código del Inserto Le Code de Commande Ordering Code	Stock Stock	Dimension (mm) Dimension (mm)					Inserto Plaquette Insert	Recambios / Pièces de Rechange / Spare Parts					
		DC	ZEFP	DCON	LF	APMX		Tornillo Vis Screw	Llave Torx Clé Torx Torx Wrench	Tornillo de Fijación Vis de Fixation Mounting Screw			
AFM90-AP10-D040-A16-Z05-H	●	40	5	16	40	10	AP. 1003.. Compatible con el Inserto ISO. Compatible avec ISO Plaquettes. FOR ISO INSERT.	3008-M2.5x6	80-T08	2506-M8x30			
AFM90-AP10-D050-A22-Z06-H	●	50	6	22	40	10				2508-M10x30			
AFM90-AP10-D063-A22-Z07-H	●	63	7	22	40	10				2510-M12x35			
AFM90-AP10-D080-A27-Z08-H	●	80	8	27	50	10				2514-M16x35			
AFM90-AP10-D100-A32-Z09-H	●	100	9	32	50	10				2506-M8x30			
AFM90-AP16-D040-A16-Z04-H	●	40	4	16	40	16	AP. 1604.. Compatible con el Inserto ISO. Compatible avec ISO Plaquettes. FOR ISO INSERT.	4015-M4x11	80-T15	2508-M10x30			
AFM90-AP16-D050-A22-Z05-H	●	50	5	22	40	16				2510-M12x35			
AFM90-AP16-D052-A22-Z05-H	●	52	5	22	40	16				2514-M16x35			
AFM90-AP16-D063-A22-Z06-H	●	63	6	22	40	16				-			
AFM90-AP16-D080-A27-Z07-H	●	80	7	27	50	16				2506-M8x30			
AFM90-AP16-D100-A32-Z08-H	●	100	8	32	50	16				2508-M10x30			
AFM90-AP16-D125-B40-Z09	●	125	9	40	63	16				2510-M12x35			
AFM90-AP16-D160-C40-Z10	●	160	10	40	63	16				2514-M16x35			
AFM90-AP16-D200-C60-Z12	●	200	12	60	63	16				-			
AFM90-AP16DJ-D050-A22-Z05-H	●	50	5	22	40	16				AP. 1604.. Compatible con el Inserto DJT. Compatible avec DJT Plaquettes. FOR DJT INSERT.	4015-M4x11	80-T15	2508-M10x30
AFM90-AP16DJ-D063-A22-Z06-H	●	63	6	22	40	16							2510-M12x35
AFM90-AP16DJ-D080-A27-Z07-H	●	80	7	27	50	16							2506-M8x30
AFM90-AP16L-D050-A22-Z05-H	●	50	5	22	40	16	AP. 1604.. Para Inserto LMN. POUR LMN PLAQUETTES. FOR LMN INSERT.	4015-M4x11	80-T15	2508-M10x30			
AFM90-AP16L-D063-A22-Z06-H	●	63	6	22	40	16				2510-M12x35			
AFM90-AP16L-D080-A27-Z07-H	●	80	7	27	50	16				2506-M8x30			
AFM90-AP16P-D040-A16-Z04-H	●	40	4	16	40	16				2508-M10x30			
AFM90-AP16P-D050-A22-Z05-H	●	50	5	22	40	16				2510-M12x35			
AFM90-AP16P-D063-A22-Z06-H	●	63	6	22	40	16	AP. 1604.. Compatible con el Inserto PLBT. Compatible avec PLBT Plaquettes. FOR PLBT INSERT.	4015-M4x11	80-T15	2514-M16x35			
AFM90-AP16P-D080-A27-Z07-H	●	80	7	27	50	16				2506-M8x30			
AFM90-AP16P-D100-A32-Z08-H	●	100	8	32	50	16	AP. 1604.. Compatible con el Inserto ACTKH. Compatible avec ACTKH Plaquettes. FOR ACTKH INSERT.	4015-M4x11	80-T15	2508-M10x30			
AFM90-AP16A-D050-A22-Z05-H	●	50	5	22	40	15				2510-M12x35			
AFM90-AP16A-D063-A22-Z06-H	●	63	6	22	40	15				2514-M16x35			
AFM90-AP16A-D080-A27-Z07-H	●	80	7	27	50	15				-			
AFM90-AP16A-D100-A32-Z08-H	●	100	8	32	50	15				2506-M8x30			
AFM90-AP16Y-D040-A16-Z04-H	●	40	4	16	40	16	AP. 1604.. Compatible con el Inserto YG. Compatible avec YG Plaquettes. FOR YG INSERT.	4015-M4x11	80-T15	2508-M10x30			
AFM90-AP16Y-D050-A22-Z05-H	●	50	5	22	40	16				2510-M12x35			
AFM90-AP16Y-D063-A22-Z06-H	●	63	6	22	40	16				2514-M16x35			
AFM90-AP16Y-D080-A27-Z07-H	●	80	7	27	50	16				-			
AFM90-AP16Y-D100-A32-Z08-H	●	100	8	32	50	16				2506-M8x30			

R: Derecha / Droite / Right L: Izquierda / Gauche / Left

● En Existencia / En stock / In Stock ○ Artículo sin Existencia / Indisponible en Stock / Non Stock Item

Ejemplo de Pedido / Exemple de Commande / Ordering Example

1 Piezas / pcs. / pcs. AFM90-AP10-D040-A16-Z05-H

Cálculo de Corte : S 369 / Calcul de Coupe : P 369 / Cutting Calculation : 369

Referencia de Montaje : S 366 / Montage Référence : P 366 / Mounting Specifications : 366

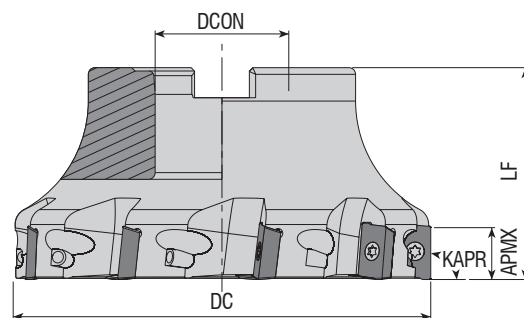
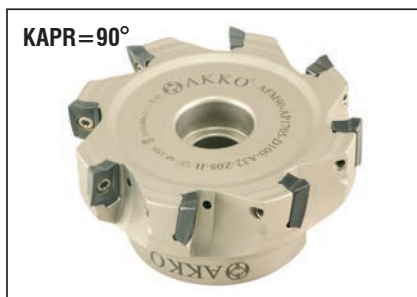

Código del Inserto Le Code de Commande Ordering Code	Stock Stock	Dimension (mm) Dimension (mm) Dimension (mm)					Inserto Plaquette Insert	Recambios / Pièces de Rechange / Spare Parts		
		DC	ZFP	DCON	LF	APMX		Tornillo Vis Screw	Llave Torx Clé Torx Torx Wrench	Tornillo de Fijación Vis de Fixation Mounting Screw
AFM90-AP1705-D050-A22-Z05-H	●	50	5	22	40	16	AP. 1705..	4015-M4x11	80-T15	2508-M10x30
AFM90-AP1705-D063-A22-Z06-H	●	63	6	22	40	16				2510-M12x35
AFM90-AP1705-D080-A27-Z07-H	●	80	7	27	50	16				2514-M16x35
AFM90-AP1705-D100-A32-Z08-H	●	100	8	32	50	16				

Compatible con el Inserto TGTC. / Compatible avec TGTC Plaquettes. / Compatible with TGTC Insert.

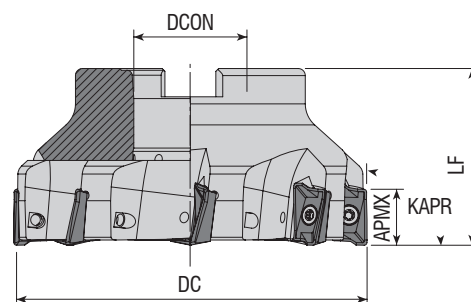
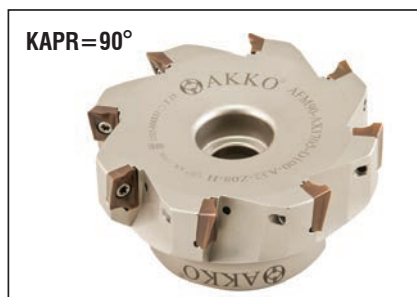

Código del Inserto Le Code de Commande Ordering Code	Stock Stock	Dimension (mm) Dimension (mm) Dimension (mm)					Inserto Plaquette Insert	Recambios / Pièces de Rechange / Spare Parts		
		DC	ZFP	DCON	LF	APMX		Tornillo Vis Screw	Llave Torx Clé Torx Torx Wrench	Tornillo de Fijación Vis de Fixation Mounting Screw
AFM90-AX1235-D040-A16-Z06-H	●	40	6	16	40	10	AX.T 1235..	3108-M3x6	80-T08	2506-M8x30
AFM90-AX1235-D050-A22-Z07-H	●	50	7	22	40	10				2508-M10x30
AFM90-AX1235-D063-A22-Z08-H	●	63	8	22	40	10				2510-M12x35
AFM90-AX1235-D080-A27-Z10-H	●	80	10	27	50	10				2514-M16x35
AFM90-AX1705-D040-A16-Z04-H	●	40	4	16	40	14	AX.T 1705..	4015-M4x11	80-T15	2506-M8x30
AFM90-AX1705-D050-A22-Z05-H	●	50	5	22	40	14				2508-M10x30
AFM90-AX1705-D063-A22-Z06-H	●	63	6	22	40	14				2510-M12x35
AFM90-AX1705-D080-A27-Z07-H	●	80	7	27	50	14				2514-M16x35
AFM90-AX1705-D100-A32-Z08-H	●	100	8	32	50	14				

R: Derecha / Droite / Right L: Izquierda / Gauche / Left

● En Existencia / En stock / In Stock ○ Artículo sin Existencia / Indisponible en Stock / Non Stock Item

Compatible con el Inserto SMTM. / Compatible avec SMTM Plaquettes. / Compatible with SMTM Insert.

Ejemplo de Pedido / Exemple de Commande / Ordering Example

1 Piezas / pcs. / pcs. AFM90-AP1705-D050-A22-Z05-H

Cálculo de Corte : S 369 / Calcul de Coupe : P 369 / Cutting Calculation : 369

Referencia de Montaje : S 366 / Montage Référence : P 366 / Mounting Specifications : 366

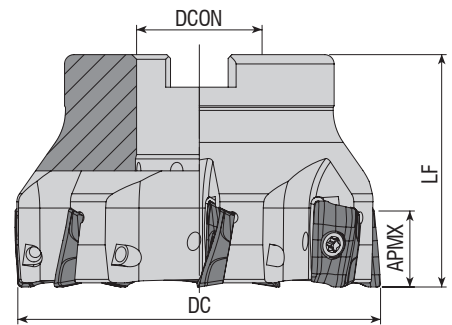

Código del Inserto Le Code de Commande Ordering Code	Stock Stock Stock	Dimension (mm) Dimension (mm) Dimension (mm)					Inserto Plaquette Insert	Recambios / Pièces de Rechange / Spare Parts		
		DC	ZEPF	DCON	LF	APMX		Tornillo Vis Screw	Llave Torx Clé Torx Torx Wrench	Tornillo de Fijación Vis de Fixation Mounting Screw
AFM90-BD11T3-D040-A16-Z04-H	●	40	4	16	40	10	BDMT 11T3..	3008-M2.5x6	80-T08	2506-M8x30
AFM90-BD11T3-D040-A16-Z05-H	●	40	5	16	40	10				
AFM90-BD11T3-D050-A22-Z05-H	●	50	5	22	40	10				
AFM90-BD11T3-D063-A22-Z06-H	●	63	6	22	40	10				
AFM90-BD1704-D050-A22-Z04-H	●	50	4	22	40	15.7	BDMT 1704..	4015-M4x11	80-T15	2508-M10x30
AFM90-BD1704-D050-A22-Z05-H	●	50	5	22	40	15.7				
AFM90-BD1704-D063-A22-Z06-H	●	63	6	22	40	15.7				
AFM90-BD1704-D080-A27-Z06-H	●	80	6	27	50	15.7				
AFM90-BD1704-D080-A27-Z07-H	●	80	7	27	50	15.7				
AFM90-BD1704-D100-A32-Z07-H	●	100	7	32	50	15.7				

Compatible con el Inserto KYGR. / Compatible avec KYGR Plaquettes. / Compatible with KYGR Insert.

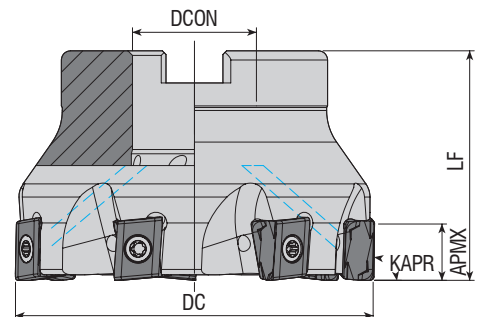

Código del Inserto Le Code de Commande Ordering Code	Stock Stock Stock	Dimension (mm) Dimension (mm) Dimension (mm)					Inserto Plaquette Insert	Recambios / Pièces de Rechange / Spare Parts		
		DC	ZEPF	DCON	LF	APMX		Tornillo Vis Screw	Llave Torx Clé Torx Torx Wrench	Tornillo de Fijación Vis de Fixation Mounting Screw
AFM90-LN1506X-D063-A22-Z06	●	63	6	22	40	7	LNMT 1506..	3015-M4x11	80-T15	2508-M10x30
AFM90-LN1506X-D080-A27-Z07	●	80	7	27	50	7				2510-M12x35
AFM90-LN1506X-D100-A32-Z08	●	100	8	32	50	7				2514-M16x35

R: Derecha / Droite / Right L: Izquierda / Gauche / Left

● En Existencia / En stock / In Stock ○ Artículo sin Existencia / Indisponible en Stock / Non Stock Item

Compatible con el Inserto XTC-GSC. / Compatible avec XTC-GSC Plaquettes. / Compatible with XTC-GSC Insert.

Ejemplo de Pedido / Exemple de Commande / Ordering Example

1 Piezas / pcs. / pcs. AFM90-BD11T3-D040-A16-Z04-H

Cálculo de Corte : S 369 / Calcul de Coupe : P 369 / Cutting Calculation : 369

Referencia de Montaje : S 366 / Montage Référence : P 366 / Mounting Specifications : 366

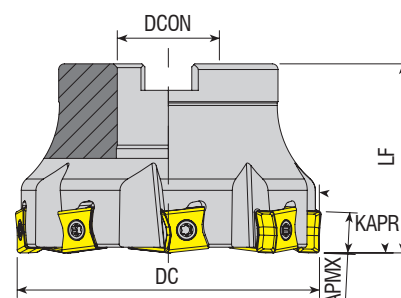

Código del Inserto Le Code de Commande Ordering Code	Stock Stock Stock	Dimension (mm) Dimension (mm) Dimension (mm)					Inserto Plaquette Insert	Recambios / Pièces de Rechange / Spare Parts		
		DC	ZEFP	DCON	LF	APMX		Tornillo Vis Screw	Llave Torx Clé Torx Torx Wrench	Tornillo de Fijación Vis de Fixation Mounting Screw
AFM90-LN1106-D050-A22-Z05	●	50	5	22	40	10	LNMT 1106..	4015-M3.5x11	80-T15	2508-M10x30
AFM90-LN1106-D063-A22-Z06	●	63	6	22	40	10				2510-M12x35
AFM90-LN1106-D080-A27-Z08	●	80	8	27	50	10				2514-M16x35
AFM90L-LN1106-D080-A27-Z08	●	80	8	27	50	10				-
AFM90-LN1106-D100-A32-Z09	●	100	9	32	50	10				2506-M8x30
AFM90L-LN1106-D100-A32-Z09	●	100	9	32	50	10				2508-M10x30
AFM90-LN1106-D125-B40-Z10	●	125	10	40	63	10				2510-M12x35
AFM90-LN1306-D040-A16-Z04-H	●	40	4	16	40	12.5	T490 LNMT 1306..	4015-M4x11	80-T15	2514-M16x35
AFM90-LN1306-D050-A22-Z05-H	●	50	5	22	40	12.5				2506-M8x30
AFM90-LN1306-D063-A22-Z06-H	●	63	6	22	40	12.5				2508-M10x30
AFM90-LN1306-D080-A27-Z07-H	●	80	7	27	50	12.5				2510-M12x35
AFM90-LN1306-D100-A32-Z08-H	●	100	8	32	50	12.5				2514-M16x35
AFM90L-LN1506-D040-A16-Z04	○	40	4	16	40	14	LNMT 1506..	4015-M4x11	80-T20	2506-M8x30
AFM90-LN1506-D040-A16-Z04	○	40	4	16	40	14				2508-M10x30
AFM90-LN1506-D050-A22-Z05	○	50	5	22	40	14				2510-M12x35
AFM90-LN1506-D063-A22-Z06	○	63	6	22	40	14				2514-M16x35
AFM90-LN1506-D080-A27-Z07	○	80	7	27	50	14				-
AFM90-LN1607-D050-A22-Z03-H	●	50	3	22	40	16	T490 LNHT 1607..	4420-M5x14	80-T20	2506-M8x30
AFM90-LN1607-D063-A22-Z04-H	○	63	4	22	40	16				2508-M10x30
AFM90-LN1607-D080-A27-Z05-H	●	80	5	27	50	16				2510-M12x35
AFM90-LN1607-D100-A32-Z06-H	●	100	6	32	50	16				2514-M16x35

R: Derecha / Droite / Right L: Izquierda / Gauche / Left
 ● En Existencia / En stock / In Stock ○ Artículo sin Existencia / Indisponible en Stock / Non Stock Item
 Compatible con el Inserto ISCR. / Compatible avec ISCR Plaquettes. / Compatible with ISCR Insert.

Ejemplo de Pedido / Exemple de Commande / Ordering Example
 1 Piezas / pcs. / pcs. AFM90-LN1106-D050-A22-Z05
 Cálculo de Corte : S 369 / Calcul de Coupe : P 369 / Cutting Calculation : 369
 Referencia de Montaje : S 366 / Montage Référence : P 366 / Mounting Specifications : 366

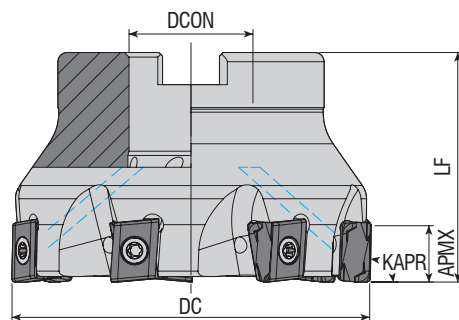

Código del Inserto Le Code de Commande Ordering Code	Stock Stock Stock	Dimension (mm) Dimension (mm) Dimension (mm)					Inserto Plaquette Insert	Recambios / Pièces de Rechange / Spare Parts		
		DC	ZEFP	DCON	LF	APMX		Tornillo Vis Screw	Llave Torx Clé Torx Torx Wrench	Tornillo de Fijación Vis de Fixation Mounting Screw
AFM90-LN1306W-D050-A22-Z05-H	●	50	5	22	40	12	LNHU 1306..	4115-M4x12	80-T15	2508-M10x30
AFM90-LN1306W-D063-A22-Z06-H	●	63	6	22	40	12				2510-M12x35
AFM90-LN1306W-D080-A27-Z07-H	●	80	7	27	50	12				

Compatible con el Inserto WLTR. / Compatible avec WLTR Plaquettes. / Compatible with WLTR Insert.

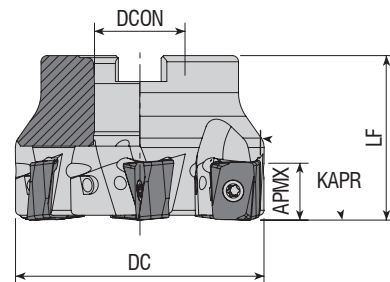

Código del Inserto Le Code de Commande Ordering Code	Stock Stock Stock	Dimension (mm) Dimension (mm) Dimension (mm)					Inserto Plaquette Insert	Recambios / Pièces de Rechange / Spare Parts		
		DC	ZEFP	DCON	LF	APMX		Tornillo Vis Screw	Llave Torx Clé Torx Torx Wrench	Tornillo de Fijación Vis de Fixation Mounting Screw
AFM90-LN1307-D050-A22-Z04-H	●	50	4	22	40	13	LNGX 1307..	1315-M4x11	80-T15	2508-M10x30
AFM90-LN1307-D063-A22-Z06-H	●	63	6	22	40	13				2510-M12x35
AFM90-LN1307-D080-A27-Z07-H	●	80	7	27	50	13				2514-M16x35
AFM90-LN1307-D100-A32-Z08-H	●	100	8	32	50	13				

R: Derecha / Droite / Right L: Izquierda / Gauche / Left

● En Existencia / En stock / In Stock ○ Artículo sin Existencia / Indisponible en Stock / Non Stock Item
Compatible con el Inserto WLTR. / Compatible avec WLTR Plaquettes. / Compatible with WLTR Insert.

Ejemplo de Pedido / Exemple de Commande / Ordering Example

1 Piezas / pcs. / pcs. AFM90-LN1306W-D050-A22-Z05-H

Cálculo de Corte : S 369 / Calcul de Coupe : P 369 / Cutting Calculation : 369

Referencia de Montaje : S 366 / Montage Référence : P 366 / Mounting Specifications : 366

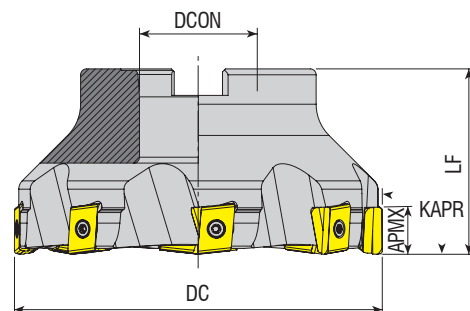

Código del Inserto Le Code de Commande Ordering Code	Stock Stock Stock	Dimension (mm) Dimension (mm) Dimension (mm)					Inserto Plaquette Insert	Recambios / Pièces de Rechange / Spare Parts		
		DC	ZEFP	DCON	LF	APMX		Tornillo Vis Screw	Llave Torx Clé Torx Torx Wrench	Tornillo de Fijación Vis de Fixation Mounting Screw
AFM90-LN15Z-D050-A22-Z04	●	50	4	22	40	15	LNKT 1506..	4015-M4x11	80-T15	2508-M10x30
AFM90-LN15Z-D063-A22-Z05	●	63	5	22	40	15				2510-M12x35
AFM90-LN15Z-D080-A27-Z06	●	80	6	27	50	15				2514-M16x35
AFM90-LN15Z-D100-A32-Z07	●	100	7	32	50	15				-
AFM90-LN15Z-D125-B40-Z08	●	125	8	40	63	15				-

Compatible con el Inserto ZCC. / Compatible avec ZCC Plaquettes. / Compatible with ZCC Insert.

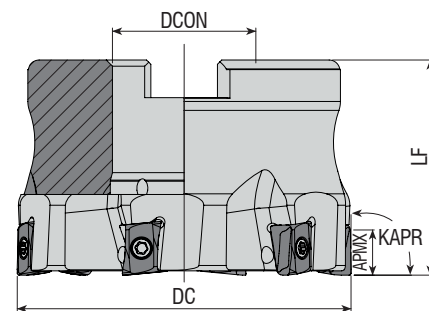

Código del Inserto Le Code de Commande Ordering Code	Stock Stock Stock	Dimension (mm) Dimension (mm) Dimension (mm)					Inserto Plaquette Insert	Recambios / Pièces de Rechange / Spare Parts		
		DC	ZEFP	DCON	LF	APMX		Tornillo Vis Screw	Llave Torx Clé Torx Torx Wrench	Tornillo de Fijación Vis de Fixation Mounting Screw
AFM90-L008-D040-A16-Z06-H	●	40	6	16	40	2	LOEX 0804..	3008-M2.5x8	80-T08	2506-M8x30
AFM90-L008-D050-A22-Z07-H	●	50	7	22	40	2				2508-M10x30
AFM90-L008-D063-A27-Z06-H	●	63	6	27	40	2				2510-M12x35

R: Derecha / Droite / Right L: Izquierda / Gauche / Left

● En Existencia / En stock / In Stock ○ Artículo sin Existencia / Indisponible en Stock / Non Stock Item

Compatible con el Inserto SC. / Compatible avec SC Plaquettes. / Compatible with SC Insert.

Ejemplo de Pedido / Exemple de Commande / Ordering Example

1 Piezas / pcs. / pcs. AFM90-LN15Z-D050-A22-Z04

Cálculo de Corte : S 369 / Calcul de Coupe : P 369 / Cutting Calculation : 369

Referencia de Montaje : S 366 / Montage Référence : P 366 / Mounting Specifications : 366

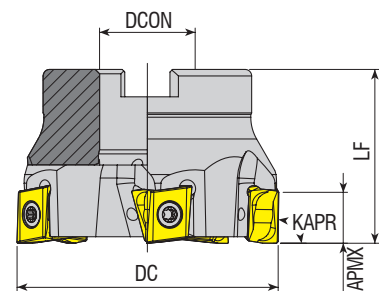

Código del Inserto Le Code de Commande Ordering Code	Stock Stock Stock	Dimension (mm) Dimension (mm) Dimension (mm)					Inserto Plaquette Insert	Recambios / Pièces de Rechange / Spare Parts		
		DC	ZEFP	DCON	LF	APMX		Tornillo Vis Screw	Llave Torx Clé Torx Torx Wrench	Tornillo de Fijación Vis de Fixation Mounting Screw
AFM90-L01207-D040-A16-Z04-H	●	40	4	16	40	11	LOGU 1207..	3015-M4x11	80-T15	2506-M8x30
AFM90-L01207-D050-A22-Z05-H	●	50	5	22	40	11				2508-M10x30
AFM90-L01207-D063-A22-Z05-H	●	63	5	22	40	11				

Compatible con el Inserto MTSBH. / Compatible avec MTSBH Plaquettes. / Compatible with MTSBH Insert.

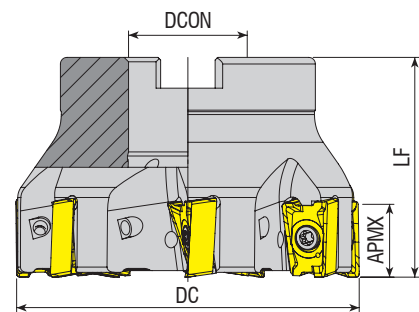

Código del Inserto Le Code de Commande Ordering Code	Stock Stock Stock	Dimension (mm) Dimension (mm) Dimension (mm)					Inserto Plaquette Insert	Recambios / Pièces de Rechange / Spare Parts		
		DC	ZEFP	DCON	LF	APMX		Tornillo Vis Screw	Llave Torx Clé Torx Torx Wrench	Tornillo de Fijación Vis de Fixation Mounting Screw
AFM90-LN15T6-D050-A22-Z05-H	●	50	5	22	40	15.5	LNGU 15T6..	4015-M4x12	80-T15	2508-M10x30
AFM90-LN15T6-D063-A22-Z06-H	●	63	6	22	40	15.5				2510-M12x35
AFM90-LN15T6-D080-A27-Z07-H	●	80	7	27	50	15.5				

R: Derecha / Droite / Right L: Izquierda / Gauche / Left

● En Existencia / En stock / In Stock ○ Artículo sin Existencia / Indisponible en Stock / Non Stock Item
Compatible con el Inserto KNMTL. / Compatible avec KNMTL Plaquettes. / Compatible with KNMTL Insert.

Ejemplo de Pedido / Exemple de Commande / Ordering Example

1 Piezas / pcs. / pcs. AFM90-L01207-D040-A16-Z04-H

Cálculo de Corte : S 369 / Calcul de Coupe : P 369 / Cutting Calculation : 369

Referencia de Montaje : S 366 / Montage Référence : P 366 / Mounting Specifications : 366

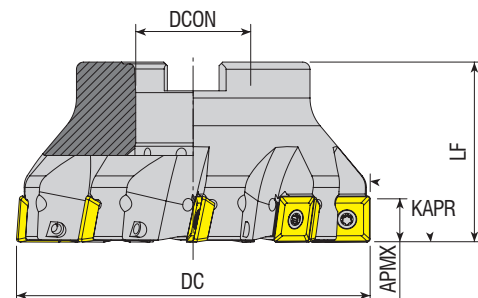

Código del Inserto Le Code de Commande Ordering Code	Stock Stock Stock	Dimension (mm) Dimension (mm) Dimension (mm)					Inserto Plaquette Insert	Recambios / Pièces de Rechange / Spare Parts		
		DC	ZEFP	DCON	LF	APMX		Tornillo Vis Screw	Llave Torx Clé Torx Torx Wrench	Tornillo de Fijación Vis de Fixation Mounting Screw
AFM90-R290.12-D050-A22-Z04-H	●	50	4	22	40	10.7	R290-12T3..	4015-M3.5x11	80-T15	2508-M10x30
AFM90-R290.12-D063-A22-Z05-H	●	63	5	22	40	10.7				2510-M12x35
AFM90-R290.12-D080-A27-Z07-H	●	80	7	27	50	10.7				2514-M16x35
AFM90-R290.12-D100-A32-Z09-H	●	100	9	32	50	10.7				-
AFM90-R290.12-D125-B40-Z11	●	125	11	40	63	10.7				-

Compatible con el Inserto SNDVK. / Compatible avec SNDVK Plaquettes. / Compatible with SNDVK Insert.

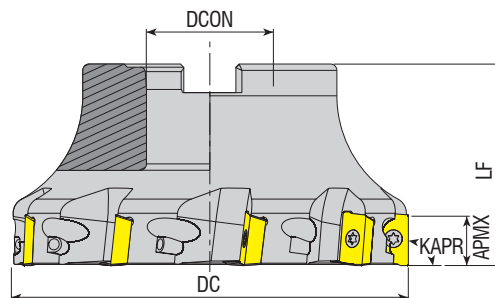

Código del Inserto Le Code de Commande Ordering Code	Stock Stock Stock	Dimension (mm) Dimension (mm) Dimension (mm)					Inserto Plaquette Insert	Recambios / Pièces de Rechange / Spare Parts		
		DC	ZEFP	DCON	LF	APMX		Tornillo Vis Screw	Llave Torx Clé Torx Torx Wrench	Tornillo de Fijación Vis de Fixation Mounting Screw
AFM90-R390.11-D040-A16-Z05-H	●	40	5	16	40	10	R390-11T3..	3008-M2.5x6	80-T08	2506-M8x30
AFM90-R390.11-D050-A22-Z06-H	●	50	6	22	40	10				2508-M10x30
AFM90-R390.11-D063-A22-Z07-H	●	63	7	22	40	10				2510-M12x35
AFM90-R390.11-D080-A27-Z09-H	●	80	9	27	50	10	R390-1704..	4015-M3.5x11	80-T15	2506-M8x30
AFM90-R390.17-D040-A16-Z04-H	●	40	4	16	40	15.4				2508-M10x30
AFM90-R390.17-D050-A22-Z05-H	●	50	5	22	40	15.4				2510-M12x35
AFM90-R390.17-D063-A22-Z06-H	●	63	6	22	40	15.4				2514-M16x35
AFM90-R390.17-D080-A27-Z07-H	●	80	7	27	50	15.4				-
AFM90-R390.17-D100-A32-Z08-H	●	100	8	32	50	15.4				2508-M10x30
AFM90-R390.17-D125-B40-Z09	●	125	9	40	63	15.4				2510-M12x35
AFM90-R390.18-D050-A22-Z04-H	●	50	4	22	40	15.4				2514-M16x35
AFM90-R390.18-D063-A22-Z05-H	●	63	5	22	40	15.4				-
AFM90-R390.18-D080-A27-Z06-H	●	80	6	27	50	15.4	R390-1806..	4015-M4x11	2508-M10x30	
AFM90-R390.18-D100-A32-Z07-H	●	100	7	32	50	15.4			2510-M12x35	
AFM90-R390.18-D125-B40-Z08	●	125	8	40	63	15.4			2514-M16x35	

R: Derecha / Droite / Right L: Izquierda / Gauche / Left

● En Existencia / En stock / In Stock ○ Artículo sin Existencia / Indisponible en Stock / Non Stock Item
Compatible con el Inserto SNDVK. / Compatible avec SNDVK Plaquettes. / Compatible with SNDVK Insert.

Ejemplo de Pedido / Exemple de Commande / Ordering Example

1 Piezas / pcs. / pcs. AFM90-R290.12-D050-A22-Z04-H

Cálculo de Corte : S 369 / Calcul de Coupe : P 369 / Cutting Calculation : 369

Referencia de Montaje : S 366 / Montage Référence : P 366 / Mounting Specifications : 366

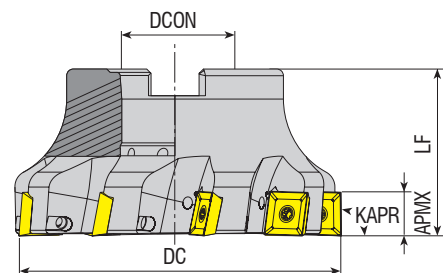

Código del Inserto Le Code de Commande Ordering Code	Stock Stock	Dimension (mm) Dimension (mm)					Inserto Plaqueette Insert	Recambios / Pièces de Rechange / Spare Parts		
		DC	ZEFP	DCON	LF	APMX		Tornillo Vis Screw	Llave Torx Clé Torx Torx Wrench	Tornillo de Fijación Vis de Fixation Mounting Screw
AFM90-490R08-D063-A22-Z06-H	●	63	6	22	40	5.5				
AFM90-490R14-D050-A22-Z04-H	●	50	4	22	40	10				
AFM90-490R14-D063-A22-Z05-H	●	63	5	22	40	10				
AFM90-490R14-D080-A27-Z07-H	●	80	7	27	50	10				
AFM90-490R14-D100-A32-Z07-H	●	100	7	32	50	10				
AFM90-490R14-D125-B40-Z08	●	125	8	40	63	10				
AFM90-490R14-D160-C40-Z12	●	160	12	40	63	10				
AFM90-490R14-D200-C60-Z16	●	200	16	60	63	10				

Compatible con el Inserto SNDVK. / Compatible avec SNDVK Plaquettes. / Compatible with SNDVK Insert.

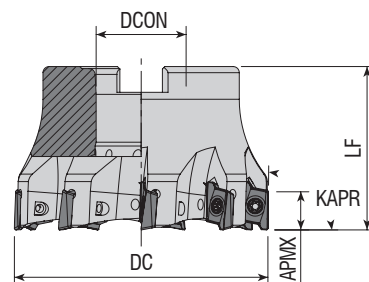

Código del Inserto Le Code de Commande Ordering Code	Stock Stock	Dimension (mm) Dimension (mm)					Inserto Plaqueette Insert	Recambios / Pièces de Rechange / Spare Parts		
		DC	ZEFP	DCON	LF	APMX		Tornillo Vis Screw	Llave Torx Clé Torx Torx Wrench	Tornillo de Fijación Vis de Fixation Mounting Screw
AFM90-RT10-D040-A16-Z06-H	●	40	6	16	40	10				
AFM90-RT10-D050-A22-Z07-H	●	50	7	22	40	10				
AFM90-RT10-D063-A22-Z09-H	●	63	9	22	40	10				

R: Derecha / Droite / Right L: Izquierda / Gauche / Left

● En Existencia / En stock / In Stock ○ Artículo sin Existencia / Indisponible en Stock / Non Stock Item
Compatible con el Inserto SFTY. / Compatible avec SFTY Plaquettes. / Compatible with SFTY Insert.

Ejemplo de Pedido / Exemple de Commande / Ordering Example

1 Piezas / pcs. / pcs. AFM90-490R08-D063-A22-Z06-H

Cálculo de Corte : S 369 / Calcul de Coupe : P 369 / Cutting Calculation : 369

Referencia de Montaje : S 366 / Montage Référence : P 366 / Mounting Specifications : 366

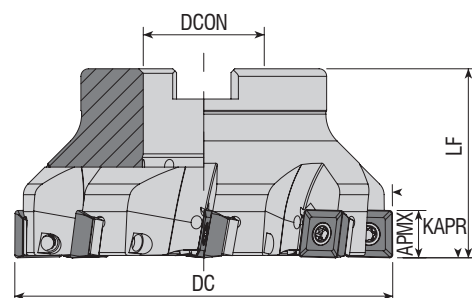

Código del Inserto Le Code de Commande Ordering Code	Stock Stock Stock	Dimension (mm) Dimension (mm) Dimension (mm)					Inserto Plaquette Insert	Recambios / Pièces de Rechange / Spare Parts				
		DC	ZEPF	DCON	LF	APMX		Cuñas Assise Shim	Tornillo de Placa Vis a Assise Shim Screw	Tornillo Vis Screw	Llave Torx Clé Torx Torx Wrench	Tornillo de Fijación Vis de Fixation Mounting Screw
AFM90S-SD1204-D050-A22-Z04-H	●	50	4	22	40	11	SDMT 1204..	AASD-3-0001	AAV-08-M3.5x8	4015-M3.5x12	80-T15	2408-M10x30
AFM90S-SD1204-D063-A22-Z05-H	●	63	5	22	40	11						2508-M10x30
AFM90S-SD1204-D080-A27-Z06-H	●	80	6	27	50	11						2510-M12x35
AFM90S-SD1204-D100-A32-Z08-H	●	100	8	32	50	11						2514-M16x35
AFM90S-SD1204-D125-B40-Z10	●	125	10	40	63	11						-
AFM90S-SD1204-D160-C40-Z12	●	160	12	40	63	11						-

Compatible con el Inserto DJT. / Compatible avec DJT Plaquettes. / Compatible with DJT Insert.

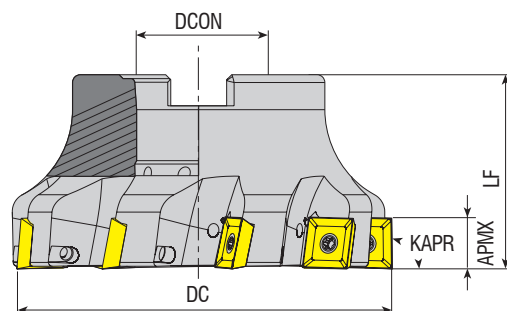

Código del Inserto Le Code de Commande Ordering Code	Stock Stock Stock	Dimension (mm) Dimension (mm) Dimension (mm)					Inserto Plaquette Insert	Recambios / Pièces de Rechange / Spare Parts		
		DC	ZEPF	DCON	LF	APMX		Tornillo Vis Screw	Llave Torx Clé Torx Torx Wrench	Tornillo de Fijación Vis de Fixation Mounting Screw
AFM90-SD09M4-D040-A16-Z04-H	●	40	4	16	40	9	SD.. 09M4..	4015-M3.5x11	80-T15	2406-M8x30
AFM90-SD09M4-D050-A22-Z05-H	●	50	5	22	40	9				2508-M10x30
AFM90-SD09M4-D063-A22-Z06-H	●	63	6	22	40	9				2510-M12x35
AFM90-SD09M4-D080-A27-Z07-H	●	80	7	27	50	9				2408-M10x30
AFM90-SD1305-D050-A22-Z04-H	●	50	4	22	40	13	SD.. 1305..	1020-M5x11	80-T20	2508-M10x30
AFM90-SD1305-D063-A22-Z05-H	●	63	5	22	40	13				2510-M12x35
AFM90-SD1305-D080-A27-Z06-H	●	80	6	27	50	13				2514-M16x35
AFM90-SD1305-D100-A32-Z07-H	●	100	7	32	50	13				-
AFM90-SD1305-D125-B40-Z08	●	125	8	40	63	13				-
AFM90-SD1305-D160-C40-Z10	●	160	10	40	63	13				-

R: Derecha / Droite / Right L: Izquierda / Gauche / Left

● En Existencia / En stock / In Stock ○ Artículo sin Existencia / Indisponible en Stock / Non Stock Item

Compatible con el Inserto KRLY. / Compatible avec KRLY Plaquettes. / Compatible with KRLY Insert.

Ejemplo de Pedido / Exemple de Commande / Ordering Example

1 Piezas / pcs. / pcs. AFM90S-SD1204-D050-A22-Z04-H

Cálculo de Corte : S 369 / Calcul de Coupe : P 369 / Cutting Calculation : 369

Referencia de Montaje : S 366 / Montage Référence : P 366 / Mounting Specifications : 366

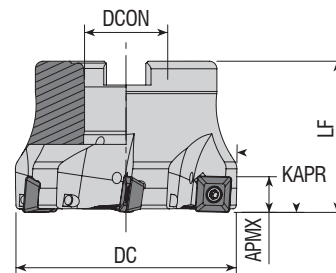

Código del Inserto Le Code de Commande Ordering Code	Stock Stock Stock	Dimension (mm) Dimension (mm) Dimension (mm)					Inserto Plaquette Insert	Recambios / Pièces de Rechange / Spare Parts		
		DC	ZEFP	DCON	LF	APMX		Tornillo Vis Screw	Llave Torx Clé Torx Torx Wrench	Tornillo de fijación Vis de Fixation Mounting Screw
AFM90-SE09-D040-A16-Z04-H	●	40	4	16	40	6.7	SEET 09T3..			2506-M8x30
AFM90-SE09-D050-A22-Z05-H	●	50	5	22	40	6.7				2508-M10x30
AFM90-SE09-D063-A22-Z06-H	●	63	6	22	40	6.7				

Compatible con el Inserto ZCC. / Compatible avec ZCC Plaquettes. / Compatible with ZCC Insert.

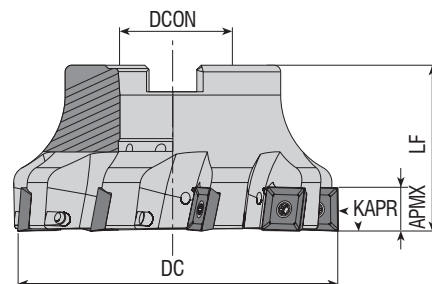

Código del Inserto Le Code de Commande Ordering Code	Stock Stock Stock	Dimension (mm) Dimension (mm) Dimension (mm)					Inserto Plaquette Insert	Recambios / Pièces de Rechange / Spare Parts		
		DC	ZEFP	DCON	LF	APMX		Tornillo Vis Screw	Llave Torx Clé Torx Torx Wrench	Tornillo de fijación Vis de Fixation Mounting Screw
AFM90-SE12-D050-A22-Z04-H	●	50	4	22	40	12	SEET 1203..			2508-M10x30
AFM90-SE12-D063-A22-Z05-H	●	63	5	22	40	12				2510-M12x35
AFM90-SE12-D080-A27-Z07-H	●	80	7	27	50	12				2514-M16x35
AFM90-SE12-D100-A32-Z09-H	●	100	9	32	50	12				
AFM90-SE12-D125-B40-Z11	●	125	11	40	63	12				

R: Derecha / Droite / Right L: Izquierda / Gauche / Left

● En Existencia / En stock / In Stock ○ Artículo sin Existencia / Indisponible en Stock / Non Stock Item
Compatible con el Inserto ZCC. / Compatible avec ZCC Plaquettes. / Compatible with ZCC Insert.

Ejemplo de Pedido / Exemple de Commande / Ordering Example

1 Piezas / pcs. / pcs. AFM90-SE09-D040-A16-Z04-H

Cálculo de Corte : S 369 / Calcul de Coupe : P 369 / Cutting Calculation : 369

Referencia de Montaje : S 366 / Montage Référence : P 366 / Mounting Specifications : 366

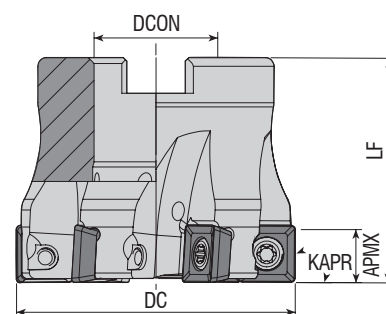

Código del Inserto Le Code de Commande Ordering Code	Stock Stock Stock	Dimension (mm) Dimension (mm) Dimension (mm)					Inserto Plaquette Insert	Recambios / Pièces de Rechange / Spare Parts		
		DC	ZEFP	DCON	LF	APMX		Tornillo Vis Screw	Llave Torx Clé Torx Torx Wrench	Tornillo de Fijación Vis de Fixation Mounting Screw
AFM90-SP1004-D040-A16-Z04-H	●	40	4	16	40	9.4	 SPMT 1004.. XPMT 1004.. QPMR 1004.. QPMT 1004..	 4015-M4x10	 80-T15	2506-M8x30
AFM90-SP1004-D050-A22-Z04-H	●	50	4	22	40	9.4				2508-M10x30
AFM90-SP1004-D050-A22-Z06-H	●	50	6	22	40	9.4				2510-M12x35
AFM90-SP1004-D063-A22-Z05-H	●	63	5	22	40	9.4				2514-M16x35
AFM90-SP1004-D080-A27-Z07-H	●	80	7	27	50	9.4				
AFM90-SP1004-D100-A32-Z08-H	●	100	8	32	50	9.4				

Compatible con el Inserto ISCR. / Compatible avec ISCR Plaquettes. / Compatible with ISCR Insert.

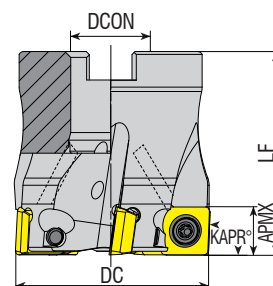

Código del Inserto Le Code de Commande Ordering Code	Stock Stock Stock	Dimension (mm) Dimension (mm) Dimension (mm)					Inserto Plaquette Insert	Recambios / Pièces de Rechange / Spare Parts		
		DC	ZEFP	DCON	LF	APMX		Tornillo Vis Screw	Llave Torx Clé Torx Torx Wrench	Tornillo de Fijación Vis de Fixation Mounting Screw
AFM90-SP09T3-D040-A16-Z05-H	●	40	5	16	40	8.6	 SPMT 09T3..	 3010-M3.5x9	 80-T10	2506-M8x30
AFM90-SP09T3-D050-A22-Z06-H	●	50	6	22	40	8.6				2508-M10x30
AFM90-SP09T3-D063-A22-Z07-H	●	63	7	22	40	8.6				2510-M12x35
AFM90-SP09T3-D080-A27-Z08-H	●	80	8	27	50	8.6				

R: Derecha / Droite / Right L: Izquierda / Gauche / Left

● En Existencia / En stock / In Stock ○ Artículo sin Existencia / Indisponible en Stock / Non Stock Item
Compatible con el Inserto SNDVK. / Compatible avec SNDVK Plaquettes. / Compatible with SNDVK Insert.

Ejemplo de Pedido / Exemple de Commande / Ordering Example

1 Piezas / pcs. / pcs. AFM90-SP1004-D040-A16-Z04-H

Cálculo de Corte : S 369 / Calcul de Coupe : P 369 / Cutting Calculation : 369

Referencia de Montaje : S 366 / Montage Référence : P 366 / Mounting Specifications : 366

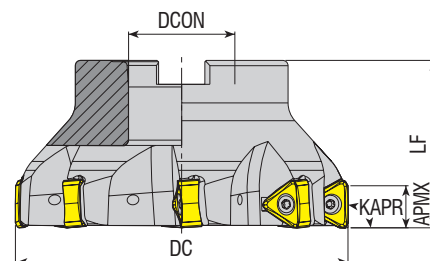

Código del Inserto Le Code de Commande Ordering Code	Stock Stock Stock	Dimension (mm) Dimension (mm) Dimension (mm)					Inserto Plaqueette Insert	Recambios / Pièces de Rechange / Spare Parts				
		DC	ZEFP	DCON	LF	APMX		Tornillo Vis Screw	Llave Torx Clé Torx Torx Wrench	Tornillo de Fijación Vis de Fixation Mounting Screw		
AFM90-TN2207-D063-A22-Z04-H	●	63	4	22	40	15	TN.X 2207..			2508-M10x30		
AFM90-TN2207-D080-A27-Z05-H	●	80	5	27	50	15				1120-M4.5x12	80-T20	2510-M12x35
AFM90-TN2207-D100-B32-Z06	●	100	6	32	50	15						2514-M16x35
AFM90-TN2207-D125-B40-Z08	●	125	8	40	63	15						-

Compatible con el Inserto TGTC. / Compatible avec TGTC Plaquettes. / Compatible with TGTC Insert.

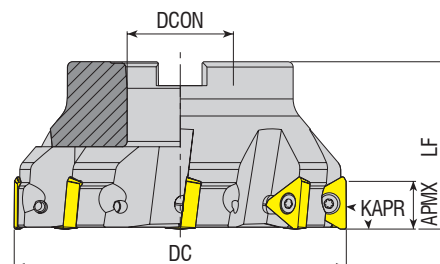

Código del Inserto Le Code de Commande Ordering Code	Stock Stock Stock	Dimension (mm) Dimension (mm) Dimension (mm)					Inserto Plaqueette Insert	Recambios / Pièces de Rechange / Spare Parts				
		DC	ZEFP	DCON	LF	APMX		Tornillo Vis Screw	Llave Torx Clé Torx Torx Wrench	Tornillo de Fijación Vis de Fixation Mounting Screw		
AFM90-TP2205-D063-A22-Z04	●	63	4	22	40	18	TPKT 2205..			2508-M10x30		
AFM90-TP2205-D080-A27-Z06	●	80	6	27	50	18				1120-M4.5x12	80-T20	2510-M12x35
AFM90-TP2205-D100-A32-Z07	●	100	7	32	50	18						2514-M16x35
AFM90-TP2205-D125-B40-Z08	●	125	8	40	63	18						-
AFM90-TP2205-D160-C40-Z09	●	160	9	40	63	18						-
AFM90-TP2205-D200-C60-Z12	●	200	12	60	63	18						-

R: Derecha / Droite / Right L: Izquierda / Gauche / Left

● En Existencia / En stock / In Stock ○ Artículo sin Existencia / Indisponible en Stock / Non Stock Item
Compatible con el Inserto TGTC. / Compatible avec TGTC Plaquettes. / Compatible with TGTC Insert.

Ejemplo de Pedido / Exemple de Commande / Ordering Example

1 Piezas / pcs. / pcs. AFM90-TN2207-D063-A22-Z04-H

Cálculo de Corte : S 369 / Calcul de Coupe : P 369 / Cutting Calculation : 369

Referencia de Montaje : S 366 / Montage Référence : P 366 / Mounting Specifications : 366



KAPR=90°

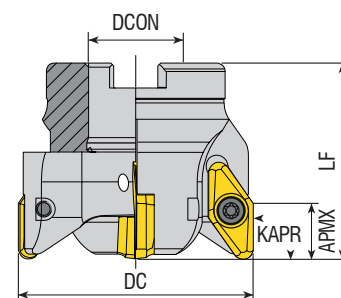

Código del Inserto Le Code de Commande Ordering Code	Stock Stock Stock	Dimension (mm) Dimension (mm) Dimension (mm)					Inserto Plaquette Insert	Recambios / Pièces de Rechange / Spare Parts		
		DC	ZEFP	DCON	LF	APMX		Tornillo Vis Screw	Llave Torx Clé Torx Torx Wrench	Tornillo de Fijación Vis de Fixation Mounting Screw
AFM90-VC2205-D050-A22-Z03-H	●	50	3	22	55	15	VCKT 2205..			2508-M10x30
AFM90-VC2205-D063-A22-Z04-H	●	63	4	22	55	15				
AFM90-VC2205-D066-A27-Z04-H	●	66	4	27	55	15				
AFM90-VC2205-D080-A27-Z05-H	●	80	5	27	60	15				2510-M12x35

Compatible con el Inserto ISO. / Compatible avec ISO Plaquettes. / Compatible with ISO Insert.



KAPR=90°

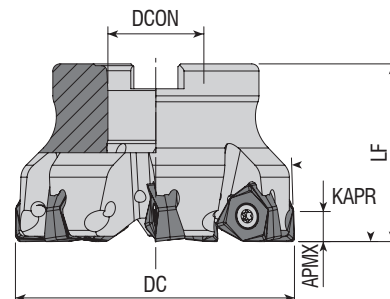

Código del Inserto Le Code de Commande Ordering Code	Stock Stock Stock	Dimension (mm) Dimension (mm) Dimension (mm)					Inserto Plaquette Insert	Recambios / Pièces de Rechange / Spare Parts		
		DC	ZEFP	DCON	LF	APMX		Tornillo Vis Screw	Llave Torx Clé Torx Torx Wrench	Tornillo de Fijación Vis de Fixation Mounting Screw
AFM90-WNG04-D040-A16-Z06-H	●	40	6	16	40	4	WNGU 0403..			2506-M8x30
AFM90-WNG04-D050-A22-Z05-H	●	50	5	22	40	4				
AFM90-WNG04-D050-A22-Z07-H	●	50	7	22	40	4				
AFM90-WNG04-D063-A22-Z06-H	●	63	6	22	40	4	WNGU 0806..			2508-M10x30
AFM90-WNG08-D050-A22-Z05-H	●	50	5	22	40	7.5				
AFM90-WNG08-D063-A22-Z06-H	●	63	6	22	40	7.5				
AFM90-WNG08-D080-A27-Z07-H	●	80	7	27	50	7.5	4015-M4x11	80-T15	2510-M12x35	

R: Derecha / Droite / Right L: Izquierda / Gauche / Left

● En Existencia / En stock / In Stock ○ Artículo sin Existencia / Indisponible en Stock / Non Stock Item

Compatible con el Inserto XTC-GSC. / Compatible avec XTC-GSC Plaquettes. / Compatible with XTC-GSC Insert.

Ejemplo de Pedido / Exemple de Commande / Ordering Example

1 Piezas / pcs. / pcs. AFM90-VC2205-D050-A22-Z03-H

Cálculo de Corte : S 369 / Calcul de Coupe : P 369 / Cutting Calculation : 369

Referencia de Montaje : S 366 / Montage Référence : P 366 / Mounting Specifications : 366

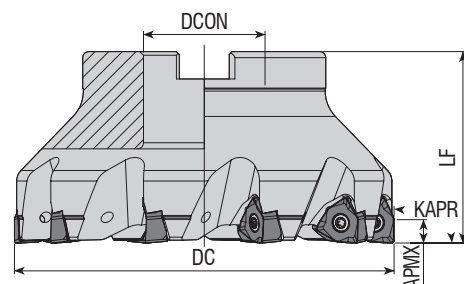

Código del Inserto Le Code de Commande Ordering Code	Stock Stock Stock	Dimension (mm) Dimension (mm) Dimension (mm)					Inserto Plaquette Insert	Recambios / Pièces de Rechange / Spare Parts		
		DC	ZEFP	DCON	LF	APMX		Tornillo Vis Screw	Llave Torx Clé Torx Torx Wrench	Tornillo de Fijación Vis de Fixation Mounting Screw
AFM90-WN0604Z-D040-A16-Z04-H	●	40	4	16	40	5.7	WNHU 0604..	3008-M3x8	80-T08	2506-M8x30
AFM90-WN0604Z-D050-A22-Z05-H	●	50	5	22	40	5.7				2508-M10x30
AFM90-WN0604Z-D063-A22-Z06-H	●	63	6	22	40	5.7				2510-M12x35
AFM90-WN0604Z-D080-A27-Z07-H	●	80	7	27	50	5.7				2514-M16x35
AFM90-WN0604Z-D100-A32-Z09-H	●	100	9	32	50	5.7				-
AFM90-WN0806Z-D050-A22-Z04-H	●	50	4	22	40	7.7	WNHU 0806..	4015-M4x11	80-T15	2508-M10x30
AFM90-WN0806Z-D063-A22-Z05-H	●	63	5	22	40	7.7				2510-M12x35
AFM90-WN0806Z-D080-A27-Z06-H	●	80	6	27	50	7.7				2514-M16x35
AFM90-WN0806Z-D100-A32-Z08-H	●	100	8	32	50	7.7				-
AFM90-WN0806Z-D125-B40-Z10	●	125	10	40	63	7.7				-
AFM90-WN0806Z-D160-C40-Z12	●	160	12	40	63	7.7	-	-	-	

Compatible con el Inserto ZCC. / Compatible avec ZCC Plaquettes. / Compatible with ZCC Insert.

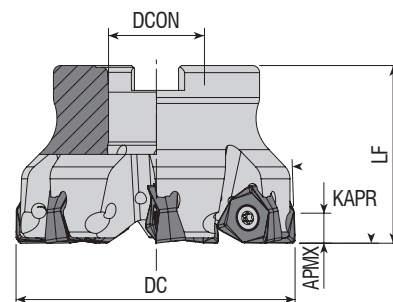

Código del Inserto Le Code de Commande Ordering Code	Stock Stock Stock	Dimension (mm) Dimension (mm) Dimension (mm)					Inserto Plaquette Insert	Recambios / Pièces de Rechange / Spare Parts		
		DC	ZEFP	DCON	LF	APMX		Tornillo Vis Screw	Llave Torx Clé Torx Torx Wrench	Tornillo de Fijación Vis de Fixation Mounting Screw
AFM90-WN0806-D050-A16-Z04-H	●	50	4	16	40	8	WNMX 080608	1615-M5x14	80-T15	2506-M8x30
AFM90-WN0806-D063-A22-Z05-H	●	63	5	22	40	8				2508-M10x30
AFM90-WN0806-D080-A27-Z07-H	●	80	7	27	50	8				2510-M12x35

R: Derecha / Droite / Right L: Izquierda / Gauche / Left

● En Existencia / En stock / In Stock ○ Artículo sin Existencia / Indisponible en Stock / Non Stock Item
Compatible con el Inserto KYCR-JD. / Compatible avec KYCR-JD Plaquettes. / Compatible with KYCR-JD Insert.





Ejemplo de Pedido / Exemple de Commande / Ordering Example

1 Piezas / pcs. / pcs. AFM90-WN0604Z-D040-A16-Z04-H

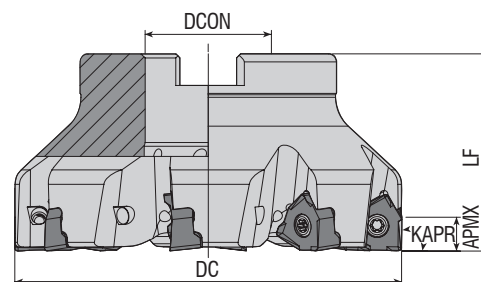
Cálculo de Corte : S 369 / Calcul de Coupe : P 369 / Cutting Calculation : 369

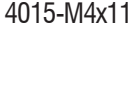

Referencia de Montaje : S 366 / Montage Référence : P 366 / Mounting Specifications : 366

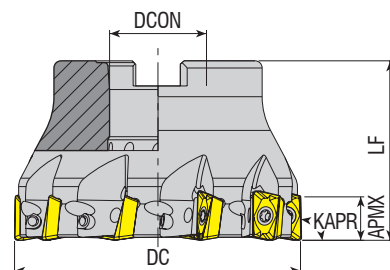

Código del Inserto Le Code de Commande Ordering Code	Stock Stock Stock	Dimension (mm) Dimension (mm) Dimension (mm)					Inserto Plaquette Insert	Recambios / Pièces de Rechange / Spare Parts				
		DC	ZEFP	DCON	LF	APMX		Tornillo Vis Screw	Llave Torx Clé Torx Torx Wrench	Tornillo de Fijación Vis de Fixation Mounting Screw		
AFM90-XN0403-D040-A16-Z05-H	●	40	5	16	40	4	 XNEX 0403..	 3008-M2.5x6	 80-T08	2506-M8x30		
AFM90-XN0806-D050-A22-Z04-H	●	50	4	22	40	7.5				 4015-M4x11	 80-T15	2508-M10x30
AFM90-XN0806-D063-A22-Z05-H	●	63	5	22	40	7.5						2510-M12x35
AFM90-XN0806-D080-A27-Z07-H	●	80	7	27	50	7.5						2514-M16x35
AFM90-XN0806-D100-A32-Z08-H	●	100	8	32	50	7.5						

Compatible con el Inserto SC. / Compatible avec SC Plaquettes. / Compatible with SC Insert.

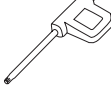

Código del Inserto Le Code de Commande Ordering Code	Stock Stock Stock	Dimension (mm) Dimension (mm) Dimension (mm)					Inserto Plaquette Insert	Recambios / Pièces de Rechange / Spare Parts		
		DC	ZEFP	DCON	LF	APMX		Tornillo Vis Screw	Llave Torx Clé Torx Torx Wrench	Tornillo de Fijación Vis de Fixation Mounting Screw
AFM90-X012-D040-A16-Z05-H	●	40	5	16	40	11	 XO.. 1204..	 3010-M3.5x9	 80-T10	2506-M8x30
AFM90-X012-D050-A22-Z07-H	●	50	7	22	40	11				2508-M10x30
AFM90-X012-D063-A22-Z08-H	●	63	8	22	40	11				2510-M12x35
AFM90-X012-D080-A27-Z10-H	●	80	10	27	50	11				2514-M16x35
AFM90-X012-D100-A32-Z12-H	●	100	12	32	50	11				

R: Derecha / Droite / Right L: Izquierda / Gauche / Left

● En Existencia / En stock / In Stock ○ Artículo sin Existencia / Indisponible en Stock / Non Stock Item
Compatible con el Inserto SC. / Compatible avec SC Plaquettes. / Compatible with SC Insert.

Ejemplo de Pedido / Exemple de Commande / Ordering Example

1 Piezas / pcs. / pcs. AFM90-XN0403-D040-A16-Z05-H

Cálculo de Corte : S 369 / Calcul de Coupe : P 369 / Cutting Calculation : 369

Referencia de Montaje : S 366 / Montage Référence : P 366 / Mounting Specifications : 366

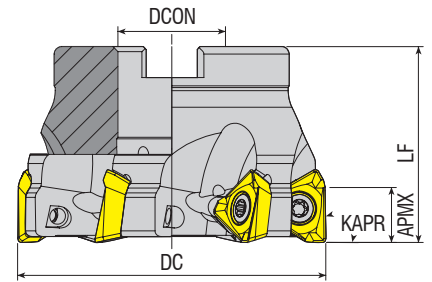

Código del Inserto Le Code de Commande Ordering Code	Stock Stock Stock	Dimension (mm) Dimension (mm) Dimension (mm)					Inserto Plaqueette Insert	Recambios / Pièces de Rechange / Spare Parts		
		DC	ZEFP	DCON	LF	APMX		Tornillo Vis Screw	Llave Torx Clé Torx Torx Wrench	Tornillo de Fijación Vis de Fixation Mounting Screw
AFM90-3P1004-D040-A16-Z05-H	●	40	5	16	40	7	3PKT 1004..	1108-M2.5x6	80-T08	2506-M8x30
AFM90-3P1004-D050-A22-Z06-H	●	50	6	22	40	7				2508-M10x30
AFM90-3P1505-D050-A22-Z04-H	●	50	4	22	40	11	3PKT 1505..	1115-M4x10	80-T15	2510-M12x35
AFM90-3P1505-D050-A22-Z05-H	●	50	5	22	40	11				2514-M16x35
AFM90-3P1505-D063-A22-Z04-H	●	63	4	22	40	11				-
AFM90-3P1505-D063-A22-Z06-H	●	63	6	22	40	11				-
AFM90-3P1505-D080-A27-Z07-H	●	80	7	27	50	11				-
AFM90-3P1505-D100-A32-Z08-H	●	100	8	32	50	11				-
AFM90-3P1505-D125-B40-Z10	●	125	10	40	63	11				-

Compatible con el Inserto TGTC. / Compatible avec TGTC Plaquettes. / Compatible with TGTC Insert.

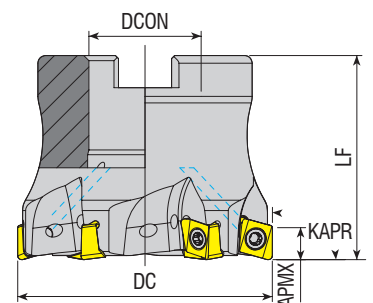

Código del Inserto Le Code de Commande Ordering Code	Stock Stock Stock	Dimension (mm) Dimension (mm) Dimension (mm)					Inserto Plaqueette Insert	Recambios / Pièces de Rechange / Spare Parts		
		DC	ZEFP	DCON	LF	APMX		Tornillo Vis Screw	Llave Torx Clé Torx Torx Wrench	Tornillo de Fijación Vis de Fixation Mounting Screw
AFM90-4N06-D040-A16-Z05-H	●	40	5	16	40	6	4NKT 0603..	1108-M3x6.8	80-T08	2506-M8x30
AFM90-4N06-D050-A22-Z06-H	●	50	6	22	40	6				2508-M10x30

R: Derecha / Droite / Right L: Izquierda / Gauche / Left

● En Existencia / En stock / In Stock ○ Artículo sin Existencia / Indisponible en Stock / Non Stock Item
Compatible con el Inserto TGTC. / Compatible avec TGTC Plaquettes. / Compatible with TGTC Insert.

Ejemplo de Pedido / Exemple de Commande / Ordering Example

1 Piezas / pcs. / pcs. AFM90-3P1004-D040-A16-Z05-H

Cálculo de Corte : S 369 / Calcul de Coupe : P 369 / Cutting Calculation : 369

Referencia de Montaje : S 366 / Montage Référence : P 366 / Mounting Specifications : 366

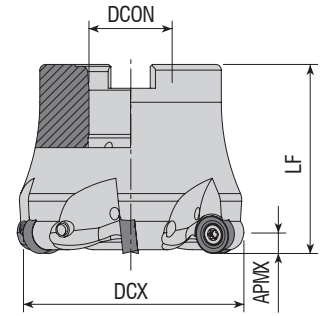

Código del Inserto Le Code de Commande Ordering Code	Stock Stock Stock	Dimension (mm) Dimension (mm) Dimension (mm)					Inserto Plaquette Insert	Recambios / Pièces de Rechange / Spare Parts				
		DCX	ZEFP	DCON	LF	APMX		Tornillo Vis Screw	Llave Torx Clé Torx Torx Wrench	Tornillo de Fijación Vis de Fixation Mounting Screw		
AFMR-RC10T3-D040-A16-Z04-H	●	40	4	16	40	5	RC.. 10T3..			2406-M8x30		
AFMR-RC10T3-D050-A22-Z05-H	●	50	5	22	50	5				4015-M4x11	80-T15	2508-M10x30
AFMR-RC10T3-D063-A22-Z06-H	●	63	6	22	50	5						

Compatible con el Inserto ZCC. / Compatible avec ZCC Plaquettes. / Compatible with ZCC Insert.

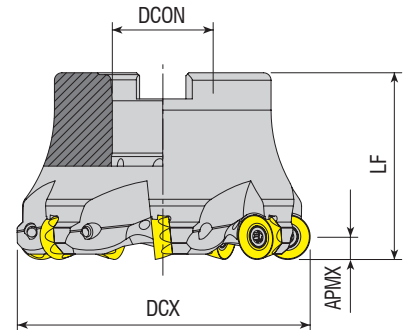

Código del Inserto Le Code de Commande Ordering Code	Stock Stock Stock	Dimension (mm) Dimension (mm) Dimension (mm)					Inserto Plaquette Insert	Recambios / Pièces de Rechange / Spare Parts				
		DCX	ZEFP	DCON	LF	APMX		Tornillo Vis Screw	Llave Torx Clé Torx Torx Wrench	Tornillo de Fijación Vis de Fixation Mounting Screw		
AFMR-RC1204-D040-A16-Z04-H	●	40	4	16	40	6	RC.. 1204..			2506-M8x30		
AFMR-RC1204-D050-A22-Z05-H	●	50	5	22	50	6				4015-M3.5x11	80-T15	2508-M10x30
AFMR-RC1204-D052-A22-Z05-H	●	52	5	22	50	6						2510-M12x35
AFMR-RC1204-D063-A22-Z06-H	●	63	6	22	50	6						
AFMR-RC1204-D063-A27-Z06-H	●	80	6	27	50	6						
AFMR-RC1204-D080-A27-Z07-H	●	80	7	27	50	6						

R: Derecha / Droite / Right L: Izquierda / Gauche / Left

● En Existencia / En stock / In Stock ○ Artículo sin Existencia / Indisponible en Stock / Non Stock Item

Compatible con el Inserto SNDVK. / Compatible avec SNDVK Plaquettes. / Compatible with SNDVK Insert.

Ejemplo de Pedido / Exemple de Commande / Ordering Example

1 Piezas / pcs. / pcs. AFMR-RC10T3-D040-A16-Z04-H

Cálculo de Corte : S 369 / Calcul de Coupe : P 369 / Cutting Calculation : 369

Referencia de Montaje : S 366 / Montage Référence : P 366 / Mounting Specifications : 366

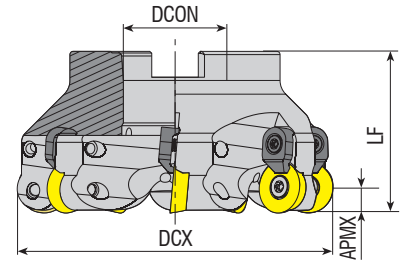

Código del Inserto Le Code de Commande Ordering Code	Stock Stock Stock	Dimension (mm) Dimension (mm) Dimension (mm)					Inserto Plaqueette Insert	Recambios / Pièces de Rechange / Spare Parts					
		DCX	ZEFP	DCON	LF	APMX		Tornillo Vis Screw	Abrazadera de Cuias Mode de Fixation Wedge Clamp	Tornillo de Sujeción Vis de Fixation Wedge Screw	Llave Torx Clé Torx Torx Wrench	Tornillo de Fijación Vis de Fixation Mounting Screw	
AFMR-RD0702-D050-A22-Z06-H	●	50	6	22	40	3.5	RD.. 0702	3008-M2.5x6	-	-	80-T08	2407-M10x30	
AFMR-RD0803-D050-A22-Z05-H	●	50	5	22	40	4	RD.. 0803	3008-M3x8	-	-	80-T08	2407-M10x30	
AFMRC-RD1003-D040-A16-Z04-H	●	40	4	16	40	5	RD.. 1003					2406-M8x30	
AFMRC-RD1003-D050-A22-Z05-H	●	50	5	22	50	5						2508-M10x30	
AFMRC-RD1003-D052-A22-Z05	●	52	5	22	50	5						2510-M12x35	
AFMRC-RD1003-D063-A22-Z06-H	●	63	6	22	50	5						2514-M16x35	
AFMRC-RD1003-D080-A27-Z07-H	●	80	7	27	50	5						2508-M10x30	
AFMRC-RD1003-D100-A32-Z08-H	●	100	8	32	50	5						2406-M8x30	
AFMRC-RD10T3-D050-A22-Z05-H	●	50	5	22	50	5						RD.. 10T3	4015-M3.5x11
AFMRC-RD10T3-D063-A22-Z06-H	●	63	6	22	50	5	2510-M12x35						
AFMRC-RD12T3-D040-A16-Z04-H	●	40	4	16	40	6	RD.. 12T3					2514-M16x35	
AFMRC-RD12T3-D050-A22-Z05-H	●	50	5	22	50	6						-	
AFMRC-RD12T3-D052-A22-Z05-H	●	52	5	22	50	6						2406-M8x30	
AFMRC-RD12T3-D063-A22-Z06-H	●	63	6	22	50	6						2508-M10x30	
AFMRC-RD12T3-D080-A27-Z07-H	●	80	7	27	50	6						2510-M12x35	
AFMRC-RD12T3-D100-A32-Z08-H	●	100	8	32	50	6						2514-M16x35	
AFMRC-RD12T3-D125-B40-Z09	●	125	9	40	63	6						-	
AFMRC-RD1204-D040-A16-Z04-H	●	40	4	16	40	6	RD.. 1204					2406-M8x30	
AFMRC-RD1204-D050-A22-Z05-H	●	50	5	22	50	6						2508-M10x30	
AFMRC-RD1204-D052-A22-Z05-H	●	52	5	22	50	6						2510-M12x35	
AFMRC-RD1204-D063-A22-Z06-H	●	63	6	22	50	6						2514-M16x35	
AFMRC-RD1204-D080-A27-Z07-H	●	80	7	27	50	6						2408-M10x30	
AFMRC-RD1204-D100-A32-Z07-H	●	100	7	32	50	6						2508-M10x30	
AFMRC-RD1204-D100-A32-Z08-H	●	100	8	32	50	6						2510-M12x35	
AFMRC-RD1604-D050-A22-Z04-H	●	50	4	22	50	8	RD.. 1604	4015-M4.5x11	ACK-05	4015-M4x11		2408-M10x30	
AFMRC-RD1604-D052-A22-Z04-H	●	52	4	22	50	8						2508-M10x30	
AFMRC-RD1604-D063-A22-Z05-H	●	63	5	22	50	8						2510-M12x35	
AFMRC-RD1604-D066-A22-Z05-H	●	66	5	22	50	8						2514-M16x35	
AFMRC-RD1604-D066-A27-Z05-H	●	66	5	27	50	8						-	
AFMRC-RD1604-D080-A27-Z06-H	●	80	6	27	50	8						2408-M10x30	
AFMRC-RD1604-D100-A32-Z07-H	●	100	7	32	50	8						2508-M10x30	
AFMRC-RD1604-D100-A32-Z08-H	●	100	8	32	50	8						2510-M12x35	
AFMRC-RD1604-D125-B40-Z07	●	125	7	40	63	8						2514-M16x35	
AFMRC-RD1604-D160-C40-Z08	●	160	8	40	63	8	-						

R: Derecha / Droite / Right L: Izquierda / Gauche / Left

● En Existencia / En stock / In Stock ○ Artículo sin Existencia / Indisponible en Stock / Non Stock Item
 Compatible con el Inserto ISO. / Compatible avec ISO Plaqueettes. / Compatible with ISO Insert.

Ejemplo de Pedido / Exemple de Commande / Ordering Example

1 Piezas / pcs. / pcs. AFMR-RD0702-D050-A22-Z06-H

Cálculo de Corte : S 369 / Calcul de Coupe : P 369 / Cutting Calculation : 369

Referencia de Montaje : S 366 / Montage Référence : P 366 / Mounting Specifications : 366

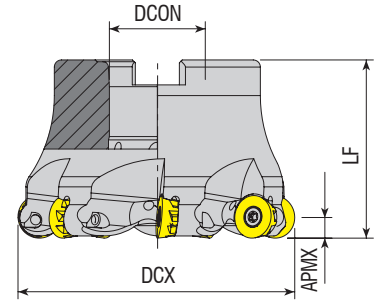

Código del Inserto Le Code de Commande Ordering Code	Stock Stock Stock	Dimension (mm) Dimension (mm) Dimension (mm)					Inserto Plaquette Insert	Recambios / Pièces de Rechange / Spare Parts		
		DCX	ZEFP	DCON	LF	APMX		Tornillo Vis Screw	Llave Torx Clé Torx Torx Wrench	Tornillo de Fijación Vis de Fixation Mounting Screw
AFMR-RP10T3-D063-A22-Z06-H	●	63	6	22	40	5	RPNX 10T3..	4010-M3x8	80-T10	2508-M10x30
AFMR-RP10T3-D080-A27-Z07-H	●	80	7	27	50	5				2510-M12x35
AFMR-RP1204-D040-A16-Z04-H	●	40	4	16	40	6	RPNX 1204..	4015-M3.5x11	80-T15	2406-M8x30
AFMR-RP1204-D080-A27-Z07-H	●	80	7	27	50	6				2510-M12x35

Compatible con el Inserto CRTZT. / Compatible avec CRTZT Plaquettes. / Compatible with CRTZT Insert.

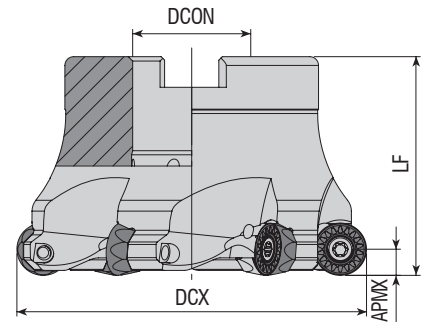

Código del Inserto Le Code de Commande Ordering Code	Stock Stock Stock	Dimension (mm) Dimension (mm) Dimension (mm)					Inserto Plaquette Insert	Recambios / Pièces de Rechange / Spare Parts		
		DCX	ZEFP	DCON	LF	APMX		Tornillo Vis Screw	Llave Torx Clé Torx Torx Wrench	Tornillo de Fijación Vis de Fixation Mounting Screw
AFMR-RP1204M-D050-A22-Z04-H	●	50	4	22	50	6	RPMT 1204..	4015-M4x11	80-T15	2508-M10x30
AFMR-RP1204M-D052-A22-Z05-H	●	52	5	22	50	6				2510-M12x35
AFMR-RP1204M-D063-A22-Z05-H	●	63	5	22	50	6				
AFMR-RP1204M-D080-A27-Z06-H	●	80	6	27	50	6				

R: Derecha / Droite / Right L: Izquierda / Gauche / Left

● En Existencia / En stock / In Stock ○ Artículo sin Existencia / Indisponible en Stock / Non Stock Item

Compatible con el Inserto MTSBH. / Compatible avec MTSBH Plaquettes. / Compatible with MTSBH Insert.

Ejemplo de Pedido / Exemple de Commande / Ordering Example

1 Piezas / pcs. / pcs. AFMR-RP10T3-D063-A22-Z06-H

Cálculo de Corte : S 369 / Calcul de Coupe : P 369 / Cutting Calculation : 369

Referencia de Montaje : S 366 / Montage Référence : P 366 / Mounting Specifications : 366

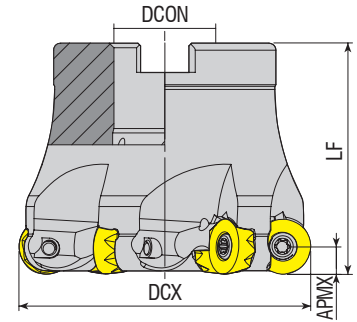

Código del Inserto Le Code de Commande Ordering Code	Stock Stock Stock	Dimension (mm) Dimension (mm) Dimension (mm)					Inserto Plaquette Insert	Recambios / Pièces de Rechange / Spare Parts		
		DCX	ZEFP	DCON	LF	APMX		Tornillo Vis Screw	Llave Torx Clé Torx Torx Wrench	Tornillo de Fijación Vis de Fixation Mounting Screw
AFMR-RY10-D040-A16-Z04-H	●	40	4	16	40	5	RYMX 1004..	4015-M3.5x11	80-T15	2406-M8x30
AFMR-RY10-D040-A16-Z05-H	●	40	5	16	40	5				2506-M8x30
AFMR-RY10-D050-A22-Z05-H	●	50	5	22	50	5				2508-M10x30
AFMR-RY10-D063-A22-Z06-H	●	63	6	22	50	5				2406-M8x30
AFMR-RY12-D040-A16-Z04-H	●	40	4	16	40	6	RYMX 1205..	4015-M4x11	80-T15	2406-M8x30
AFMR-RY12-D050-A22-Z05-H	●	50	5	22	50	6				2508-M10x30
AFMR-RY12-D052-A22-Z05-H	●	52	5	22	50	6				2510-M12x35
AFMR-RY12-D063-A22-Z06-H	●	63	6	22	50	6				2514-M16x35
AFMR-RY12-D080-A27-Z06-H	●	80	6	27	50	6				
AFMR-RY12-D100-A32-Z07-H	●	100	7	32	50	6				

Compatible con el Inserto TGTC. / Compatible avec TGTC Plaquettes. / Compatible with TGTC Insert.

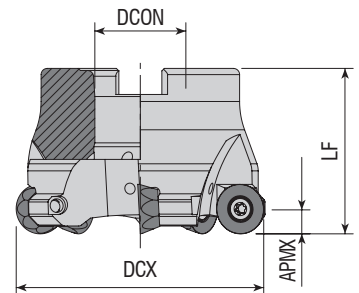

Código del Inserto Le Code de Commande Ordering Code	Stock Stock Stock	Dimension (mm) Dimension (mm) Dimension (mm)					Inserto Plaquette Insert	Recambios / Pièces de Rechange / Spare Parts		
		DCX	ZEFP	DCON	LF	APMX		Tornillo Vis Screw	Llave Torx Clé Torx Torx Wrench	Tornillo de Fijación Vis de Fixation Mounting Screw
AFMR-QP10T3-D040-A16-Z04-H	●	40	4	16	40	5	QP. 10T3..	4015-M3.5x11	80-T15	2506-M8x30
AFMR-QP10T3-D050-A22-Z05-H	●	50	5	22	40	5				2407-M10x30
AFMR-QP10T3-D063-A22-Z06-H	●	63	6	22	40	5				
AFMR-QP1204-D050-A22-Z04-H	●	50	4	22	40	6	QP. 1204..	4015-M4x11	80-T15	
AFMR-QP1204-D063-A22-Z05-H	●	63	5	22	40	6				

R: Derecha / Droite / Right L: Izquierda / Gauche / Left

● En Existencia / En stock / In Stock ○ Artículo sin Existencia / Indisponible en Stock / Non Stock Item
 Compatible con el Inserto SMTM. / Compatible avec SMTM Plaquettes. / Compatible with SMTM Insert.

Ejemplo de Pedido / Exemple de Commande / Ordering Example

1 Piezas / pcs. / pcs. AFMR-RY10-D040-A16-Z04-H

Cálculo de Corte : S 369 / Calcul de Coupe : P 369 / Cutting Calculation : 369

Referencia de Montaje : S 366 / Montage Référence : P 366 / Mounting Specifications : 366

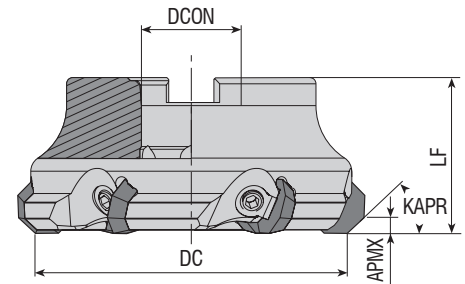

Código del Inserto Le Code de Commande Ordering Code	Stock Stock Stock	Dimension (mm) Dimension (mm) Dimension (mm)					Inserto Plaquette Insert	Recambios / Pièces de Rechange / Spare Parts			
		DC	ZEFP	DCON	LF	APMX		Abrazadera de Cuiñas Mode de Fixation Wedge Clamp	Tornillo de Sujeción Vis de Fixation Wedge Screw	Llaves Allen Clés Allen Allen Wrench	Tornillo de Fijación Vis de Fixation Mounting Screw
AFM43C-OF07-D063-A22-Z04	●	63	4	22	45	5	OF. 0704..	ACK-11	AKV-15-M8x1x20	AAL-05-4	2508-M10x30
AFM43C-OF07-D080-A27-Z05	●	80	5	27	50	5					2510-M12x35
AFM43C-OF07-D100-A32-Z06	●	100	6	32	50	5					2514-M16x35
AFM43C-OF07-D125-B40-Z08	●	125	8	40	63	5					-
AFM43C-OF07-D160-C40-Z09	●	160	9	40	63	5					-

Compatible con el Inserto ISO. / Compatible avec ISO Plaquettes. / Compatible with ISO Insert.

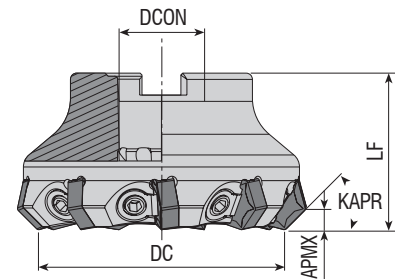

Código del Inserto Le Code de Commande Ordering Code	Stock Stock Stock	Dimension (mm) Dimension (mm) Dimension (mm)					Inserto Plaquette Insert	Recambios / Pièces de Rechange / Spare Parts			
		DC	ZEFP	DCON	LF	APMX		Abrazadera de Cuiñas Mode de Fixation Wedge Clamp	Tornillo de Sujeción Vis de Fixation Wedge Screw	Llaves Allen Clés Allen Allen Wrench	Tornillo de Fijación Vis de Fixation Mounting Screw
AFM45C-HN0905-D063-A22-Z07	●	63	7	22	40	4.5	HN.. 0905..	ACK-11	AKV-15-M8x1x20	AAL-05-4	2508-M10x30
AFM45C-HN0905-D080-A27-Z09	●	80	9	27	50	4.5					2510-M12x35
AFM45C-HN0905-D100-A32-Z11	●	100	11	32	50	4.5					2514-M16x35
AFM45C-HN0905-D125-B40-Z13	●	125	13	40	63	4.5					-
AFM45C-HN0905-D160-C40-Z15	●	160	15	40	63	4.5					-

R: Derecha / Droite / Right L: Izquierda / Gauche / Left

● En Existencia / En stock / In Stock ○ Artículo sin Existencia / Indisponible en Stock / Non Stock Item

Compatible con el Inserto WDA-KNMTL. / Compatible avec WDA-KNMTL Plaquettes. / Compatible with WDA-KNMTL Insert.

Ejemplo de Pedido / Exemple de Commande / Ordering Example

1 Piezas / pcs. / pcs. AFM43C-OF07-D063-A22-Z04

Cálculo de Corte : S 369 / Calcul de Coupe : P 369 / Cutting Calculation : 369

Referencia de Montaje : S 366 / Montage Référence : P 366 / Mounting Specifications : 366

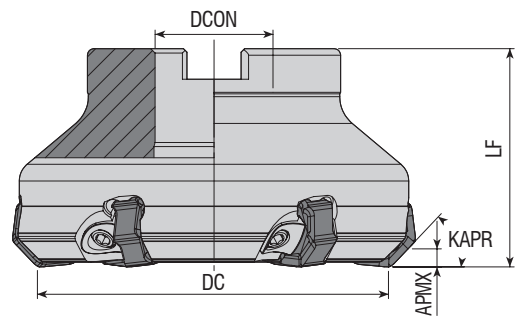

Código del Inserto Le Code de Commande Ordering Code	Stock Stock Stock	Dimension (mm) Dimension (mm) Dimension (mm)					Inserto Plaquette Insert	Recambios / Pièces de Rechange / Spare Parts				
		DC	ZEPF	DCON	LF	APMX		Abrazadera de Cuñas Mode de Fixation Wedge Clamp	Tornillo de Sujeción Vis de Fixation Wedge Screw	Llaves Allen Clés Allen Allen Wrench	Tornillo de Fijación Vis de Fixation Mounting Screw	
AFM45C-XN0806-D063-A22-Z05	●	63	5	22	50	4.5	XNMU 0806..	ACK-26	AKV-26-M6x0.75x20	AAL-03-03	2508-M10x30	
AFM45C-XN0806-D080-A27-Z06	●	80	6	27	50	4.5					2510-M12x35	
AFM45C-XN0806-D100-A32-Z08	●	100	8	32	50	4.5					2514-M16x35	
AFM45C-XN0806-D125-B40-Z08	●	125	8	40	63	4.5					-	
AFM45C-XN0806-D160-C40-Z10	●	160	10	40	63	4.5					-	
AFM45C-XN0806-D200-C60-Z12	●	200	12	60	63	4.5					-	

Compatible con el Inserto DJT. / Compatible avec DJT Plaquettes. / Compatible with DJT Insert.

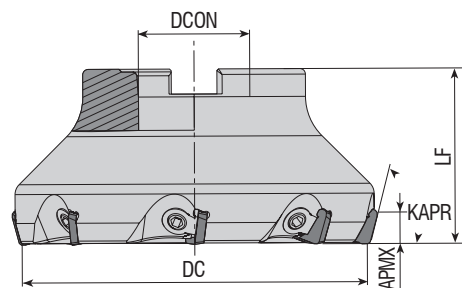

Código del Inserto Le Code de Commande Ordering Code	Stock Stock Stock	Dimension (mm) Dimension (mm) Dimension (mm)					Inserto Plaquette Insert	Recambios / Pièces de Rechange / Spare Parts				
		DC	ZEPF	DCON	LF	APMX		Abrazadera de Cuñas Mode de Fixation Wedge Clamp	Tornillo de Sujeción Vis de Fixation Wedge Screw	Llaves Allen Clés Allen Allen Wrench	Tornillo de Fijación Vis de Fixation Mounting Screw	
AFM75C-SP12-D050-A22-Z04	●	50	4	22	42	8	SPKN 1203..	ACK-10	AKV-22-M8x1x14	AAL-05-4	2508-M10x30	
AFM75C-SP12-D063-A22-Z05	●	63	5	22	40	8					2510-M12x35	
AFM75C-SP12-D080-A27-Z06	●	80	6	27	50	8					2514-M16x35	
AFM75C-SP12-D100-A32-Z07	●	100	7	32	50	8					-	
AFM75C-SP12-D125-B40-Z08	●	125	8	40	63	8					-	
AFM75C-SP12-D160-C40-Z09	●	160	9	40	63	8					-	
AFM75C-SP12-D200-C60-Z12	●	200	12	60	63	8	-					

R: Derecha / Droite / Right L: Izquierda / Gauche / Left
 ● En Existencia / En stock / In Stock ○ Artículo sin Existencia / Indisponible en Stock / Non Stock Item
 Compatible con el Inserto ISO. / Compatible avec ISO Plaquettes. / Compatible with ISO Insert.

Ejemplo de Pedido / Exemple de Commande / Ordering Example
 1 Piezas / pcs. / pcs. AFM45C-XN0806-D063-A22-Z05

Cálculo de Corte : S 369 / Calcul de Coupe : P 369 / Cutting Calculation : 369
 Referencia de Montaje : S 366 / Montage Référence : P 366 / Mounting Specifications : 366

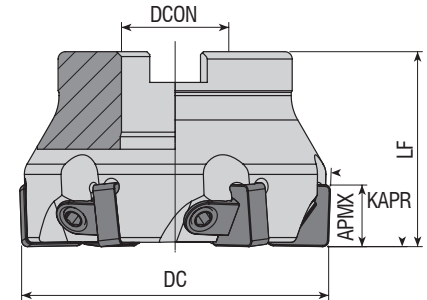

Código del Inserto Le Code de Commande Ordering Code	Stock Stock Stock	Dimension (mm) Dimension (mm) Dimension (mm)					Inserto Plaquette Insert	Recambios / Pièces de Rechange / Spare Parts			
		DC	ZEFP	DCON	LF	APMX		Abrazadera de Cuiñas Mode de Fixation Wedge Clamp	Tornillo de Sujeción Vis de Fixation Wedge Screw	Llaves Allen Clés Allen Allen Wrench	Tornillo de Fijación Vis de Fixation Mounting Screw
AFM88C-SN1204-D050-A22-Z05	●	50	5	22	40	11	SN.. 1204..	ACK-21	AKV-24-M6x1x1	AAL-03-3	2408-M10x30
AFM88C-SN1204-D063-A22-Z06	●	63	6	22	40	11					2510-M12x35
AFM88C-SN1204-D080-A27-Z07	●	80	7	27	50	11					2514-M16x35
AFM88C-SN1204-D100-A32-Z08	●	100	8	32	50	11					-
AFM88C-SN1204-D125-B40-Z11	●	125	11	40	63	11					-

Compatible con el Inserto UNIN-NT.-KYCR. / Compatible avec UNIN-NT.-KYCR Plaquettes. / Compatible with UNIN-NT.-KYCR Insert.

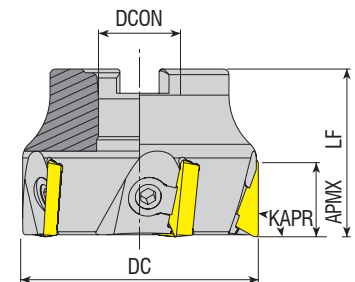

Código del Inserto Le Code de Commande Ordering Code	Stock Stock Stock	Dimension (mm) Dimension (mm) Dimension (mm)					Inserto Plaquette Insert	Recambios / Pièces de Rechange / Spare Parts			
		DC	ZEFP	DCON	LF	APMX		Abrazadera de Cuiñas Mode de Fixation Wedge Clamp	Tornillo de Sujeción Vis de Fixation Wedge Screw	Llaves Allen Clés Allen Allen Wrench	Tornillo de Fijación Vis de Fixation Mounting Screw
AFM90C-TP16-D050-A22-Z04	●	50	4	22	40	12	TP. 1603..	ACK-10	AKV-22-M8x1x14 AKV-13-M8x1x16	AAL-05-4	2407-M10x30
AFM90C-TP16-D063-A22-Z06	●	63	6	22	45	12					2508-M10x30
AFM90C-TP16-D080-A27-Z07	●	80	7	27	50	12					2510-M12x35
AFM90C-TP16-D100-A32-Z08	●	100	8	32	50	12					2514-M16x35
AFM90C-TP16-D125-B40-Z08	●	125	8	40	63	12					-
AFM90C-TP22-D063-A22-Z05	●	63	5	22	45	18	TP. 2204..	ACK-11	AKV-14-M8x1x18	AAL-05-4	2508-M10x30
AFM90C-TP22-D080-A27-Z06	●	80	6	27	50	18					2510-M12x35
AFM90C-TP22-D100-A32-Z07	●	100	7	32	50	18					2514-M16x35
AFM90C-TP22-D125-B40-Z08	●	125	8	40	63	18					-
AFM90C-TP22-D160-C40-Z09	●	160	9	40	63	18					-
AFM90C-TP22-D200-C60-Z12	●	200	12	60	63	18					-
AFM90C-TP22-D250-C60-Z15	●	250	15	60	63	18					-
AFM90C-TP22-D315-D60-Z18	●	315	18	60	63	18	-				

R: Derecha / Droite / Right L: Izquierda / Gauche / Left

● En Existencia / En stock / In Stock ○ Artículo sin Existencia / Indisponible en Stock / Non Stock Item

Compatible con el Inserto ISO. / Compatible avec ISO Plaquettes. / Compatible with ISO Insert.

Ejemplo de Pedido / Exemple de Commande / Ordering Example

1 Piezas / pcs. / pcs. AFM88C-SN1204-D050-A22-Z05

Cálculo de Corte : S 369 / Calcul de Coupe : P 369 / Cutting Calculation : 369

Referencia de Montaje : S 366 / Montage Référence : P 366 / Mounting Specifications : 366

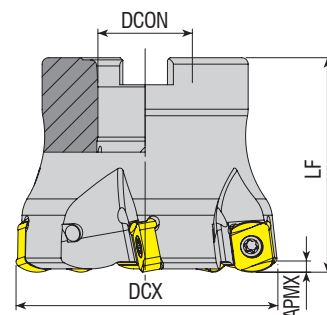

Código del Inserto Le Code de Commande Ordering Code	Stock Stock Stock	Dimension (mm) Dimension (mm) Dimension (mm)					Inserto Plaqueette Insert	Recambios / Pièces de Rechange / Spare Parts		
		DCX	ZEFP	DCON	LF	APMX		Tornillo Vis Screw	Llave Torx Clé Torx Torx Wrench	Tornillo de Fijación Vis de Fixation Mounting Screw
AHFM-BL0603-D040-A16-Z06-H	●	40	6	16	40	1	BLMP 0603..	3008-M2.5x6	80-T08	2506-M8x30
AHFM-BL0603-D050-A22-Z07-H	●	50	7	22	40	1				
AHFM-BL0904-D040-A16-Z05-H	●	40	5	16	40	2	BLMP 0904..	3010-M3.5x9	80-T10	2508-M10x30
AHFM-BL0904-D050-A22-Z06-H	●	50	6	22	50	2				
AHFM-BL0904-D063-A22-Z05-H	●	63	5	22	50	2				
AHFM-BL0904-D063-A22-Z07-H	●	63	7	22	50	2				

Compatible con el Inserto TGTC. / Compatible avec TGTC Plaquettes. / Compatible with TGTC Insert.

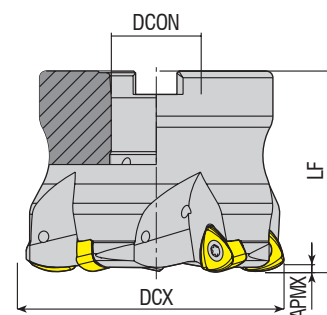

Código del Inserto Le Code de Commande Ordering Code	Stock Stock Stock	Dimension (mm) Dimension (mm) Dimension (mm)					Inserto Plaqueette Insert	Recambios / Pièces de Rechange / Spare Parts		
		DCX	ZEFP	DCON	LF	APMX		Tornillo Vis Screw	Llave Torx Clé Torx Torx Wrench	Tornillo de Fijación Vis de Fixation Mounting Screw
AHFM-BL1205-D050-A22-Z03-H	●	50	3	22	40	2	BLMP 1205..	4015-M4x11	80-T15	2508-M10x30
AHFM-BL1205-D063-A22-Z04-H	●	63	4	22	40	2				2510-M12x35
AHFM-BL1205-D080-A27-Z05-H	●	80	5	27	50	2				

R: Derecha / Droite / Right L: Izquierda / Gauche / Left

● En Existencia / En stock / In Stock ○ Artículo sin Existencia / Indisponible en Stock / Non Stock Item
 Compatible con el Inserto TGTC. / Compatible avec TGTC Plaquettes. / Compatible with TGTC Insert.

Ejemplo de Pedido / Exemple de Commande / Ordering Example

1 Piezas / pcs. / pcs. AHFM-BL0603-D040-A16-Z06-H

Cálculo de Corte : S 369 / Calcul de Coupe : P 369 / Cutting Calculation : 369

Referencia de Montaje : S 366 / Montage Référence : P 366 / Mounting Specifications : 366

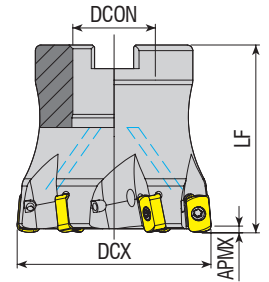

Código del Inserto Le Code de Commande Ordering Code	Stock Stock	Dimension (mm) Dimension (mm)					Inserto Plaquelette Insert	Recambios / Pièces de Rechange / Spare Parts		
		DCX	ZEFP	DCON	LF	APMX		Tornillo Vis Screw	Llave Torx Clé Torx Torx Wrench	Tornillo de Fijación Vis de Fixation Mounting Screw
AHFM-EN1004-D050-A22-Z05-H	●	50	5	22	50	1				
AHFM-EN1004-D050-A22-Z06-H	●	50	6	22	50	1				
AHFM-EN1004-D052-A22-Z06-H	●	52	6	22	50	1				
AHFM-EN1004-D063-A22-Z06-H	●	63	6	22	50	1				

Compatible con el Inserto DJT. / Compatible avec DJT Plaquettes. / Compatible with DJT Insert.

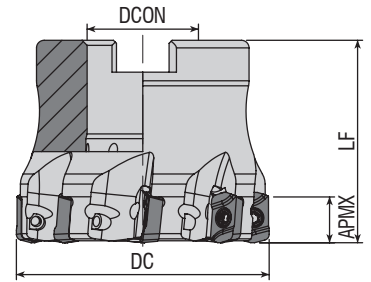

Código del Inserto Le Code de Commande Ordering Code	Stock Stock	Dimension (mm) Dimension (mm)					Inserto Plaquelette Insert	Recambios / Pièces de Rechange / Spare Parts		
		DC	ZEFP	DCON	LF	APMX		Tornillo Vis Screw	Llave Torx Clé Torx Torx Wrench	Tornillo de Fijación Vis de Fixation Mounting Screw
AHFM-EP1003-D050-A22-Z08-H	●	50	8	22	40	1				
AHFM-EP1003-D063-A22-Z08-H	●	63	8	22	40	1				

R: Derecha / Droite / Right L: Izquierda / Gauche / Left

● En Existencia / En stock / In Stock ○ Artículo sin Existencia / Indisponible en Stock / Non Stock Item

Compatible con el Inserto DJT. / Compatible avec DJT Plaquettes. / Compatible with DJT Insert.

Ejemplo de Pedido / Exemple de Commande / Ordering Example

1 Piezas / pcs. / pcs. AHFM-EN1004-D050-A22-Z05-H

Cálculo de Corte : S 369 / Calcul de Coupe : P 369 / Cutting Calculation : 369

Referencia de Montaje : S 366 / Montage Référence : P 366 / Mounting Specifications : 366

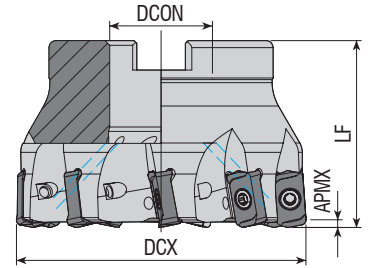

Código del Inserto Le Code de Commande Ordering Code	Stock Stock Stock	Dimension (mm) Dimension (mm) Dimension (mm)					Inserto Plaquette Insert	Recambios / Pièces de Rechange / Spare Parts					
		DCX	ZEFP	DCON	LF	APMX		Tornillo Vis Screw	Llave Torx Clé Torx Torx Wrench	Tornillo de Fijación Vis de Fixation Mounting Screw			
AHFM-L003-D040-A16-Z06-H	●	40	6	16	40	1	LOGU 0303..						
AHFM-L003-D050-A22-Z07-H	●	50	7	22	40	1					1108-M3x6.8	80-T08	2506-M8x30
AHFM-L003-D063-A22-Z09-H	●	63	9	22	40	1							2508-M10x30

Compatible con el Inserto KYCR. / Compatible avec KYCR Plaquettes. / Compatible with KYCR Insert.

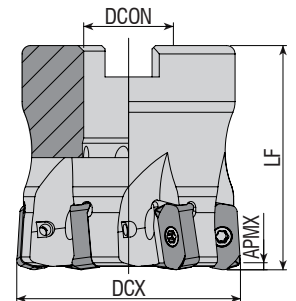

Código del Inserto Le Code de Commande Ordering Code	Stock Stock Stock	Dimension (mm) Dimension (mm) Dimension (mm)					Inserto Plaquette Insert	Recambios / Pièces de Rechange / Spare Parts					
		DCX	ZEFP	DCON	LF	APMX		Tornillo Vis Screw	Llave Torx Clé Torx Torx Wrench	Tornillo de Fijación Vis de Fixation Mounting Screw			
AHFM-LN0303-D040-A16-Z06-H	●	40	6	16	40	12	LNMU 0303..						
AHFM-LN0303-D050-A22-Z07-H	●	50	7	22	50	12					3008-M2.5X6	80-T08	2506-M8x30
AHFM-LN0303-D063-A22-Z09-H	●	63	9	22	50	12							2508-M10x30

R: Derecha / Droite / Right L: Izquierda / Gauche / Left

● En Existencia / En stock / In Stock ○ Artículo sin Existencia / Indisponible en Stock / Non Stock Item
 Compatible con el Inserto TNGLY. / Compatible avec TNGLY Plaquettes. / Compatible with TNGLY Insert.

Ejemplo de Pedido / Exemple de Commande / Ordering Example

1 Piezas / pcs. / pcs. AHFM-L003-D040-A16-Z06-H

Cálculo de Corte : S 369 / Calcul de Coupe : P 369 / Cutting Calculation : 369

Referencia de Montaje : S 366 / Montage Référence : P 366 / Mounting Specifications : 366

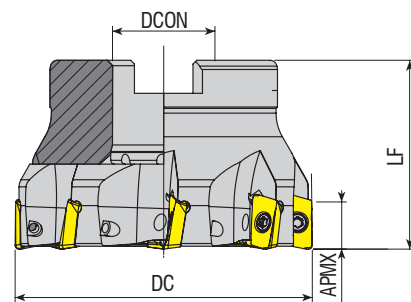

Código del Inserto Le Code de Commande Ordering Code	Stock Stock Stock	Dimension (mm) Dimension (mm) Dimension (mm)					Inserto Plaquette Insert	Recambios / Pièces de Rechange / Spare Parts			
		DC	ZFP	DCON	LF	APMX		Tornillo Vis Screw	Llave Torx Clé Torx Torx Wrench	Tornillo de Fijación Vis de Fixation Mounting Screw	
AHFM-JD1003-D040-A16-Z06-H	●	40	6	16	40	9	JDMT 1003..	3008-M2.5x6	80-T08	2506-M8x30	
AHFM-JD1003-D063-A22-Z08-H	●	63	8	22	40	9				2508-M10x30	

Compatible con el Inserto MTSBH. / Compatible avec MTSBH Plaquettes. / Compatible with MTSBH Insert.

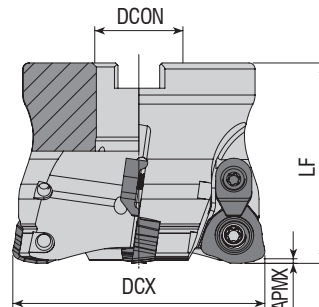

Código del Inserto Le Code de Commande Ordering Code	Stock Stock Stock	Dimension (mm) Dimension (mm) Dimension (mm)					Inserto Plaquette Insert	Recambios / Pièces de Rechange / Spare Parts				
		DCX	ZFP	DCON	LF	APMX		Tornillo Vis Screw	Abrazadera de Cuñas Mode de Fixation Wedge Clamp	Tornillo de Sujeción Vis de Fixation Wedge Screw	Llave Torx Clé Torx Torx Wrench	Tornillo de Fijación Vis de Fixation Mounting Screw
AHFMC-JD1204-D052-A22-Z03-H	●	52	3	22	50	1.5	JDMW 1204..	4615-M4x11	ACK-05	4015-M4x11	80-T15	2508-M10x30
AHFMC-JD1204-D052-A22-Z04-H	●	52	4	22	50	1.5						2510-M12x35
AHFMC-JD1204-D063-A22-Z05-H	●	63	5	22	50	1.5						2514-M16x35
AHFMC-JD1204-D080-A27-Z06-H	●	80	6	27	50	1.5						2408-M10x30
AHFMC-JD1204-D100-A32-Z07-H	●	100	7	32	50	1.5						2508-M10x30
AHFMC-JD1405-D052-A22-Z03-H	●	52	3	22	40	2	JDMW 1405..	1020-M5x11			80-T20	2408-M10x30
AHFMC-JD1405-D063-A22-Z04-H	●	63	4	22	40	2						2508-M10x30

R: Derecha / Droite / Right L: Izquierda / Gauche / Left

● En Existencia / En stock / In Stock ○ Artículo sin Existencia / Indisponible en Stock / Non Stock Item
 Compatible con el Inserto MTSBH. / Compatible avec MTSBH Plaquettes. / Compatible with MTSBH Insert.

Ejemplo de Pedido / Exemple de Commande / Ordering Example

1 Piezas / pcs. / pcs. AHFM-JD1003-D040-A16-Z06-H

Cálculo de Corte : S 369 / Calcul de Coupe : P 369 / Cutting Calculation : 369

Referencia de Montaje : S 366 / Montage Référence : P 366 / Mounting Specifications : 366

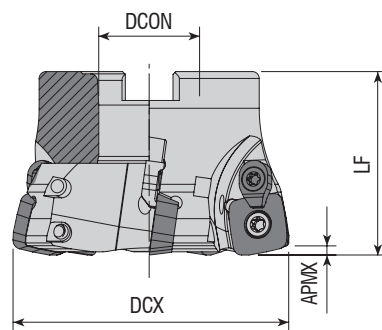

Código del Inserto Le Code de Commande Ordering Code	Stock Stock Stock	Dimension (mm) Dimension (mm) Dimension (mm)					Inserto Plaquette Insert	Recambios / Pièces de Rechange / Spare Parts				
		DCX	ZEFP	DCON	Lf	APMX		Tornillo Vis Screw	Abrazadera de Cuñas Mode de Fixation Wedge Clamp	Tornillo de Sujeción Vis de Fixation Wedge Screw	Llave Torx Clé Torx Torx Wrench	Tornillo de Fijación Vis de Fixation Mounting Screw
AHFMC-SD1204-D050-A22-Z04-H	●	50	4	22	40	1.8	SD.. 1204..					
AHFMC-SD1204-D063-A22-Z05-H	●	63	5	22	40	1.8						
AHFMC-SD1204-D080-A27-Z06-H	●	80	6	27	50	1.8						
AHFMC-SD1204-D100-A32-Z08-H	●	100	8	32	50	1.8						

Compatible con el Inserto ZGC. / Compatible avec ZGC Plaquettes. / Compatible with ZCC Insert.

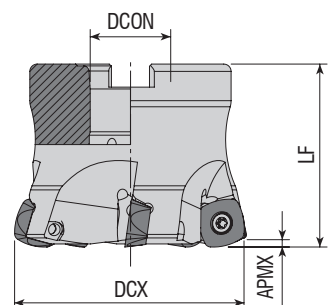

Código del Inserto Le Code de Commande Ordering Code	Stock Stock Stock	Dimension (mm) Dimension (mm) Dimension (mm)					Inserto Plaquette Insert	Recambios / Pièces de Rechange / Spare Parts		
		DCX	ZEFP	DCON	Lf	APMX		Tornillo Vis Screw	Llave Torx Clé Torx Torx Wrench	Tornillo de Fijación Vis de Fixation Mounting Screw
AHFM-SD1205-D052-A22-Z04-H	●	52	4	22	50	2	SD.. 1205..			
AHFM-SD1205-D052-A22-Z05-H	●	52	5	22	50	2				
AHFM-SD1205-D066-A22-Z05-H	●	66	5	22	50	2				
AHFM-SD1205-D066-A22-Z06-H	●	66	6	22	50	2				
AHFM-SD1205-D080-A27-Z06-H	●	80	6	27	70	2				

R: Derecha / Droite / Right L: Izquierda / Gauche / Left

● En Existencia / En stock / In Stock ○ Artículo sin Existencia / Indisponible en Stock / Non Stock Item
 Compatible con el Inserto HTCH. / Compatible avec HTCH Plaquettes. / Compatible with HTCH Insert.





Ejemplo de Pedido / Exemple de Commande / Ordering Example

1 Piezas / pcs. / pcs. AHFM-SD1204-D050-A22-Z04-H

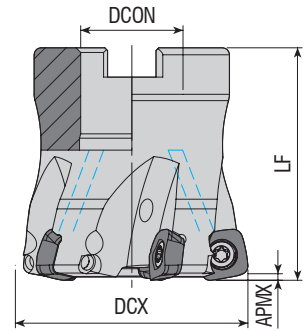
Cálculo de Corte : S 369 / Calcul de Coupe : P 369 / Cutting Calculation : 369





Referencia de Montaje : S 366 / Montage Référence : P 366 / Mounting Specifications : 366

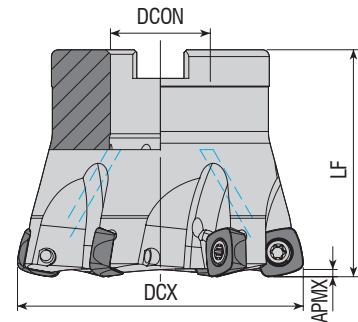

Código del Inserto Le Code de Commande Ordering Code	Stock Stock Stock	Dimension (mm) Dimension (mm) Dimension (mm)					Inserto Plaquette Insert	Recambios / Pièces de Rechange / Spare Parts					
		DCX	ZEFP	DCON	LF	APMX		Tornillo Vis Screw	Llave Torx Clé Torx Torx Wrench	Tornillo de Fijación Vis de Fixation Mounting Screw			
AHFM-SO1004-D050-A22-Z05-H	●	50	5	22	50	1.5							
AHFM-SO1004-D063-A22-Z06-H	●	63	6	22	50	SOMT 1004..					4015-M4x11	80-T15	2508-M10x30
AHFM-SO1004-D080-A27-Z07-H	●	80	7	27	63	1.5							2510-M12x35

Compatible con el Inserto KYCR. / Compatible avec KYCR Plaquettes. / Compatible with KYCR Insert.

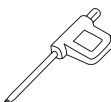

Código del Inserto Le Code de Commande Ordering Code	Stock Stock Stock	Dimension (mm) Dimension (mm) Dimension (mm)					Inserto Plaquette Insert	Recambios / Pièces de Rechange / Spare Parts						
		DCX	ZEFP	DCON	LF	APMX		Tornillo Vis Screw	Llave Torx Clé Torx Torx Wrench	Tornillo de Fijación Vis de Fixation Mounting Screw				
AHFM-SP1004-D050-A22-Z05-H	●	50	5	22	50	1.5								
AHFM-SP1004-D052-A22-Z05-H	●	52	5	22	50	1.5					SPNW 1004..	3015-M3.5x9	80-T15	2508-M10x30
AHFM-SP1004-D063-A22-Z06-H	●	63	6	22	50	1.5								

R: Derecha / Droite / Right L: Izquierda / Gauche / Left

● En Existencia / En stock / In Stock ○ Artículo sin Existencia / Indisponible en Stock / Non Stock Item
Compatible con el Inserto DJT. / Compatible avec DJT Plaquettes. / Compatible with DJT Insert.

Ejemplo de Pedido / Exemple de Commande / Ordering Example

1 Piezas / pcs. / pcs. AHFM-SO1004-D050-A22-Z05-H

Cálculo de Corte : S 369 / Calcul de Coupe : P 369 / Cutting Calculation : 369

Referencia de Montaje : S 366 / Montage Référence : P 366 / Mounting Specifications : 366

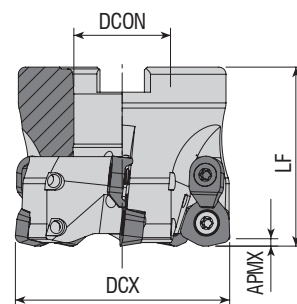

Código del Inserto Le Code de Commande Ordering Code	Stock Stock Stock	Dimension (mm) Dimension (mm) Dimension (mm)					Inserto Plaquette Insert	Recambios / Pièces de Rechange / Spare Parts					
		DCX	ZEPF	DCON	LF	APMX		Tornillo Vis Screw	Abrazadera de Cuñas Mode de Fixation Wedge Clamp	Tornillo de Sujeción Vis de Fixation Wedge Screw	Llave Torx Clé Torx Torx Wrench	Tornillo de Fijación Vis de Fixation Mounting Screw	
AHFMC-WD06T3D-D042-A16-Z04-H	●	42	4	16	45	1.5	WD.W 06T3..		3015-M3.5x9	ACK-15	4015-M3.5x11	80-T15	
AHFMC-WD06T3D-D050-A22-Z05-H	●	50	5	22	50	1.5							
AHFMC-WD06T3D-D052-A22-Z05-H	●	52	5	22	50	1.5							
AHFMC-WD0805D-D052-A22-Z04-H	●	52	4	22	50	2	WD.W 0805..		4020-M4.5x12	ACK-19	4020-M4.5x12	80-T20	
AHFMC-WD0805D-D063-A22-Z05-H	●	63	5	22	50	2							
AHFMC-WD0805D-D063-A27-Z05-H	●	63	5	27	50	2							
AHFMC-WD0805D-D066-A27-Z05-H	●	66	5	27	50	2							
AHFMC-WD0805D-D080-A27-Z05	●	80	5	27	50	2							
AHFMC-WD0805D-D100-A32-Z06	●	100	6	32	50	2							
AHFMC-WD10X6D-D125-B40-Z06	●	125	6	40	63	2.5	WD.W 10X6..		-	-	-	-	
AHFMC-WD10X6D-D160-C40-Z07	●	160	7	40	63	2.5							

Compatible con el Inserto DJT. / Compatible avec DJT Plaquettes. / Compatible with DJT Insert.

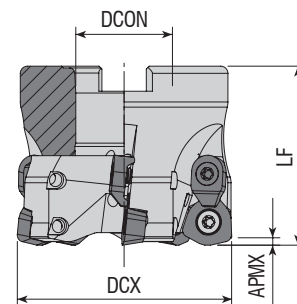

Código del Inserto Le Code de Commande Ordering Code	Stock Stock Stock	Dimension (mm) Dimension (mm) Dimension (mm)					Inserto Plaquette Insert	Recambios / Pièces de Rechange / Spare Parts					
		DCX	ZEPF	DCON	LF	APMX		Tornillo Vis Screw	Abrazadera de Cuñas Mode de Fixation Wedge Clamp	Tornillo de Sujeción Vis de Fixation Wedge Screw	Llave Torx Clé Torx Torx Wrench	Tornillo de Fijación Vis de Fixation Mounting Screw	
AHFMC-WD0804-D040-A16-Z04-H	●	40	4	16	40	1.5	WDMT 0804..		4010-M3x8	ACK-15	4010-M3x8	80-T10	
AHFMC-WD0804-D050-A22-Z04-H	●	50	4	22	50	1.5							
AHFMC-WD1205-D050-A22-Z04-H	●	50	4	22	50	3	WDMT 1205..		1415-M4x11	ACK-05	4015-M4x11	80-T15	
AHFMC-WD1205-D052-A22-Z04-H	●	52	4	22	50	3							
AHFMC-WD1205-D063-A22-Z05-H	●	63	5	22	50	3							
AHFMC-WD1205-D080-A27-Z06-H	●	80	6	27	63	3							

R: Derecha / Droite / Right L: Izquierda / Gauche / Left

● En Existencia / En stock / In Stock ○ Artículo sin Existencia / Indisponible en Stock / Non Stock Item
 Compatible con el Inserto SMTM. / Compatible avec SMTM Plaquettes. / Compatible with SMTM Insert.

Ejemplo de Pedido / Exemple de Commande / Ordering Example

1 Piezas / pcs. / pcs. AHFMC-WD06T3D-D042-A16-Z04-H

Cálculo de Corte : S 369 / Calcul de Coupe : P 369 / Cutting Calculation : 369

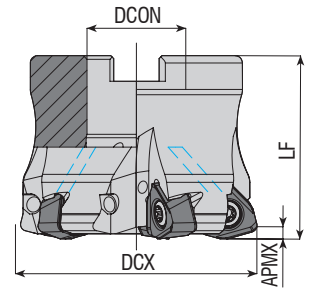

Código del Inserto Le Code de Commande Ordering Code	Stock Stock	Dimension (mm) Dimension (mm) Dimension (mm)					Inserto Plaquette Insert	Recambios / Pièces de Rechange / Spare Parts		
		DCX	ZEFP	DCON	LF	APMX		Tornillo Vis Screw	Llave Torx Clé Torx Torx Wrench	Tornillo de Fijación Vis de Fixation Mounting Screw
AHFM-WN0907-D050-A22-Z04-H	●	50	4	22	50	3	WNMU 0907..	1020-M5x14	80-T20	2508-M10x30
AHFM-WN0907-D052-A22-Z04-H	●	52	4	22	50	3				
AHFM-WN0907-D063-A22-Z05-H	●	63	5	22	50	3				
AHFM-WN0907-D066-A27-Z05-H	●	66	5	27	50	3				2510-M12x35
AHFM-WN0907-D080-A27-Z06-H	●	80	6	27	50	3				
AHFM-WN0907-D100-A32-Z07-H	●	100	7	32	50	3				

Compatible con el Inserto DJT. / Compatible avec DJT Plaquettes. / Compatible with DJT Insert.

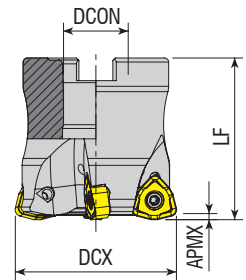

Código del Inserto Le Code de Commande Ordering Code	Stock Stock	Dimension (mm) Dimension (mm) Dimension (mm)					Inserto Plaquette Insert	Recambios / Pièces de Rechange / Spare Parts		
		DCX	ZEFP	DCON	LF	APMX		Tornillo Vis Screw	Llave Torx Clé Torx Torx Wrench	Tornillo de Fijación Vis de Fixation Mounting Screw
AHFM-WN09T3-D040-A16-Z04-H	●	40	4	16	40	1.5	WNMX 09T3..	4010-M3x8	80-T10	2506-M8x30
AHFML-WN09T3-D040-A16-Z04-H	●	40	4	16	40	1.5				
AHFM-WN09T3-D050-A22-Z05-H	●	50	5	22	40	1.5				2508-M10x30
AHFML-WN09T3-D050-A22-Z05-H	●	50	5	22	40	1.5				
AHFM-WN09T3-D063-A22-Z06-H	●	63	6	22	40	1.5				

R: Derecha / Droite / Right L: Izquierda / Gauche / Left

● En Existencia / En stock / In Stock ○ Artículo sin Existencia / Indisponible en Stock / Non Stock Item
 Compatible con el Inserto KRLY. / Compatible avec KRLY Plaquettes. / Compatible with KRLY Insert.

Ejemplo de Pedido / Exemple de Commande / Ordering Example

1 Piezas / pcs. / pcs. AHFM-WN0907-D050-A22-Z04-H

Cálculo de Corte : S 369 / Calcul de Coupe : P 369 / Cutting Calculation : 369

Referencia de Montaje : S 366 / Montage Référence : P 366 / Mounting Specifications : 366

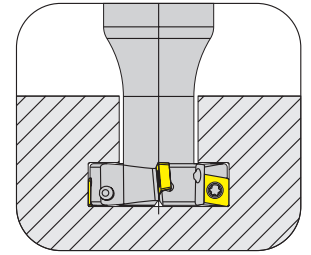
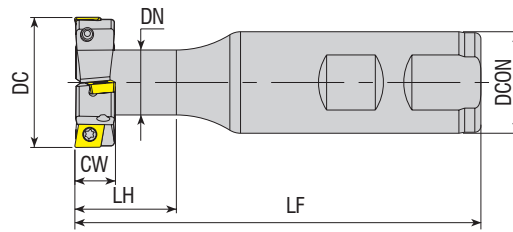

Código del Inserto
Le Code de Commande
Ordering Code

Stock Stock Stock	Dimension (mm) Dimension (mm) Dimension (mm)								Inserto Plaquette Insert	Recambios / Pièces de Rechange / Spare Parts		
	ZEPF		DC	CW	DCON	LF	DN	LH		Tornillo Vis Screw	Llave Torx Clé Torx Torx Wrench	
	Total Total Total	Eficaz Efficace Effective										
●	2	1	17	8	16	85	10	16	CC.T 0602..	3008-M2.5x6	80-T08	
●	4	2	32	8	25	100	16	23				
●	4	2	28	8	20	66	14	15.5				
●	6	3	45.5	8	25	100	12	30				
●	8	4	63	8	32	125	31.5	30				
●	2	1	18	9	16	90	10	16				
●	4	2	20	9	16	85	10	16				
●	4	2	23	10	20	90	12	25				
●	4	2	32	10	25	100	16	25				
●	6	3	45	10	32	120	20	25				
●	4	2	25	11	25	100	13	20	CC.T 09T3..	4015-M3.5x9	80-T15	
●	4	2	30	12	25	100	16	25				
●	2	1	32	12	25	100	16	25				
●	4	2	32	12	25	100	16	25				
●	4	2	32	14	25	100	16	25				
●	4	2	37	16	32	120	17	30				
●	4	2	40	17	32	120	19	30				
●	4	2	42	17	32	120	19	30				
●	4	2	47	20	32	120	25	45				
●	4	2	52	21	32	120	25	45				
●	4	2	50	22	32	120	25	45	CC.T 1204..	1020-M5x11	80-T20	
●	4	2	55	22	32	120	25	45				

R: Derecha / Droite / Right L: Izquierda / Gauche / Left

● En Existencia / En stock / In Stock ○ Artículo sin Existencia / Indisponible en Stock / Non Stock Item
Compatible con el Inserto ISO. / Compatible avec ISO Plaquettes. / Compatible with ISO Insert.

Ejemplo de Pedido / Exemple de Commande / Ordering Example

1 Piezas / pcs. / pcs. ATSM90-CC06-D17X8-W16-L85-Z02
Cálculo de Corte : S 369 / Calcul de Coupe : P 369 / Cutting Calculation : 369



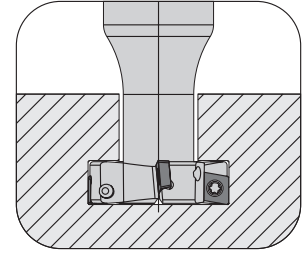
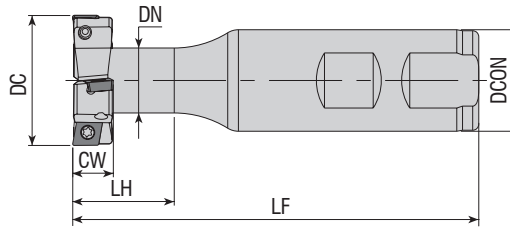

Código del Inserto Le Code de Commande Ordering Code	Stock Stock	Dimension (mm) Dimension (mm) Dimension (mm)							Inserto Plaquette Insert	Recambios / Pièces de Rechange / Spare Parts		
		ZEFP		DC	CW	DCON	LF	DN		LH	Tornillo Vis Screw	Llave Torx Clé Torx Torx Wrench
		Total Total	Eficaz Efficace Effective									
ATSM90-SP..05-D22.5X5-W25-L100-Z04	●	4	2	22.5	5	25	100	12	25	SPMG 050204 Para Inserto TGTC. POUR TGTC PLAQUETTES. FOR TGTC INSERT.	3006-M2x4	80-T06
ATSM90-SP..05-D30X5-W25-L100-Z04	●	4	2	30	5	25	100	10	25			
ATSM90-SPGT0502-D63X6-W32-L125-Z10	●	10	5	63	6	32	125	31	30	SPGT 050204		
ATSM90-SPGT0904-D32X14-W32-L120-Z04-H	●	4	2	32	14	32	120	17.5	30	SPGT 090408 Para Inserto ZCC. POUR ZCC PLAQUETTES. FOR ZCC INSERT.	4015-M3.5x9	80-T15
ATSM90-SPGT0904-D37X16-W32-L120-Z04-H	●	4	2	37	16	32	120	21	40			
ATSM90-SPGT0904-D42X17-W32-L120-Z04-H	●	4	2	42	17	32	120	21	40			
ATSM90-SPGT1104-D47X20-W32-L120-Z04-H	●	4	2	47	20	32	120	24	45	SPGT 110408	4015-M4x11	
ATSM90-SP..06-D80X7-W32-L120-Z10	●	10	5	80	7	32	120	32	30	SPMG 060204 Para Inserto TGTC. POUR TGTC PLAQUETTES. FOR TGTC INSERT.	3007-M2.2x5	80-T07

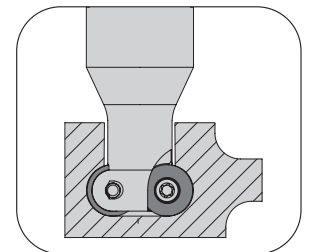
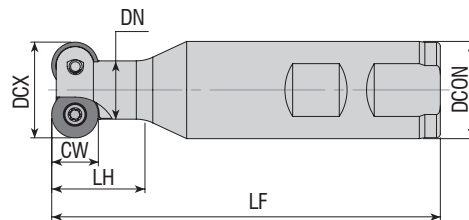

Código del Inserto Le Code de Commande Ordering Code	Stock Stock	Dimension (mm) Dimension (mm) Dimension (mm)							Inserto Plaquette Insert	Recambios / Pièces de Rechange / Spare Parts	
		ZEFP	DCX	CW	DCON	LF	DN	LH		Tornillo Vis Screw	Llave Torx Clé Torx Torx Wrench
ATSMR-RD0702-D17-W16-L90-Z02	●	2	17	7	16	90	10	12	RD.. 0702	3008-M2.5x6	80-T08
ATSMR-RD0702-D25-W16-L90-Z03	●	3	25	7	16	90	15	12			
ATSMR-RD0702-D35-W25-L100-Z05	●	5	35	7	25	100	20	20			
ATSMR-RD1003-D21-W25-L100-Z02	●	2	21	10	25	100	12	20	RD.. 1003	4015-M3.5x9	80-T15
ATSMR-RD1003-D80-W32-L165-Z06-H	●	6	80	10	32	165	30	31.5			
ATSMR-RD12T3-D25-W25-L100-Z02	●	2	25	12	25	100	15	24	RD.. 12T3	4015-M3.5x9	80-T15
ATSMR-RD12T3-D80-W32-L165-Z06-H	●	6	80	12	32	165	30	31.5			
ATSMR-RD1604-D34-W32-L110-Z02	●	2	34	16	32	110	20	30	RD.. 1604	4015-M4.5x11	

R: Derecha / Droite / Right L: Izquierda / Gauche / Left

● En Existencia / En stock / In Stock ○ Artículo sin Existencia / Indisponible en Stock / Non Stock Item
Compatible con el Inserto ISO. / Compatible avec ISO Plaquettes. / Compatible with ISO Insert.

Ejemplo de Pedido / Exemple de Commande / Ordering Example

1 Piezas / pcs. / pcs. ATSM90-SP..05-D22.5X5-W25-L100-Z04

Cálculo de Corte : S 369 / Calcul de Coupe : P 369 / Cutting Calculation : 369

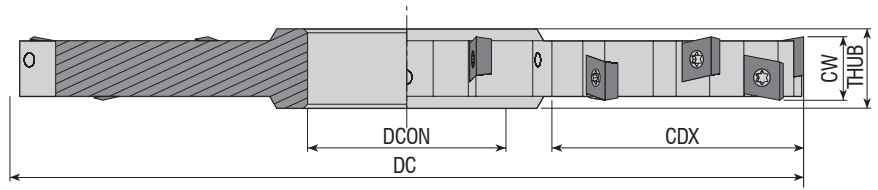

Código del Inserto Le Code de Commande Ordering Code	Stock Stock Stock	Dimension (mm) Dimension (mm) Dimension (mm)						Inserto Plaquette Insert	Recambios / Pièces de Rechange / Spare Parts		
		ZEFP		DC	CW	CDX	DCON		THUB	Tornillo Vis Screw	Llave Torx Clé Torx Torx Wrench
		Total Total	Eficaz Efficace								
ASDM-SPGT05-D80x6-d27-Z10	●	10	5	80	6	17	27	10	 SPGT 050204 Compatible con el Inserto ZCC. Compatible avec ZCC Plaquettes. FOR ZCC INSERT.	 3006-M2x4	 80-T06
ASDM-SPGT05-D100x6-d32-Z12	●	12	6	100	6	25	32	10			
ASDM-SPGT05-D125x6-d40-Z14	●	14	7	125	6	35	40	10			
ASDM-SPGT05-D160x6-d40-Z18	●	18	9	160	6	52	40	10			
ASDM-SPGT06-D80x7-d27-Z10	●	10	5	80	7	17	27	11	 SPGT 060204 Compatible con el Inserto ZCC. Compatible avec ZCC Plaquettes. FOR ZCC INSERT.	 3007-M2.2x5	 80-T07
ASDM-SPGT06-D100x7-d32-Z12	●	12	6	100	7	25	32	11			
ASDM-SPGT06-D125x7-d40-Z14	●	14	7	125	7	35	40	11			
ASDM-SPGT06-D160x7-d40-Z16	●	16	8	160	7	52	40	11			
ASDM-SPGT06-D200x7-d40-Z18	●	18	9	200	7	70	40	11	 SPGT 07T308	 3008-M2.5x6	 80-T08
ASDM-SPGT07-D100x10-d32-Z12	●	12	6	100	10	25	32	11			

R: Derecha / Droite / Right L: Izquierda / Gauche / Left
 ● En Existencia / En stock / In Stock ○ Artículo sin Existencia / Indisponible en Stock / Non Stock Item

Ejemplo de Pedido / Exemple de Commande / Ordering Example
 1 Piezas / pcs. / pcs. ASDM-SPGT05-D80x6-d27-Z10
 Cálculo de Corte : S 369 / Calcul de Coupe : P 369 / Cutting Calculation : 369



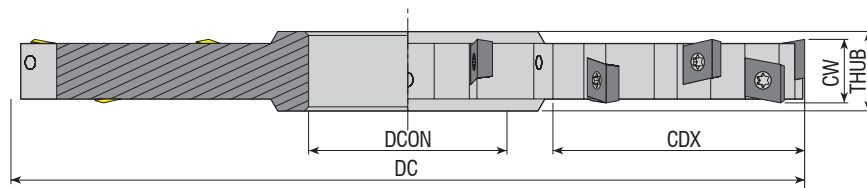

Código del Inserto Le Code de Commande Ordering Code	Stock Stock Stock	Dimension (mm) Dimension (mm) Dimension (mm)						Inserto Plaquette Insert	Recambios / Pièces de Rechange / Spare Parts		
		ZEFP		DC	CW	CDX	DCON		THUB	Tornillo Vis Screw	Llave Torx Clé Torx Torx Wrench
		Total Total	Eficaz Efficace								
ASDM-CC06-D80x8-d27-Z10	●	10	5	80	8	17	27	12	CC.T 0602.. Compatible con el Inserto ISO. Compatible avec ISO Plaquettes. FOR ISO INSERT.	3008-M2.5x6	80-T08
ASDM-CC06-D100x8-d32-Z12	●	12	6	100	8	25	32	12			
ASDM-CC06-D125x8-d40-Z14	●	14	7	125	8	35	40	12			
ASDM-CC06-D160x8-d40-Z16	●	16	8	160	8	52	40	12			
ASDM-CC06-D200x8-d40-Z18	●	18	9	200	8	70	40	12			
ASDM-CC06-D80x10-d27-Z10	●	10	5	80	10	17	27	14			
ASDM-CC06-D100x10-d32-Z12	●	12	6	100	10	25	32	14			
ASDM-CC06-D125x10-d40-Z14	●	14	7	125	10	35	40	14			
ASDM-CC06-D160x10-d40-Z16	●	16	8	160	10	52	40	14			
ASDM-CC06-D200x10-d40-Z18	●	18	9	200	10	70	40	14			
ASDM-CC09-D80x12-d27-Z08	●	8	4	80	12	17	27	16	CC.T 09T3.. Compatible con el Inserto ISO. Compatible avec ISO Plaquettes. FOR ISO INSERT.	4015-M3.5x11	80-T15
ASDM-CC09-D100x12-d32-Z10	●	10	5	100	12	25	32	16			
ASDM-CC09-D125x12-d40-Z12	●	12	6	125	12	35	40	16			
ASDM-CC09-D160x12-d40-Z14	●	14	7	160	12	52	40	16			
ASDM-CC09-D200x12-d40-Z16	●	16	8	200	12	70	40	16			
ASDM-CC09-D80x14-d27-Z08	●	8	4	80	14	17	27	18			
ASDM-CC09-D100x14-d32-Z10	●	10	5	100	14	25	32	18			
ASDM-CC09-D125x14-d40-Z12	●	12	6	125	14	35	40	18			
ASDM-CC09-D160x14-d40-Z14	●	14	7	160	14	52	40	18			
ASDM-CC09-D200x14-d40-Z16	●	16	8	200	14	70	40	18			
ASDM-CC12-D80x16-d27-Z06	●	6	3	80	16	17	27	20	CC.T 1204.. Compatible con el Inserto ISO. Compatible avec ISO Plaquettes. FOR ISO INSERT.	1020-M5x11	80-T20
ASDM-CC12-D100x16-d32-Z08	●	8	4	100	16	25	32	20			
ASDM-CC12-D125x16-d40-Z10	●	10	5	125	16	35	40	20			
ASDM-CC12-D160x16-d40-Z12	●	12	6	160	16	52	40	20			
ASDM-CC12-D200x16-d40-Z14	●	14	7	200	16	70	40	20			
ASDM-CC12-D80x18-d27-Z06	●	6	3	80	18	17	27	22			
ASDM-CC12-D100x18-d32-Z08	●	8	4	100	18	25	32	22			
ASDM-CC12-D125x18-d40-Z10	●	10	5	125	18	35	40	22			
ASDM-CC12-D160x18-d40-Z12	●	12	6	160	18	52	40	22			
ASDM-CC12-D200x18-d40-Z14	●	14	7	200	18	70	40	22			
ASDM-CC12-D250x18-d40-Z16	●	16	8	250	18	90	40	22			
ASDM-CC12-D80x20-d27-Z06	●	6	3	80	20	17	27	24			
ASDM-CC12-D100x20-d32-Z08	●	8	4	100	20	25	32	24			
ASDM-CC12-D125x20-d40-Z10	●	10	5	125	20	35	40	24			
ASDM-CC12-D160x20-d40-Z12	●	12	6	160	20	52	40	24			
ASDM-CC12-D200x20-d40-Z14	●	14	7	200	20	70	40	24			
ASDM-CC12-D250x20-d40-Z16	●	16	8	250	20	90	40	24			

R: Derecha / Droite / Right L: Izquierda / Gauche / Left

● En Existencia / En stock / In Stock ○ Artículo sin Existencia / Indisponible en Stock / Non Stock Item

Ejemplo de Pedido / Exemple de Commande / Ordering Example

1 Piezas / pcs. / pcs. ASDM-CC06-D80x8-d27-Z10

Cálculo de Corte : S 369 / Calcul de Coupe : P 369 / Cutting Calculation : 369

A-TIPO / TYPE A / A TYPE

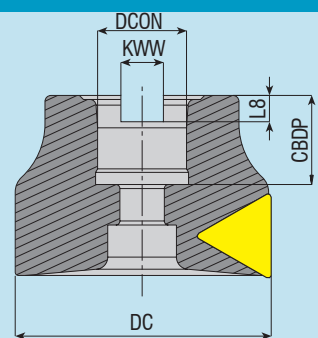

DC	DCON	DBC	KWW	L8	CBDP
40	16	-	8.4	5.6	20
50	22	-	10.4	6.3	22
63	22	-	10.4	6.3	22
80	27	-	12.4	7	25
100	32	-	14.4	8	26

B-TIPO / TYPE B / B TYPE

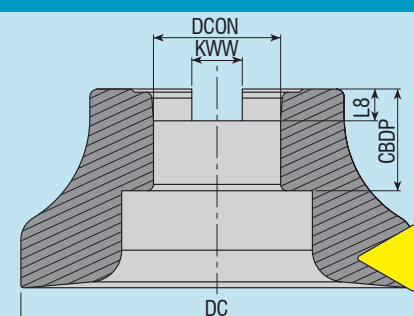

DC	DCON	DBC	KWW	L8	CBDP
125	40	-	16.4	9	32

C-TIPO / TYPE C / C TYPE

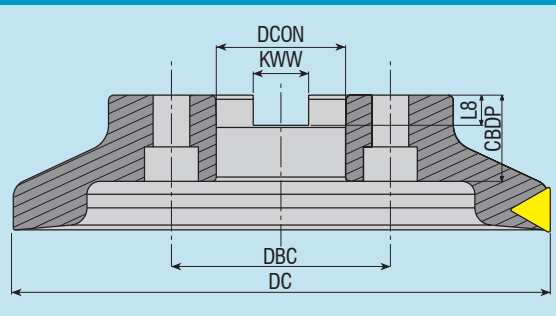

DC	DCON	DBC	KWW	L8	CBDP
160	40	66.7	16.4	9	32
200	60	101.6	25.7	14	40
250	60	101.6	25.7	14	40

D-TIPO / TYPE D / D TYPE

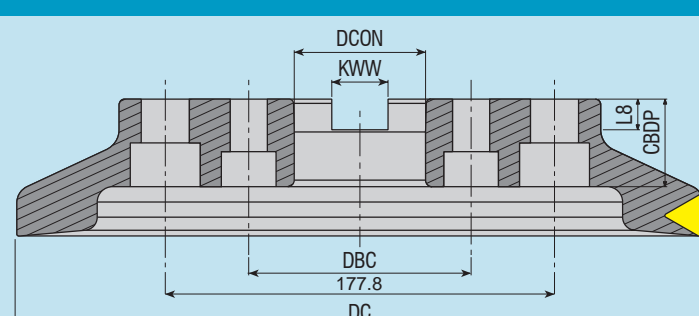

DC	DCON	DBC	KWW	L8	CBDP
315	60	101.6	25.7	14	40

GUÍA DEL USUARIO PARA U-DRILLS AKKO

Antes de conectar su taladro al torno CNC, debe verificar si la torre está descentrada. Si está descentrada no utilice el taladro en U. Para volver a centrar la torre:

1. Una parte cilíndrica cuya superficie es de precisión y cuya longitud y diámetro son los mismos con el taladro en U que utilizará, debe montarse en el soporte de la torreta y el valor X del torno debe ponerse a cero (0).
2. El comparador debe montarse en el portabrocas. El extremo del comparador debe ser contactado (tocado) a la superficie de la parte que montamos en la torreta.
3. El comparador que montamos en el portabrocas debe girarse 360° con el portabrocas y la torreta debe ponerse a cero girando de acuerdo con la velocidad variable del comparador.

VELOCIDAD DE CORTE Y REVOLUCIÓN QUE SE NECESITAN PARA UTILIZAR (EJECUTAR) SUS TALADROS EN U MÁS PRODUCTIVOS

Grupo No.	Material	Tipo de Material	Velocidad de corte Vc (m / m)
1	Acero no Aleado y Acero de Corte Libre	C1010. Automat etc.	220
2	Acero de Baja Aleación y Acero Fundido	C1030 - 106 vb.	200
3	Acero Aleado y Acero Para Herramientas	CK-45, 4140, 7131 vb.	170
4	Acero Para Trabajos en Caliente y Acero Inoxidable	Impax etc.	150

PD : La velocidad de corte puede estar relacionada con el tipo de inserto que utiliza. En primer lugar, elija el material para hacer el cálculo de la revolución. Debe multiplicar la velocidad de corte (Vc) del material que eligió por 1000 y dividir por 3.14. Debe dividir el valor que encontró por el diámetro de U-Drill. Por ejemplo:

Si nuestro material es acero aleado y acero para herramientas (tercer grupo), el diámetro del taladro en U es de 25 mm, la velocidad de corte es de 170, debemos calcular lo siguiente; $170 \times 1000 = 170000 / 3.14 = 54140$, $54140 / 25 = 2166$ rpm es el resultado que encontramos (velocidad del husillo) La velocidad de avance del torno se relaciona con el taladro en U que usará y cambia entre 0.05 y 0.10. El usuario lo configura según el corte del inserto de corte.

CÁLCULO DE ALIMENTACIÓN PARA LA MÁQUINA CENTRAL:

La velocidad del eje 2166, que encontramos como resultado del cálculo mencionado anteriormente, debe multiplicarse cortando la alimentación del inserto (mm / r) entre 0.05 y 0.10 opciones de alimentación. Ejemplo 1: $2166 \times 0.05 = 108$ Ejemplo 2: $2166 \times 0.10 = 217$ Los resultados 108 y 217 son el cálculo de avance mm / m para la máquina central.

GUIDE DE L'UTILISATEUR DE FORET AKKO

Avant de connecter votre FORET au tour CNC, vous devez vérifier si la tourelle n'est pas centrée. s'il est décentré, n'utilisez pas la foret.

Pour recentrer la tourelle:

1. Une pièce cylindrique qui a le même diamètre et la même longueur que le foret indexable sera attachée au support de la tourelle la valeur X de la machine est mise à zéro.
2. Un indicateur à cadran magnétique est placé dans le mandrin de la machine. La pointe de l'indicateur doit toucher la pièce que nous avons attachée à la tourelle.
3. L'indicateur à cadran magnétique et le mandrin doivent être tournés de 360 degrés ensemble, et la tourelle est réinitialisée en fonction du taux de changement de l'indicateur.

VITESSE DE COUPE ET RÉVOLUTION NÉCESSAIRES POUR UTILISER (FAIRE FONCTIONNER) VOS FORET U PLUS PRODUCTIVEMENT

Groupe No.	Matériel	Type de Matériau	Vitesse de coupe Vc (m / m)
1	En Acier Non Allié et Acier de Décolletage	C1010. Automat etc.	220
2	Acier Faiblement Allié, Acier Coulé	C1030 - 106 etc.	200
3	Acier Allié et Acier à Outils	CK-45, 4140, 7131 etc.	170
4	Acier pour travail à chaud et acier inoxydable	Impax etc.	150

Afin de calculer la rotation, sélectionnez d'abord le matériau. multipliez ensuite la vitesse de coupe (Vc) du matériau par 1000 et divisez-la par 3,14. divisez la valeur du résultat par le diamètre du foret.

Par exemple:

Si le matériau est de l'acier à outils et de fabrication (3e groupe), le diamètre du foret est de 25 mm, la vitesse de coupe est de 170, $170 \times 1000 = 170000 / 3,14 = 54140$, $54140 / 25 = 2166$ rotation (rotation de la broche de la machine). La vitesse d'avance des machines est également liée à l'insert utilisé qui varie entre 0,05 et 0,10. l'utilisateur ajuste cela en fonction de l'arête de coupe de la plaquette.

CALCUL DU TAUX D'ALIMENTATION DES CENTRES DE MACHINING

Sur les calculs ci-dessus, la révolution de la broche 2166 est multipliée par les options d'avance de la plaquette de coupe entre 0,05 et 0,10. (mm / tour). EXEMPLE 1: $2166 \times 0,05 = 108$ EXEMPLE 2: $2166 \times 0,10 = 217$ résultats sont des avances mm / minute les résultats 108 et 217 sont le calcul de l'avance mm / min pour les centres d'usinage.

Remarque: pour les forets en U D4 et plus longs, la pression intérieure de l'eau de refroidissement de la machine doit être d'au moins 6 bars.

USER'S GUIDE FOR AKKO U-DRILLS

Before connecting your drill to the CNC lathe, you need to check whether the turret is off-center. if it is off-center do not use the u-drill.

to recenter the turret:

1. A cylindrical piece that has the same diameter and length of the indexable drill, will be attached to the holder of the turret, and the X value of the machine is set to zero.
2. A magnet dial indicator is placed in the machine's chuck. The tip of the indicator must touch the piece we have attached to the turret.
3. The magnetic dial indicator and the chuck must be rotated 360 degrees together , and the turret is reset according to the rate of change in the indicator.

CUTTING SPEED AND REVOLUTION THAT ARE NEEDED FOR USING (RUNNING) YOUR U-DRILLS MORE PRODUCTIVELY

Grup No.	Material Type	Material Properties	Cutting Speed Vc (m/m)
1	Dead-mild work steel	C1010. Automat etc.	220
2	Manufactureing steel and casting material	C1030 - 106 etc.	200
3	Tool and Production Types	CK-45, 4140, 7131 etc.	170
4	Hot Work Steel and Stainless Steel	Impax etc.	150

In order to calculate the Rotation, first select the material. then multiply the cutting speed (Vc) of the material by 1000 and divide it by 3.14. divide the result value by the diameter of the drill. EXAMPLE: If the material is tool and manufacturing steel (3rd group), drill diameter is 25 mm, cutting speed is 170, $170 \times 1000 = 170000 / 3.14 = 54140$, $54140 / 25 = 2166$ rotation (Spindle Rotation of the Machine). The machines feed rate is also related to the used insert , which varies between 0.05 and 0.10. the user adjusts this according to the cutting edge of the insert.

FEED RATE CALCULARION FOR MACHINING CENTERS

On the above calculations, The 2166 spindle revolution is multiplied by the cutting insert feed options between 0.05 and 0.10. (mm / revolution). EXAMPLE 1: $2166 \times 0.05 = 108$ EXAMPLE 2: $2116 \times 0.10 = 217$ results are feed rate mm / minute the results 108 and 217 are the calculation of feed rate mm/min for machining centers.

Note: for D4 and longer U-drills inner Cooling water pressure of the machine must be minimum 6 bars.

PAR DE APRIETE RECOMENDADO - TORQUE DE SERRAGE RECOMMANDÉ RECOMMENDED TIGHTENING TORQUE

- Lea la Información a Continuación Antes de Apretar la Herramienta.
Lire des informations ci-dessous avant de serrer l'outil.
Read the Below Information Before Tighting the Tool.
- Compruebe el Tamaño Del Tornillo Del Juego de Tornillos y, Junto Con el Eje de Montaje, la Dimensión Interna de Los Tornillos.
Vérifiez la taille de la vis de l'outil de vissage et la taille de la vis interne du support avant de serrer.
Check the Screw-in Tool's Screw Size and the Internal Screw Size of the Holder Before Tightening.
- Cuando Apriete la Cabeza a Un Eje, Siga el Par de Apriete Relacionado En la Tabla.
Suivez les valeurs du tableau lors du serrage de l'outil dans le support.
Follow The Values in The Table When Tightening The Tool to Into The Holder.

Tornillo Vis Screw	Par (N.m) Couple (N.m) Torque (N.m)
M6	8
M8	23
M10	46
M12	80
M16	90



CÁLCULO DE VELOCIDAD Y VELOCIDAD DE ALIMENTACIÓN PARA PROCESO DE FRESADO

Vc.	S	D	F	Z	fz	FÓRMULAS
Velocidad de Corte (Lea Desde la Parte Posterior de la Caja de Inserción de Corte)	Revolución del Eje rpm	Diámetro de la Herramienta de Fresado	Velocidad de Alimentación	Número Efectivo de Dientes	Avance Por Diente (Lea Desde el Reverso de la Caja de Inserción de Corte)	Cálculo de la Revolución: $n = (vc \times 1000) / (3,14 \times D)$ Cálculo de Velocidad de Alimentación: $F = n \times Z \times fz$

Por ejemplo: realizaremos el fresado con una herramienta de fresado cuyo diámetro es D 50 mm, cuyo número es Z = 5. La revolución del husillo se escribió como Vc = 200 m / mn en la parte posterior de la caja de inserción de corte. Calculemos la revolución que debe ingresarse en la fresadora: $Vc = 200 \text{ m / mn}$ D = 50 mm S = Primero, la velocidad de corte se multiplica por 1000, el resultado debe dividirse por 3,14, el último resultado debe dividirse por el diámetro de herramienta de fresado. $S = 200 \times 1000 = 200000$ $200000 / 3,14 = 63663$ $63663/50 = 1273 \text{ rev}$ S = 1273 rev / mn Después de encontrar la revolución del husillo, busquemos la velocidad de avance: herramienta de fresado con Z = 5 dientes y leemos fz = 0,12 desde la parte posterior de la caja de inserción de corte. F = El número del diente debe multiplicarse con la revolución, el resultado debe multiplicarse con la alimentación por diente. $F = 1273 \times 5 = 6365$ $6365 \times 0,12 = 763$ F = 763 mm / mn Revolución que se debe ingresar a la fresadora = S 1273 Velocidad de avance que se debe ingresar a la fresadora = F 763 valor promedio.

P.S: Los valores Vc y fz deben escribirse en la parte posterior del inserto de corte. Si estos valores no se escribieron en el cuadro de inserción de corte, búsquelos en el catálogo de inserción de corte. Si el material que trabajará es acero, lea los valores de Vc y fz que se escribieron en la parte P, si es acero inoxidable, lea en la parte M, si es hierro fundido, lea en la parte K.

CALCUL DE VITESSE BROCHE ET AVANCE FRAISAGE

Vc.	S	D	F	Z	fz	FORMULES
Vitesse de coupe (S'il vous plaît lire la face arrière de la boîte d'insertion de coupe)	Broche Revolution rpm	Diamètre de Fraisage Outil	Avance	Nombre de Dents Efficace	Avance Par Dent (S'il Vous Plaît Lire à l'arrière Côté de Coupe Boîte D'insertion)	Calcul de la Révolution: $S = (Vc \times 1000) / (3,14 \times D)$ Flux de Calcul du Taux $F = S \times Z \times fz$

Par exemple: Nous allons faire le fraisage avec l'outil de fraisage dont diámetro est D 50 mm, dont le theeth numéroté Z = 5. La révolution broche a été écrit en tant que Vc = 200 m / mn au niveau du côté arrière de la pièce coupante rapportée boîte. Calculons la révolution qui devrait être saisi à la machine de fraisage: $Vc = 200 \text{ m / mn}$ D = 50 mm S = Vitesse de coupe est d'abord multiplié par 1000, le résultat devrait être divisé par 3,14, le dernier résultat doit être divisé par diamètre outil de fraisage. $S = 200 \times 1000 = 200000$ $200000 / 3,14 = 63663$ $63663/50 = 1273 \text{ tr}$ S = 1273 tr / mn Après avoir trouvé la révolution broche, Trouvons avance: outil de fraisage avec Z = 5 dents et nous avons lu fz = 0,12 depuis le côté arrière du boîtier de coupe plaquette. F = nombre de dents doivent être multipliées par la révolution, le résultat doit être multiplié par avance par dent. $F = 1273 \times 5 = 6365$ $6365 \times 0,12 = 763$ F = 763 mm / mn révolution qui doit être entrée à la machine de fraisage = S 1273 Débit d'alimentation qui doit être entré à la machine de fraisage = F 763 valeur moyenne.

P.S: Les valeurs Vc et fz doit être écrit sur le côté arrière de la plaquette de coupe. Si ces valeurs ne sont pas écrites sur la plaquette de coupe boîte, s'il vous plaît les trouver de coupe plaquette catalogue. Si le matériel que vous travaillerez est en acier, s'il vous plaît lire les valeurs Vc et fz qui ont été écrits sur la partie P, si elle est en acier inoxydable s'il vous plaît lire la partie M, si elle est en fonte s'il vous plaît lire la partie K.

CALCULATING SPINDLE SPEED and FEED RATE FOR MILLING PROCESS

Vc.	S	D	F	Z	fz	FORMULAS
Cutting Speed (Please read from the back-side of cutting insert box)	Spindle Revolution rpm	Milling Tool Diameter	Feed Rate	Number of Effective Tooth	Feed Per Tooth (Please Read From The Back Side of Cutting Insert Box)	Calculation of Revolution : $S = (Vc \times 1000) / (3,14 \times D)$ Feed Rate Calculation : $F = S \times Z \times fz$

For Example : We will make milling with milling tool whose diámetro is D 50 mm, whose theeth number is Z=5. The spindle revolution was written as $Vc=200\text{m/mn}$ at the back side of cutting insert box. Let's calculate the revolution that should be entered to the milling machine : $Vc=200 \text{ m/mn}$ D=50 mm
S = Firstly Cutting Speed is multiplied with 1000, the result should be divided by 3.14 , the last result should be divided by diameter of milling tool.

$S = 200 \times 1000 = 200000 \rightarrow 200000/3,14 = 63663 \rightarrow 63663/50 = 1273 \text{ rev}$ S=1273 rev / mn

After finding spindle revolution, let's find feed rate : milling tool with Z=5 teeth and we read fz=0,12 from the back side of cutting insert box.

F = Tooth number should be multiplied with revolution, the result should be multiplied with feed per tooth.

$F = 1273 \times 5 = 6365 \rightarrow 6365 \times 0,12 = 763$ F = 763 mm / mn

Revolution that should be entered to the milling machine = S 1273 Feed Rate that should be entered to the milling machine = F 763 average value.

P.S : The values Vc and fz has to be written at the back side of the cutting insert. If these values were not written on the cutting insert box, please find them from cutting insert catalogue. If the material that you will work is steel, please read Vc and fz values that were written on the part P, if it is stainless steel please read from the part M, if it is cast iron please read from the part K.

Guía de Aplicación de Barras de Mandrinar Internas, Relacionadas Con el Material del Cuerpo

Barres D'alésage Interieur Guide D'application, Liés au Matériel du Corps

Internal Boring Bars Application Guide, Related to Body Material

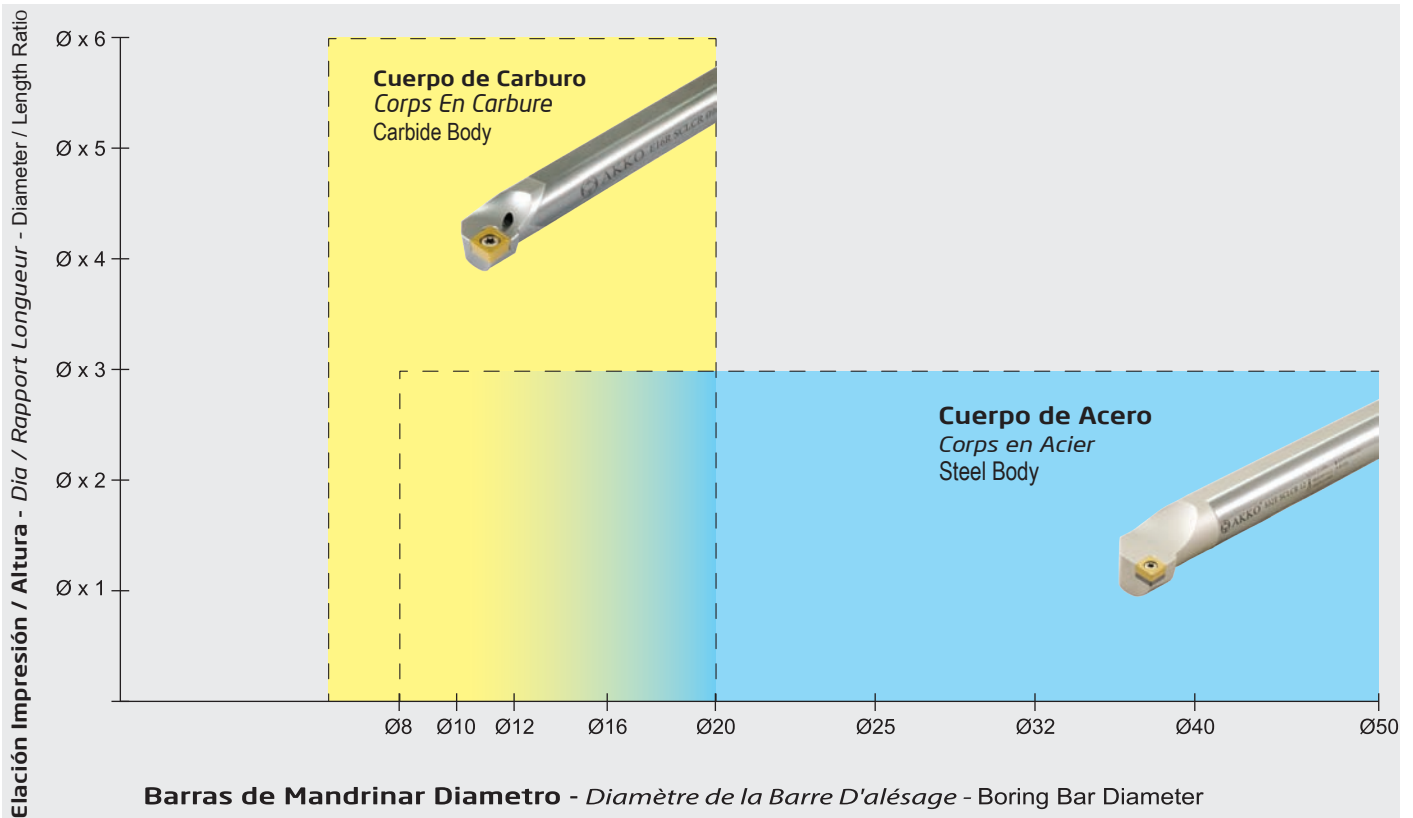

Guía de Aplicación Para Fresado Con Ranura en T

Guide D'application Pour Rainure en T

Application Guide For T-Slot Milling

Cuando se mecaniza acero con ranura en T, la pieza de trabajo debe mecanizarse como se muestra en el dibujo para garantizar una evacuación de viruta suave.

Ejemplo: antes de ranurar con la fresa de corte en T - código ATSM90-CC06-D32X10-W25-L100-Z04, el área del cuello de las herramientas que se va a trabajar y debe ser mecanizada por End-Mill. En este caso, es muy incorrecto mecanizar la ranura por completo. El área inferior ($0.8 \times b = 0.8 \times 10$) debe dejarse 8 mm sin mecanizar. La operación de esta área debe ser mecanizada por la fresa de ranura en T, que también es necesaria para el trabajo más saludable del portaherramientas.

Las ranuras a mecanizar deben estar libres de virutas para un mecanizado suave.

Lors du fraisage de rainures en T, la pièce à usiner doit être usinée comme indiqué sur l'image, pour une évacuation facile des copeaux.

Exemple: Avant de rainurer avec la fraise en T avec le code ATSM90-CC06- D32X10-W25- L100-Z04, le col de l'outil sera usiné avec une fraise en bout. Dans ce cas, il est très faux de traiter complètement le canal. La base ($0,8 \times b = 0,8 \times 10 = 8$ mm) doit être laissée non traitée. Le fraisage en T de cette zone est nécessaire pour que le moulin fonctionne plus correctement. Les fentes à usiner doivent être exemptes de copeaux pour un usinage en douceur.

Dans des rainures usinées, les copeaux doivent être retirés pour une découpe lisse.

In T-slot milling the workpiece should be machined as shown in the picture, for easy chip evacuation.

Example: Before grooving with the T mill with ATSM90-CC06- D32X10-W25- L100-Z04 code, the neck of the tool will be machined with an end mill. In this case, it is very wrong to process the channel completely. The base ($0.8 \times b = 0.8 \times 10 = 8$ mm) should be left untreated . T milling of this zone is necessary for the mill to work more properly.

Slots to be machined must be free from chips for smooth machining./in machined grooves, chips must be removed for soft cutting in .

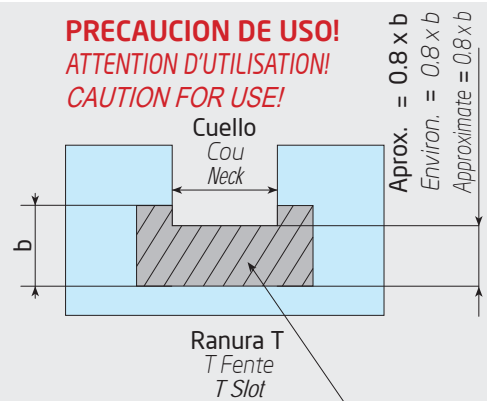

α = 5 Veces Mas de Vida / **α = Vie 5 Fois Plus Longue** / **α = 5 Times Long Life**

Ventajas de Revestimiento Alfa

Avantages Alpha
Revêtement
Alpha Coating
Advantages

- **Ventajas de recubrimiento alpha**
Haute résistance à l'abrasion
High wear resistance
- **Alta dureza superficial 750-800 Vickers**
Dureté de surface 750-800 Vickers
High surface hardness
750-800 Vickers
- **Alta resistencia a la abrasión**
Haute résistance à la tresse
High resistance to tempering
- **Alta resistencia a la fatiga**
Haute résistance à la fatigue
High fatigue resistance
- **Alta resistencia a la temperatura**
Haute résistance aux rayures et aux chocs
High scratch and notch resistance
- **Alta resistencia a la fatiga**
Résistance à la corrosion de l'acier non inoxydable
Higher corrosion resistance for non-stainless steels

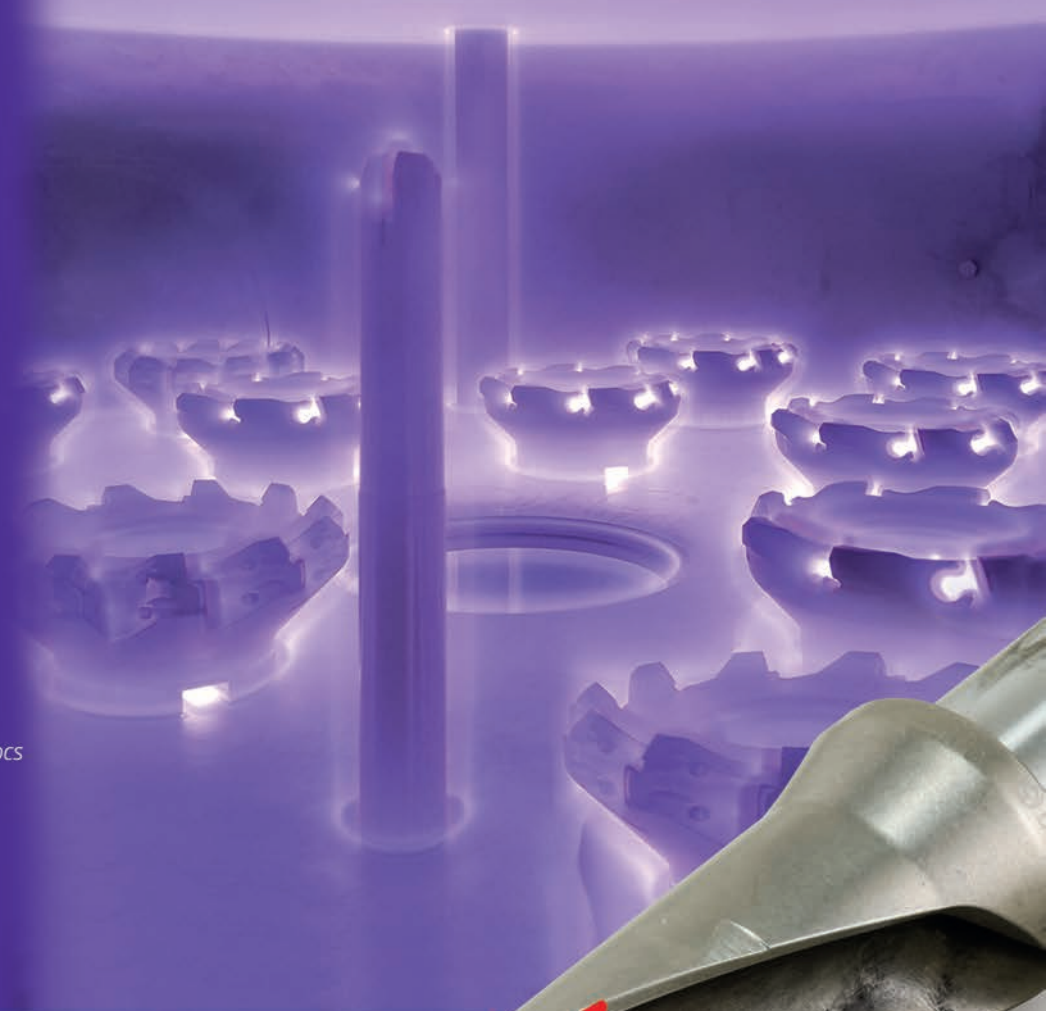

alta resistencia al roce y el impacto

plus une durée de vie...

longer tool life...













α resistencia a la corrosión . α est ami de l'environnement.
α is eco friendly.

No hace daño a la salud humana. C'est pas dangereux pour la sante humaine.
Is not harmful to human health.

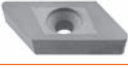
Mejor tornillo útil para la herramienta Gaz et autres déchets ne polluent pas l'environnement.
Gas and other wastes will not pollute the environment.

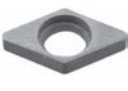
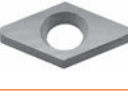
CUÑA / ASSISE / SHIMS

IMAGEN / IMAGE / PICTURE	CÓDIGO / CODE CODE	DETALLE DEL PRODUCTO / DÉTAILS DU PRODUIT PRODUCT DETAIL		
	AATN-2-0001	PARA SISTEMA-S / POUR SYSTEM S / FOR S SYSTEM	TCMT 16 CUÑA / ASSISE / SHIM	
	AATN-2-0002	PARA SISTEMA-T-M / POUR SYSTEM T-M / FOR T-M SYSTEM PARA SISTEMA-C / POUR SYSTEM C / FOR C SYSTEM	TNMG 16 CUÑA / ASSISE / SHIM TNGN 16 CUÑA / ASSISE / SHIM	
	AATN-3-0025	PARA SISTEMA-P / POUR SYSTEM P / FOR P SYSTEM	TNMG 16 CUÑA / ASSISE / SHIM	
	AATN-3-0015	PARA SISTEMA-T-M-P / POUR SYSTEM T-M-P / FOR T-M-P SYSTEM	TNMG 22 CUÑA / ASSISE / SHIM	
	AATN-2-0020	PARA ROSCADO 16 CUÑAS / ASSISE POUR FILETAGE 16 / THREADING 16 SHIM		
	AATN-2-0004	PARA ROSCADO 22 CUÑAS / ASSISE POUR FILETAGE 22 / THREADING 22 SHIM		
	ATS-16E	PARA ROSCADO 16 CUÑAS, EXTERNO DERECHO-INTERNO IZQUIERDO ASSISE POUR FILETAGE 16, DROIT Interieur Exterieur GAUCHE THREADING SYSTEM 16 SHIM, EXTERNAL RIGHT-INTERNAL LEFT		
	ATS-16I	PARA ROSCADO 16 CUÑAS, EXTERNO IZQUIERDO INTERNO DERECHO ASSISE POUR FILETAGE 16, Exterieur DROIT Interieur GAUCHE For THREADING SYSTEM 16 SHIM, EXTERNAL LEFT-INTERNAL RIGHT		
	ATS-22E	PARA ROSCADO 22 CUÑAS, EXTERNO DERECHO-INTERNO IZQUIERDO ASSISE POUR FILETAGE 22, DROIT Interieur Exterieur GAUCHE THREADING SYSTEM 22 SHIM, EXTERNAL RIGHT-INTERNAL LEFT		
	ATS-22I	PARA ROSCADO 22 CUÑAS, EXTERNO IZQUIERDO INTERNO DERECHO ASSISE POUR FILETAGE 22, Exterieur DROIT Interieur GAUCHE For THREADING SYSTEM 22 SHIM, EXTERNAL LEFT-INTERNAL RIGHT		
	ATS-27E	PARA ROSCADO 27 CUÑAS, EXTERNO DERECHO-INTERNO IZQUIERDO ASSISE POUR FILETAGE 27, DROIT Interieur Exterieur GAUCHE THREADING SYSTEM 27 SHIM, EXTERNAL RIGHT-INTERNAL LEFT		
	ATS-27I	PARA ROSCADO 27 CUÑAS, EXTERNO IZQUIERDO INTERNO DERECHO ASSISE POUR FILETAGE 27, Exterieur DROIT Interieur GAUCHE For THREADING SYSTEM 27 SHIM, EXTERNAL LEFT-INTERNAL RIGHT		
	AACN-2-0001	PARA SISTEMA-S / POUR SYSTEM S / FOR S SYSTEM PARA SISTEMA-T / POUR SYSTEM T / FOR T SYSTEM	CCMT 09 CUÑA / ASSISE / SHIM CNMG 09 CUÑA / ASSISE / SHIM	
	AACN-2-0002	PARA SISTEMA-P / POUR SYSTEM P / FOR P SYSTEM	CNMG 09 CUÑA / ASSISE / SHIM	
	AACN-2-0003	PARA SISTEMA-S / POUR SYSTEM S / FOR S SYSTEM	CCMT 12 CUÑA / ASSISE / SHIM	
	AACN-3-0001	PARA SISTEMA-T-M-P / POUR SYSTEM T-M-P / FOR T-M-P SYSTEM PARA SISTEMA-C / POUR SYSTEM C / FOR C SYSTEM	CNMG 12 CUÑA / ASSISE / SHIM CNGN 12 CUÑA / ASSISE / SHIM	
	AACN-3-0002	PARA SISTEMA-T-P / POUR SYSTEM T-P / FOR T-P SYSTEM	CNMG 16 CUÑA / ASSISE / SHIM	
	AACN-3-0003	PARA SISTEMA-T-P / POUR SYSTEM T-P / FOR T-P SYSTEM	CNMG 19 CUÑA / ASSISE / SHIM	
	AACN-3-0008	PARA SISTEMA-T-P / POUR SYSTEM T-P / FOR T-P SYSTEM	CNMG 25 CUÑA / ASSISE / SHIM	
		AAWN-2-0003	PARA SISTEMA-T-M-P / POUR SYSTEM T-M-P / FOR T-M-P SYSTEM	WNMG 08 CUÑA GRUESO / ASSISE EPAIS / THICK SHIM
AAWN-3-0001		PARA SISTEMA-T-M-P / POUR SYSTEM T-M-P / FOR T-M-P SYSTEM	WNMG 08 CUÑA / ASSISE / SHIM	
AAWN-SW317		PARA SISTEMA-T-M-P / POUR SYSTEM T-M-P / FOR T-M-P SYSTEM	WNMG 06 CUÑA / ASSISE / SHIM	
	AKS-16L	PARA SISTEMA-C / POUR SYSTEM C / FOR C SYSTEM	KNUX-L 16 CUÑA / ASSISE / SHIM	
	AKS-16R	PARA SISTEMA-C / POUR SYSTEM C / FOR C SYSTEM	KNUX-R 16 CUÑA / ASSISE / SHIM	
	AASD-3-0001	PARA FRESADO S-SISTEMA / POUR SYSTEM-S FRAISAGE For S-SYSTEM MILLING	SDMT 12 CUÑA / ASSISE / SHIM	
	AASE-3-0001	PARA FRESADO S-SISTEMA / POUR SYSTEM-S FRAISAGE For S-SYSTEM MILLING	SEMT 13 CUÑA / ASSISE / SHIM	
	AASN-2-0001	PARA SISTEMA-S / POUR SYSTEM S / FOR S SYSTEM	SCMT 09 CUÑA / ASSISE / SHIM	
	AASN-2-0002	PARA SISTEMA-P / POUR SYSTEM P / FOR P SYSTEM	SNMG 09 CUÑA / ASSISE / SHIM	
	AASN-2-0004	PARA SISTEMA-S / POUR SYSTEM S / FOR S SYSTEM	SCMT 12 CUÑA / ASSISE / SHIM	
	AASN-3-0004	PARA SISTEMA-T-P / POUR SYSTEM T-P / FOR T-P SYSTEM PARA SISTEMA-C / POUR SYSTEM C / FOR C SYSTEM	SNMG 12 CUÑA / ASSISE / SHIM SNGN 12 CUÑA / ASSISE / SHIM	
	AASN-3-0023	PARA SISTEMA-T-P / POUR SYSTEM T-P / FOR T-P SYSTEM	SNMG 15 CUÑA / ASSISE / SHIM	
	AASN-3-0005	PARA SISTEMA-T-P / POUR SYSTEM T-P / FOR T-P SYSTEM	SNMG 19 CUÑA / ASSISE / SHIM	
	AASN-3-0020	PARA SISTEMA-T-P / POUR SYSTEM T-P / FOR T-P SYSTEM	SNMG 25 CUÑA / ASSISE / SHIM	
	AASN-20020	PARA CARTUCHO PSDNN / POUR PSDNN CARTOUCHE FOR PSDNN CARTRIDGE	SNMG 12 CUÑA / ASSISE / SHIM	
		AADN-2-0001	PARA SISTEMA-S / POUR SYSTEM S / FOR S SYSTEM PARA SISTEMA-T / POUR SYSTEM T / FOR T SYSTEM	DCMT 11 CUÑA / ASSISE / SHIM DNMG 11 CUÑA / ASSISE / SHIM
		AADN-SD317	PARA SISTEMA-P / POUR SYSTEM P / FOR P SYSTEM	DNMG 11 CUÑA / ASSISE / SHIM
		AADN-3-0001	PARA SISTEMA-T-M-P / POUR SYSTEM T-M-P / FOR T-M-P SYSTEM PARA SISTEMA-C / POUR SYSTEM C / FOR C SYSTEM	DNMG 15 CUÑA / ASSISE / SHIM DNGN 15 CUÑA / ASSISE / SHIM
		AADN-2-0003	PARA SISTEMA-T / POUR SYSTEM T / FOR T SYSTEM	DNMG 15 CUÑA GRUESO / ASSISE EPAIS / THICK SHIM
AAVN-2-0002		PARA SISTEMA-S / POUR SYSTEM S / FOR S SYSTEM PARA SISTEMA-T / POUR SYSTEM T / FOR T SYSTEM	VBMT 16, VCMT 16 CUÑA / ASSISE / SHIM VNMG 16 CUÑA / ASSISE / SHIM	
AAVN-2-0003		PARA SISTEMA-S / POUR SYSTEM S / FOR S SYSTEM	VCMT 22 CUÑA / ASSISE / SHIM	
	AARC-3-0001	PARA SISTEMA-C / POUR SYSTEM C / FOR C SYSTEM	RCGX 06 CUÑA / ASSISE / SHIM	
	AARC-3-0002	PARA SISTEMA-C / POUR SYSTEM C / FOR C SYSTEM	RCGX 09 CUÑA / ASSISE / SHIM	
	AARC-3-0003	PARA SISTEMA-C / POUR SYSTEM C / FOR C SYSTEM	RCGX 12 CUÑA / ASSISE / SHIM	

ABRAZADERAS / BRIDES / WEDGES

IMAGEN / IMAGE / PICTURE	CÓDIGO / CODE CODE	DETALLE DEL PRODUCTO / DÉTAILS DU PRODUIT PRODUCT DETAIL	
	ATK-01	PARA SISTEMA-T / POUR SYSTEM T / FOR T SYSTEM	DNMG 11, WNMG 06, TNMG 16, CNMG 09 ABRAZADERA / BRIDE / WEDGE
	ATK-02	PARA SISTEMA-T / POUR SYSTEM T / FOR T SYSTEM	CNMG 12, WNMG 08, TNMG 22, DNMG 15, SNMG 12 ABRAZADERA / BRIDE / WEDGE
	ATK-03	PARA SISTEMA-T / POUR SYSTEM T / FOR T SYSTEM	VNMG 16 ABRAZADERA / BRIDE / WEDGE
	ATK-04	PARA SISTEMA-T / POUR SYSTEM T / FOR T SYSTEM	CNMG 16, SNMG 15 ABRAZADERA / BRIDE / WEDGE
	ATKH-01-R	PARA SISTEMA-T / POUR SYSTEM T / FOR T SYSTEM	CON AGUJERO DE REFRIGERANTE / AVEC TROU DE LIQUIDE DE REFROIDISSEMENT / WITH COOLANT HOLES
	ATKH-02-L	PARA SISTEMA-T / POUR SYSTEM T / FOR T SYSTEM	CON AGUJERO DE REFRIGERANTE / AVEC TROU DE LIQUIDE DE REFROIDISSEMENT / WITH COOLANT HOLES
	AMK-01	PARA SISTEMA-M / POUR SYSTEM M / FOR M SYSTEM	WNMG 06 ABRAZADERA / BRIDE / WEDGE
	AMK-02	PARA SISTEMA-M / POUR SYSTEM M / FOR M SYSTEM	INTERNO / Interieur / INTERNAL Ø20 TNMG 16, Ø25 MT-NR/L 16 ABRAZADERA / BRIDE / WEDGE
	AMK-03	PARA SISTEMA-M / POUR SYSTEM M / FOR M SYSTEM	DNMG 11, CNMG 12 ABRAZADERA / BRIDE / WEDGE
	AMK-04	PARA SISTEMA-M / POUR SYSTEM M / FOR M SYSTEM	DNMG 15, TNMG 16-22 ABRAZADERA / BRIDE / WEDGE
	AMK-05	PARA SISTEMA-M / POUR SYSTEM M / FOR M SYSTEM	WNMG 08 ABRAZADERA / BRIDE / WEDGE
	AMK-07	PARA SISTEMA-M / POUR SYSTEM M / FOR M SYSTEM	S20R MCLNR/L ABRAZADERA / BRIDE / WEDGE
	AMK-08	PARA SISTEMA-M / POUR SYSTEM M / FOR M SYSTEM	TNMG 22 ABRAZADERA / BRIDE / WEDGE
	ACK-01-R	PARA SISTEMA-C / POUR SYSTEM C / FOR C SYSTEM	KNUX-R ABRAZADERA / BRIDE / WEDGE
	ACK-02-L	PARA SISTEMA-C / POUR SYSTEM C / FOR C SYSTEM	KNUX-L ABRAZADERA / BRIDE / WEDGE
	ACK-03	PARA SISTEMA-C / POUR SYSTEM C / FOR C SYSTEM	154.91 EXTERNO E INTERNO / Extérieur ET Interieur / EXTERNAL and INTERNAL Ø25-Ø32 / ABRAZADERA / BRIDE / WEDGE
	ACK-04	PARA SISTEMA-C / POUR SYSTEM C / FOR C SYSTEM	CTFPR ABRAZADERA DE CARTUCHO / BRIDE POUR CARTOUCHE CARTRIDGE WEDGE
	ACK-05	PARA SISTEMA-P-C / POUR SYSTEM P-C / FOR P-C SYSTEM	ABRAZADERA PEQUEÑA ADICIONAL para ABRAZADERA DE FRESADO Y ROSCADO PETIT BRIDE SUPPLÉMENTAIRE pour LES BRIDES du FRAISAGE et RAINURAGE ADDITIONAL Wedge CLAMP for MILLING and THREADING TOOLS
	ACK-06	PARA SISTEMA-C / POUR SYSTEM C / FOR C SYSTEM	154.91 INTERNO / Interieur / INTERNAL Ø16-Ø20 ABRAZADERA / BRIDE / WEDGE
	ACK-07	PARA SISTEMA-C / POUR SYSTEM C / FOR C SYSTEM	JUEGO DE REPUESTOS DE CERAMICA CNGN, SNGN, DNGN ENSEMBLE DES PIECES DE RECHANGE EN CERAMIC CNGN, SNGN, DNGN SPARE PART SET OF CERAMIC CNGN, SNGN, DNGN
	ACK-08	PARA SISTEMA-C / POUR SYSTEM C / FOR C SYSTEM	JUEGO DE REPUESTOS DE CERAMICA TNGN, ENSEMBLE DES PIECES DE RECHANGE EN CERAMIC TNGN SPARE PART SET OF CERAMIC TNGN
	ACK-09	PARA SISTEMA-P / POUR SYSTEM P / FOR P SYSTEM	CNMG 16-19, SNMG 15-19 ZUSÄTZLICHE GROSSE KLEMMME GRANDE STAFFA-CUNEO ADDIZIONALE / ADDITIONAL BIG WEDGE
	ACK-10	PARA FRESADO C-SISTEMA / POUR SYSTEM C FRAISAGE FOR C-SYSTEM MILLING	SPKN 12, Ø50-Ø63 TPKN 16 ABRAZADERA / BRIDE / WEDGE (M8x8)
	ACK-11	PARA FRESADO C-SISTEMA / POUR SYSTEM C FRAISAGE FOR C-SYSTEM MILLING	Ø80-Ø100 TPKN 16-TPKN 22, OFKR 07, HNMX 09 ABRAZADERA / BRIDE / WEDGE (M8x10)
	ACK-12	PARA SISTEMA-C / POUR SYSTEM C / FOR C SYSTEM	CTSPR ABRAZADERA DE CARTUCHO / BRIDE POUR CARTOUCHE CARTRIDGE WEDGE
	ACK-15	PARA FRESADO S-SISTEMA / POUR SYSTEM-S FRAISAGE FOR S-SYSTEM MILLING	RD.. 10-12 ABRAZADERA / BRIDE / WEDGE
	ACK-19	PARA FRESADO S-SISTEMA / POUR SYSTEM-S FRAISAGE FOR S-SYSTEM MILLING	WD0805D ABRAZADERA / BRIDE / WEDGE
	ACK-21	PARA SISTEMA-C / POUR SYSTEM C / FOR C SYSTEM	SN.. 1204.. ABRAZADERA / BRIDE / WEDGE
	ACK-23	PARA SISTEMA-C / POUR SYSTEM C / FOR C SYSTEM	JUEGO DE REPUESTOS DE CERAMICA DNGN 11, ENSEMBLE DES PIECES DE RECHANGE EN CERAMIC DNGN 11 SPARE PART SET OF CERAMIC DNGN 11
	ACK-24	PARA FRESADO S-SISTEMA / POUR SYSTEM-S FRAISAGE FOR S-SYSTEM MILLING	XD0806D ABRAZADERA / BRIDE / WEDGE
	ACK-26	PARA SISTEMA-C / POUR SYSTEM C / FOR C SYSTEM	XNMG 0806.. ABRAZADERA / BRIDE / WEDGE
	ACK-27	PARA SISTEMA-C / POUR SYSTEM C / FOR C SYSTEM	RCGX 06 ABRAZADERA / BRIDE / WEDGE
	ACK-28	PARA SISTEMA-C / POUR SYSTEM C / FOR C SYSTEM	RCGX 09 ABRAZADERA / BRIDE / WEDGE
	ACK-29	PARA SISTEMA-C / POUR SYSTEM C / FOR C SYSTEM	RCGX 12 ABRAZADERA / BRIDE / WEDGE

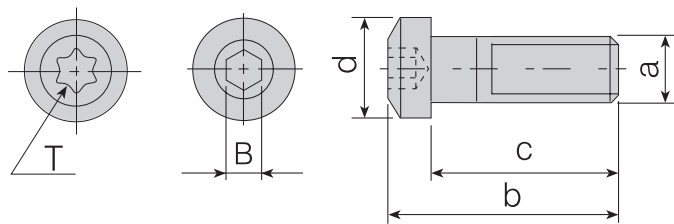
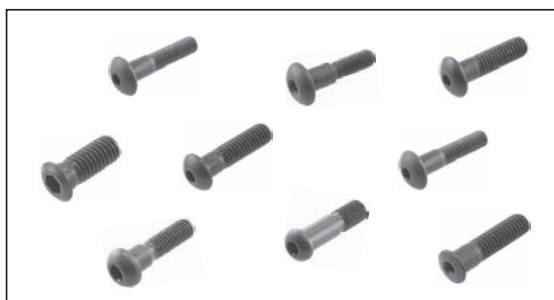

TORNILLO DE SUJECCIÓN / VIS DE SERRAGE / WEDGE SCREWS

Código del Inserto Le Code de Commande Ordering Code	a (M)	b	c	d	B(T)	Detalle Del Producto / Détails Du Produit / Product Detail	
						PARA SISTEMA-T / POUR SYSTEM T / FOR T-SYSTEM	PARA SISTEMA-M / POUR SYSTEM M / FOR M-SYSTEM
AKV-01-M5X22	M5x0.8	25.1	22	11	3	PARA SISTEMA-T / POUR SYSTEM T / FOR T-SYSTEM	DNMG 11, WNMG 06, TNMG 16
AKV-02-M6X22	M6x1.0	25.3	22	11	3	PARA SISTEMA-T / POUR SYSTEM T / FOR T-SYSTEM	CNMG 12, WNMG 08, TNMG 22, DNMG 15, SNMG 12, VNMG 16
						PARA RANURADO EXTERNO / POUR RAINURAGE EXTERIEUR FOR EXTERNAL GROOVING	2mm Tornillo de Herramientas de Ranurado Externo / Utlis Exterieurs Rainurage à Vis 2 mm External Grooving Tools Screw
AKV-03-M6X22	M6x1.0	25.3	22	10	3	PARA SISTEMA-M / POUR SYSTEM M / FOR M-SYSTEM	WNMG 08
AKV-04-M5X17	M5x0.8	20	17	8.5	3	PARA SISTEMA-M / POUR SYSTEM M / FOR M-SYSTEM	S20R MT-NR/L 16, S20R-S25S MWLNR/L 06, S25S MDUNR/L 11- Esterno / Esterne / External MWLNR 06
AKV-05-M6X25	M6x1.0	29.5	25	13.8	4	PARA SISTEMA-T / POUR SYSTEM T / FOR T-SYSTEM	Tornillos de Productos Antiguos / Vis Pour Ancients Produits / Old Products Screws CNMG 16, SNMG 15
AKV-06-M6X20	M6x1.0	26.5	20	10.6	4	PARA SISTEMA-C / POUR SYSTEM C / FOR C-SYSTEM	KNUX 16
AKV-07-M6X22	M6x1.0	23.5	22	8.5	3	PARA SISTEMA-C / POUR SYSTEM C / FOR C-SYSTEM	ADKT-154.91, AIKT-154.91-R/L-32
AKV-10-M6X14	M6x1.0	16	14	8.8	4	PARA SISTEMA-C / POUR SYSTEM C / FOR C-SYSTEM	AIKT-154.91-R/L-16, AIKT-154.91-R/L-20, AIKT-154.91-R/L-25
AKV-11-M8X29	M8x1.25	33.6	29	11	4	PARA SISTEMA-C / POUR SYSTEM C / FOR C-SYSTEM	TNGN 16, CNGN 12, DNGN 15, SNGN 12
AKV-17-M5X15	M5x0.8	18	15	8.55	3	PARA SISTEMA-M / POUR SYSTEM M / FOR M-SYSTEM	S16P MWLNR/L 06
AKV-19-M7X25	M7x1.0	29.6	25	14	4	PARA SISTEMA-T / POUR SYSTEM T / FOR T-SYSTEM	Nuevo / Nouveau / New CNMG 16, SNMG 15
AKV-20-M6X19	M6x1.0	22	19	11	3	PARA SISTEMA-M / POUR SYSTEM M / FOR M-SYSTEM	S25S MDUNR/L 15
AKV-21-M6X18	M6x1.0	20	18	8.5	3	PARA SISTEMA-C / POUR SYSTEM C / FOR C-SYSTEM	AIKT-154.91-R/L-25
AKV-23-M4X10	M4x0.7	12.2	10	7.4	15	PARA CARTUCHO / POUR CARTOUCHE / FOR CARTRIDGE	Tornillo de Fijación / Vis de Fixation / Mounting Screw
AKV-27-M6X20	M6x1.0	23.3	20	10	3	PARA SISTEMA-M / POUR SYSTEM M / FOR M-SYSTEM	S25S MWLNR/L 08
AKV-30-M6X22	M6x1.0	25.3	22	11	3	PARA SISTEMA-T / POUR SYSTEM T / FOR T-SYSTEM	Abrazadera de Cuñas / Mode de Fixation / Wedge Clamp
AKV-33-M6X22	M6x1.0	25.3	22	9.5	3	PARA SISTEMA-T / POUR SYSTEM T / FOR T-SYSTEM	Abrazadera de Cuñas / Mode de Fixation / Wedge Clamp

BOQUILLA DE REFRIGERANTE / BUSE DE LIQUIDE DE REFROIDISSEMENT / COOLANT NOZZLE

Imagen del Producto Image du Produit Product Picture	Código / Code / Code	Detalle Del Producto / Détails Du Produit / Product Detail	
		BOQUILLA DE REFRIGERANTE / BUSE DE LIQUIDE DE REFROIDISSEMENT / COOLANT NOZZLE	BOQUILLA DE REFRIGERANTE / BUSE DE LIQUIDE DE REFROIDISSEMENT / COOLANT NOZZLE
	AN-01	BOQUILLA DE REFRIGERANTE / BUSE DE LIQUIDE DE REFROIDISSEMENT / COOLANT NOZZLE	BOQUILLA DE REFRIGERANTE / BUSE DE LIQUIDE DE REFROIDISSEMENT / COOLANT NOZZLE

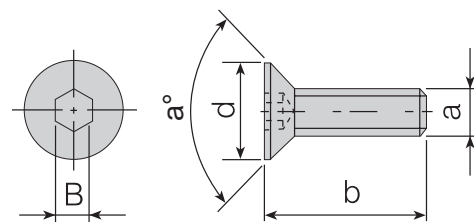

TORNILLO DE ABRAZADERA / VIS D'ASSISE / SHIM SCREWS

Código del Inserto Le Code de Commande Ordering Code	a (M)	b	d	B	a°	Detalle Del Producto / Détails Du Produit / Product Detail
AAV-01-M3x10	M3X0.5	10	5.9	2	90°	PARA SISTEMA-T / POUR SYSTEM T / FOR T-SYSTEM WNMG 06, KNUX 16
AAV-02-M5X12	M5X0.8	12	7	3	56°	PARA SISTEMA-T / POUR SYSTEM T / FOR T-SYSTEM CNMG 12, WNMG 08, TNMG 22, DNMG 15, SNMG 12
AAV-05-M6X15	M6X1.0	15	9	4	60°	PARA SISTEMA-T / POUR SYSTEM T / FOR T-SYSTEM CNMG 16, SNMG 15
AKV-12-M5X12	M5X0.8	12	7.8	3	90°	PARA SISTEMA-C / POUR SYSTEM C / FOR C-SYSTEM CTSPR Tornillo de Sujeción / Vis de Fixation / Wedge Screw
AKV-16-M6X16	M6X1.0	16	10	4	76°	PARA SISTEMA-C / POUR SYSTEM C / FOR C-SYSTEM CTFPR 13CS 16 Tornillo de Sujeción / Vis de Fixation / Wedge Screw
AAV-13-M5X8	M5X0.8	8	7	3	56°	PARA SISTEMA-T / POUR SYSTEM T / FOR T-SYSTEM S25S TSKNR/L 12, S25S TCLNR/L 12, S25S TWLNR/L 08, S25S TDUNR/L 15
AAV-14-M5X14	M5X0.8	14	8.8	3	45°	PARA ADCR / POUR ADCR / FOR ADCR ADCR Tornillo de Fijación / ADCR Vis de Fixation / ADCR Mounting Screw

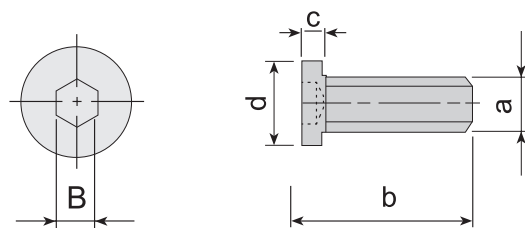

TORNILLO DE ABRAZADERA / VIS D'ASSISE / SHIM SCREWS

Código del Inserto Le Code de Commande Ordering Code	a (M)	b	c	d	B	Detalle Del Producto / Détails Du Produit / Product Detail
AAV-03-M5X12	M5X0.8	12	1.4	6	3	PARA SISTEMA-T / POUR SYSTEM T / FOR T-SYSTEM TNMG 16 PARA SISTEMA-C / POUR SYSTEM C / FOR C-SYSTEM TNGN 16
AAV-04-M5X12	M5X0.8	12	1.2	6.5	3	PARA SISTEMA-T / POUR SYSTEM T / FOR T-SYSTEM VNMG 16, DNMG 11, CNMG 09
AAV-09-M5X9	M5X0.8	9	1.4	6	3	PARA SISTEMA-T / POUR SYSTEM T / FOR T-SYSTEM S25S TCLNR/L 09, S25S TDUNR/L 11, S25S TDQNR/L 11

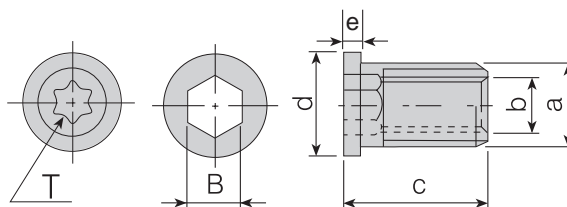

TORNILLOS BUKSE / VIS BUKSE / BUKSE SCREWS

Código del Inserto Le Code de Commande Ordering Code	a (M)	b	c	d	B(T)	e	Detalle Del Producto / Détails Du Produit / Product Detail
AAV-06-M3.5X11	M5x0.5	M3.5x0.6	11.3	6	3.5	1.2	PARA SISTEMA-S / POUR SYSTEM S / FOR S-SYSTEM CCMT 09, DCMT 11, VBMT 16, VCMT 16, TCMT 16, SCMT 09, 16 ER/L, 16 IR/L
AAV-07-M4.5X13	M6X0.75	M4.5X0.75	13	7.5	4.5	1.6	PARA SISTEMA-S / POUR SYSTEM S / FOR S-SYSTEM CCMT 12, SCMT 12, 22 ER/L, 22 IR/L
AAV-08-M3.5X8	M5X0.5	M3.5x0.6	8	6	20	1.2	PARA SISTEMA-S / POUR SYSTEM S / FOR S-SYSTEM Ø25 DCMT 11, Ø25-Ø32 CCMT 09, Ø25 TCMT 16, S25S-S32T SVJBR/L 16,
AAV-10-M4.5X8	M6X0.75	M4.5X0.75	8	7.5	4.5	1.05	PARA SISTEMA-S / POUR SYSTEM S / FOR S-SYSTEM Ø25-Ø32 CCMT 12, Ø25-Ø32 SCMT 12, SSDCN 1616 H12, SSSCR/L 1616 H12, SIR/L S25R 22
AAV-16-M3.5X8	M5X0.5	M3.5x0.6	8	6	20	1.1	PARA SISTEMA-S / POUR SYSTEM S / FOR S-SYSTEM SEMT 13

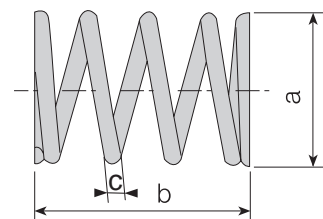
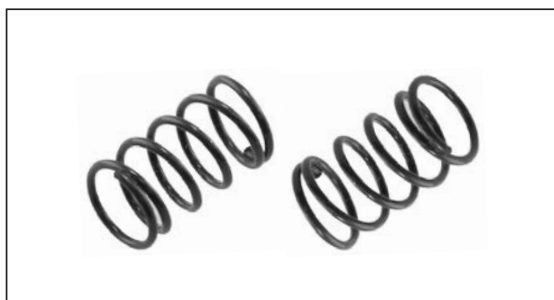

Código del Inserto Le Code de Commande Ordering Code				ABRAZADERA RESORTE / RESSORT A BRIDE / WEDGE SPRING	
a	b	c	Detalle Del Producto / Détails Du Produit / Product Detail		
AKY-01	7.7	11.2	0.9	PARA SISTEMA-T / POUR SYSTEM T / FOR T SYSTEM	CNMG 12, WNMG 08, TNMG 22, DNMG 15, SNMG 12, VNMG 16
AKY-02	8.5	13.5	0.7	PARA SISTEMA-C / POUR SYSTEM C / FOR C SYSTEM	KNUX 16

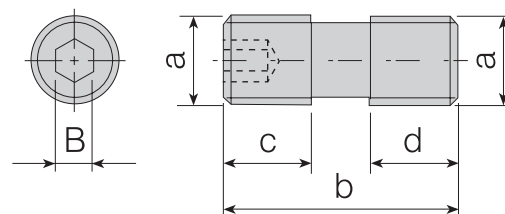

Código del Inserto Le Code de Commande Ordering Code						TORNILLO DE SUJECIÓN / VIS DE SERRAGE / WEDGE SCREWS	
a (M)	b	c	d	B	Detalle Del Producto / Détails Du Produit / Product Detail		
AKV-13-M8X1X16	M8x1.0	16	6.8	6.8	4	PARA FRESADO C-SISTEMA / POUR SYSTEM C FRAISAGE / MILLING FOR C-SYSTEM	SPKN 12, Ø63 TPKN 16
AKV-14-M8X1X18	M8x1.0	18	8	8	4	PARA FRESADO C-SISTEMA / POUR SYSTEM C FRAISAGE / MILLING FOR C-SYSTEM	Ø80-Ø100 TPKN 16, Ø63-Ø315 TPKN 22
AKV-15-M8X1X20	M8x1.0	20	8.5	8.5	4	PARA FRESADO C-SISTEMA / POUR SYSTEM C FRAISAGE / MILLING FOR C-SYSTEM	OFKR 07, HNMX 09
AKV-18-M5X14	M5x0.8	15	5	6.8	2.5	PARA FRESADO C-SISTEMA / POUR SYSTEM C FRAISAGE / MILLING FOR C-SYSTEM	SN19
AKV-22-M8X1X14	M8x1.0	14	6.8	4.8	4	PARA FRESADO C-SISTEMA / POUR SYSTEM C FRAISAGE / MILLING FOR C-SYSTEM	Ø50 TPKN 16
AKV-24-M6X1X18	M6x1.0	18	7.5	7.5	3	PARA FRESADO C-SISTEMA / POUR SYSTEM C FRAISAGE / MILLING FOR C-SYSTEM	SN.. 1204
AKV-26-M6X0.75X20	M6x0.75	20	8.5	8.5	3	PARA FRESADO C-SISTEMA / POUR SYSTEM C FRAISAGE / MILLING FOR C-SYSTEM	AFM45C-XN0806
AKV-28-M10x1.5x43	M10x1.5	43	18	18	5	WNMU 0907.. Ø50 TORNILLO DE FIJACIÓN / VIS DE FIXATION / MOUNTING SCREW	WNMU 0907.. Ø50

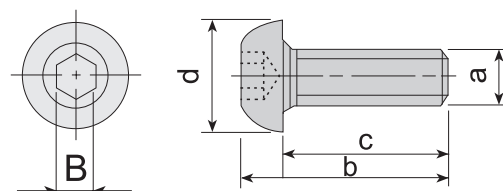

Código del Inserto Le Code de Commande Ordering Code	HERRAMIENTA DE RANURADO Y TORNILLOS DE ABRAZADERA / OUTIL GORGES ET VIS POUR BRIDE / GROOVING TOOL and CLAMP SCREWS					Detalle Del Producto / Détails Du Produit / Product Detail
	a (M)	b	c	d	B	
1904-M8X1X20	M8X1.0	25.9	20	11.3	4	PARA SISTEMA-S / POUR SYSTEM S / FOR S-SYSTEM RCMT 32 Tornillo / Vis / Screw
2004-M8X1X20	M8X1.0	25.9	20	11.4	4	PARA RANURADO EXTERNO / POUR RAINURAGE EXTERIEUR / FOR EXTERNAL GROOVING Tornillo de Herramientas de Ranurado Externo / Outils Exterieurs Rainurage à Vis / External Grooving Tools Screw
2004-M8X20	M8X1.25	30	25	25	4	PARA RANURADO EXTERNO / POUR RAINURAGE EXTERIEUR / FOR EXTERNAL GROOVING Herramientas de Ranurado Antiguas con Tornillo Externo Alle / Vieux Outils Exterieurs Rainurage Vis Alle / Old External Grooving Tools Screw Alle
AKV-08-M6X12	M6x1.0	17	12	14.3	4	PARA FRESADO C-SISTEMA / POUR RAINURAGE EXTERIEUR / MILLING FOR C-SYSTEM Tornillo de Sujeción / Vis de Fixation / Wedge Screw
AKV-09-M8X18	M8X1.0	24	18	17.2	5	PARA FRESADO C-SISTEMA / POUR RAINURAGE EXTERIEUR / MILLING FOR C-SYSTEM Tornillo de Sujeción / Vis de Fixation / Wedge Screw

Imagen del Producto Image du Produit Product Picture	PALANCAS / LEVIERS / LEVERS			Detalle Del Producto / Détails Du Produit / Product Detail
	Código / Code / Code			
	APL-01	PARA SISTEMA-P / POUR SYSTEM P / FOR P-SYSTEM	CNMG 09, DNMG 11, SNMG 09, TNMG 16, WNMG 06 PALANCA / LEVIER / LEVER	
	APL-02	PARA SISTEMA-P / POUR SYSTEM P / FOR P-SYSTEM	CNMG 12, SNMG 12, TNMG 22, WNMG 08 PALANCA / LEVIER / LEVER	
	APL-03	PARA SISTEMA-P / POUR SYSTEM P / FOR P-SYSTEM	DNMG 15 PALANCA / LEVIER / LEVER	
	APL-04	PARA SISTEMA-P / POUR SYSTEM P / FOR P-SYSTEM	CNMG 16, SNMG 15 PALANCA / LEVIER / LEVER	
	APL-05	PARA SISTEMA-P / POUR SYSTEM P / FOR P-SYSTEM	CNMG 19, SNMG 19 PALANCA / LEVIER / LEVER	
	APL-06	PARA SISTEMA-P / POUR SYSTEM P / FOR P-SYSTEM	CNMG 25, SNMG 25 PALANCA / LEVIER / LEVER	
	APL-07	PARA SISTEMA-P / POUR SYSTEM P / FOR P-SYSTEM	S16P PCLNR/L 09 PALANCA / LEVIER / LEVER	
	APL-08	PARA SISTEMA-P / POUR SYSTEM P / FOR P-SYSTEM	S16P PTUNR/L 16 PALANCA / LEVIER / LEVER	
	APL-11	PARA SISTEMA-P / POUR SYSTEM P / FOR P-SYSTEM	TNMG 11 PALANCA / LEVIER / LEVER	

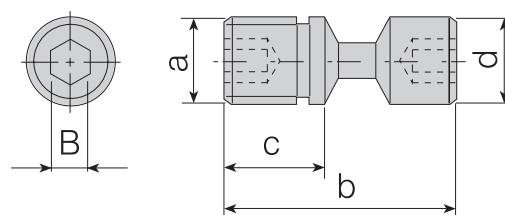

Código del Inserto Le Code de Commande Ordering Code	TORNILLOS DE PALANCA / VIS POUR LEVIER / LEVER SCREWS					Detalle Del Producto / Détails Du Produit / Product Detail
	a (M)	b	c	d	B	
ALV-01-M6X14	M6x1.0	14	10	5.85	2.5	PARA SISTEMA-P / POUR SYSTEM P / FOR P-SYSTEM S20R PCLNR/L 09, S20R PDUNR/L 11, S20R PDQNR/L 11, S20R PWNLR/L 06, S20R PTUNR/L 16
ALV-02-M6X17	M6x1.0	17	10	5.85	2.5	PARA SISTEMA-P / POUR SYSTEM P / FOR P-SYSTEM CNMG 09, DNMG 11, SNMG 09, TNMG 16, WNMG 06
ALV-03-M8X19	M8X1.0	19.8	11	7.9	3	PARA SISTEMA-P / POUR SYSTEM P / FOR P-SYSTEM CNMG 12, SNMG 12, TNMG 22, WNMG 08, DNMG 15
ALV-04-M8X22	M8X1.0	21.5	13	7.75	3	PARA SISTEMA-P / POUR SYSTEM P / FOR P-SYSTEM CNMG 16, SNMG 15
ALV-05-M10X27	M10X1.0	27.5	15	9.9	4	PARA SISTEMA-P / POUR SYSTEM P / FOR P-SYSTEM CNMG 19, SNMG 19
ALV-06-M12X36	M12X1.0	36	20	12	5	PARA SISTEMA-P / POUR SYSTEM P / FOR P-SYSTEM CNMG 25, SNMG 25
ALV-07-M6X13	M6X0.1	12.6	6.5	5.9	2.5	PARA SISTEMA-P / POUR SYSTEM P / FOR P-SYSTEM S16P PCLNR/L 09, S16P PTUNR/L 16
ALV-08-M8X16	M8X1.0	16	10	7.9	3	PARA SISTEMA-P / POUR SYSTEM P / FOR P-SYSTEM S25S PCLNR/L 12, S25S PDUNR/L 15, S25S PSKNR/L 12
ALV-10-M5X10	M5x0.8	10	4.6	4.9	2.5	PARA SISTEMA-P / POUR SYSTEM P / FOR P-SYSTEM TNMG 11,

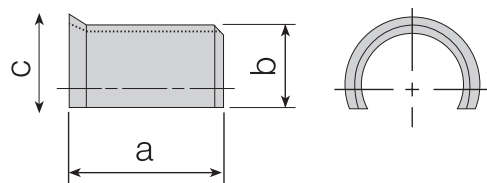

Código del Inserto Le Code de Commande Ordering Code	CUÑA RESORTE / RESSORT A ASSISE / SHIM SPRINGS			Detalle Del Producto / Détails Du Produit / Product Detail	
	a	b	c		
AA-01	5.6	4.9	6	PARA SISTEMA-P / POUR SYSTEM P / FOR P-SYSTEM	CNMG 09 ,DNMG 11, SNMG 09, TNMG 16, WNMG 06
AA-02	6	6.9	7.9	PARA SISTEMA-P / POUR SYSTEM P / FOR P-SYSTEM	CNMG 12, SNMG 12, TNMG 22, WNMG 08, DNMG 15
AA-03	8.9	8	9.5	PARA SISTEMA-P / POUR SYSTEM P / FOR P-SYSTEM	CNMG 16, SNMG 15
AA-04	11	9.8	10.7	PARA SISTEMA-P / POUR SYSTEM P / FOR P-SYSTEM	CNMG 19, SNMG 19
AA-05	12	13	15	PARA SISTEMA-P / POUR SYSTEM P / FOR P-SYSTEM	CNMG 25, SNMG 25
AA-07	5.6	4.9	6	PARA SISTEMA-P / POUR SYSTEM P / FOR P-SYSTEM	CNMG 09, TNMG 16

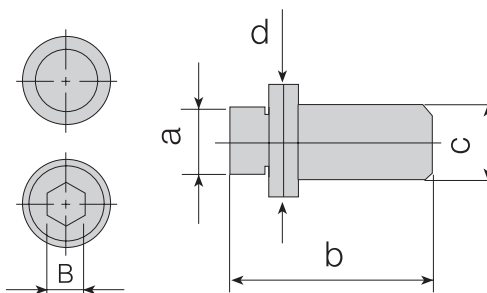
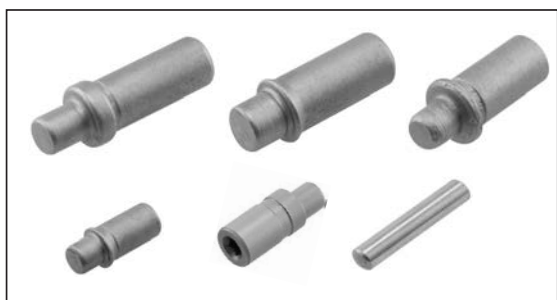

Código del Inserto Le Code de Commande Ordering Code	PINS / ÉPINGLES / PINS					Detalle Del Producto / Détails Du Produit / Product Detail	
	a	b	c	d	B		
APM-01	3.55	18	5	6	-	PARA SISTEMA-M / POUR SYSTEM M / FOR M-SYSTEM	Interno / Interieur / Internal Ø32-Ø40 TNMG 16 Externo / Esterne / External TNMG 16
APM-02	5	18	6	7.3	-	PARA SISTEMA-M / POUR SYSTEM M / FOR M-SYSTEM	TNMG 22, WNMG 08
APM-03	3.5	12	5	6.5	-	PARA SISTEMA-M / POUR SYSTEM M / FOR M-SYSTEM	S20R MTFNR/L 16, S20R MT-NR/L 16, S20R MTUNR/L 16, S20R MTQNR/L 16, S20R MDUNR/L 11
APM-04	5	15	6	7.3	-	PARA SISTEMA-M / POUR SYSTEM M / FOR M-SYSTEM	S32T MCLNR/L 12, DNMG 15, S25S MWLNR/L 08
APM-05	5	11.5	6.5	6.5	3	PARA SISTEMA-M / POUR SYSTEM M / FOR M-SYSTEM	MSYNR 11.5CS 12 Para Cartucho / Pour Cartouche / For Cartridge
APM-06	3	15.7	-	-	-	PARA SISTEMA-C / POUR SYSTEM C / FOR C-SYSTEM	154.91
APM-07	3.5	11.5	6.5	6.5	3	PARA SISTEMA-M / POUR SYSTEM M / FOR M-SYSTEM	S20R ET-NR 16
APM-08	3.5	12	5	5.4	-	PARA SISTEMA-M / POUR SYSTEM M / FOR M-SYSTEM	S25S MWLNR/L 06, Externo / Esterne / External
APM-09	3.5	10	5	5.4	-	PARA SISTEMA-M / POUR SYSTEM M / FOR M-SYSTEM	S16P MWLNR/L 06
APM-10	3.5	11	5	5.4	-	PARA SISTEMA-M / POUR SYSTEM M / FOR M-SYSTEM	S20R MWLNR/L 06
APM-11	3.5	11	5	6.5	-	PARA SISTEMA-M / POUR SYSTEM M / FOR M-SYSTEM	S20R MTQNR/L 16
APM-12	5	12	6	7.3	-	PARA SISTEMA-M / POUR SYSTEM M / FOR M-SYSTEM	S20R MCLNR/L 12, S25S MCLNR/L 12-Z
APM-13	5	14	6	7.3	-	PARA SISTEMA-M / POUR SYSTEM M / FOR M-SYSTEM	S25S MCLNR/L 12
APM-14	3.55	15	5	6	-	PARA SISTEMA-M / POUR SYSTEM M / FOR M-SYSTEM	S25S MTFNR/L 16, S25S MT-NR/L 16, S25S MTUNR/L 16, S25S MTQNR/L 16
APM-15	4.40	16	6.40	6.40	3	PARA SISTEMA-M / POUR SYSTEM M / FOR M-SYSTEM	MSYNR 16CS 12 Para Cartucho / Pour Cartouche / For Cartridge

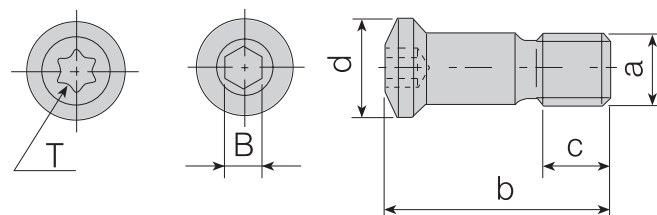

Código del Inserto
Le Code de Commande
Ordering Code

TORNILLOS NARIZ DE BOLA / VITI PER SEMISFERICHE / BALL NOSE SCREWS

Detalle Del Producto / Détails Du Produit / Product Detail

	a (M)	b	c	d	B(T)		
1208-M3x7	M3x0.5	6.9	2.7	4.1	8	TORNILLOS NARIZ DE BOLA / VIS SPHERIQUE / BALL NOSE SCREW	P3208
1215-M4X0.5X9	M4X0.5	8.6	3.2	5.75	15	SCHRAUBE FÜR KUGELKOPFFRÄSER / VIS SPHERIQUE / BALL NOSE SCREW	P3210-ROHX 12
1220-M5X0.5X9	M5X0.5	9.6	3.4	6.8	20	SCHRAUBE FÜR KUGELKOPFFRÄSER / VIS SPHERIQUE / BALL NOSE SCREW	P3212
1220-M5X0.5X12	M5X0.5	12.9	4.4	7.4	20	SCHRAUBE FÜR KUGELKOPFFRÄSER / VIS SPHERIQUE / BALL NOSE SCREW	P3216-ROHX 16
1220-M5X0.5X15	M5X0.5	16.4	6	7.8	20	SCHRAUBE FÜR KUGELKOPFFRÄSER / VIS SPHERIQUE / BALL NOSE SCREW	P3220-ROHX 20
1220-M6X0.75X20	M6X0.75	20	6	9.4	20	SCHRAUBE FÜR KUGELKOPFFRÄSER / VIS SPHERIQUE / BALL NOSE SCREW	P3225
1204-M8X0.75X26	M8X0.75	26	7.5	12	4	SCHRAUBE FÜR KUGELKOPFFRÄSER / VIS SPHERIQUE / BALL NOSE SCREW	P3232
1210-M3.5X9.6	M3.5X0.6	9.6	4	4.7	10	SCHRAUBE FÜR KUGELKOPFFRÄSER / VIS SPHERIQUE / BALL NOSE SCREW	BNM 12
1215-M4X13.5	M4X0.7	13.5	5	5.8	15	SCHRAUBE FÜR KUGELKOPFFRÄSER / VIS SPHERIQUE / BALL NOSE SCREW	BNM 16

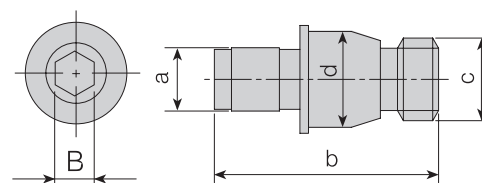

Código del Inserto
Le Code de Commande
Ordering Code

TORNILLO ECCENTRICO / VIS EXCENTRIQUE / ECCENTRIC SCREW

Detalle Del Producto / Détails Du Produit / Product Detail

	a	b	c	d	B		
AEV-01-M6x16	4.85	16	M6x1.0	6.5	2.5	Tornillo Eccentrico / Vis Excentrique / Eccentric Screw	PSDNN Para Cartucho / Pour Cartouche / For Cartridge

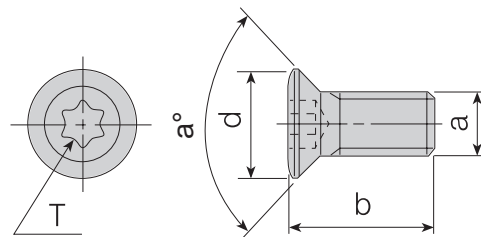

Código del Inserto
 Le Code de Commande
 Ordering Code

TORNILLO TORX / VIS TORX / TORX SCREW

Detalle Del Producto / Détails Du Produit / Product Detail

	a (M)	b	T	d	a°		
4006-M1.6x3.2	M1.6X0.35	3.2	6	2.5	60	PARA SISTEMA-S / POUR SYSTEM S / FOR S-SYSTEM	TORNILLO TORX / VIS TORX / TORX SCREW
3006-M1.8x4	M1.8X0.35	4	6	2.45	60	PARA SISTEMA-S / POUR SYSTEM S / FOR S-SYSTEM	TORNILLO TORX / VIS TORX / TORX SCREW
3006-M2x3.1	M2X0.4	3.1	6	2.7	60	PARA SISTEMA-S / POUR SYSTEM S / FOR S-SYSTEM	TORNILLO TORX / VIS TORX / TORX SCREW
3006-M2x3.3	M2X0.4	3.3	6	2.7	60	PARA SISTEMA-S / POUR SYSTEM S / FOR S-SYSTEM	TORNILLO TORX / VIS TORX / TORX SCREW
3006-M2X3.6	M2X0.4	3.6	6	2.7	60	PARA SISTEMA-S / POUR SYSTEM S / FOR S-SYSTEM	TORNILLO TORX / VIS TORX / TORX SCREW
3006-M2x4	M2X0.4	4.3	6	2.7	60	PARA SISTEMA-S / POUR SYSTEM S / FOR S-SYSTEM	TORNILLO TORX / VIS TORX / TORX SCREW
4006-M2x5	M2X0.4	5	6	3	55	PARA SISTEMA-S / POUR SYSTEM S / FOR S-SYSTEM	TORNILLO TORX / VIS TORX / TORX SCREW
3007-M2.2x5	M2.2X0.45	5.2	7	3.15	60	PARA SISTEMA-S / POUR SYSTEM S / FOR S-SYSTEM	TORNILLO TORX / VIS TORX / TORX SCREW
4006-M2.2x5	M2.2X0.45	5	6	2.8	55	PARA SISTEMA-S / POUR SYSTEM S / FOR S-SYSTEM	TORNILLO TORX / VIS TORX / TORX SCREW
1008-M2.5x5	M2.5X0.45	5.5	8	3.5	45	PARA SISTEMA-S / POUR SYSTEM S / FOR S-SYSTEM	TORNILLO TORX / VIS TORX / TORX SCREW
1008-M2.5x7	M2.5X0.45	7	8	3.6	45	PARA SISTEMA-S / POUR SYSTEM S / FOR S-SYSTEM	TORNILLO TORX / VIS TORX / TORX SCREW
1108-M2.5x6	M2.5X0.45	6	8	3.9	R	PARA SISTEMA-S / POUR SYSTEM S / FOR S-SYSTEM	TORNILLO TORX / VIS TORX / TORX SCREW
3008-M2.5x5	M2.5X0.45	5	8	3.5	60	PARA SISTEMA-S / POUR SYSTEM S / FOR S-SYSTEM	TORNILLO TORX / VIS TORX / TORX SCREW
3008-M2.5x6	M2.5X0.45	6		3.5	60	PARA SISTEMA-S / POUR SYSTEM S / FOR S-SYSTEM	TORNILLO TORX / VIS TORX / TORX SCREW
3008-M2.5X8	M2.5X0.45	8	8	3.5	50	PARA SISTEMA-S / POUR SYSTEM S / FOR S-SYSTEM	TORNILLO TORX / VIS TORX / TORX SCREW
4008-M2.5x4	M2.5X0.45	4	8	3.5	45	PARA SISTEMA-S / POUR SYSTEM S / FOR S-SYSTEM	TORNILLO TORX / VIS TORX / TORX SCREW
4008-M2.5x4.5	M2.5X0.45	4.5	8	3.5	45	PARA SISTEMA-S / POUR SYSTEM S / FOR S-SYSTEM	TORNILLO TORX / VIS TORX / TORX SCREW
4008-M2.5x6	M2.5X0.45	5.8	8	3.5	45	PARA SISTEMA-S / POUR SYSTEM S / FOR S-SYSTEM	TORNILLO TORX / VIS TORX / TORX SCREW
4008-M2.5x6.5	M2.5X0.45	6.5	8	4	60	PARA SISTEMA-S / POUR SYSTEM S / FOR S-SYSTEM	TORNILLO TORX / VIS TORX / TORX SCREW
4108-M2.5x6.5	M2.5X0.45	6.5	8	3.5	50	PARA SISTEMA-S / POUR SYSTEM S / FOR S-SYSTEM	TORNILLO TORX / VIS TORX / TORX SCREW
4108-M2.5x8	M2.5X0.45	8	8	3.5	50	PARA SISTEMA-S / POUR SYSTEM S / FOR S-SYSTEM	TORNILLO TORX / VIS TORX / TORX SCREW
1008-M3x6	M3X0.5	6	8	4	60	PARA SISTEMA-S / POUR SYSTEM S / FOR S-SYSTEM	TORNILLO TORX / VIS TORX / TORX SCREW
1008-M3x8	M3X0.5	8	8	3.9	60	PARA SISTEMA-S / POUR SYSTEM S / FOR S-SYSTEM	TORNILLO TORX / VIS TORX / TORX SCREW
1108-M3x6.8	M3X0.5	6.8	8	4	60	PARA SISTEMA-S / POUR SYSTEM S / FOR S-SYSTEM	TORNILLO TORX / VIS TORX / TORX SCREW
3008-M3x6	M3X0.5	6	8	4	45	PARA SISTEMA-S / POUR SYSTEM S / FOR S-SYSTEM	TORNILLO TORX / VIS TORX / TORX SCREW
3008-M3x7	M3X0.5	7	8	4	55	PARA SISTEMA-S / POUR SYSTEM S / FOR S-SYSTEM	TORNILLO TORX / VIS TORX / TORX SCREW
3008-M3x8	M3X0.5	8	8	4	45	PARA SISTEMA-S / POUR SYSTEM S / FOR S-SYSTEM	TORNILLO TORX / VIS TORX / TORX SCREW
3108-M3x6	M3X0.5	6	8	3.8	60	PARA SISTEMA-S / POUR SYSTEM S / FOR S-SYSTEM	TORNILLO TORX / VIS TORX / TORX SCREW
3108-M3x8	M3X0.5	8	8	3.8	60	PARA SISTEMA-S / POUR SYSTEM S / FOR S-SYSTEM	TORNILLO TORX / VIS TORX / TORX SCREW
4008-M3x8	M3X0.5	8	8	4	60	PARA SISTEMA-S / POUR SYSTEM S / FOR S-SYSTEM	TORNILLO TORX / VIS TORX / TORX SCREW
4010-M3x6	M3X0.5	6	10	4.2	45	PARA SISTEMA-S / POUR SYSTEM S / FOR S-SYSTEM	TORNILLO TORX / VIS TORX / TORX SCREW
4010-M3x8	M3X0.5	8	10	4.2	45	PARA SISTEMA-S / POUR SYSTEM S / FOR S-SYSTEM	TORNILLO TORX / VIS TORX / TORX SCREW
1015-M3.5x9	M3.5X0.6	9	15	5.3	60	PARA SISTEMA-S / POUR SYSTEM S / FOR S-SYSTEM	TORNILLO TORX / VIS TORX / TORX SCREW
1015-M3.5x11	M3.5X0.6	11.1	15	5.3	60	PARA SISTEMA-S / POUR SYSTEM S / FOR S-SYSTEM	TORNILLO TORX / VIS TORX / TORX SCREW
1015-M3.5x14	M3.5X0.6	14	15	5.3	66	PARA SISTEMA-S / POUR SYSTEM S / FOR S-SYSTEM	TORNILLO TORX / VIS TORX / TORX SCREW
1015-M3.5x16	M3.5X0.6	16	15	5.3	55	PARA SISTEMA-S / POUR SYSTEM S / FOR S-SYSTEM	TORNILLO TORX / VIS TORX / TORX SCREW
1315-M3.5x11	M3.5X0.6	10.6	15	7.9	-	PARA SISTEMA-S / POUR SYSTEM S / FOR S-SYSTEM	TORNILLO TORX / VIS TORX / TORX SCREW
1510-M3.5x7	M3.5X0.6	7.1	10	5.1	55	PARA SISTEMA-S / POUR SYSTEM S / FOR S-SYSTEM	TORNILLO TORX / VIS TORX / TORX SCREW
1510-M3.5x9	M3.5X0.6	9.1	10	5	55	PARA SISTEMA-S / POUR SYSTEM S / FOR S-SYSTEM	TORNILLO TORX / VIS TORX / TORX SCREW
1615-M3.5x10	M3.5X0.6	10	15	5.8	60	PARA SISTEMA-S / POUR SYSTEM S / FOR S-SYSTEM	TORNILLO TORX / VIS TORX / TORX SCREW
1615-M3.5x11	M3.5X0.6	11	15	5.8	60	PARA SISTEMA-S / POUR SYSTEM S / FOR S-SYSTEM	TORNILLO TORX / VIS TORX / TORX SCREW
1615-M3.5x15	M3.5X0.6	15	15	5.8	60	PARA SISTEMA-S / POUR SYSTEM S / FOR S-SYSTEM	TORNILLO TORX / VIS TORX / TORX SCREW
3010-M3.5x7	M3.5X0.6	7	10	5	55	PARA SISTEMA-S / POUR SYSTEM S / FOR S-SYSTEM	TORNILLO TORX / VIS TORX / TORX SCREW
3010-M3.5x9	M3.5X0.6	9	10	5	55	PARA SISTEMA-S / POUR SYSTEM S / FOR S-SYSTEM	TORNILLO TORX / VIS TORX / TORX SCREW
3015-M3.5x9	M3.5X0.6	8.8	15	5.4	60	PARA SISTEMA-S / POUR SYSTEM S / FOR S-SYSTEM	TORNILLO TORX / VIS TORX / TORX SCREW
4015-M3.5x8	M3.5X0.6	7.9	15	5.3	55	PARA SISTEMA-S / POUR SYSTEM S / FOR S-SYSTEM	TORNILLO TORX / VIS TORX / TORX SCREW
4015-M3.5x9	M3.5X0.6	8.7	15	5.3	60	PARA SISTEMA-S / POUR SYSTEM S / FOR S-SYSTEM	TORNILLO TORX / VIS TORX / TORX SCREW
4015-M3.5x10	M3.5X0.6	9.8	15	5.3	60	PARA SISTEMA-S / POUR SYSTEM S / FOR S-SYSTEM	TORNILLO TORX / VIS TORX / TORX SCREW

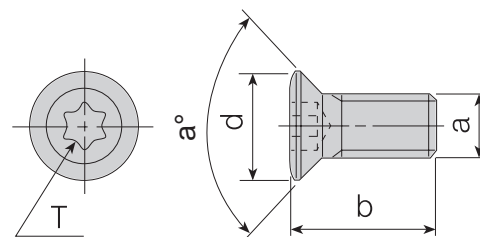

TORNILLO TORX / VIS TORX / TORX SCREW

Código del Inserto Le Code de Commande Ordering Code	a (M)	b	T	d	a°	Detalle Del Producto / Détails Du Produit / Product Detail	
4015-M3.5x11	M3.5X0.6	10.7	15	5.3	60	PARA SISTEMA-S / POUR SYSTEM S / FOR S-SYSTEM	TORNILLO TORX / VIS TORX / TORX SCREW
4015-M3.5x12	M3.5X0.6	12	15	5.3	60	PARA SISTEMA-S / POUR SYSTEM S / FOR S-SYSTEM	TORNILLO TORX / VIS TORX / TORX SCREW
4015-M3.5x14	M3.5X0.6	13.7	15	5.3	60	PARA SISTEMA-S / POUR SYSTEM S / FOR S-SYSTEM	TORNILLO TORX / VIS TORX / TORX SCREW
1015-M4x8	M4X0.7	8	15	6.8	R	PARA SISTEMA-S / POUR SYSTEM S / FOR S-SYSTEM	TORNILLO TORX / VIS TORX / TORX SCREW
1015-M4x9	M4X0.7	9	15	6.8	R	PARA SISTEMA-S / POUR SYSTEM S / FOR S-SYSTEM	TORNILLO TORX / VIS TORX / TORX SCREW
1515-M4x9	M4X0.7	9	15	5.7	50	PARA SISTEMA-S / POUR SYSTEM S / FOR S-SYSTEM	TORNILLO TORX / VIS TORX / TORX SCREW
1015-M4x11	M4X0.7	10.8	15	6.8	R	PARA SISTEMA-S / POUR SYSTEM S / FOR S-SYSTEM	TORNILLO TORX / VIS TORX / TORX SCREW
1115-M4x10	M4X0.7	10	15	5.9	R	PARA SISTEMA-S / POUR SYSTEM S / FOR S-SYSTEM	TORNILLO TORX / VIS TORX / TORX SCREW
1315-M4x11	M4X0.7	11.1	15	5	45	PARA SISTEMA-S / POUR SYSTEM S / FOR S-SYSTEM	TORNILLO TORX / VIS TORX / TORX SCREW
1415-M4x11	M4X0.7	11	15	5.6	50	PARA SISTEMA-S / POUR SYSTEM S / FOR S-SYSTEM	TORNILLO TORX / VIS TORX / TORX SCREW
1515-M4x11	M4X0.7	11.1	15	5.6	50	PARA SISTEMA-S / POUR SYSTEM S / FOR S-SYSTEM	TORNILLO TORX / VIS TORX / TORX SCREW
1615-M4x11	M4X0.7	11.1	15	6	50	PARA SISTEMA-S / POUR SYSTEM S / FOR S-SYSTEM	TORNILLO TORX / VIS TORX / TORX SCREW
3015-M4x9	M4X0.7	9	15	5.6	50	PARA SISTEMA-S / POUR SYSTEM S / FOR S-SYSTEM	TORNILLO TORX / VIS TORX / TORX SCREW
3015-M4x11	M4X0.7	11	15	5.6	50	PARA SISTEMA-S / POUR SYSTEM S / FOR S-SYSTEM	TORNILLO TORX / VIS TORX / TORX SCREW
4015-M4X8	M4X0.7	8	15	5.6	50	PARA SISTEMA-S / POUR SYSTEM S / FOR S-SYSTEM	TORNILLO TORX / VIS TORX / TORX SCREW
4015-M4x9	M4X0.7	9	15	5.6	50	PARA SISTEMA-S / POUR SYSTEM S / FOR S-SYSTEM	TORNILLO TORX / VIS TORX / TORX SCREW
4015-M4x10	M4X0.7	10	15	5.6	50	PARA SISTEMA-S / POUR SYSTEM S / FOR S-SYSTEM	TORNILLO TORX / VIS TORX / TORX SCREW
4015-M4x11	M4X0.7	11	15	5.6	50	PARA SISTEMA-S / POUR SYSTEM S / FOR S-SYSTEM	TORNILLO TORX / VIS TORX / TORX SCREW
4015-M4x12	M4X0.7	12	15	5.7	50	PARA SISTEMA-S / POUR SYSTEM S / FOR S-SYSTEM	TORNILLO TORX / VIS TORX / TORX SCREW
4115-M4x12	M4X0.7	12	15	5.6	55	PARA SISTEMA-S / POUR SYSTEM S / FOR S-SYSTEM	TORNILLO TORX / VIS TORX / TORX SCREW
4515-M4x8	M4X0.7	8	15	5.1	50	PARA SISTEMA-S / POUR SYSTEM S / FOR S-SYSTEM	TORNILLO TORX / VIS TORX / TORX SCREW
4515-M4x11	M4X0.7	11	15	5.1	50	PARA SISTEMA-S / POUR SYSTEM S / FOR S-SYSTEM	TORNILLO TORX / VIS TORX / TORX SCREW
4615-M4x11	M4X0.7	11	15	6	50	PARA SISTEMA-S / POUR SYSTEM S / FOR S-SYSTEM	TORNILLO TORX / VIS TORX / TORX SCREW
1015-M4.5x12	M4.5X0.75	12	15	6.6	50	PARA SISTEMA-S / POUR SYSTEM S / FOR S-SYSTEM	TORNILLO TORX / VIS TORX / TORX SCREW
1020-M4.5x14	M4.5X0.75	14	20	6.5	45	PARA SISTEMA-S / POUR SYSTEM S / FOR S-SYSTEM	TORNILLO TORX / VIS TORX / TORX SCREW
1020-M4.5x16	M4.5X0.75	16	20	6.5	45	PARA SISTEMA-S / POUR SYSTEM S / FOR S-SYSTEM	TORNILLO TORX / VIS TORX / TORX SCREW
1120-M4.5x12	M4.5X0.75	12.1	20	7.9	R	PARA SISTEMA-S / POUR SYSTEM S / FOR S-SYSTEM	TORNILLO TORX / VIS TORX / TORX SCREW
1515-M4.5x11	M4.5X0.75	11	15	6.4	45	PARA SISTEMA-S / POUR SYSTEM S / FOR S-SYSTEM	TORNILLO TORX / VIS TORX / TORX SCREW
4015-M4.5x11	M4.5X0.75	11	15	6.4	45	PARA SISTEMA-S / POUR SYSTEM S / FOR S-SYSTEM	TORNILLO TORX / VIS TORX / TORX SCREW
4020-M4.5x10	M4.5X0.75	10	20	6.5	55	PARA SISTEMA-S / POUR SYSTEM S / FOR S-SYSTEM	TORNILLO TORX / VIS TORX / TORX SCREW
4020-M4.5x12	M4.5X0.75	12	20	6.5	55	PARA SISTEMA-S / POUR SYSTEM S / FOR S-SYSTEM	TORNILLO TORX / VIS TORX / TORX SCREW
1020-M5x7.5	M5X0.8	7.5	20	6.5	50	PARA SISTEMA-S / POUR SYSTEM S / FOR S-SYSTEM	TORNILLO TORX / VIS TORX / TORX SCREW
1020-M5x11	M5X0.8	11	20	6.6	50	PARA SISTEMA-S / POUR SYSTEM S / FOR S-SYSTEM	TORNILLO TORX / VIS TORX / TORX SCREW
1020-M5x14	M5X0.8	14.1	20	6.8	50	PARA SISTEMA-S / POUR SYSTEM S / FOR S-SYSTEM	TORNILLO TORX / VIS TORX / TORX SCREW
1120-M5x13	M5X0.8	13	20	7	R	PARA SISTEMA-S / POUR SYSTEM S / FOR S-SYSTEM	TORNILLO TORX / VIS TORX / TORX SCREW
1615-M5x14	M5X0.8	14	15	7.3	50	PARA SISTEMA-S / POUR SYSTEM S / FOR S-SYSTEM	TORNILLO TORX / VIS TORX / TORX SCREW
1620-M5x18	M5X0.8	18	20	8.15	50	PARA SISTEMA-S / POUR SYSTEM S / FOR S-SYSTEM	TORNILLO TORX / VIS TORX / TORX SCREW
1620-M5x22	M5X0.8	22	20	8.15	50	PARA SISTEMA-S / POUR SYSTEM S / FOR S-SYSTEM	TORNILLO TORX / VIS TORX / TORX SCREW
4420-M5x14	M5X0.8	14	20	6.6	60	PARA SISTEMA-S / POUR SYSTEM S / FOR S-SYSTEM	TORNILLO TORX / VIS TORX / TORX SCREW
1020-M6x16	M6X1.0	16	20	8.5	50	PARA SISTEMA-S / POUR SYSTEM S / FOR S-SYSTEM	TORNILLO TORX / VIS TORX / TORX SCREW
1420-M6x16	M6X1.0	16	20	7.6	50	PARA SISTEMA-S / POUR SYSTEM S / FOR S-SYSTEM	TORNILLO TORX / VIS TORX / TORX SCREW
1520-M6x16	M6X1.0	16	20	8.2	50	PARA SISTEMA-S / POUR SYSTEM S / FOR S-SYSTEM	TORNILLO TORX / VIS TORX / TORX SCREW
1710-U5-40x12.2	UNC 5-40	12.2	10	5.6	60	PARA SISTEMA-S / POUR SYSTEM S / FOR S-SYSTEM	TORNILLO TORX / VIS TORX / TORX SCREW
1720-U8-32x10	UNC 8-32	10	20	7.5	60	PARA SISTEMA-S / POUR SYSTEM S / FOR S-SYSTEM	TORNILLO TORX / VIS TORX / TORX SCREW
1720-U8-32x15	UNC 8-32	15	20	7.5	60	PARA SISTEMA-S / POUR SYSTEM S / FOR S-SYSTEM	TORNILLO TORX / VIS TORX / TORX SCREW
1707-U4-48x6	UNF 4-48	6	7	3.27	60	PARA SISTEMA-S / POUR SYSTEM S / FOR S-SYSTEM	TORNILLO TORX / VIS TORX / TORX SCREW
1707-U4-48x6.5	UNF 4-48	6.5	7	3.27	60	PARA SISTEMA-S / POUR SYSTEM S / FOR S-SYSTEM	TORNILLO TORX / VIS TORX / TORX SCREW
1707-U4-48x8.2	UNF 4-48	8.2	7	3.27	60	PARA SISTEMA-S / POUR SYSTEM S / FOR S-SYSTEM	TORNILLO TORX / VIS TORX / TORX SCREW

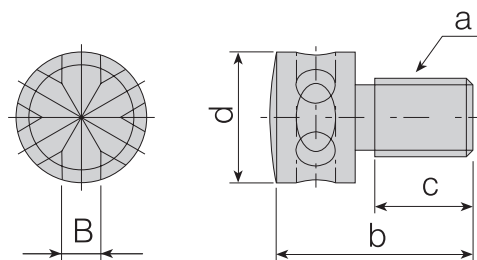

Código del Inserto Le Code de Commande Ordering Code	AXIAL-EINSTELLSCHRAUBE / VITI DI REGOLAZIONE ASSIALE / AXIAL ADJUST SCREWS					Detalle Del Producto / Détails Du Produit / Product Detail
	a (M)	b	c	d	B	
2600-M4x9.5	M4x0.5	5.5	4	4	1.5	Para Cartucho / Pour Cartouche / For Cartridge Axial Adj. Tornillo / Vis de Réglage Axial / Axial Adjust Screw
2600-M5x13	M5x0.5	12.8	7	8.7	2.5	Para Cartucho / Pour Cartouche / For Cartridge Axial Adj. Tornillo / Vis de Réglage Axial / Axial Adjust Screw
2600-M6x18	M6x1.0	18.2	9	10	3.5	Para Cartucho / Pour Cartouche / For Cartridge Axial Adj. Tornillo / Vis de Réglage Axial / Axial Adjust Screw

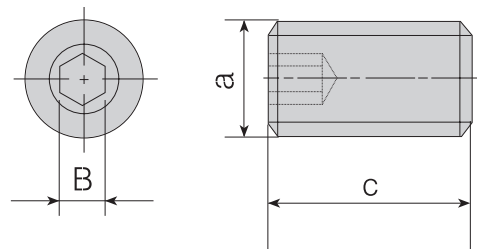

Código del Inserto Le Code de Commande Ordering Code	TORNILLOS DE AJUSTE RADIAL / RADIAUX RÉGLABLES VISS / RADIAL ADJUST SCREWS			Detalle Del Producto / Détails Du Produit / Product Detail
	a (M)	c	B	
2715-M3x4	M3x0.5	4	1.5	CABEZAS ASPERAS DE MANDRINAR POUR TÊTES D'ALEPAGE / FOR ROUGH BORING HEADS CATUCHOS PARA CABEZAS ASPERAS DE MANDRINAR POUR CHEFS ASEPTISÉE BRUTE CARTOUCHE / FOR ROUGH BORING HEADS CARTRIDGE
2715-M3x5	M3x0.5	5	1.5	CABEZAS ASPERAS DE MANDRINAR POUR TÊTES D'ALEPAGE / FOR ROUGH BORING HEADS CATUCHOS PARA CABEZAS ASPERAS DE MANDRINAR POUR CHEFS ASEPTISÉE BRUTE CARTOUCHE / FOR ROUGH BORING HEADS CARTRIDGE
2715-M3x8	M3x0.5	8	1.5	CABEZAS ASPERAS DE MANDRINAR POUR TÊTES D'ALEPAGE / FOR ROUGH BORING HEADS CATUCHOS PARA CABEZAS ASPERAS DE MANDRINAR POUR CHEFS ASEPTISÉE BRUTE CARTOUCHE / FOR ROUGH BORING HEADS CARTRIDGE
2702-M4x4	M4x0.7	4	2	PARA CARTUCHO / POUR CARTOUCHE / FOR CARTRIDGE PARA CARTUCHO / POUR CARTOUCHE / FOR CARTRIDGE
2702-M4x10	M4x0.7	10	2	PARA CARTUCHO / POUR CARTOUCHE / FOR CARTRIDGE PARA CARTUCHO / POUR CARTOUCHE / FOR CARTRIDGE
2702-M4x12	M4x0.7	12	2	CABEZAS ASPERAS DE MANDRINAR POUR TÊTES D'ALEPAGE / FOR ROUGH BORING HEADS CATUCHOS PARA CABEZAS ASPERAS DE MANDRINAR POUR CHEFS ASEPTISÉE BRUTE CARTOUCHE / FOR ROUGH BORING HEADS CARTRIDGE
2725-M5x6	M5x0.8	5	2.5	PARA CARTUCHO / POUR CARTOUCHE / FOR CARTRIDGE PARA CARTUCHO / POUR CARTOUCHE / FOR CARTRIDGE
2725-M5x10	M5x0.8	10	2.5	PARA CARTUCHO / POUR CARTOUCHE / FOR CARTRIDGE PARA CARTUCHO / POUR CARTOUCHE / FOR CARTRIDGE
2725-M5x12	M5x0.8	12	2.5	CABEZAS ASPERAS DE MANDRINAR POUR TÊTES D'ALEPAGE / FOR ROUGH BORING HEADS CATUCHOS PARA CABEZAS ASPERAS DE MANDRINAR POUR CHEFS ASEPTISÉE BRUTE CARTOUCHE / FOR ROUGH BORING HEADS CARTRIDGE
2725-M5x14	M5x0.8	14	2.5	CABEZAS ASPERAS DE MANDRINAR POUR TÊTES D'ALEPAGE / FOR ROUGH BORING HEADS CATUCHOS PARA CABEZAS ASPERAS DE MANDRINAR POUR CHEFS ASEPTISÉE BRUTE CARTOUCHE / FOR ROUGH BORING HEADS CARTRIDGE
2703-M6x16	M6x1	16	3	CABEZAS ASPERAS DE MANDRINAR POUR TÊTES D'ALEPAGE / FOR ROUGH BORING HEADS CATUCHOS PARA CABEZAS ASPERAS DE MANDRINAR POUR CHEFS ASEPTISÉE BRUTE CARTOUCHE / FOR ROUGH BORING HEADS CARTRIDGE
2704-M8x25	M8x1.25	25.9	4	CABEZAS ASPERAS DE MANDRINAR POUR TÊTES D'ALEPAGE / FOR ROUGH BORING HEADS CATUCHOS PARA CABEZAS ASPERAS DE MANDRINAR POUR CHEFS ASEPTISÉE BRUTE CARTOUCHE / FOR ROUGH BORING HEADS CARTRIDGE
2704-M8x1x5	M8x1	5	4	CON AGUJERO DE REFRIGERANTE POUR TROU DE LIQUIDE DE REFROIDISSEMENT / FOR COOLANT HOLE PARA HERRAMIENTAS JET / POUR OUTILS JET / FOR JET TOOLS
2705-G1/8x5.5	G1/8	5.5	5	CON AGUJERO DE REFRIGERANTE POUR TROU DE LIQUIDE DE REFROIDISSEMENT / FOR COOLANT HOLE PARA HERRAMIENTAS JET / POUR OUTILS JET / FOR JET TOOLS

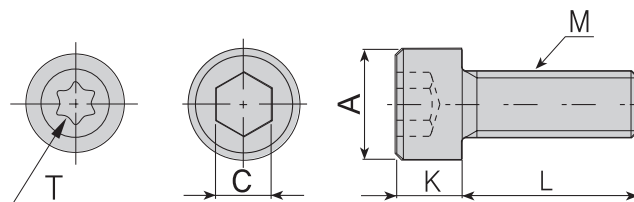

Código del Inserto
Le Code de Commande
Ordering Code

TORNILLOS INBUS / INBUS VISS / INBUS SCREWS

	M	A	C	K	L	Detalle Del Producto / Détails Du Produit / Product Detail	
2503-M4x10	M4x0.7	6.85	3	4	10	ALGUNOS TORNILLOS DE HERRAMIENTAS DE RANURADO / VIS D'OUTILS DE RAINURAGE	GROOVING TOOLS SCREW
2525-M3X14	M3X0.5	5.4	2.5	2.9	14	PARA TORNILLOS DECARTUCHO CABEZAS DE MANDRINAR / POUR POUR TETES D'ALESAGE VIS	SCREW FOR BORING HEAD CARTRIDGE
2503-M4X20	M4x0.7	7	3	3.9	20	PARA TORNILLOS DECARTUCHO CABEZAS DE MANDRINAR / POUR POUR TETES D'ALESAGE VIS	SCREW FOR BORING HEAD CARTRIDGE
2503-M4X12	M4x0.7	6.85	3	4	12	ALGUNOS TORNILLOS DE HERRAMIENTAS DE RANURADO / VIS D'OUTILS DE RAINURAGE	GROOVING TOOLS SCREW
2503-M4X15	M4x0.7	6.85	3	4	15	PARA TORNILLOS DECARTUCHO CABEZAS DE MANDRINAR / POUR POUR TETES D'ALESAGE VIS	SCREW FOR BORING HEAD CARTRIDGE
2504-M5X16	M5X0.8	8.5	4	5	16	ALGUNOS TORNILLOS DE HERRAMIENTAS DE RANURADO / VIS D'OUTILS DE RAINURAGE	GROOVING TOOLS SCREW
2504-M5X12	M5X0.8	8.5	4	5	12	ALGUNOS TORNILLOS DE HERRAMIENTAS DE RANURADO / VIS D'OUTILS DE RAINURAGE	GROOVING TOOLS SCREW
2504-M5X25	M5X0.8	8.5	4	5	25	PARA TORNILLOS DECARTUCHO CABEZAS DE MANDRINAR / POUR POUR TETES D'ALESAGE VIS	SCREW FOR BORING HEAD CARTRIDGE
2505-M6X16	M6X1	9.9	5	6	16	ALGUNOS TORNILLOS DE HERRAMIENTAS DE RANURADO / VIS D'OUTILS DE RAINURAGE	GROOVING TOOLS SCREW
2505-M6X20	M6X1	9.9	5	6	20	ALGUNOS TORNILLOS DE HERRAMIENTAS DE RANURADO / VIS D'OUTILS DE RAINURAGE	GROOVING TOOLS SCREW
2505-M6X25	M6X1	9.9	5	6	25	PARA TORNILLO DE ABRAZADERA / POUR LE VIS A BRIDE DU BLOC	BLOCK CLAMP SCREW
2505-M6X30	M6X1	9.9	5	6	30	PARA TORNILLOS DECARTUCHO CABEZAS DE MANDRINAR / POUR POUR TETES D'ALESAGE VIS	SCREW FOR BORING HEAD CARTRIDGE
2306-M8X37	M8X1.25	13	6	6.4	31.5	TORNILLO DE MONTAJE (CABEZA PEQUEÑA) / VIS DE MONTAGE (PETITE TÊTE)	MOUNTING SCREW (SMALL HEAD)
2405-M8X30	M8X1.25	13	5	5	30	A16 TORNILLO DE MONTAJE (CABEZA PEQUEÑA) / VIS DE MONTAGE (PETITE TÊTE)	MOUNTING SCREW (SMALL HEAD)
2506-M8X20	M8X1.25	13	6	7.9	20	TORNILLO DE MONTAJE DEL CARTUCHO / CARTOUCHE DE MONTAGE VIS	CARTRIDGE MOUNTING SCREW
2506-M8X30	M8X1.25	13	6	7.9	30	A16 TORNILLO DE FIJACIÓN / VIS DE FIXATION	MOUNTING SCREW
2506-M8X35	M8X1.25	13	6	7.9	35	PARA TORNILLOS DECARTUCHO CABEZAS DE MANDRINAR / POUR POUR TETES D'ALESAGE VIS	SCREW FOR BORING HEAD CARTRIDGE
2406-M8X30	M8X1.25	12	6	7.9	30	A16 TORNILLO DE FIJACIÓN / VIS DE FIXATION	MOUNTING SCREW
2407-M10X30	M10X1.5	16	7	6	30	A16 TORNILLO DE FIJACIÓN / VIS DE FIXATION	MOUNTING SCREW
2408-M10X30	M10X1.5	13	8	10	30	A22 TORNILLO DE FIJACIÓN / VIS DE FIXATION	MOUNTING SCREW
2508-M10X30	M10X1.5	16	8	10	30	A22 TORNILLO DE FIJACIÓN / VIS DE FIXATION	MOUNTING SCREW
2508-M10X40	M10X1.5	16	8	10	40	PARA TORNILLOS DECARTUCHO CABEZAS DE MANDRINAR / POUR POUR TETES D'ALESAGE VIS	SCREW FOR BORING HEAD CARTRIDGE
2408-M12X35	M12X1.75	18	8	7	35	A27 TORNILLO DE FIJACIÓN / VIS DE FIXATION	MOUNTING SCREW
2510-M12X35	M12X1.75	18	10	12	35	A27 TORNILLO DE FIJACIÓN / VIS DE FIXATION	MOUNTING SCREW
2514-M16X35	M16X2.0	23.7	14	16	35	A32 TORNILLO DE FIJACIÓN / VIS DE FIXATION	MOUNTING SCREW
AAV-11-U5-40x4.5	UNC 5-40	5.4	T10	2.8	4.5	16 ER/L, 16 IR/L TORNILLO DE ABRAZADERA / VIS D'ASSISE	SHIM SCREWS
AAV-12-U8-32x5.5	UNC 8-32	6.7	T20	3.8	5.5	22 ER/L, 22 IR/L TORNILLO DE ABRAZADERA / VIS D'ASSISE	SHIM SCREWS
AAV-15-M5x5.7	M5X0.8	8.5	T20	3.15	5.7	27 ER/L, 27 IR/L TORNILLO DE ABRAZADERA / VIS D'ASSISE	SHIM SCREWS

Imagen del Producto
Image du Produit
Product Picture

ANILLO / BAGUE / RING

Código / Code / Code

Detalle Del Producto / Détails Du Produit / Product Detail



ACS-01	PARA SISTEMA-C / POUR SYSTEM C / FOR C SYSTEM	TNGN, CNGN, DNGN, SNGN ANILLO / BAGUE / RING
AS-01	PARA SISTEMA-T-M / POUR SYSTEM T-M / FOR T-M SYSTEM	AKV-30-M6x22 ANILLO / BAGUE / RING
AS-02	PARA SISTEMA-T / POUR SYSTEM T / FOR T SYSTEM	AKV-19-M7x25 ANILLO / BAGUE / RING

O-RING / ANNEAU EN O / ORING

Imagen del Producto Image du Produit Product Picture	Código / Code / Code	Detalle Del Producto / Détails Du Produit / Product Detail	
	AOR-01	PARA SISTEMA-P / POUR SYSTEM P / FOR P SYSTEM	O-RING / ANNEAU EN O / ORING
	AXR-01	PARA SISTEMA-T-P / POUR T SYSTEM-P / FOR T-P SYSTEM	O-RING / ANNEAU EN O / ORING

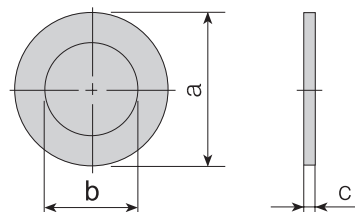
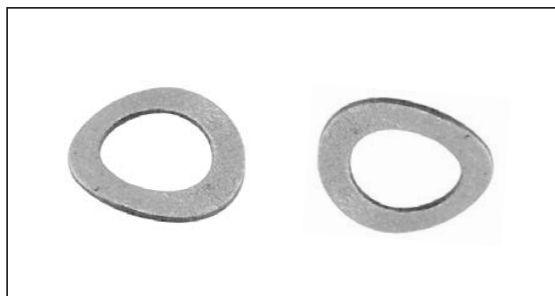

ARANDELA / TIMBRE / SCREW WASHER

Código del Inserto Le Code de Commande Ordering Code	a	b	c	Detalle Del Producto / Détails Du Produit / Product Detail	
ABPL-01	10.5	6.2	0.5	ARANDELA / TIMBRE / WASHER	Arandela / TIMBRE / WASHER
ABPL-02	12.75	7.1	0.45	ARANDELA / TIMBRE / WASHER	Arandela / TIMBRE / WASHER
ABPL-03	5.3	3.2	0.5	ARANDELA / TIMBRE / WASHER	TER - TIR 16 ER/EL - IR/IL ANILLO DE TORNILLO / ASSIES VIS RING / SHIM SCREW WASHER
ABPL-04	6.9	4.2	0.5	ARANDELA / TIMBRE / WASHER	TER - TIR 22 ER/EL - IR/IL ANILLO DE TORNILLO / ASSIES VIS RING / SHIM SCREW WASHER
ABPL-05	8.5	5	0.5	ARANDELA / TIMBRE / WASHER	TER - TIR 27 ER/EL - IR/IL ANILLO DE TORNILLO / ASSIES VIS RING / SHIM SCREW WASHER

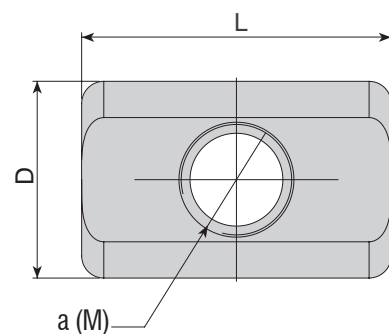

CARTUCHOS CABEZAS DE MANDRINAR / POUR TÊTES D'ALEPAGE / BORING HEADS WEDGE

Código del Inserto Le Code de Commande Ordering Code	a (M)	D	L	Detalle Del Producto / Détails Du Produit / Product Detail	
ABKS-D16	M3x0.5	4.9	6	CABEZAS ASPERAS DE MANDRINAR / POUR TÊTES D'ALEPAGE / FOR ROUGH BORING HEADS	ABHR-D16x42-W16-L90
ABKS-D20	M4x0.7	5.9	9	CABEZAS ASPERAS DE MANDRINAR / POUR TÊTES D'ALEPAGE / FOR ROUGH BORING HEADS	ABHR-D20x50-W20-L100
ABKS-D25	M4x0.7	5.9	12	CABEZAS ASPERAS DE MANDRINAR / POUR TÊTES D'ALEPAGE / FOR ROUGH BORING HEADS	ABHR-D25x60-W20-L110
ABKS-D32	M5x0.8	8.9	14	CABEZAS ASPERAS DE MANDRINAR / POUR TÊTES D'ALEPAGE / FOR ROUGH BORING HEADS	ABHR-D32x64-W25-L120
ABKS-D40	M6x1	10.9	18	CABEZAS ASPERAS DE MANDRINAR / POUR TÊTES D'ALEPAGE / FOR ROUGH BORING HEADS	ABHR-D40x80-W32-L140
ABKS-D50	M8x1.25	13.9	28	CABEZAS ASPERAS DE MANDRINAR / POUR TÊTES D'ALEPAGE / FOR ROUGH BORING HEADS	ABHR-D50x100-W32-L160
ABKS-D63	M10x1.5	15.9	35	CABEZAS ASPERAS DE MANDRINAR / POUR TÊTES D'ALEPAGE / FOR ROUGH BORING HEADS	ABHR-D63x80-W32-L140, ABHR-D63x130-W40-L200
ABKS-D80	M12x1.75	17.9	45	CABEZAS ASPERAS DE MANDRINAR / POUR TÊTES D'ALEPAGE / FOR ROUGH BORING HEADS	ABHR-D80x140-W40-L210, ABHR-D80x140-W40-L210-B

BLOQUES PARA ABRAZAR Y ABRAZADERAS DE HOJAS DE RANURADO PROFUNDO / BLOCS DE SÉPARATION ET PROFOND RAINURER LAMES COLLIERS WEDGES FOR PARTING AND DEEP GROOVING BLADES BLOCKS			
Imagen del Producto Image du Produit Product Picture	Código / Code / Code	Detalle Del Producto / Détails Du Produit / Product Detail	
	ABK-01	PARA BLOQUEO DE CUCHILLAS / POUR LAME BLOC / FOR BLADE BLOCK	ALBU-20-26 ABRAZADERA / BRIDE / WEDGE
	ABK-02	PARA BLOQUEO DE CUCHILLAS / POUR LAME BLOC / FOR BLADE BLOCK	ALBU-25-26 ABRAZADERA / BRIDE / WEDGE
	ABK-03	PARA BLOQUEO DE CUCHILLAS / POUR LAME BLOC / FOR BLADE BLOCK	ALBU-20-32 ABRAZADERA / BRIDE / WEDGE
	ABK-04	PARA BLOQUEO DE CUCHILLAS / POUR LAME BLOC / FOR BLADE BLOCK	ALBU-25-32, ALBU-32-32 ABRAZADERA / BRIDE / WEDGE

LLAVE DE HOJA / CLÉ À LAME / BLADE WRENCH			
Imagen del Producto Image du Produit Product Picture	Código / Code / Code	Detalle Del Producto / Détails Du Produit / Product Detail	
	ALA-01	AKL LLAVE DE HOJA / CLÉ À LAME / FOR BLADE WRENCH	
	ALA-02	AKL LLAVE DE HOJA / CLÉ À LAME / FOR BLADE WRENCH	

LLAVES ALLEN / CLÉS ALLEN / ALLEN WRENCH			
Imagen del Producto Image du Produit Product Picture	Código / Code / Code	Detalle Del Producto / Détails Du Produit / Product Detail	
	AAL-01-2	2 mm	LLAVES ALLEN / CLÉS ALLEN / ALLEN WRENCH
	AAL-02-2.5	2.5 mm	LLAVES ALLEN / CLÉS ALLEN / ALLEN WRENCH
	AAL-03-3	3 mm	LLAVES ALLEN / CLÉS ALLEN / ALLEN WRENCH
	AAL-05-4	4 mm	LLAVES ALLEN / CLÉS ALLEN / ALLEN WRENCH
	AAL-07-5	5 mm	LLAVES ALLEN / CLÉS ALLEN / ALLEN WRENCH
	AAL-08-6	6 mm	LLAVES ALLEN / CLÉS ALLEN / ALLEN WRENCH
	AAL-09-1.5	1.5 mm	LLAVES ALLEN / CLÉS ALLEN / ALLEN WRENCH
	AAL-11-8	8 mm	LLAVES ALLEN / CLÉS ALLEN / ALLEN WRENCH
	AAL-12-10	10 mm	LLAVES ALLEN / CLÉS ALLEN / ALLEN WRENCH

LLAVES TORX / CLÉS TORX / TORX WRENCH			
Imagen del Producto Image du Produit Product Picture	Código / Code / Code	Detalle Del Producto / Détails Du Produit / Product Detail	
	80-T06	T06 TORX-SCHLÜSSEL / CLÉ TORX / TORX WRENCH	
	80-T07	T07 TORX-SCHLÜSSEL / CLÉ TORX / TORX KEYS	
	80-T08	T08 TORX-SCHLÜSSEL / CLÉ TORX / TORX KEYS	
	80-T10	T10 TORX-SCHLÜSSEL / CLÉ TORX / TORX KEYS	
	80-T15	T15 TORX-SCHLÜSSEL / CLÉ TORX / TORX KEYS	
	80-T20	T20 TORX-SCHLÜSSEL / CLÉ TORX / TORX KEYS	
	81-T15	T15 T-TYP-TORX-SCHLÜSSEL / CLÉ TORX TIPO T / T-TYPE TORX KEY	
	81-T20	T20 T-TYP-TORX-SCHLÜSSEL / CLÉ TORX TIPO T / T-TYPE TORX KEY	

CÓDIGO CODE / CODE	DESCRIPCIÓN / LA DESCRIPTION	DESCRIPTION	P.N.
A/PTFNR/L ..	Barras de Mandrillar / Barres D'alésage	Boring Bars	108
A/SCLCR/L ..	Barras de Mandrillar Set Ensemble de Barres D'alésage	Boring Bars Set	127
A/SDUCR/L ..	Barras de Mandrillar Set Ensemble de Barres D'alésage	Boring Bars Set	128
AAKT-IG-R/L ..	Portaherramientas de Ranurado Externo Frontal Porte Outil Face Rainurage Extérieur	Face External Grooving Tool Holders	179
AAKT-KG-R/L ..	Portaherramientas de Ranurado Externo Frontal Porte Outil Face Rainurage Extérieur	Face External Grooving Tool Holders	178
AAKT-K-R/L ..	Portaherramientas de Ranurado Externo Frontal Porte Outil Face Rainurage Extérieur	Face External Grooving Tool Holders	177
AAKT-ZCC2-R/L ..	Portaherramientas de Ranurado Externo Frontal Porte Outil Face Rainurage Extérieur	Face External Grooving Tool Holders	178
AAUT-T20-R/L	Portaherramientas de Ranurado con Relieves de Esquina Porte-outils Rainurage Coin	Corner Reliefs PORTE-OUTILS À GORGE	16
ABHR ..	Cartucho de Cabezas de Mandrillado Áspero Ajustable Cartouches Têtes D'alésage Réglables Bruts	Adjustable Rough Boring Heads Cartridges	237
ABHRS ..	Cuerpo de Cabezas Mandrilladores Ajustables Corps Réglables Têtes D'alésage Bruts	Adjustable Rough Boring Heads Body	238
ABT-B4..	Portaherramientas de Brochado Porte-outils Brochage	Broaching Tool holders	18
ACBM ..	Herramientas de Fresado Avellanado Outils de Fraisage à Fraiser	Counter Sink Milling Tools	245
ACM ..	Fresas de Chaflán Fraises en Bout de Chamfreinage	Chamfering End Mills	243
ACM45-SP..	Fresas de Chaflán Fraises en Bout de Chamfreinage	Chamfering End Mills	244
ACPBT-..	Herramientas de Biselado de Tuberías Tuyau Outils Biseautage	Pipe Beveling Tools	147
ADCR	Herramientas de Anillo de Chaflán de Taladro Outils de Forage Chanfreinage Anneau	Drill Chamfering Rings	228
ADKT-123-R/L ..	Portaherramientas de Ranurado Externo Porte-Outils à Rainurer	External Grooving Tool Holders	165
ADKT-151.22-R/L ..	Portaherramientas de Ranurado Externo Porte-Outils à Rainurer	External Grooving Tool Holders	166
ADKT-151.23-R/L ..	Portaherramientas de Ranurado Externo Porte-Outils à Rainurer	External Grooving Tool Holders	166
ADKT-154.91-R/L ..	Portaherramientas de Ranurado Externo Porte-Outils à Rainurer	External Grooving Tool Holders	167
ADKT-ARN-R/L ..	Portaherramientas de Ranurado Externo Porte-Outils à Rainurer	External Grooving Tool Holders	167
ADKT-CD-R/L ..	Portaherramientas de Ranurado Externo Porte-Outils à Rainurer	External Grooving Tool Holders	172
ADKT-GP-R/L ..	Portaherramientas de Ranurado Externo Porte-Outils à Rainurer	External Grooving Tool Holders	171
ADKT-H22-R/L ..	Portaherramientas de Ranurado Externo Porte-Outils à Rainurer	External Grooving Tool Holders	170
ADKT-HK-R/L ..	Portaherramientas de Ranurado Externo Porte-Outils à Rainurer	External Grooving Tool Holders	161
ADKT-H-R/L ..	Portaherramientas de Ranurado Externo Porte-Outils à Rainurer	External Grooving Tool Holders	160
ADKT-HS223- R/L ..	Portaherramientas de Ranurado Externo Porte-Outils à Rainurer	External Grooving Tool Holders	161
ADKT-IDC-R/L ..	Portaherramientas de Ranurado Externo Porte-Outils à Rainurer	External Grooving Tool Holders	164
ADKT-IGI-R/L ..	Portaherramientas de Ranurado Externo Porte-Outils à Rainurer	External Grooving Tool Holders	164
ADKT-IG-R/L ..	Portaherramientas de Ranurado Externo Porte-Outils à Rainurer	External Grooving Tool Holders	164
ADKT-IGTN-R/L ..	Portaherramientas de Ranurado Externo Porte-Outils à Rainurer	External Grooving Tool Holders	164

CÓDIGO CODE / CODE	DESCRIPCIÓN / LA DESCRIPTION	DESCRIPTION	P.N.
ADKT-I-R/L ..	Portaherramientas de Ranurado Externo Porte-Outils à Rainurer	External Grooving Tool Holders	164
ADKT-I-R/L ..-S	Portaherramientas de Ranurado Externo (Tipo Suizo) Rainurage Extérieur (Type Suisse) Les Porte-outils	External Grooving Tool Holders (Swiss Type)	174
ADKT-ITG-R/L ..	Portaherramientas de Ranurado Externo Porte-Outils à Rainurer	External Grooving Tool Holders	163
ADKT-KG-R/L ..	Portaherramientas de Ranurado Externo Porte-Outils à Rainurer	External Grooving Tool Holders	159
ADKT-KG-R/L ..-S	Portaherramientas de Ranurado Externo (Tipo Suizo) Rainurage Extérieur (Type Suisse) Les Porte-outils	External Grooving Tool Holders (Swiss Type)	175
ADKT-KM-R/L ..	Portaherramientas de Ranurado Externo Porte-Outils à Rainurer	External Grooving Tool Holders	163
ADKT-K-R/L ..	Portaherramientas de Ranurado Externo Porte-Outils à Rainurer	External Grooving Tool Holders	158
ADKT-K-R/L .. -H	Portaherramientas de Ranurado Externo con Herramientas de Refrigerante Porte-outils de Rainurage Extérieurs Avec Trou D'arrosage	External Grooving Tool Holders With Coolant Tools	185
ADKT-K-R/L ..-S	Portaherramientas de Ranurado Externo (Tipo Suizo) Rainurage Extérieur (Type Suisse) Les Porte-outils	External Grooving Tool Holders (Swiss Type)	175
ADKT-LGC-R/L ..	Portaherramientas de Ranurado Externo Porte-Outils à Rainurer	External Grooving Tool Holders	169
ADKT-RD-R/L ..	Portaherramientas de Ranurado Externo Porte-Outils à Rainurer	External Grooving Tool Holders	169
ADKT-RD-R/L .. -S	Portaherramientas de Ranurado Externo (Tipo Suizo) Rainurage Extérieur (Type Suisse) Les Porte-outils	External Grooving Tool Holders (Swiss Type)	173
ADKT-SGC-R/L ..	Portaherramientas de Ranurado Externo Porte-Outils à Rainurer	External Grooving Tool Holders	160
ADKT-SWC-R/L ..	Portaherramientas de Ranurado Externo Porte-Outils à Rainurer	External Grooving Tool Holders	172
ADKT-T12P-R/L	Herramientas de Ranurado Poly-V Porte-outils Poly-V de Rainurage	Poly-V Grooving Tool Holders	12
ADKT-TD-R/L ..	Portaherramientas de Ranurado Externo Porte-Outils à Rainurer	External Grooving Tool Holders	168
ADKT-TD-R/L ..-S	Portaherramientas de Ranurado Externo (Tipo Suizo) Rainurage Extérieur (Type Suisse) Les Porte-outils	External Grooving Tool Holders (Swiss Type)	173
ADKT-TD-R/L..-H	Portaherramientas de Ranurado Externo con Herramientas de Refrigerante Porte-outils de Rainurage Extérieurs Avec Trou D'arrosage	External Grooving Tool Holders With Coolant Tools	185
ADKT-TG-R/L ..	Portaherramientas de Ranurado Externo Porte-Outils à Rainurer	External Grooving Tool Holders	170
ADKT-TG-R/L .. -S	Portaherramientas de Ranurado Externo (Tipo Suizo) Rainurage Extérieur (Type Suisse) Les Porte-outils	External Grooving Tool Holders (Swiss Type)	176
ADKT-WGX...R/L ..	Portaherramientas de Ranurado Externo Porte-Outils à Rainurer	External Grooving Tool Holders	171
ADKT-WGX...R/L ..-S	Portaherramientas de Ranurado Externo (Tipo Suizo) Rainurage Extérieur (Type Suisse) Les Porte-outils	External Grooving Tool Holders (Swiss Type)	176
ADKT-ZCC1-R/L ..	Portaherramientas de Ranurado Externo Porte-Outils à Rainurer	External Grooving Tool Holders	161
ADKT-ZCC2-R/L ..	Portaherramientas de Ranurado Externo Porte-Outils à Rainurer	External Grooving Tool Holders	162
ADKT-ZCC2-R/L ..-S	Portaherramientas de Ranurado Externo (Tipo Suizo) Rainurage Extérieur (Type Suisse) Les Porte-outils	External Grooving Tool Holders (Swiss Type)	174
AEKR/L ..	Herramientas de Corte Económico Outils de Coupe Économique	Economic Cutting Tools	234
AEM90-3P..	Molinos de Extremo / Fraises en Bout	End Mills	270
AEM90-3P..	Fresas Modulares / End Mills Modulaires	Modular End Mills	291
AEM90-4N..	Molinos de Extremo / Fraises en Bout	End Mills	271
AEM90-AD..	Molinos de Extremo / Fraises en Bout	End Mills	246-247- 248
AEM90-AD..	Fresas Modulares / End Mills Modulaires	Modular End Mills	286

CÓDIGO CODE / CODE	DESCRIPCIÓN / LA DESCRIPTION	DESCRIPTION	P.N.	CÓDIGO CODE / CODE	DESCRIPCIÓN / LA DESCRIPTION	DESCRIPTION	P.N.
AEM90-AN..	Molinos de Extremo / Fraises en Bout	End Mills	248-249	AFM42C-XD..	Fresado Frontal / Surfaçage	Face Milling	312
AEM90-AO..	Molinos de Extremo / Fraises en Bout	End Mills	255	AFM43(C)-OD..	Fresado Frontal / Surfaçage	Face Milling	312-313
AEM90-AO..	Fresas Modulares / End Mills Modulaires	Modular End Mills	285	AFM43(C)-OF..	Fresado Frontal / Surfaçage	Face Milling	313-351
AEM90-AP..	Molinos de Extremo / Fraises en Bout	End Mills	250-251- 252-253- 254-255	AFM43-ON..	Fresado Frontal / Surfaçage	Face Milling	314
AEM90-AP..	Fresas Modulares / End Mills Modulaires	Modular End Mills	287	AFM44-ON..	Fresado Frontal / Surfaçage	Face Milling	314
AEM90-AX..	Molinos de Extremo / Fraises en Bout	End Mills	256-257	AFM45(L)-HN..	Fresado Frontal / Surfaçage	Face Milling	315
AEM90-AX..	Fresas Modulares / End Mills Modulaires	Modular End Mills	286	AFM45(L)-SE..	Fresado Frontal / Surfaçage	Face Milling	316-317
AEM90-AZ..	Molinos de Extremo / Fraises en Bout	End Mills	258	AFM45(S)-SE	Fresado Frontal / Surfaçage	Face Milling	316
AEM90-BD..	Molinos de Extremo / Fraises en Bout	End Mills	259	AFM45C(L)-HN..	Fresado Frontal / Surfaçage	Face Milling	351
AEM90-BD.. -H	Extremo Modular (Herramientas de Tornillo) Modulaire Fin Mills (Outils de Type a Vis)	Modular End Mills (Screw Type Tools)	288	AFM45C(L)-SN..	Fresado Frontal / Surfaçage	Face Milling	317-318- 319
AEM90-DC..	Fresas Modulares / End Mills Modulaires	Modular End Mills	288	AFM45C-ON..	Fresado Frontal / Surfaçage	Face Milling	320
AEM90-ED..	Molinos de Extremo / Fraises en Bout	End Mills	260	AFM45C-XN..	Fresado Frontal / Surfaçage	Face Milling	352
AEM90-LN..	Molinos de Extremo / Fraises en Bout	End Mills	260-261- 262	AFM45-NN..	Fresado Frontal / Surfaçage	Face Milling	315
AEM90-R390..	Molinos de Extremo / Fraises en Bout	End Mills	262	AFM45-ON..	Fresado Frontal / Surfaçage	Face Milling	319
AEM90-R390..	Fresas Modulares / End Mills Modulaires	Modular End Mills	289	AFM45-SA..	Fresado Frontal / Surfaçage	Face Milling	318
AEM90-RT..	Molinos de Extremo / Fraises en Bout	End Mills	263	AFM45-XN..	Fresado Frontal / Surfaçage	Face Milling	320
AEM90-RT..	Fresas Modulares / End Mills Modulaires	Modular End Mills	289	AFM66-PN..	Fresado Frontal / Surfaçage	Face Milling	321
AEM90-SE..	Molinos de Extremo / Fraises en Bout	End Mills	264	AFM67-PN..	Fresado Frontal / Surfaçage	Face Milling	321
AEM90-SO..	Molinos de Extremo / Fraises en Bout	End Mills	264	AFM75-AP..	Fresado Frontal / Surfaçage	Face Milling	322
AEM90-SPGT..	Molinos de Extremo / Fraises en Bout	End Mills	265	AFM75C-SP..	Fresado Frontal / Surfaçage	Face Milling	352
AEM90-TNG..	Molinos de Extremo / Fraises en Bout	End Mills	265	AFM75-XO..	Fresado Frontal / Surfaçage	Face Milling	322
AEM90-TNG.. -H	Extremo Modular (Herramientas de Tornillo) Modulaire Fin Mills (Outils de Type a Vis)	Modular End Mills (Screw Type Tools)	290	AFM88C-SN..	Fresado Frontal / Surfaçage	Face Milling	323-324- 325-353
AEM90-VC2205.. -H	Molinos de Extremo / Fraises en Bout	End Mills	266	AFM88-SN..	Fresado Frontal / Surfaçage	Face Milling	323
AEM90-WN..	Molinos de Extremo / Fraises en Bout	End Mills	267	AFM89-SN..	Fresado Frontal / Surfaçage	Face Milling	325
AEM90-WN..	Fresas Modulares / End Mills Modulaires	Modular End Mills	290	AFM90(L)-LN..	Fresado Frontal / Surfaçage	Face Milling	332-333- 334-335- 336
AEM90-WNG.. -H	Molinos de Extremo / Fraises en Bout	End Mills	266	AFM90(S)-SD..	Fresado Frontal / Surfaçage	Face Milling	339
AEM90-XC..	Molinos de Extremo / Fraises en Bout	End Mills	268	AFM90-3P..	Fresado Frontal / Surfaçage	Face Milling	346
AEM90-XD..	Molinos de Extremo / Fraises en Bout	End Mills	267	AFM90-490..	Fresado Frontal / Surfaçage	Face Milling	338
AEM90-XN..	Molinos de Extremo / Fraises en Bout	End Mills	269	AFM90-4N..	Fresado Frontal / Surfaçage	Face Milling	346
AEM90-XO..	Molinos de Extremo / Fraises en Bout	End Mills	268	AFM90-AD..	Fresado Frontal / Surfaçage	Face Milling	326-327
AEM90-ZC..	Molinos de Extremo / Fraises en Bout	End Mills	269	AFM90-AN..	Fresado Frontal / Surfaçage	Face Milling	327-328- 329
AEM90-ZP..	Molinos de Extremo / Fraises en Bout	End Mills	270	AFM90-AO..	Fresado Frontal / Surfaçage	Face Milling	329
AEM95(C)-XD..	Fresas Modulares / End Mills Modulaires	Modular End Mills	291	AFM90-AP..	Fresado Frontal / Surfaçage	Face Milling	330-331
AEMR(C)-RD..	Fresas Frontales y de Copia Visage et Copie End Mills	Face and Copy End Mills	273	AFM90-AX..	Fresado Frontal / Surfaçage	Face Milling	331
AEMR-QP..	Fresas Frontales y de Copia Visage et Copie End Mills	Face and Copy End Mills	274	AFM90-BD..	Fresado Frontal / Surfaçage	Face Milling	332
AEMR-QP..	Fresas Modulares / End Mills Modulaires	Modular End Mills	295	AFM90C-TP..	Fresado Frontal / Surfaçage	Face Milling	353
AEMR-RC..	Fresas Modulares / End Mills Modulaires	Modular End Mills	292	AFM90-LO..	Fresado Frontal / Surfaçage	Face Milling	335-336
AEMR-RD..	Fresas Frontales y de Copia Visage et Copie End Mills	Face and Copy End Mills	273	AFM90-R290..	Fresado Frontal / Surfaçage	Face Milling	337
AEMR-RD..	Fresas Modulares / End Mills Modulaires	Modular End Mills	294	AFM90-R390..	Fresado Frontal / Surfaçage	Face Milling	337
AEMR-RP..	Fresas Frontales y de Copia Visage et Copie End Mills	Face and Copy End Mills	271-272	AFM90-RT..	Fresado Frontal / Surfaçage	Face Milling	338
AEMR-RP..	Fresas Modulares / End Mills Modulaires	Modular End Mills	292-293	AFM90-SE..	Fresado Frontal / Surfaçage	Face Milling	340
AEMR-RY..	Fresas Frontales y de Copia Visage et Copie End Mills	Face and Copy End Mills	272	AFM90-SP..	Fresado Frontal / Surfaçage	Face Milling	341
AEMR-RY..	Fresas Modulares / End Mills Modulaires	Modular End Mills	293	AFM90-TN..	Fresado Frontal / Surfaçage	Face Milling	342
AET	Adaptador Excéntrico de Para Taladro en U Adaptateur Excentrique Pour les forets U-Drill	Eccentric Adaptor For U-Drill	230	AFM90-TP..	Fresado Frontal / Surfaçage	Face Milling	342
				AFM90-VC2205.. -H	Fresado Frontal / Surfaçage	Face Milling	343
				AFM90-WN..	Fresado Frontal / Surfaçage	Face Milling	344
				AFM90-WNGO.. -H	Fresado Frontal / Surfaçage	Face Milling	343
				AFM90-XN..	Fresado Frontal / Surfaçage	Face Milling	345

CÓDIGO CODE / CODE	DESCRIPCIÓN / LA DESCRIPTION	DESCRIPTION	PN.
AFM90-XO..	Fresado Frontal / Surfaçage	Face Milling	345
AFMR(C)-RD..	Fresas Frontales y de Copia Visage et Copie End Mills	Face and Copy End Mills	348
AFMR-QP..	Fresas Frontales y de Copia Visage et Copie End Mills	Face and Copy End Mills	350
AFMR-RC..	Fresas Frontales y de Copia Visage et Copie End Mills	Face and Copy End Mills	347
AFMR-RP..	Fresas Frontales y de Copia Visage et Copie End Mills	Face and Copy End Mills	349
AFMR-RY..	Fresas Frontales y de Copia Visage et Copie End Mills	Face and Copy End Mills	350
AHFM(C)-JD..	Herramientas de Fresado de Alto Avance Outils de Fraisage à Grande Avance	High Feed Milling Tools	357
AHFM(C)-SD..	Fresas de Alto Avance Fraises à Grande Avance	High Feed End Mills	280
AHFM(C)-SD..	Herramientas de Fresado de Alto Avance Outils de Fraisage à Grande Avance	High Feed Milling Tools	358
AHFM(C)-SD..	Fresado Modulare de Alto Avance Fraises Modulaires à Grande Avance	Modular High Feed End Mills	300
AHFM(C)-WD..	Fresas de Alto Avance Fraises à Grande Avance	High Feed End Mills	283-284
AHFM(C)-WD..	Herramientas de Fresado de Alto Avance Outils de Fraisage à Grande Avance	High Feed Milling Tools	360
AHFM(L)-WN..	Herramientas de Fresado de Alto Avance Outils de Fraisage à Grande Avance	High Feed Milling Tools	361
AHFM-BL..	Fresas de Alto Avance Fraises à Grande Avance	High Feed End Mills	276
AHFM-BL..	Herramientas de Fresado de Alto Avance Outils de Fraisage à Grande Avance	High Feed Milling Tools	354
AHFM-BL..	Fresado Modulare de Alto Avance Fraises Modulaires à Grande Avance	Modular High Feed End Mills	295
AHFM-BN..	Fresas de Alto Avance Fraises à Grande Avance	High Feed End Mills	274
AHFMC-JD..	Fresas de Alto Avance Fraises à Grande Avance	High Feed End Mills	278
AHFMC-JD..	Fresado Modulare de Alto Avance Fraises Modulaires à Grande Avance	Modular High Feed End Mills	299
AHFMC-WD..	Fresado Modulare de Alto Avance Fraises Modulaires à Grande Avance	Modular High Feed End Mills	302-303
AHFM-ED..	Fresado Modulare de Alto Avance Fraises Modulaires à Grande Avance	Modular High Feed End Mills	296
AHFM-EN..	Fresas de Alto Avance Fraises à Grande Avance	High Feed End Mills	277
AHFM-EN..	Herramientas de Fresado de Alto Avance Outils de Fraisage à Grande Avance	High Feed Milling Tools	355
AHFM-EN..	Fresado Modulare de Alto Avance Fraises Modulaires à Grande Avance	Modular High Feed End Mills	297
AHFM-EO..	Fresas de Alto Avance Fraises à Grande Avance	High Feed End Mills	275
AHFM-EP..	Fresas de Alto Avance Fraises à Grande Avance	High Feed End Mills	275
AHFM-EP..	Herramientas de Fresado de Alto Avance Outils de Fraisage à Grande Avance	High Feed Milling Tools	355
AHFM-EP..	Fresado Modulare de Alto Avance Fraises Modulaires à Grande Avance	Modular High Feed End Mills	296
AHFM-JD..	Herramientas de Fresado de Alto Avance Outils de Fraisage à Grande Avance	High Feed Milling Tools	357
AHFM-JD..	Fresado Modulare de Alto Avance Fraises Modulaires à Grande Avance	Modular High Feed End Mills	299
AHFM-LN..	Fresas de Alto Avance Fraises à Grande Avance	High Feed End Mills	278
AHFM-LN..	Fresado Modulare de Alto Avance Fraises Modulaires à Grande Avance	Modular High Feed End Mills	298

CÓDIGO CODE / CODE	DESCRIPCIÓN / LA DESCRIPTION	DESCRIPTION	PN.
AHFM-LN0303.. -H	Fresas de Alto Avance Fraises à Grande Avance	High Feed End Mills	278
AHFM-LN0303.. -H	Fresas Modulares de Alto Avance (Tipo Tornillo) Fraises en Bout Modulaires (Type à Vis)	Modular (Screw Type) Highfeed End Mills	298
AHFM-LN0303.. -H	Herramientas de Fresado de Alto Avance Outils de Fraisage à Grande Avance	High Feed Milling Tools	356
AHFM-LO..	Fresas de Alto Avance Fraises à Grande Avance	High Feed End Mills	279
AHFM-LO..	Herramientas de Fresado de Alto Avance Outils de Fraisage à Grande Avance	High Feed Milling Tools	356
AHFM-LO..	Fresado Modulare de Alto Avance Fraises Modulaires à Grande Avance	Modular High Feed End Mills	298
AHFM-LP..	Fresas de Alto Avance Fraises à Grande Avance	High Feed End Mills	280
AHFM-SO..	Fresas de Alto Avance Fraises à Grande Avance	High Feed End Mills	281
AHFM-SO..	Herramientas de Fresado de Alto Avance Outils de Fraisage à Grande Avance	High Feed Milling Tools	359
AHFM-SO..	Fresado Modulare de Alto Avance Fraises Modulaires à Grande Avance	Modular High Feed End Mills	300-301
AHFM-SP..	Fresas de Alto Avance Fraises à Grande Avance	High Feed End Mills	281
AHFM-SP..	Herramientas de Fresado de Alto Avance Outils de Fraisage à Grande Avance	High Feed Milling Tools	359
AHFM-SP..	Fresado Modulare de Alto Avance Fraises Modulaires à Grande Avance	Modular High Feed End Mills	302
AHFM-WN..	Fresas de Alto Avance Fraises à Grande Avance	High Feed End Mills	284
AHFM-WN..	Fresado Modulare de Alto Avance Fraises Modulaires à Grande Avance	Modular High Feed End Mills	303
AHFM-WO..	Fresas de Alto Avance Fraises à Grande Avance	High Feed End Mills	285
AHFM-YO..	Fresas de Alto Avance Fraises à Grande Avance	High Feed End Mills	283
AHFM-YP..	Fresas de Alto Avance Fraises à Grande Avance	High Feed End Mills	282
AHFM-YP..	Fresado Modulare de Alto Avance Fraises Modulaires à Grande Avance	Modular High Feed End Mills	301
AHM ..	Herramientas de Fresado de Bisel Helicoidal Outils Helix Chanfrein Fraisage	Helix Chamfer Milling Tools	244
AHM90-AP..	Fresado de Punto en Helixe Fraise Hélicoïdale	Helix End Mills	310
AHM90-AP1204.. -H	Fresado de Punto en Helixe Fraise Hélicoïdale	Helix End Mills	310
AIKT-123-R/L ..	Portaherramientas de Ranurado Interno Porte-outil Interieur Rainurage	Internal Grooving Tool Holders	190
AIKT-154.91-R/L ..	Portaherramientas de Ranurado Interno Porte-outil Interieur Rainurage	Internal Grooving Tool Holders	190
AIKT-GP-R/L ..	Portaherramientas de Ranurado Interno Porte-outil Interieur Rainurage	Internal Grooving Tool Holders	194
AIKT-HK-R/L ..	Portaherramientas de Ranurado Interno Porte-outil Interieur Rainurage	Internal Grooving Tool Holders	189
AIKT-H-R/L ..	Portaherramientas de Ranurado Interno Porte-outil Interieur Rainurage	Internal Grooving Tool Holders	188
AIKT-HS223-R/L ..	Portaherramientas de Ranurado Interno Porte-outil Interieur Rainurage	Internal Grooving Tool Holders	189
AIKT-IGE-R/L ..	Portaherramientas de Ranurado Interno Porte-outil Interieur Rainurage	Internal Grooving Tool Holders	192
AIKT-IGI-R/L ..	Portaherramientas de Ranurado Interno Porte-outil Interieur Rainurage	Internal Grooving Tool Holders	192
AIKT-IG-R/L ..	Portaherramientas de Ranurado Interno Porte-outil Interieur Rainurage	Internal Grooving Tool Holders	193

CÓDIGO CODE / CODE	DESCRIPCIÓN / LA DESCRIPTION	DESCRIPTION	P.N.	CÓDIGO CODE / CODE	DESCRIPCIÓN / LA DESCRIPTION	DESCRIPTION	P.N.
AIKT-I-R/L ..	Portaherramientas de Ranurado Interno Porte-outil Interieur Rainurage	Internal Grooving Tool Holders	193	ATSMR-RD..	Fresado de Ranura en T / Rainurage en T	T Slot Milling	363
AIKT-ITG-R/L ..	Portaherramientas de Ranurado Interno Porte-outil Interieur Rainurage	Internal Grooving Tool Holders	194	ATTB ..	Herramientas Antivibración Outil Anti Vibratoire	Anti Vibration Tool	131
AIKT-KG-R/L ..	Portaherramientas de Ranurado Interno Porte-outil Interieur Rainurage	Internal Grooving Tool Holders	188	ATTC ..	Herramientas Antivibración Outil Anti Vibratoire	Anti Vibration Tool	134
AIKT-KM-R/L ..	Portaherramientas de Ranurado Interno Porte-outil Interieur Rainurage	Internal Grooving Tool Holders	189	ATTC- .. SCLCR/L ..	Herramientas Antivibración Outil Anti Vibratoire	Anti Vibration Tool	132
AIKT-K-R/L ..	Portaherramientas de Ranurado Interno Porte-outil Interieur Rainurage	Internal Grooving Tool Holders	187	ATTC- .. SDUCR/L ..	Herramientas Antivibración Outil Anti Vibratoire	Anti Vibration Tool	132
AIKT-MB..	Mini Herramienta de Ranurado Mini Porte-Outil de Rainurage Externe	Mini Grooving Tool Holder	197	ATTC- .. SVUCR/L ..	Herramientas Antivibración Outil Anti Vibratoire	Anti Vibration Tool	133
AIKT-QC.-R/L ..	Portaherramientas de Ranurado Interno Porte-outil Interieur Rainurage	Internal Grooving Tool Holders	195	ATTC- .. TCLNR/L ..	Herramientas Antivibración Outil Anti Vibratoire	Anti Vibration Tool	134
AIKT-RD-R/L ..	Portaherramientas de Ranurado Interno Porte-outil Interieur Rainurage	Internal Grooving Tool Holders	191	ATTC- .. TDUNR/L ..	Herramientas Antivibración Outil Anti Vibratoire	Anti Vibration Tool	133
AIKT-SGC-R ..	Portaherramientas de Ranurado Interno Porte-outil Interieur Rainurage	Internal Grooving Tool Holders	196	ATUM .. xD2 KDR ..	Taladro en U / U-Drill	U-Drill	221
AIKT-TD-R/L ..	Portaherramientas de Ranurado Interno Porte-outil Interieur Rainurage	Internal Grooving Tool Holders	191	ATUM .. xD2 SP ..	Taladro en U / U-Drill	U-Drill	209-210
AIKT-TG-R/L ..	Portaherramientas de Ranurado Interno Porte-outil Interieur Rainurage	Internal Grooving Tool Holders	195	ATUM .. xD2 SPGT ..	Taladro en U / U-Drill	U-Drill	215
AIKT-ZCC2-R/L ..	Portaherramientas de Ranurado Interno Porte-outil Interieur Rainurage	Internal Grooving Tool Holders	196	ATUM .. xD2 WCM ..	Taladro en U / U-Drill	U-Drill	202-203
AKCR ..	Cartucho de Cabezas de Mandrillado Áspero Ajustable Cartouches Têtes D'alésage Réglables Bruts	Adjustable Rough Boring Heads Cartridges	239	ATUM .. xD3 KDR ..	Taladro en U / U-Drill	U-Drill	222
AKL-123 ..	Cuchillas / Lames	Blades	182	ATUM .. xD3 SO ..	Taladro en U / U-Drill	U-Drill	219
AKL-I ..	Cuchillas / Lames	Blades	181	ATUM .. xD3 SP ..	Taladro en U / U-Drill	U-Drill	211-212
AKL-SGC ..	Cuchillas / Lames	Blades	180	ATUM .. xD3 SPGT ..	Taladro en U / U-Drill	U-Drill	216-217
AKL-TD ..	Cuchillas / Lames	Blades	181	ATUM .. xD3 WCM ..	Taladro en U / U-Drill	U-Drill	204-205
AKSR ..	Cartucho de Cabezas de Mandrillado Áspero Ajustable Cartouches Têtes D'alésage Réglables Bruts	Adjustable Rough Boring Heads Cartridges	239	ATUM .. xD4 KDR ..	Taladro en U / U-Drill	U-Drill	221
ALBU ..	Bloques Para Cuchillas Blocs Pour Lames	Blocks For Blades	182	ATUM .. xD4 SO ..	Taladro en U / U-Drill	U-Drill	220
ALKT-ZCC2-R/L ..	Portaherramientas de Ranurado Externo Frontal Porte Outil Face Rainurage Exterieur	Face External Grooving Tool Holders	180	ATUM .. xD4 SP ..	Taladro en U / U-Drill	U-Drill	213
APMR-BNM..	Fresas de Punta Esferica Fraise à Bout Sphérique	Ball Nose End Mills	304	ATUM .. xD4 SPGT ..	Taladro en U / U-Drill	U-Drill	218
APMR-BNM..	Fresas de Punta Esferica Modular Fraise à Bout Sphérique Modulaire	Modular Ball Nose End Mills	306	ATUM .. xD4 WCM ..	Taladro en U / U-Drill	U-Drill	206-207
APMR-P32..	Fresas de Punta Esferica Fraise à Bout Sphérique	Ball Nose End Mills	305	ATUM .. xD5 SP ..	Taladro en U / U-Drill	U-Drill	214
APMR-P32..	Fresas de Punta Esferica Modular Fraise à Bout Sphérique Modulaire	Modular Ball Nose End Mills	306	ATUM .. xD5 WCM ..	Taladro en U / U-Drill	U-Drill	208
APMR-RO..	Fresas de Punta Esferica Fraise à Bout Sphérique	Ball Nose End Mills	304	ATUM xD2 SOMT ..	Taladro en U / U-Drill	U-Drill	223
APMR-SWB..	Fresas de Punta Esferica Modular Fraise à Bout Sphérique Modulaire	Modular Ball Nose End Mills	307	ATUM xD3 880 ..	Taladro en U / U-Drill	U-Drill	227
APMR-XP..	Fresas de Punta Esferica Fraise à Bout Sphérique	Ball Nose End Mills	305	ATUM xD3 SOMT ..	Taladro en U / U-Drill	U-Drill	224
APMR-XP..	Fresas de Punta Esferica Modular Fraise à Bout Sphérique Modulaire	Modular Ball Nose End Mills	307	ATUM xD4 SOMT ..	Taladro en U / U-Drill	U-Drill	225
ASDM-CC..	Fresas de Disco / Disque de Fraisage	Disc Milling	365	ATUM xD5 SOMT ..	Taladro en U / U-Drill	U-Drill	226
ASDM-SPGT..	Fresas de Disco / Disque de Fraisage	Disc Milling	364	ATW-..	Portaherramientas Giratorios Porte-outils Tourbillonnant	Whirling Tool Holders	27
ASTB-..	Herramientas Suizas de Cambio Fácil Outils Swiss Easy Change	Swiss Easy Change Tools	87	AVTT..	Portaherramientas de Atornillar Porte-outil Vissé	Screwed Tool Holders	308
ATM..	Herramientas de Fresado de Roscas Outils du Fraisage	Thread Milling Tools	308	B11..	Insertos de Asiento de Válvula Plaquettes de Siège de Soupape	Valve Seat Machining Inserts	24-25
ATM60..	Herramientas de Fresado de Roscas Outils du Fraisage	Thread Milling Tools	309	B41.. - B42..	Insertos de Brochado Plaquettes de Brochage	Broaching Inserts	18-19-20
ATSM90-CC..	Fresado de Ranura en T / Rainurage en T	T Slot Milling	362	CCLNR/L ..	Portaherramientas Externos / Porte-outil Exterieur	External Tool Holders	65
ATSM90-SP..	Fresado de Ranura en T / Rainurage en T	T Slot Milling	363	CDJNR/L ..	Portaherramientas Externos / Porte-outil Exterieur	External Tool Holders	65
				CDNNN ..	Portaherramientas Externos / Porte-outil Exterieur	External Tool Holders	66
				CKJNR/L ..	Portaherramientas Externos / Porte-outil Exterieur	External Tool Holders	64
				CKUNR/L ..	Portaherramientas Externos / Porte-outil Exterieur	External Tool Holders	98
				CRDCN ..	Portaherramientas Externos / Porte-outil Exterieur	External Tool Holders	66
				CRDCR/L ..	Portaherramientas Externos / Porte-outil Exterieur	External Tool Holders	67
				CSDNN ..	Portaherramientas Externos / Porte-outil Exterieur	External Tool Holders	67
				CSKNR/L ..	Portaherramientas Externos / Porte-outil Exterieur	External Tool Holders	68
				CSRNR/L ..	Portaherramientas Externos / Porte-outil Exterieur	External Tool Holders	68
				CSSNR/L ..	Portaherramientas Externos / Porte-outil Exterieur	External Tool Holders	69
				CTJNR/L ..	Portaherramientas Externos / Porte-outil Exterieur	External Tool Holders	69

CÓDIGO CODE / CODE	DESCRIPCIÓN / LA DESCRIPTION	DESCRIPTION	P.N.
E/SCLCR/L ..	Barras de Mandrillar Set Ensemble de Barres D'alésage	Boring Bars Set	127
E/SDUCR/L ..	Barras de Mandrillar Set Ensemble de Barres D'alésage	Boring Bars Set	128
E/STFCR/L ..	Barras de Mandrillar / Barres D'alésage	Boring Bars	126
E/STUPR/L ..	Barras de Mandrillar / Barres D'alésage	Boring Bars	126
MCLNR/L ..	Portaherramientas Internos / Porte-outils Interieur	Internal Tool Holders	100
MDUNR/L ..	Portaherramientas Internos / Porte-outils Interieur	Internal Tool Holders	100
MTENN ..	Portaherramientas Externos / Porte-outil Exterieur	External Tool Holders	49
MTFNR/L ..	Portaherramientas Internos / Porte-outils Interieur	Internal Tool Holders	101
MTJNR/L ..	Portaherramientas Externos / Porte-outil Exterieur	External Tool Holders	49
MT-NR/L ..	Portaherramientas Internos / Porte-outils Interieur	Internal Tool Holders	101
MTQNR/L ..	Portaherramientas Internos / Porte-outils Interieur	Internal Tool Holders	102
MTUNR/L ..	Portaherramientas Internos / Porte-outils Interieur	Internal Tool Holders	102
MWLNLR/L ..	Portaherramientas Externos / Porte-outil Exterieur	External Tool Holders	50
MWLNLR/L ..	Portaherramientas Internos / Porte-outils Interieur	Internal Tool Holders	103
MWMNN ..	Portaherramientas Externos / Porte-outil Exterieur	External Tool Holders	50
PCBNR/L ..	Portaherramientas Externos / Porte-outil Exterieur	External Tool Holders	52
PCLNR/L ..	Portaherramientas Externos / Porte-outil Exterieur	External Tool Holders	52
PCLNR/L ..	Portaherramientas Internos / Porte-outils Interieur	Internal Tool Holders	105
PCLNR/L...-H	Portaherramientas de Tornado Externo con Agujero Refrigerante Porte-outils de Tournage Exterieurs Avec Trou d'arrosage	External Turning Tool Holders With Coolant Hole	60
PCMNN ..	Portaherramientas Externos / Porte-outil Exterieur	External Tool Holders	53
PDJNR/L ..	Portaherramientas Externos / Porte-outil Exterieur	External Tool Holders	53
PDJNR/L ..-H	Portaherramientas de Tornado Externo con Agujero Refrigerante Porte-outils de Tournage Exterieurs Avec Trou d'arrosage	External Turning Tool Holders With Coolant Hole	60
PDNNN ..	Portaherramientas Externos / Porte-outil Exterieur	External Tool Holders	54
PDNNN-H	Portaherramientas de Tornado Externo con Agujero Refrigerante Porte-outils de Tournage Exterieurs Avec Trou d'arrosage	External Turning Tool Holders With Coolant Hole	61
PDQNR/L ..	Portaherramientas Internos / Porte-outils Interieur	Internal Tool Holders	106
PDUNR/L ..	Portaherramientas Internos / Porte-outils Interieur	Internal Tool Holders	107
PDXNR/L ..	Portaherramientas Internos / Porte-outils Interieur	Internal Tool Holders	106
PSBNR/L ..	Portaherramientas Externos / Porte-outil Exterieur	External Tool Holders	54
PSDNN ..	Cartucho / Cartouche	Cartridge	146
PSDNN ..	Portaherramientas Externos / Porte-outil Exterieur	External Tool Holders	55
PSKNR/L ..	Cartucho / Cartouche	Cartridge	144
PSKNR/L ..	Portaherramientas Externos / Porte-outil Exterieur	External Tool Holders	55
PSKNR/L ..	Portaherramientas Internos / Porte-outils Interieur	Internal Tool Holders	108
PSRNR/L ..	Cartucho / Cartouche	Cartridge	145
PSSNR/L ..	Portaherramientas Externos / Porte-outil Exterieur	External Tool Holders	56
PTFNR/L ..	Cartucho / Cartouche	Cartridge	145
PTFNR/L ..	Portaherramientas Externos / Porte-outil Exterieur	External Tool Holders	56
PTGNR/L ..	Portaherramientas Externos / Porte-outil Exterieur	External Tool Holders	57
PTJNR/L ..	Portaherramientas Externos / Porte-outil Exterieur	External Tool Holders	57
PTTNR/L ..	Portaherramientas Externos / Porte-outil Exterieur	External Tool Holders	58
PTUNR/L ..	Portaherramientas Internos / Porte-outils Interieur	Internal Tool Holders	109
PWLNLR/L ..	Portaherramientas Externos / Porte-outil Exterieur	External Tool Holders	58
PWLNLR/L ..	Portaherramientas Internos / Porte-outils Interieur	Internal Tool Holders	110
PWLNLR/L ..-H	Portaherramientas de Tornado Externo con Agujero Refrigerante Porte-outils de Tournage Exterieurs Avec Trou d'arrosage	External Turning Tool Holders With Coolant Hole	61
S/SCLCR/L ..	Barras de Mandrillar Set Ensemble de Barres D'alésage	Boring Bars Set	127

CÓDIGO CODE / CODE	DESCRIPCIÓN / LA DESCRIPTION	DESCRIPTION	P.N.
S/SDUCR/L ..	Barras de Mandrillar Set Ensemble de Barres D'alésage	Boring Bars Set	128
SCACR/L ..	Cartucho de Reacondicionamiento del Motor Moteur Refonte Cartouche	Engine Overhaul Cartridge	139
SCACR/L ..	Portaherramientas Externos / Porte-outil Exterieur	External Tool Holders	71
SCACR/L ..-S	Portaherramientas Externos Tipo Suizo Porte-outil Exterieur Suisse Type	External Tool Holders Swiss Type	83
SCFCR/L ..	Repuestos de Cartucho Pièces de Rechange de la Cartouche	Cartridge's Spare Parts	146
SCFCR/L ..	Cartucho / Cartouche	Cartridge	141
SCFCR/L ..	Portaherramientas Internos / Porte-outils Interieur	Internal Tool Holders	113
SCLCR/L ..	Barras de Mandrillar con Mango de Carburo Barres D'alésage Avec Shank Carbure	Boring Bars With Carbide Shank	125
SCLCR/L ..	Portaherramientas Externos / Porte-outil Exterieur	External Tool Holders	71
SCLCR/L ..	Portaherramientas Internos / Porte-outils Interieur	Internal Tool Holders	112
SCLCR/L ..-S	Portaherramientas Externos Tipo Suizo Porte-outil Exterieur Suisse Type	External Tool Holders Swiss Type	84
SCMCN ..	Cartucho de Reacondicionamiento del Motor Moteur Refonte Cartouche	Engine Overhaul Cartridge	140
SCMCN ..	Portaherramientas Internos / Porte-outils Interieur	External Tool Holders	72
SCSCR/L ..	Repuestos de Cartucho Pièces de Rechange de la Cartouche	Cartridge's Spare Parts	146
SCSCR/L ..	Cartucho / Cartouche	Cartridge	142
SDACR/L ..-S	Portaherramientas Externos Tipo Suizo Porte-outil Exterieur Suisse Type	External Tool Holders Swiss Type	84
SD-CR/L ..	Portaherramientas Internos / Porte-outils Interieur	Internal Tool Holders	113
SDHCR/L ..	Portaherramientas Externos / Porte-outil Exterieur	External Tool Holders	72
SDJCR/L ..	Portaherramientas Externos / Porte-outil Exterieur	External Tool Holders	73
SDJCR/L ..-S	Portaherramientas Externos Tipo Suizo Porte-outil Exterieur Suisse Type	External Tool Holders Swiss Type	85
SDJCR/L ..	Herramientas Suizas de Cambio Fácil Outils Swiss Easy Change	Swiss Easy Change Tools	88
SDNCN ..	Portaherramientas Externos / Porte-outil Exterieur	External Tool Holders	73
SDPCR/L ..	Portaherramientas Internos / Porte-outils Interieur	Internal Tool Holders	114
SDQCR/L ..	Portaherramientas Internos / Porte-outils Interieur	Internal Tool Holders	114
SDUCR/L ..	Barras de Mandrillar con Mango de Carburo Barres D'alésage Avec Shank Carbure	Boring Bars With Carbide Shank	125
SDUCR/L ..	Portaherramientas Internos / Porte-outils Interieur	Internal Tool Holders	115
SDXCR/L ..	Portaherramientas Internos / Porte-outils Interieur	Internal Tool Holders	116
SER/L ..	Portaherramientas de Roscado Externo Porte-outils de Filetage Exterieurs	External Threading Tool Holders	150
SER/L ..	Herramientas Suizas de Cambio Fácil Outils Swiss Easy Change	Swiss Easy Change Tools	89
SIR/L ..	Portaherramientas de Roscado Interno Porte-outils de Filetage Interieur	Internal Threading Tool Holders	151
SRDCN ..	Portaherramientas Externos / Porte-outil Exterieur	External Tool Holders	74
SRDCR/L ..	Portaherramientas Externos / Porte-outil Exterieur	External Tool Holders	75
SRGCR/L ..	Portaherramientas Externos / Porte-outil Exterieur	External Tool Holders	75
SRGCR/L ..	Portaherramientas Externos / Porte-outil Exterieur	External Tool Holders	117
SRHCR/L ..	Portaherramientas Externos / Porte-outil Exterieur	External Tool Holders	76
SRSCN..	Cartucho de Reacondicionamiento del Motor Moteur Refonte Cartouche	Engine Overhaul Cartridge	140
SRXCR/L ..	Portaherramientas Internos / Porte-outils Interieur	External Tool Holders	76
SSDCN ..	Portaherramientas Internos / Porte-outils Interieur	External Tool Holders	77
SSKCR/L ..	Cartucho / Cartouche	Cartridge	142
SSSCR/L ..	Portaherramientas Externos / Porte-outil Exterieur	External Tool Holders	77
SSSCR/L ..	Portaherramientas Internos / Porte-outils Interieur	Internal Tool Holders	117

CÓDIGO CODE / CODE	DESCRIPCIÓN / LA DESCRIPTION	DESCRIPTION	P.N.
STCCN ..	Portaherramientas Externos / Porte-outil Exterieur	External Tool Holders	79
ST-CR/L ..	Portaherramientas Internos / Porte-outils Interieur	Internal Tool Holders	118
STFCR/L	Repuestos de Cartucho Pièces de Rechange de la Cartouche	Cartridge's Spare Parts	146
STFCR/L ..	Cartucho / Cartouche	Cartridge	143
STFCR/L ..	Portaherramientas Externos / Porte-outil Exterieur	External Tool Holders	78
STFCR/L ..	Portaherramientas Internos / Porte-outils Interieur	Internal Tool Holders	118
STGCR/L ..	Portaherramientas Externos / Porte-outil Exterieur	External Tool Holders	78
STGCR/L ..-S	Portaherramientas Externos Tipo Suizo Porte-outil Exterieur Suisse Type	External Tool Holders Swiss Type	85
STJCR/L ..	Portaherramientas Externos / Porte-outil Exterieur	External Tool Holders	79
STSCR/L	Repuestos de Cartucho Pièces de Rechange de la Cartouche	Cartridge's Spare Parts	146
STSCR/L ..	Cartucho / Cartouche	Cartridge	143
STTCR/L	Repuestos de Cartucho Pièces de Rechange de la Cartouche	Cartridge's Spare Parts	146
STTCR/L ..	Cartucho / Cartouche	Cartridge	144
STUCR/L ..	Portaherramientas Externos / Porte-outil Exterieur	External Tool Holders	80
STUCR/L ..	Portaherramientas Internos / Porte-outils Interieur	Internal Tool Holders	119
STUPR/L ..	Portaherramientas Internos / Porte-outils Interieur	Internal Tool Holders	120
STXCR/L ..	Cartucho de Reacondicionamiento del Motor Moteur Refonte Cartouche	Engine Overhaul Cartridge	141
SVACR/L ..-S	Portaherramientas Externos Tipo Suizo Porte-outil Exterieur Suisse Type	External Tool Holders Swiss Type	86
SVHBR/L ..	Portaherramientas Externos / Porte-outil Exterieur	External Tool Holders	80
SVHCR/L ..	Portaherramientas Externos / Porte-outil Exterieur	External Tool Holders	81
SVJBR/L ..	Portaherramientas Externos / Porte-outil Exterieur	External Tool Holders	81
SVJBR/L ..	Portaherramientas Internos / Porte-outils Interieur	Internal Tool Holders	120
SVJBR/L ..-S	Portaherramientas Externos Tipo Suizo Porte-outil Exterieur Suisse Type	External Tool Holders Swiss Type	86
SVJCR/L	Herramientas Suizas de Cambio Fácil Outils Swiss Easy Change	Swiss Easy Change Tools	88
SVJCR/L ..	Portaherramientas Externos / Porte-outil Exterieur	External Tool Holders	82
SVJCR/L ..	Portaherramientas Internos / Porte-outils Interieur	Internal Tool Holders	123
SVJCR/L ..-S	Portaherramientas Externos Tipo Suizo Porte-outil Exterieur Suisse Type	External Tool Holders Swiss Type	87
SVQBR/L ..	Portaherramientas Internos / Porte-outils Interieur	Internal Tool Holders	121
SVQCR/L ..	Portaherramientas Internos / Porte-outils Interieur	Internal Tool Holders	121
SVUBR/L ..	Portaherramientas Internos / Porte-outils Interieur	Internal Tool Holders	122
SVUCR/L ..	Portaherramientas Internos / Porte-outils Interieur	Internal Tool Holders	122
SVVBN ..	Portaherramientas Externos / Porte-outil Exterieur	External Tool Holders	82
SVVCN ..	Portaherramientas Externos / Porte-outil Exterieur	External Tool Holders	83
SVXBR/L ..	Portaherramientas Internos / Porte-outils Interieur	Internal Tool Holders	123
SWLCR ..	Portaherramientas Internos / Porte-outils Interieur	Internal Tool Holders	124
SWUBR ..	Portaherramientas Internos / Porte-outils Interieur	Internal Tool Holders	124
T09..	Insertos Giratorios Plaquettes de Tourbillonnage	Whirling Inserts	28-29
T12.10	Insertos de Ranurado Poly-V Plaquettes Poly-V Rainurage	Poly-V Grooving Inserts	12
T20	Insertos de Ranurado de Relieves de Esquina Plaquettes de Rainurage des Reliefs D'angle	Corner Reliefs Grooving Inserts	16
TCBNR/L ..	Portaherramientas Externos / Porte-outil Exterieur	External Tool Holders	35
TCKNR/L ..	Portaherramientas Externos / Porte-outil Exterieur	External Tool Holders	35
TCLNR/L ..	Portaherramientas Externos / Porte-outil Exterieur	External Tool Holders	36
TCLNR/L ..	Portaherramientas Internos / Porte-outils Interieur	Internal Tool Holders	94

CÓDIGO CODE / CODE	DESCRIPCIÓN / LA DESCRIPTION	DESCRIPTION	P.N.
TCLNR/L .. -H	Portaherramientas de Torno con Agujero Refrigerante Porte-outils de Tournage Exterieurs Avec Trou d'arrosage	External Turning Tool Holders With Coolant Hole	45
TCMNN ..	Portaherramientas Externos / Porte-outil Exterieur	External Tool Holders	36
TCZNN ..	Portaherramientas Externos / Porte-outil Exterieur	External Tool Holders	37
TDHNR/L ..	Portaherramientas Externos / Porte-outil Exterieur	External Tool Holders	37
TDJNR/L ..	Portaherramientas Externos / Porte-outil Exterieur	External Tool Holders	38
TDJNR/L .. -H	Portaherramientas de Torno con Agujero Refrigerante Porte-outils de Tournage Exterieurs Avec Trou d'arrosage	External Turning Tool Holders With Coolant Hole	45
TDNNN ..	Portaherramientas Externos / Porte-outil Exterieur	External Tool Holders	38
TDNNN-H	Portaherramientas de Torno con Agujero Refrigerante Porte-outils de Tournage Exterieurs Avec Trou d'arrosage	External Turning Tool Holders With Coolant Hole	46
TD-NR/L ..	Portaherramientas Internos / Porte-outils Interieur	Internal Tool Holders	94
TDQNR/L ..	Portaherramientas Internos / Porte-outils Interieur	Internal Tool Holders	95
TDUNR/L ..	Portaherramientas Internos / Porte-outils Interieur	Internal Tool Holders	95
TER/L ..	Portaherramientas de Roscado Externo Porte-outils de Filetage Exterieurs	External Threading Tool Holders	152
TER/L ..	Herramientas Suizas de Cambio Fácil Outils Swiss Easy Changei	Swiss Easy Change Tools	89
TIR/L ..	Portaherramientas de Roscado Interno Porte-outils de Filetage Interieur	Internal Threading Tool Holders	153
TSDNN ..	Portaherramientas Externos / Porte-outil Exterieur	External Tool Holders	39
TSKNR/L ..	Portaherramientas Externos / Porte-outil Exterieur	External Tool Holders	39
TSKNR/L ..	Portaherramientas Internos / Porte-outils Interieur	Internal Tool Holders	96
TSSNR/L ..	Portaherramientas Externos / Porte-outil Exterieur	External Tool Holders	40
TTENN ..	Portaherramientas Externos / Porte-outil Exterieur	External Tool Holders	40
TTGNR/L ..	Portaherramientas Externos / Porte-outil Exterieur	External Tool Holders	41
TTJNR/L ..	Portaherramientas Externos / Porte-outil Exterieur	External Tool Holders	41
TT-NR/L ..	Portaherramientas Internos / Porte-outils Interieur	Internal Tool Holders	96
TTUNR/L ..	Portaherramientas Internos / Porte-outils Interieur	Internal Tool Holders	97
TVHNR/L ..	Portaherramientas Externos / Porte-outil Exterieur	External Tool Holders	42
TVJNR/L ..	Portaherramientas Externos / Porte-outil Exterieur	External Tool Holders	42
TVUNR/L ..	Portaherramientas Internos / Porte-outils Interieur	Internal Tool Holders	97
TVVNN ..	Portaherramientas Externos / Porte-outil Exterieur	External Tool Holders	43
TWLNR/L ..	Portaherramientas Externos / Porte-outil Exterieur	External Tool Holders	43
TWLNR/L ..	Portaherramientas Internos / Porte-outils Interieur	Internal Tool Holders	98
TWLNR/L .. -H	Portaherramientas de Torno con Agujero Refrigerante Porte-outils de Tournage Exterieurs Avec Trou d'arrosage	External Turning Tool Holders With Coolant Hole	46
VST-B11..	Portaherramientas de Asiento de Válvula Porte-outils de Siège de Soupape	Valve Seat Machining Tool Holders	23-24

konusulan
the spoken kalite...
quality...



konusulan
the spoken **kalite...**
quality...





